

BS ISO 18746:2016



BSI Standards Publication

Traditional Chinese medicine — Sterile intradermal acupuncture needles for single use

National foreword

This British Standard is the UK implementation of ISO 18746:2016.

The UK participation in its preparation was entrusted to Technical Committee CH/100, Healthcare and Medical Equipment.

A list of organizations represented on this committee can be obtained on request to its secretary.

This publication does not purport to include all the necessary provisions of a contract. Users are responsible for its correct application.

© The British Standards Institution 2016.
Published by BSI Standards Limited 2016

ISBN 978 0 580 82852 2

ICS 11.040.25

Compliance with a British Standard cannot confer immunity from legal obligations.

This British Standard was published under the authority of the Standards Policy and Strategy Committee on 31 August 2016.

Amendments/corrigenda issued since publication

Date	Text affected
------	---------------

INTERNATIONAL
STANDARD

BS ISO 18746:2016

ISO
18746

First edition
2016-08-15

**Traditional Chinese medicine —
Sterile intradermal acupuncture
needles for single use**

*Médecine traditionnelle chinoise — Aiguilles d'acupuncture
intradermiques stériles à usage unique*



Reference number
ISO 18746:2016(E)

© ISO 2016



COPYRIGHT PROTECTED DOCUMENT

© ISO 2016, Published in Switzerland

All rights reserved. Unless otherwise specified, no part of this publication may be reproduced or utilized otherwise in any form or by any means, electronic or mechanical, including photocopying, or posting on the internet or an intranet, without prior written permission. Permission can be requested from either ISO at the address below or ISO's member body in the country of the requester.

ISO copyright office
Ch. de Blandonnet 8 • CP 401
CH-1214 Vernier, Geneva, Switzerland
Tel. +41 22 749 01 11
Fax +41 22 749 09 47
copyright@iso.org
www.iso.org

Contents

Page

Foreword	iv
Introduction	v
1 Scope	1
2 Normative references	1
3 Terms and definitions	1
4 Structure and dimension of intradermal acupuncture needles	2
4.1 Size designation.....	2
4.2 Structure and dimension of intradermal granule type needle.....	3
4.2.1 Structure of intradermal granule type needle.....	3
4.2.2 Dimension of intradermal granule type needle.....	3
4.3 Structure and dimension of intradermal thumbtack type needle.....	4
4.3.1 Structure of intradermal thumbtack type needle.....	4
4.3.2 Dimension of intradermal thumbtack type needle.....	4
5 Materials	5
5.1 General.....	5
5.2 Body of intradermal acupuncture needle.....	5
6 Performance requirements	5
6.1 Appearance and cleanliness.....	5
6.2 Drawing strength.....	5
6.3 Hardness of the needle body.....	6
6.4 Intensity and puncture performance of the needle tip.....	6
6.5 Sterility.....	6
7 Packing and identification	6
7.1 Primary packaging.....	6
7.1.1 Packing method.....	6
7.1.2 Identification.....	6
7.2 Secondary packaging.....	7
7.2.1 Packing method.....	7
7.2.2 Identification.....	7
Bibliography	8

Foreword

ISO (the International Organization for Standardization) is a worldwide federation of national standards bodies (ISO member bodies). The work of preparing International Standards is normally carried out through ISO technical committees. Each member body interested in a subject for which a technical committee has been established has the right to be represented on that committee. International organizations, governmental and non-governmental, in liaison with ISO, also take part in the work. ISO collaborates closely with the International Electrotechnical Commission (IEC) on all matters of electrotechnical standardization.

The procedures used to develop this document and those intended for its further maintenance are described in the ISO/IEC Directives, Part 1. In particular the different approval criteria needed for the different types of ISO documents should be noted. This document was drafted in accordance with the editorial rules of the ISO/IEC Directives, Part 2 (see www.iso.org/directives).

Attention is drawn to the possibility that some of the elements of this document may be the subject of patent rights. ISO shall not be held responsible for identifying any or all such patent rights. Details of any patent rights identified during the development of the document will be in the Introduction and/or on the ISO list of patent declarations received (see www.iso.org/patents).

Any trade name used in this document is information given for the convenience of users and does not constitute an endorsement.

For an explanation on the meaning of ISO specific terms and expressions related to conformity assessment, as well as information about ISO's adherence to the World Trade Organization (WTO) principles in the Technical Barriers to Trade (TBT) see the following URL: www.iso.org/iso/foreword.html.

The committee responsible for this document is ISO/TC 249, *Traditional Chinese medicine*.

Introduction

As one of several different needling approaches, intradermal acupuncture needles are recognized as an effective treatment for various disorders. Intradermal acupuncture needles are easy to use and especially effective when relatively long-lasting stimulation to a needling site is needed. Therefore, safety and sanitation considerations of intradermal acupuncture needles should be more carefully reviewed as well as their compatibility to human body.

As a biomaterial, acupuncture needles can be corrosive and have potential to lose some of their mechanical characteristics. Furthermore, leachable substances can affect human tissue in any unintended, yet potentially harmful way. To address this problem, biomaterials should have no toxicity or produce any adverse effects, and should have appropriate mechanical characteristics such as tensile strength, elasticity, durability of abrasion and fatigue strength. In addition, the material should have a strong corrosion resistant ability.

This International Standard establishes an international standard for intradermal acupuncture needles. The characteristics of intradermal acupuncture needles include size, material, quality, tests, packing and identification through regulating marking methods. The standardization of the characteristics of intradermal acupuncture needles has potential to enhance the efficacy and improve the quality and safety of acupuncture treatments using intradermal acupuncture needles especially in regard to the biocompatibility for human body.

Traditional Chinese medicine — Sterile intradermal acupuncture needles for single use

1 Scope

This International Standard specifies the requirements of sterile intradermal acupuncture needle for single use as a medical device, including the following factors:

- a) size;
- b) material;
- c) quality;
- d) testing methods;
- e) packing;
- f) identification.

2 Normative references

The following documents, in whole or in part, are normatively referenced in this document and are indispensable for its application. For dated references, only the edition cited applies. For undated references, the latest edition of the referenced document (including any amendments) applies.

ISO 10993-1, *Biological evaluation of medical devices — Part 1: Evaluation and testing within a risk management process*

ISO 10993-7, *Biological evaluation of medical devices — Part 7: Ethylene oxide sterilization residuals*

ISO 15223-1, *Medical devices — Symbols to be used with medical device labels, labelling and information to be supplied — Part 1: General requirements*

ISO 17218:2014, *Sterile acupuncture needles for single use*

3 Terms and definitions

For the purposes of this document, the following terms and definitions apply.

3.1

intradermal acupuncture needles

small needling instrument for embedding in the skin

Note 1 to entry: There are two types of intradermal acupuncture needles. One is termed an intradermal thumbtack type needle and the other is intradermal granule type needle.

[SOURCE: WHO International Standard Terminologies on Traditional Medicine in the Western Pacific Region, 5.1.29, modified — Note 1 to entry has been added.]

3.2

intradermal granule type needle

intradermal acupuncture needle inserted obliquely or horizontally into subcutaneous tissue often across various sites on the human body

3.3

intra-dermal thumbtack type needle

intra-dermal acupuncture needle resembling a thumbtack

[SOURCE: WHO International Standard Terminologies on Traditional Medicine in the Western Pacific Region, 5.1.28]

3.4

body of the needle

part of the intra-dermal acupuncture needle that is inserted into the human body

[SOURCE: ISO 17218:2014, 3.1, modified]

3.5

handle of the needle

part of the intra-dermal acupuncture needle that is not inserted into the human body and is often used to manipulate the needle during insertion

[SOURCE: ISO 17218:2014, 3.2, modified]

3.6

tip of the needle

sharp apex at the end of the acupuncture needle body that is inserted into the human body

[SOURCE: ISO 17218:2014, 3.3]

3.7

primary package

sealed or closed packaging system that forms a microbial barrier, directly enclosing the acupuncture needle

[SOURCE: ISO 17218:2014, 3.9]

3.8

secondary package

package containing one or more primary packages for transportation and storage

[SOURCE: ISO 17218:2014, 3.10, modified]

4 Structure and dimension of intra-dermal acupuncture needles

4.1 Size designation

The size of the body of the needle shall be designated by the following:

- a) the nominal diameter of the body of the needle (or when no body of the needle, the maximum diameter of the tip of the needle), expressed in millimetres;
- b) the nominal length of the body of the needle, expressed in millimetres.

The size shall be referred to as “the designated metric size” and specified as a) × b).

EXAMPLE Ø 0,16 mm × 10 mm.

4.2 Structure and dimension of intradermal granule type needle

4.2.1 Structure of intradermal granule type needle

The intradermal granule type needle shall have the structure as shown in [Figure 1](#) and be composed of the body of the needle, the handle of the needle and the tape (in some cases). The type of needle handles are not limited to those shown in [Figure 1](#).

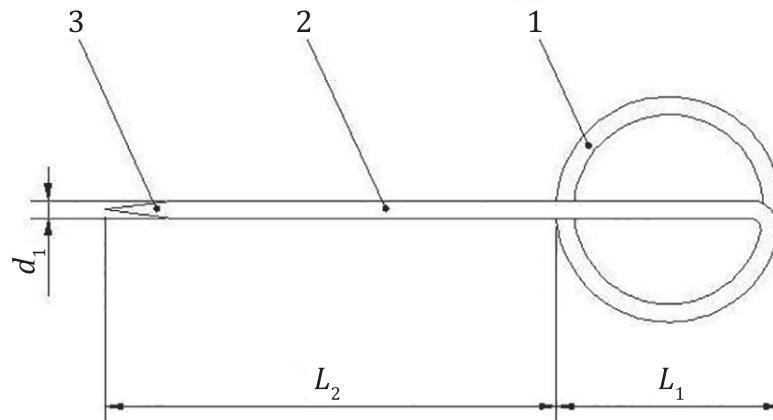

Key

1	handle of the needle	d_1	diameter of body of the needle
2	body of the needle	L_1	length of handle of the needle
3	tip of the needle	L_2	length of body of the needle

Figure 1 — Example of typical structure of intradermal granule type needle

4.2.2 Dimension of intradermal granule type needle

The nominal diameter of body of the needle and the length of body and handle of the needle shall be measured using a gauge specified in [Table 1](#) (see [Figure 1](#)).

Table 1 — Nominal dimension of intradermal granule type needle

Part		Nominal dimensions mm	Tolerance
The body of the needle	Nominal diameter d_1	$d < 0,40$	$\pm 10\%$
	Nominal length L_2	$L_2 < 5$	$\pm 0,5$
		$5 \leq L_2 < 10$	$\pm 0,8$
		$10 \leq L_2 \leq 30$	$\pm 1,0$
The handle of the needle	Nominal length L_1	$1,6 \leq L_1$	

4.3 Structure and dimension of intradermal thumbtack type needle

4.3.1 Structure of intradermal thumbtack type needle

The intradermal thumbtack type needle shall have the structure as shown in [Figure 2](#) and be composed of the body of the needle, the handle of the needle and the tape (in some cases). The type of needle handles are not limited to those shown in [Figure 2](#).

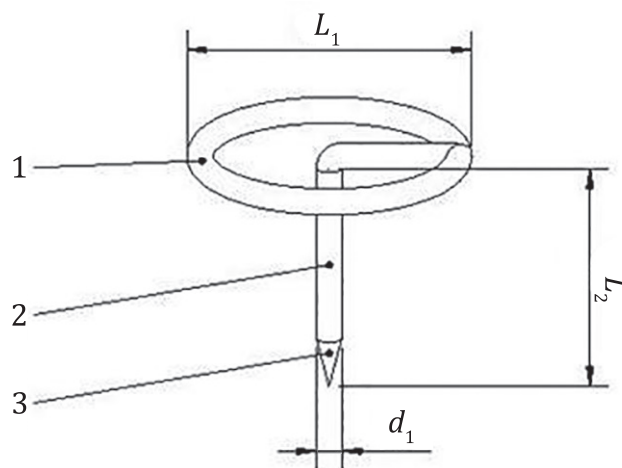

Key

- | | | | |
|---|----------------------|-------|--------------------------------|
| 1 | handle of the needle | d_1 | diameter of body of the needle |
| 2 | body of the needle | L_1 | length of handle of the needle |
| 3 | tip of the needle | L_2 | length of body of the needle |

Figure 2 — Example of typical structure of intradermal thumbtack type needle

4.3.2 Dimension of intradermal thumbtack type needle

The nominal diameter and the length of the body of the needle, and the nominal length and the diameter of the handle of the needle shall be measured using a gauge specified in [Table 2](#) (see [Figure 2](#)).

Table 2 — Nominal dimension of intradermal thumbtack type needle

Part		Nominal dimensions mm	Tolerance
The body of the needle	Nominal diameter d_1	$d_1 < 0,40$	$\pm 10 \%$
	Nominal length L_2	$L_2 < 3$	$\pm 0,5$
		$3 \leq L_2 < 5$	$\pm 0,8$
	$5 \leq L_2 \leq 30$	$\pm 1,0$	
The handle of the needle	Nominal length L_1	$2 \leq L_1$	

5 Materials

5.1 General

The biocompatibility of the body of the needle, the tape and the coating shall be assessed and documented according to the guidance and principles given in ISO 10993-1.

Compliance is demonstrated by

- a) analogy with published data,
- b) the selection of materials already shown to be biocompatible by proven clinical use in a similar application,
- c) experience with similar devices already on the market together with evidence of traceability to the materials used in the acupuncture needle, or
- d) compliance with published procedures for biological evaluation of medical devices.

If the material of the body of the needle or tape is changed and/or if there is a new coating applied to the surface of the needle body, and if there is risk that the new material or coating may cause adverse side effects to human tissue, then testing should be conducted in accordance with ISO 10993 series.

5.2 Body of intradermal acupuncture needle

There is no uniform regulation regarding materials of the needle handle and body. Currently, the most popular material for the needle body consists of X5CrNi18-9, X7CrNi18-9 Austenite Stainless Steel, etc., which are listed in ISO 15510.

6 Performance requirements

6.1 Appearance and cleanliness

When observed under a microscope of low magnifications ($\times 10$), the intradermal acupuncture needle shall not have roughness, grooves, rust, twist and/or bending. When observed under a microscope of medium or high magnifications ($\times 20$ or higher), the tip of the needle shall not have scars, foreign matters, broken or stumpy parts, bending, peeling surface coat and residual substances such as various solvents as used, fine metal particles which may be created in the process of cutting and grinding.

6.2 Drawing strength

The body of the needle shall be solidly joined to the handle of the needle.

When the minimum static force given in [Table 3](#) is applied in the direction of the centre axis of the body of the needle depending on the length of the body of the needle, it shall not be drawn out of the handle of the needle.

Table 3 — Force to test drawing strength

Nominal length of needle body, L_2 mm	Force N
$L_2 < 2$	1,5
$2 \leq L_2 < 5$	3
$5 \leq L_2 \leq 30$	5

6.3 Hardness of the needle body

Apply ISO 17218:2014, 5.3.3.

6.4 Intensity and puncture performance of the needle tip

Apply ISO 17218:2014, 5.3.5.

6.5 Sterility

The sterile intradermal acupuncture needle shall be sterilized through a validated sterilization process in order to ensure that the products are sterile.

In case of using ethylene oxide gas, testing for the residues of ethylene oxide shall comply with ISO 10993-7.

Appropriate sterilization methods can be found in the Bibliography. Requirements for validation and routine control of a sterilization process for medical devices can be found in ISO 11135, ISO 11137-1 and ISO 17665-1.

7 Packing and identification

7.1 Primary packaging

Sterile intradermal acupuncture needle shall be sealed in a primary package. There shall be no foreign matter within the primary package under visual inspection.

7.1.1 Packing method

Primary packaging of intradermal acupuncture needle shall be sealed so as to prevent opening due to pressure or light shock. Primary packaging shall, once opened, be unable to be sealed again. Primary packaging shall be sealed so as to prevent intradermal acupuncture needles from opening due to mishandling. Primary package should be ensured with adequate protection of the contents during normal handling, transit and storage. Primary packaging may be transparent on one or more sides to confirm the contents.

7.1.2 Identification

The symbols to be used with device labels, labelling and information to be supplied on the package shall comply with ISO 15223-1.

The primary package shall be marked with at least the following information:

- a) the name or trademark or logo of the manufacturer and/or supplier;
- b) a description of the contents, including the designated metric size in accordance with [5.2](#);
- c) the lot number, prefixed by the word "LOT", and/or date of manufacture;
- d) expiry date;
- e) method of sterilization, the word "STERILE" or symbol;
- f) the words "For single use" or "Do not reuse" or symbol.

NOTE See ISO 17218:2014, 7.2

7.2 Secondary packaging

7.2.1 Packing method

Secondary packaging of intradermal acupuncture needle shall be made to prevent the contents from being damaged during transportation and storage. Secondary package shall be sufficiently robust to protect the contents during handling, transit and storage.

7.2.2 Identification

The symbols to be used with device labels, labelling and information to be supplied on the package shall comply with ISO 15223-1.

The secondary package shall be marked with at least the following information:

- a) the name, address and trademark of the manufacturer and/or supplier;
- b) a description of the contents, including the designated metric size in accordance with [5.2](#), the quantity and the type;
- c) the lot number, prefixed by the word “LOT”, and/or date of manufacture;
- d) expiry date;
- e) method of sterilization, the word “STERILE” or symbol;
- f) the words “For single use” or “Do not reuse” or symbol;
- g) information for handling, storage and transportation;
- h) a warning to check the integrity of each primary package before use, such as “Do not use if package is damaged” or symbol;
- i) if used, the names or composition of additives (such as lubricant) used as a coating on the surface of needle body;
- j) if appropriate, those who are allergic to the material of the needle body should use with caution or follow the instruction of an acupuncture physician.

NOTE See ISO 17218:2014, 7.3

Bibliography

- [1] ISO 780, *Packaging — Distribution packaging — Graphical symbols for handling and storage of packages*
- [2] ISO 2859-1, *Sampling procedures for inspection by attributes — Part 1: Sampling schemes indexed by acceptance quality limit (AQL) for lot-by-lot inspection*
- [3] ISO 3696, *Water for analytical laboratory use — Specification and test methods*
- [4] ISO 6507-1, *Metallic materials — Vickers hardness test — Part 1: Test method*
- [5] ISO 6507-2, *Metallic materials — Vickers hardness test — Part 2: Verification and calibration of testing machines*
- [6] ISO 6507-3, *Metallic materials — Vickers hardness test — Part 3: Calibration of reference blocks*
- [7] ISO 6507-4, *Metallic materials — Vickers hardness test — Part 4: Tables of hardness values*
- [8] ISO 7000, *Graphical symbols for use on equipment — Registered symbols*
- [9] ISO 7864, *Sterile hypodermic needles for single use*
- [10] ISO 9626:1991/Amd 1:2001, *Stainless steel needle tubing for the manufacture of medical devices/Amendment 1*
- [11] ISO 10282, *Single-use sterile rubber surgical gloves — Specification*
- [12] ISO 11135, *Sterilization of health-care products — Ethylene oxide — Requirements for the development, validation and routine control of a sterilization process for medical devices*
- [13] ISO 11137-1, *Sterilization of health care products — Radiation — Part 1: Requirements for development, validation and routine control of a sterilization process for medical devices*
- [14] ISO 11137-2, *Sterilization of health care products — Radiation — Part 2: Establishing the sterilization dose*
- [15] ISO 11138-1, *Sterilization of health care products — Biological indicators — Part 1: General requirements*
- [16] ISO 11138-2, *Sterilization of health care products — Biological indicators — Part 2: Biological indicators for ethylene oxide sterilization processes*
- [17] ISO 11607-1, *Packaging for terminally sterilized medical devices — Part 1: Requirements for materials, sterile barrier systems and packaging systems*
- [18] ISO 11607-2, *Packaging for terminally sterilized medical devices — Part 2: Validation requirements for forming, sealing and assembly processes*
- [19] ISO 11737-1, *Sterilization of medical devices — Microbiological methods — Part 1: Determination of a population of microorganisms on products*
- [20] ISO 11737-2, *Sterilization of medical devices — Microbiological methods — Part 2: Tests of sterility performed in the definition, validation and maintenance of a sterilization process*
- [21] ISO 13485, *Medical devices — Quality management systems — Requirements for regulatory purposes*
- [22] ISO 14971, *Medical devices — Application of risk management to medical devices*

- [23] ISO 15223-2, *Medical devices — Symbols to be used with medical device labels, labelling, and information to be supplied — Part 2: Symbol development, selection and validation*
- [24] ISO 15510, *Stainless steels — Chemical composition*
- [25] ISO 17665-1, *Sterilization of health care products — Moist heat — Part 1: Requirements for the development, validation and routine control of a sterilization process for medical devices*
- [26] EN 1041:2008+A1:2013, *Information supplied by the manufacturer of medical devices*
- [27] EN 10088-1: 2014, *Stainless steels — List of stainless steels*
- [28] WFAS STANDARD — 001:2012, *Acupuncture needles*
- [29] GB/T 1031-2009, *Surface roughness parameters and their values*
- [30] GB 2024-1994, *Acupuncture needles*
- [31] GB/DRT 2024-2010, *Acupuncture needles (Draft standard)*
- [32] JIS T 9301:2005, *Acupuncture needle for single use*
- [33] KS P 3007:2009, *Sterile disposable acupuncture needle*
- [34] YY 0105-93, *Press needle*
- [35] YY 0043-2005, *Medical suture needle*
- [36] YY/T 0149-2006, *Medical instruments of stainless steel — Test methods of corrosive resistance*
- [37] YY 0666-2008, *Method for the test of sharpness and strength of needles tips*
- [38] 93/42/EEC, Council Directive 93/42/EEC of 14 June 1993 concerning medical devices
- [39] 2007/47/EC, Directive of the European Parliament and of the Council of 5 September 2007 amending Council Directive 90/385/EEC on the approximation of the laws of the Member States relating to active implantable medical devices, Council Directive 93/42/EEC concerning medical devices and Directive 98/8/EC concerning the placing of biocidal products on the market
- [40] WHO International Standard Terminologies on Traditional Medicine in the Western Pacific Region

British Standards Institution (BSI)

BSI is the national body responsible for preparing British Standards and other standards-related publications, information and services.

BSI is incorporated by Royal Charter. British Standards and other standardization products are published by BSI Standards Limited.

About us

We bring together business, industry, government, consumers, innovators and others to shape their combined experience and expertise into standards-based solutions.

The knowledge embodied in our standards has been carefully assembled in a dependable format and refined through our open consultation process. Organizations of all sizes and across all sectors choose standards to help them achieve their goals.

Information on standards

We can provide you with the knowledge that your organization needs to succeed. Find out more about British Standards by visiting our website at bsigroup.com/standards or contacting our Customer Services team or Knowledge Centre.

Buying standards

You can buy and download PDF versions of BSI publications, including British and adopted European and international standards, through our website at bsigroup.com/shop, where hard copies can also be purchased.

If you need international and foreign standards from other Standards Development Organizations, hard copies can be ordered from our Customer Services team.

Copyright in BSI publications

All the content in BSI publications, including British Standards, is the property of and copyrighted by BSI or some person or entity that owns copyright in the information used (such as the international standardization bodies) and has formally licensed such information to BSI for commercial publication and use.

Save for the provisions below, you may not transfer, share or disseminate any portion of the standard to any other person. You may not adapt, distribute, commercially exploit, or publicly display the standard or any portion thereof in any manner whatsoever without BSI's prior written consent.

Storing and using standards

Standards purchased in soft copy format:

- A British Standard purchased in soft copy format is licensed to a sole named user for personal or internal company use only.
- The standard may be stored on more than 1 device provided that it is accessible by the sole named user only and that only 1 copy is accessed at any one time.
- A single paper copy may be printed for personal or internal company use only.

Standards purchased in hard copy format:

- A British Standard purchased in hard copy format is for personal or internal company use only.
- It may not be further reproduced – in any format – to create an additional copy. This includes scanning of the document.

If you need more than 1 copy of the document, or if you wish to share the document on an internal network, you can save money by choosing a subscription product (see 'Subscriptions').

Reproducing extracts

For permission to reproduce content from BSI publications contact the BSI Copyright & Licensing team.

Subscriptions

Our range of subscription services are designed to make using standards easier for you. For further information on our subscription products go to bsigroup.com/subscriptions.

With **British Standards Online (BSOL)** you'll have instant access to over 55,000 British and adopted European and international standards from your desktop. It's available 24/7 and is refreshed daily so you'll always be up to date.

You can keep in touch with standards developments and receive substantial discounts on the purchase price of standards, both in single copy and subscription format, by becoming a **BSI Subscribing Member**.

PLUS is an updating service exclusive to BSI Subscribing Members. You will automatically receive the latest hard copy of your standards when they're revised or replaced.

To find out more about becoming a BSI Subscribing Member and the benefits of membership, please visit bsigroup.com/shop.

With a **Multi-User Network Licence (MUNL)** you are able to host standards publications on your intranet. Licences can cover as few or as many users as you wish. With updates supplied as soon as they're available, you can be sure your documentation is current. For further information, email subscriptions@bsigroup.com.

Revisions

Our British Standards and other publications are updated by amendment or revision.

We continually improve the quality of our products and services to benefit your business. If you find an inaccuracy or ambiguity within a British Standard or other BSI publication please inform the Knowledge Centre.

Useful Contacts

Customer Services

Tel: +44 345 086 9001

Email (orders): orders@bsigroup.com

Email (enquiries): cservices@bsigroup.com

Subscriptions

Tel: +44 345 086 9001

Email: subscriptions@bsigroup.com

Knowledge Centre

Tel: +44 20 8996 7004

Email: knowledgecentre@bsigroup.com

Copyright & Licensing

Tel: +44 20 8996 7070

Email: copyright@bsigroup.com

BSI Group Headquarters

389 Chiswick High Road London W4 4AL UK