

BS ISO 18738-2:2012



BSI Standards Publication

Measurement of ride quality

Part 2: Escalators and moving walks

bsi.

...making excellence a habit.™

National foreword

This British Standard is the UK implementation of ISO 18738-2:2012.

The UK participation in its preparation was entrusted to Technical Committee MHE/4, Lifts, hoists and escalators.

A list of organizations represented on this committee can be obtained on request to its secretary.

This publication does not purport to include all the necessary provisions of a contract. Users are responsible for its correct application.

© The British Standards Institution 2012.
Published by BSI Standards Limited 2012.

ISBN 978 0 580 66036 8

ICS 91.140.90

Compliance with a British Standard cannot confer immunity from legal obligations.

This British Standard was published under the authority of the Standards Policy and Strategy Committee on 31 December 2012.

Amendments issued since publication

Date	Text affected
------	---------------

INTERNATIONAL
STANDARD

ISO
18738-2

First edition
2012-10-15

Measurement of ride quality —
Part 2:
Escalators and moving walks

Mesure de la qualité de déplacement —

Partie 2: Escaliers mécaniques et trottoirs roulants



Reference number
ISO 18738-2:2012(E)

© ISO 2012



COPYRIGHT PROTECTED DOCUMENT

© ISO 2012

All rights reserved. Unless otherwise specified, no part of this publication may be reproduced or utilized in any form or by any means, electronic or mechanical, including photocopying and microfilm, without permission in writing from either ISO at the address below or ISO's member body in the country of the requester.

ISO copyright office
Case postale 56 • CH-1211 Geneva 20
Tel. + 41 22 749 01 11
Fax + 41 22 749 09 47
E-mail copyright@iso.org
Web www.iso.org

Published in Switzerland

Contents

Page

Foreword	iv
Introduction	v
1 Scope	1
2 Normative references	1
3 Terms and definitions	1
4 Measuring instrumentation	3
4.1 General.....	3
4.2 Characteristics.....	3
4.3 Processing of vibration data.....	4
4.4 Environmental effects.....	4
4.5 Sound measurement requirements.....	4
4.6 Calibration requirements.....	4
5 Measuring and reporting	5
5.1 General measuring conditions.....	5
5.2 General procedure.....	5
5.3 Vibration measurement.....	5
5.4 Sound measurement.....	9
5.5 Reporting of results.....	11
Annex A (informative) Ride quality corrected sound pressure estimation	14
Bibliography	16

Foreword

ISO (the International Organization for Standardization) is a worldwide federation of national standards bodies (ISO member bodies). The work of preparing International Standards is normally carried out through ISO technical committees. Each member body interested in a subject for which a technical committee has been established has the right to be represented on that committee. International organizations, governmental and non-governmental, in liaison with ISO, also take part in the work. ISO collaborates closely with the International Electrotechnical Commission (IEC) on all matters of electrotechnical standardization.

International Standards are drafted in accordance with the rules given in the ISO/IEC Directives, Part 2.

The main task of technical committees is to prepare International Standards. Draft International Standards adopted by the technical committees are circulated to the member bodies for voting. Publication as an International Standard requires approval by at least 75 % of the member bodies casting a vote.

Attention is drawn to the possibility that some of the elements of this document may be the subject of patent rights. ISO shall not be held responsible for identifying any or all such patent rights.

ISO 18738-2 was prepared by Technical Committee ISO/TC 178, *Lifts, escalators and moving walks*.

ISO 18738 consists of the following parts, under the general title *Measurement of ride quality*:

- *Part 1: Lifts (elevators)*
- *Part 2: Escalators and moving walks*

Introduction

The objective of this part of ISO 18738 is to encourage industry-wide uniformity in the definition, measurement, processing and expression of vibration and noise signals that comprise ride quality of escalators and moving walks.

The aim of such uniformity is to benefit industry clients by reducing variability in the results of ride quality measurements caused by differences in the methods of acquiring and quantifying the signals.

This part of ISO 18738 is intended to be referred to by those parties interested in:

- a) developing manufacturing specifications and calibration methods for instrumentation;
- b) defining the scope of the specifications for ride quality in contracts; and
- c) measuring ride quality of escalators and moving walks in accordance with an international standard.

This part of ISO 18738 is intended to produce ride quality measurement methods and results which:

- a) are simple to understand without specialized knowledge of noise and vibration analysis;
- b) correlate well with human response to ensure plausibility; and
- c) are accountable via calibration procedures, which are traceable to national standards.

Experience in the escalator and moving walk industry has shown that passenger perception and sound pressure levels measured while travelling on an escalator or moving walk can be influenced by the presence of extraneous noise sources and by the acoustic characteristics of the environment in which the unit is installed. Additionally, the proximity of the escalator or moving walk to strong reflecting surfaces such as walls, ceilings or diagonally opposite units can also influence the sound pressure level measured. These influences can cause a sound pressure level measurement to significantly overestimate the sound level emitted exclusively by the unit.

In order to address this issue, this part of ISO 18738 defines the methodology for measuring sound pressure level that corresponds to passenger perception and additionally defines the methods that should be used if further understanding of the result is required in order to quantify the noise emitted by the unit as compared to the background or environmental contributions.

Measurement of ride quality —

Part 2: Escalators and moving walks

1 Scope

This part of ISO 18738 specifies requirements and methodology for the measurement and reporting of escalator and moving walk ride quality. This part of ISO 18738 does not specify acceptable or unacceptable ride quality values.

2 Normative references

The following referenced documents are indispensable for the application of this document. For dated references, only the edition cited applies. For undated references, the latest edition of the referenced document (including any amendments) applies.

ISO 2041, *Vibration and shock — Vocabulary*

ISO 8041, *Human response to vibration — Measuring instrumentation*

ISO 11201, *Acoustics — Noise emitted by machinery and equipment — Determination of emission sound pressure levels at a work station and at other specified positions in an essentially free field over a reflecting plane with negligible environmental*

ISO 11205, *Acoustics — Noise emitted by machinery and equipment — Engineering method for the determination of emission sound pressure levels in situ at the work station and at other specified positions using sound intensity*

IEC 61043, *Electroacoustics — Instruments for the measurement of sound intensity — Measurements with pairs of pressure sensing microphones*

IEC 61672-1, *Sound level meters*

IEC 61672-2, *Calibration sound level meters*

3 Terms and definitions

For the purposes of this document, the terms and definitions given in ISO 2041, ISO 11201, ISO 11205 and the following apply.

3.1

load carrying unit

part of an escalator or moving walk designed to carry persons for the purpose of transportation

EXAMPLE Step, pallet or belt.

3.2

ride quality

sound pressure levels at defined locations, and vibration of load carrying unit and handrail relevant to passenger perception, associated with escalator or moving walk operation

3.3 acceleration

rate of change of velocity

NOTE 1 The direction is according to Figures 1 to 4.

NOTE 2 It is expressed in metres per second squared (m/s^2) or Galileo (Gal). $1 \text{ Gal} = 0,01 \text{ m/s}^2$ $1 \text{ m/s}^2 = 100 \text{ Gal}$.

3.4 vibration

variation with time of the magnitude of acceleration

NOTE It is expressed in metres per second squared (m/s^2) or Galileo (Gal). $1 \text{ Gal} = 0,01 \text{ m/s}^2$ $1 \text{ m/s}^2 = 100 \text{ Gal}$.

3.5 velocity

rate of change of displacement

NOTE 1 The direction is according to Figures 1 to 4.

NOTE 2 Velocity is reported as speed in direction of travel. It is given in metres per second (m/s).

3.6 sound pressure level

L_p
ten times the logarithm to the base 10 of the ratio of the square of the sound pressure to the square of the reference sound pressure

NOTE The reference sound pressure level is $20 \mu\text{Pa}$ ($2 \times 10^{-5} \text{ Pa}$).

3.7 equivalent sound pressure level

L_{pAeq}
average A-weighted sound pressure level

3.8 emission sound pressure level

L_{pA}
A-weighted sound pressure level at the specified positions, excluding the effects of background noise and contribution due to the room characteristics (reverberation) of the in-situ environment

NOTE It is expressed in decibels.

3.9 background noise correction

K_{1A}
correction term to account for the influence of background noise on the emission sound pressure level at the specified positions of the machine under test

NOTE The correction in the case of A-weighting is to be determined from A-weighted measured values.

3.10 environmental indicator

K_{2A}
correction term to account for the influence of reflected sound on the emission sound pressure level due to the characteristic of the test room

3.11 measured speed

speed of the escalator or moving walk with no load measured at the time of testing after the starting sequence has been completed

3.12

nominal speed

speed of the escalator or moving walk under no load stated by the manufacturer for which the escalator or moving walk has been designed

4 Measuring instrumentation

4.1 General

The measuring instrumentation shall consist of:

- a) a transducer to measure acceleration in each of the three orthogonal axes combined with a data acquisition system;
- b) a transducer to measure sound pressure level and/or sound intensity level.

4.2 Characteristics

The characteristics of the vibration measuring instrumentation shall be as described in Table 1.

Table 1 — Characteristics of vibration measuring instrumentation

Characteristic	Vibration load carrying unit	Vibration handrail
Frequency weighting	Whole body combined (see ISO 8041)	Hand-arm (see ISO 8041)
Band limiting	See ISO 8041	See ISO 8041
Accuracy ^a	Type 1 (see ISO 8041)	Type 1 (see ISO 8041)
Time weighting	1 sec rms (see ISO 8041)	1 sec rms (see ISO 8041)
Environmental	See ISO 8041	See ISO 8041
Resolution	0,005 m/s ²	0,005 m/s ²
Measurement range	20 % above max. instantaneous acceleration to 20 % below min. instantaneous acceleration ^b	20 % above max. instantaneous acceleration to 20 % below min. instantaneous acceleration ^b
^a The signals shall be filtered to exclude aliasing.		
^b A range of -1,5 m/s ² to + 1,5 m/s ² should meet the above requirement.		

The characteristics of the sound measuring instrumentation shall be as described in Table 2.

Table 2 — Characteristics of sound measuring instrumentation

Measurement	Ride quality — Sound pressure	Emission — Sound pressure level	Emission sound pressure
Characteristic		ISO 11201	ISO 11205
Method	Sound pressure	Sound pressure	Sound intensity (see ISO 11205)
Frequency weighting	A-weighting (see IEC 61672)	A-weighting (see IEC 60651)	A-weighting (see IEC 61043)
Frequency range	Not required	Not required	Octave 63 – 8 000 Hz Third 50 – 6 300 Hz
Accuracy ^a	Class 2 (see IEC 61672)	Class 1 (see IEC 1672)	Type 1 (see IEC 61043)
Measurement time interval	≥15 s, fast	≥15 s, fast	≥15 s
Environmental	See IEC 61672	See IEC 61672	See IEC 61043
Resolution	0,7 dB	0,7 dB	0,7 dB
Measurement range	35 to 90 dB A-weighted	30 to 90 dB A-weighted	See IEC 61043
^a The signals shall be filtered to exclude aliasing.			

4.3 Processing of vibration data

Vibration data shall be weighted in accordance with ISO 8041 to simulate the human body's response to vibration.

The acceleration signals in the x -, y - and z -axes, measured on the running load carrying unit, shall be frequency weighted using whole body combined filter and band limiting as defined in ISO 8041. The weighted signals, expressed as rms levels with a time constant of 1 sec, shall be evaluated as a vector sum.

The acceleration signals in the x_h -axes, measured on the running handrail, shall be frequency weighted using 'hand-arm' filter and band limiting as defined in ISO 8041 and expressed as rms levels with a time constant of 1 sec.

The sample rate of the digital measuring system shall be sufficient to enable the measuring range in accordance with ISO 8041.

4.4 Environmental effects

The instrumentation shall comply with the criteria for mechanical vibration, temperature range and humidity range, specified in ISO 8041.

4.5 Sound measurement requirements

The sound measuring system shall comply with the following.

- For ride quality sound pressure: the requirements of IEC 61672, Class 2, sound level meters.
- For emission sound pressure: the requirements of IEC 61672, Class 1, sound level meters or with the requirements of IEC 61043, Type 1, sound intensity meter.

The output shall be expressed in A-weighted decibels with respect to a reference sound pressure level (SPL) of 20 μ Pa.

4.6 Calibration requirements

All instrumentation calibrations shall be traceable to a national standard.

4.6.1 Vibration measuring system

The vibration measuring system shall be calibrated in accordance with ISO 8041.

4.6.2 Sound measuring system

Calibration of the sound measuring system shall be carried out in accordance with IEC 61672, Class 2 sound level meters, for ride quality sound pressure measurements.

Calibration of the sound measuring system shall be carried out in accordance with IEC 61672, Class 1 sound level meters or IEC 61043, Type 1, sound intensity meter, for emission pressure.

5 Measuring and reporting

5.1 General measuring conditions

The escalator or moving walk should be measured in both running directions except where the unit is designed to operate in one direction only. In this case it is sufficient to measure the unit only in this direction.

The measurement shall be carried out under the following conditions.

The unit shall

- be assembled completely, adjusted and operating in accordance with the operating manual;
- have reached normal operating temperature;
- be measured in an unloaded condition;
- be measured after the starting sequence has been completed. If the unit operates at different speeds, all speeds shall be measured. This refers only to speeds for passenger transportation;
- have finished star/delta change over, if used, before starting the measurement. This is in order to avoid faulty measuring values.

5.2 General procedure

Collection of the specific data of the escalator or moving walk shall be according to 5.5.

The measurements should be taken at a time of day agreed by the parties involved, in order to prevent disputes over the possible effects of ambient noise.

5.3 Vibration measurement

5.3.1 Special measuring conditions

Vibrations outside the escalator or moving walk may not falsify measurement.

Generators of disturbances shall be shut down. If not possible, reference measurement on the load carrying unit and on the handrail of a stopped escalator or moving walk shall be carried out and reported.

The coupling of the transducer to the measuring object shall not influence the results in the used frequency range (filters of ISO 8041).

5.3.2 Procedure for load carrying unit vibration measurement

- Apply the transducer or measurement device on the centreline of the load carrying unit (see Figures 1 and 3) of the running escalator or moving walk after passing the intersection line between the load carrying unit and the landing;

- align the axes of the transducer to the axes of the entire escalator or moving walk (see Figures 1 and 3);
- the transducer or measurement device shall remain in stable contact with the measuring surface throughout the measuring process. A contact pressure on the measuring surface of not less than 60 kPa is required, which is approximately the pressure of a human foot (see ISO 18738:2003, 7.2.2);
- the operator shall stand on the step/pallet tread surface directly behind the step/pallet being measured. In the case of a belted load carrying unit, the operator shall not stand within 300 mm of the transducer;
- start the measurement immediately after the transducer is placed for a horizontal moving walk;
- start the measurement at the beginning of the inclined area for an escalator or an inclined moving walk;
- stop the measurement as close as possible to the opposite landing for a horizontal moving walk;
- stop the measurement just before the inclined area intersects the transition curve for an escalator or an inclined moving walk.

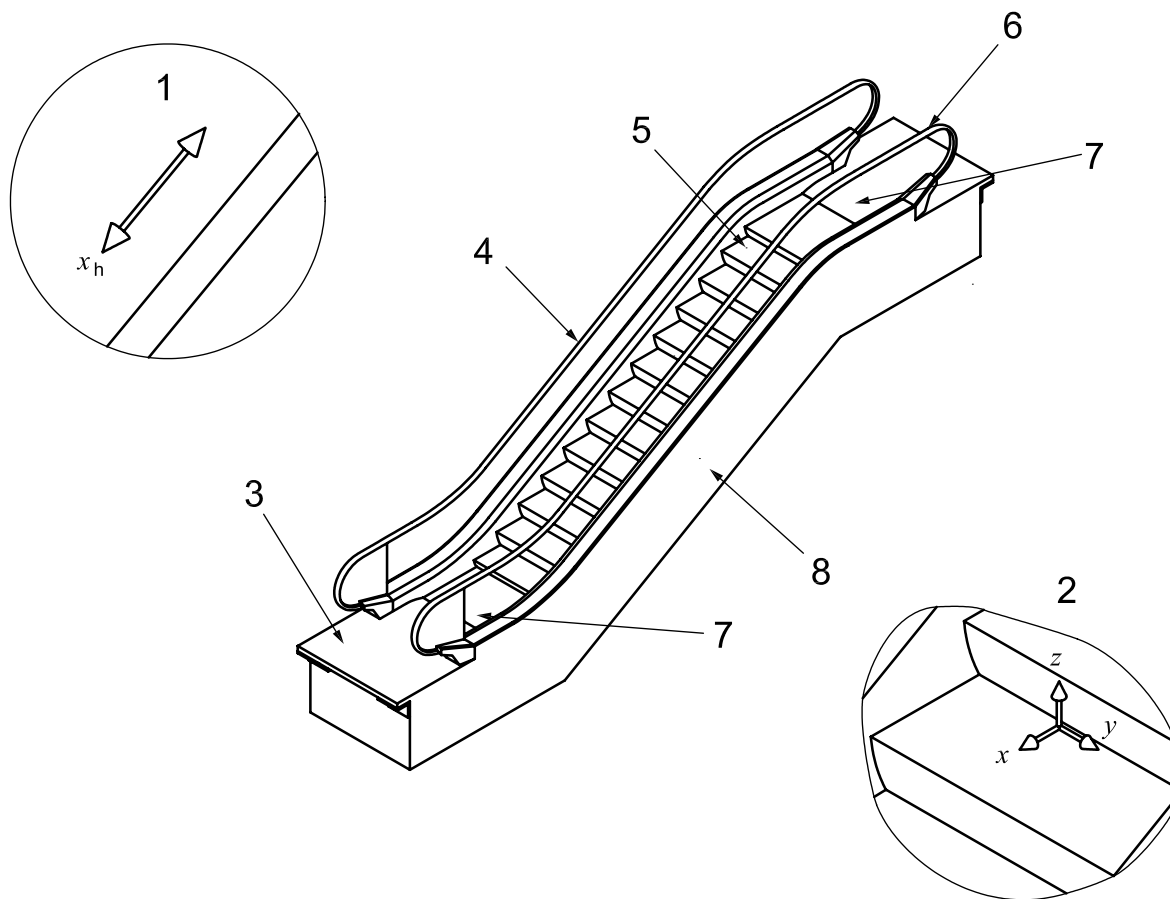

Key

- 1 axes of handrail
- 2 axes of escalator
- 3 lower landing
- 4 left side
- 5 load carrying unit
- 6 upper landing
- 7 intersection line
- 8 right side

Figure 1 — Escalator terminology and axes

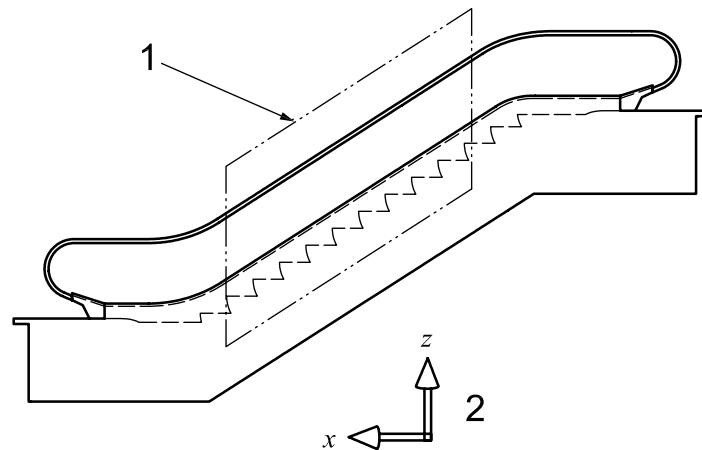

Key

- 1 inclined area or path of travel
- 2 axes of escalator

Figure 2 — Inclined area

5.3.3 Procedure for handrail vibration measurement

- Apply the transducer on one of the handrails of the running escalator or moving walk in the landing area;
- align the x -axis of the transducer to the x_h -axis of the handrail (see Figures 1 and 3);
- fix the transducer by hand;
- start the measurement at the beginning of the inclined area (see Figures 2 and 4) for an escalator or inclined moving walk or directly after fixing the transducer to the handrail for horizontal moving walks;
- stop the measurement at the end of the inclined area or upon passing above the intersection line between the landing and the load carrying unit for an horizontal moving walk.

Repeat the procedure for the second handrail.

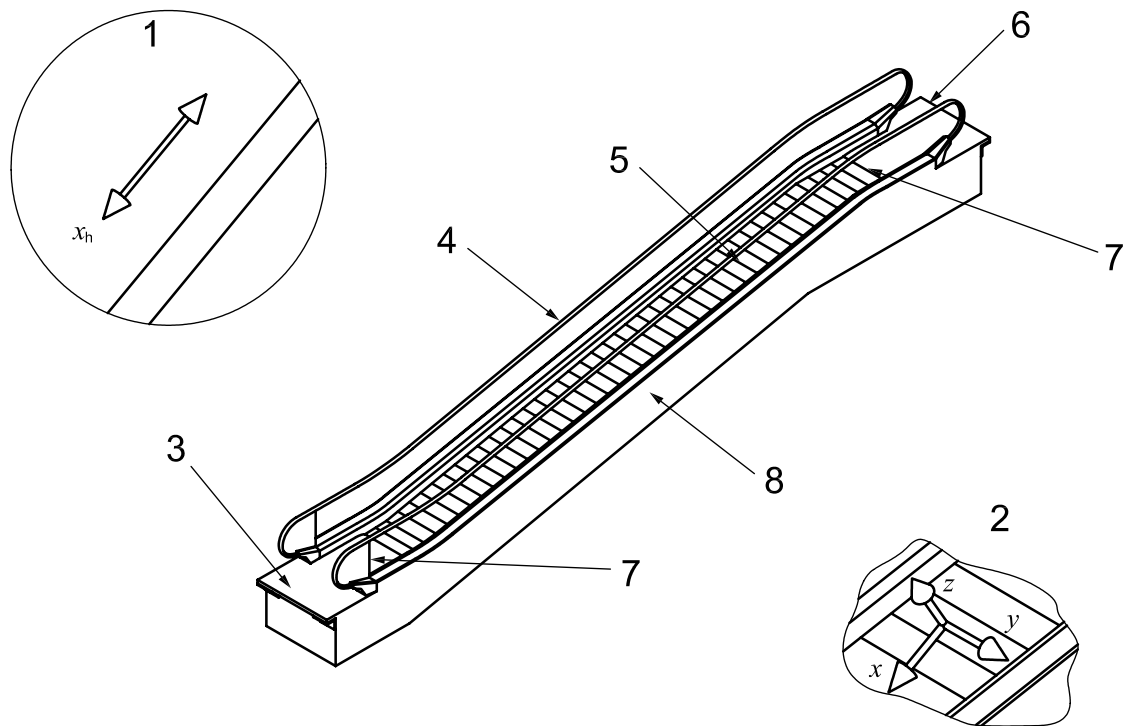

Key

- 1 axes of handrail
- 2 axes of moving walk
- 3 lower landing
- 4 left side
- 5 load carrying unit
- 6 upper landing
- 7 intersection line
- 8 right side

Figure 3 — Moving walk terminology

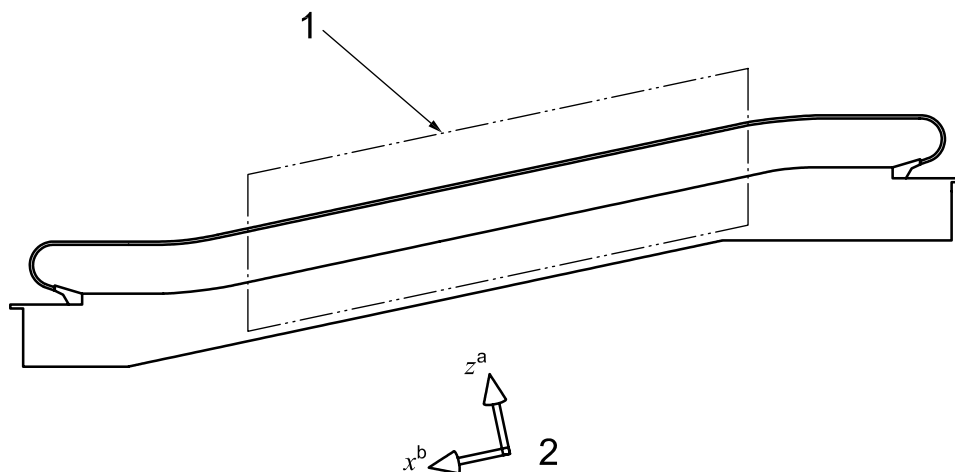

Key

- 1 inclined area or path of travel
- 2 axes of moving walk
- a perpendicular to surface (z-axis)
- b parallel to surface (x-axis)

Figure 4 — Inclined area

5.4 Sound measurement

The sound level measured at the specified positions defined below determines the ride quality experienced by the passenger relative to noise levels. The measured sound level is the sum of:

- a) emission sound level of the escalator or moving walk;
- b) background noise level;
- c) acoustic characteristics of the room where the unit is installed (i.e., reverberation characteristics of the entire room); and
- d) acoustic reflection from hard surfaces other than the floor in the near field of the pressure measurement.

Emission methods specified below shall be used to determine the sound levels directly emitted by the escalator or moving walk, which are independent of the background or acoustic room characteristic, when emission pressure measurements are required.

5.4.1 Special measuring conditions

Sound outside the escalator or moving walk may not invalidate the measurement. Generators of external disturbances shall be shut down.

5.4.2 Microphone positions

The general measuring distance to the floor/surface of steps and pallets is $H = 1,55 \text{ m} \pm 0,075 \text{ m}$.

The following microphone positions are predetermined for the sound pressure measurement:

- a) upper landing — 1m from the intersection line (see Figures 1 and 3) in the direction of the exit on the centreline and at the height H ;
- b) lower landing — 1m from the intersection line (see Figures 1 and 3) in the direction of the exit on the centreline and at the height H ;

- c) n : incline or path – moving along the path or the incline, on the centreline and at the height H , (see Figure 5).

Additional measurement locations that may be used for determining the emitted sound pressure levels within the incline are shown below as position ($i = n$). Position ($i = n$) may be selected so that noise emitted from a machine unit within the truss can be identified directly.

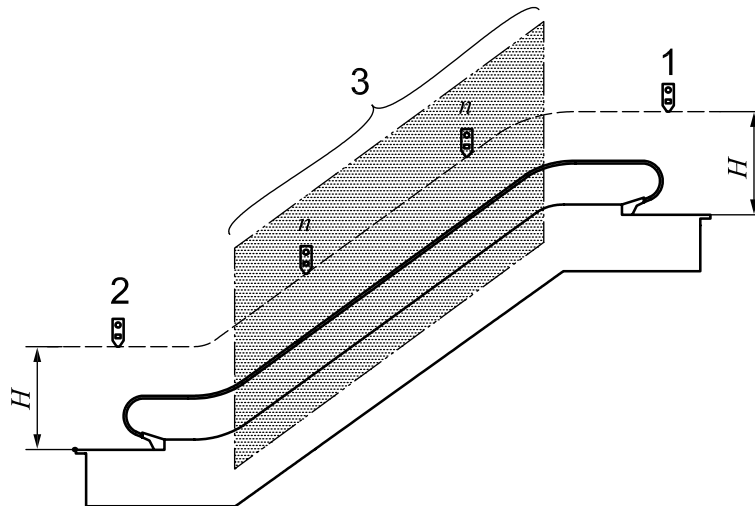

Key

1, 2, n	microphone positions
3	inclined area or path of travel
H	= 1,55 m \pm 0,075 m

Figure 5 — Microphone positions

5.4.3 Procedure for sound measurement

Ride quality sound pressure measurement and emission sound pressure measurement procedures are defined below.

Sound pressure measurement is used to assess the ride quality of the unit.

Emission sound pressure method is used to determine unit contribution to total sound pressure level, using accuracy grade 2 in ISO 11200, either by ISO 11201 (environment meets free-field condition) or ISO 11205. This is used where an accuracy of less than 5 dB is required.

5.4.3.1 Ride quality sound pressure level measurement

- Ambient measurement of environment: Measure the sound pressure (in dBA) of the background noise at every microphone position in Figure 5 ($i = 1, 2, n$) when the escalator or moving walk is switched off;
- measure the sound pressure (in dBA) at every microphone position in Figure 5 ($i = 1, 2, n$) when the Escalator or Moving Walk operates in the normal direction of travel. For units designed to be operated in either direction, both directions of travel should be measured;
- limitation for background noise: $\Delta L_p \geq 6$ dB (ΔL is the difference between the sound pressure level measured with the source under test in operation and the level of the background noise);
- a method to correct the ride quality sound pressure of the unit due to environmental contribution is given in Annex A for assessing the ride quality sound pressure measurement in the presence of strong environmental contributions, not for use where accuracy less than 5 dB is required.

5.4.3.2 Emission sound pressure level measurement

- Measure the sound pressure (in dBA) of the background noise at every microphone position in Figure 5 ($i = 1, 2, n$) when the escalator or moving walk is switched off;
- measure the sound pressure (in dBA) at every microphone position in Figure 5 ($i = 1, 2, n$) when the escalator or moving walk operates in the normal direction of travel. For units designed to be operated in either direction, both directions of travel should be measured;
- calculate ΔL_i – the difference between the sound pressure of the running escalator or moving walk and the background noise for all the positions in Figure 5 ($i = 1, 2, n$).
 - If $\Delta L_i < 6$ dB there is no possibility for sound measuring according to ISO 11205 and ISO 11201.
 - If ΔL_i is ≥ 6 dB and < 10 dB there is no possibility for sound measuring according ISO 11205. In this case determine the environmental indicator K_{2A} . If $K_{2A} \leq 2$ dB use ISO 11201 as measuring method.
 - If ΔL_i is ≥ 10 use the following as a measuring method:
 - ISO 11205 or
 - ISO 11201 if $K_{2A} \leq 2$ dB.

Table 3 — Sound measuring methods for escalators and moving walks

Characteristic	Sound ISO 11201	Sound ISO 11205
Method	Sound pressure	Sound intensity
Measuring environment	Flat outdoor area or indoor space that provides an essentially free field over a reflecting plane: $K_{2A} \leq 2$ dB	According to ISO 11205
Background noise level	$\Delta L \geq 6$ dBA	$\Delta L \geq 10$
Correction of background noise level	According to ISO 11201	Not applicable

5.5 Reporting of results

The results shall be reported as follows:

- a) general information:
 - date and time of the measurement;
 - name of the persons carrying out the measurement, and participants and name of the organization they belong to;
 - location/building, e.g. address, storage, location on the storage;
 - reason for the measurement;
- b) escalator or moving walk information:
 - manufacturer;
 - unit number;
 - month and year of construction;
 - model of escalator or moving walk;

- rise or length of the horizontal projection of the inclined part;
- angle of inclination;
- width;
- nominal speed of load carrying unit;
- general running direction for escalator or moving walk running only in one direction;
- general conditions (contamination, date of last maintenance);
- c) measuring instrument information:
 - manufacturer;
 - unit number;
 - date of last calibration;
 - version of software/firmware;
- d) disturbances (vibration, sound) from outside the escalator or moving walk;
- e) vibration measurement results:
 - results of the load carrying unit vibration measurement;
 - number of measurement;
 - measured speed of the load carrying unit;
 - running direction;
 - vibration level of load carrying unit:

Average RMS (Root Mean Square) and maximum RMS calculated as follows:

- filter row acceleration x, y, z values with whole body combined filter according to ISO 8041;
- calculate the RMS values (RMS time constant 1 s);
- calculate the vector sum of the x, y, z values;
- determine the maximum RMS and calculate the average RMS;
- results of the handrail vibration measurement:
 - number of measurement;
 - measured speed of the load carrying unit;
 - running direction;
 - measured handrail: left or right;
 - vibration level of the handrail:

Average RMS and maximum RMS calculated as follows:

- first filter row acceleration x values with hand arm filter according to ISO 8041;
- calculate the RMS values (RMS time-constant 1 s);
- determine the maximum RMS and calculate the average RMS;

- f) sound measurement results:
- ride quality reporting:
 - number of measurement;
 - microphone position;
 - ambient A-weighted sound pressure level at each microphone position;
 - running direction;
 - operating A-weighted sound pressure level at each microphone position;
 - emission sound pressure level reporting:
 - number of measurement;
 - microphone position;
 - ambient A-weighted sound pressure level at each microphone position;
 - running direction;
 - operating A-weighted sound pressure level at each microphone position;
 - emission A-weighted sound pressure level of running escalator or moving walk at each microphone position;
 - emission method used;
 - measurement uncertainty.

Annex A (informative)

Ride quality corrected sound pressure estimation

A.1 General

This annex presents a methodology for using sound pressure methods to estimate the contribution of the unit to the ride quality sound pressure level measured. This methodology provides a result with a reproducibility standard deviation greater than 5 dB and is not recommended for cases where the emission sound pressure level of the unit is required with accuracy less than that value. For cases where emission sound pressure level of the unit is required with accuracy less than 5 dB, ISO 11201 or ISO 11205 shall be used.

A.2 Measurement of corrected sound pressure

This annex presents a methodology for a means of measuring corrected sound pressure in a way to determine the sound pressure level created by the unit under test without the contributions from the environmental reverberation characteristics of the room or reflections from local adjacent walls, ceilings, or passing escalators. This methodology is not recommended when the *in situ* environment contains strong acoustic resonances that interact with the sound emitted by the unit under test.

The sound pressure measurement correction method corrects for local environmental effects of reverberation or reflection utilizing a sound source.

a) Ambient measurement of environment:

- 1) Measure the sound pressure (in dBA) of the background noise at every microphone position when the escalator or moving walk is switched off.

b) Sound source measurements:

- 1) Free-field characteristic: Measure the sound pressure (in dBA) of the sound source in the free field at the measuring height specified in 5.4.2, directly above the sound source.
- 2) Test environment characteristic: Measure the sound pressure (in dBA) of the sound source in the general environment where the unit is installed, at the height specified in 5.4.2, directly above the sound source. The source should be located a minimum of 3 m from any reflecting surface other than the floor at the height of the measurement microphone.
- 3) Escalator position characteristics: Measure the sound pressure (in dBA) of sound source at the microphone position on the escalator or moving walk as specified in 5.4.2, directly above the sound source, when the escalator or moving walk is switched off.

c) Determination of correction values for sound pressure measurements:

- 1) The difference between the sound source in the free field ($SPL_{s,0}$) and the sound source at microphone positions 1 and 2 ($SPL_{s,1}$ and $SPL_{s,2}$, respectively), shall be used for the correction values for microphone positions 1 and 2 (the upper and lower landing).

$$C_1 = SPL_{s,1} - SPL_{s,0} \quad (1)$$

$$C_2 = SPL_{s,2} - SPL_{s,0} \quad (2)$$

- 2) The presence of the balustrade prevents the normal attenuation of sound radiation from the sound source compared to the attenuation with distance that would occur in a hemispherical direction in the free field. This balustrade effect can be measured directly by measuring a known source in the free field and in the incline section of the balustrade, and comparing the results or by using Table A.1.
- 3) The difference between the sound source in the free field (SPL_{s0}) and the sound source at microphone position 3 or n (SPL_{s3} and SPL_{sn} , respectively), corrected for the local influence of the balustrades as defined in Table A.1, shall be used for the correction values for microphone positions 3 or n (the incline section).

$$C_3 = SPL_{s,0} - SPL_{s,3} + SPL_B \quad (3)$$

$$C_n = SPL_{s,0} - SPL_{s,n} + SPL_B \quad (4)$$

- 4) Measure the sound pressure (in dBA) at every microphone position (i) when the escalator or moving walk operates in both directions.

- i) SPL for microphone positions 1 and 2 (upper and lower landing) shall be determined by:

$$SPL_{1,C} = SPL_1 - C_1 \quad (5)$$

$$SPL_{2,C} = SPL_2 - C_2 \quad (6)$$

- ii) SPL for microphone positions 3 or n (incline section) shall be determined by:

$$SPL_{3,C} = SPL_3 - C_3 \quad (7)$$

$$SPL_{n,C} = SPL_n - C_n \quad (8)$$

- 5) Characteristics of the sound source – the sound source should meet the following criteria:

- i) stable output sound power level, regardless of power source;
- ii) a continuous, pink noise spectrum should be used, from 100 Hz to 8 kHz;
- iii) at a height measured 45° from the ground, the sound measured in a complete circle around the source should not vary more than 3 dB, when measured over a hard reflecting surface in an environment without significant reflections;
- iv) at one location of the circle, the sound measured from directly above the source (and arc 90 ° from the ground) in an arc 45 ° towards the ground should no vary more than 10 dB in any single octave band, when measured over a hard reflecting surface in an environment without significant reflections.

Table A.1 — Balustrade correction

Step band width	600 mm	800 mm	1 000 mm
SPL_B	5,5 dB	5 dB	3 dB

Bibliography

- [1] ISO 11200, *Acoustics — Noise emitted by machinery and equipment — Guidelines for the use of basic standards for the determination of emission sound pressure levels at a work station and at other specified positions*
- [2] ISO 18738: 2003, *Lifts (elevators) — Measurement of lift ride quality*

British Standards Institution (BSI)

BSI is the national body responsible for preparing British Standards and other standards-related publications, information and services.

BSI is incorporated by Royal Charter. British Standards and other standardization products are published by BSI Standards Limited.

About us

We bring together business, industry, government, consumers, innovators and others to shape their combined experience and expertise into standards-based solutions.

The knowledge embodied in our standards has been carefully assembled in a dependable format and refined through our open consultation process. Organizations of all sizes and across all sectors choose standards to help them achieve their goals.

Information on standards

We can provide you with the knowledge that your organization needs to succeed. Find out more about British Standards by visiting our website at bsigroup.com/standards or contacting our Customer Services team or Knowledge Centre.

Buying standards

You can buy and download PDF versions of BSI publications, including British and adopted European and international standards, through our website at bsigroup.com/shop, where hard copies can also be purchased.

If you need international and foreign standards from other Standards Development Organizations, hard copies can be ordered from our Customer Services team.

Subscriptions

Our range of subscription services are designed to make using standards easier for you. For further information on our subscription products go to bsigroup.com/subscriptions.

With **British Standards Online (BSOL)** you'll have instant access to over 55,000 British and adopted European and international standards from your desktop. It's available 24/7 and is refreshed daily so you'll always be up to date.

You can keep in touch with standards developments and receive substantial discounts on the purchase price of standards, both in single copy and subscription format, by becoming a **BSI Subscribing Member**.

PLUS is an updating service exclusive to BSI Subscribing Members. You will automatically receive the latest hard copy of your standards when they're revised or replaced.

To find out more about becoming a BSI Subscribing Member and the benefits of membership, please visit bsigroup.com/shop.

With a **Multi-User Network Licence (MUNL)** you are able to host standards publications on your intranet. Licences can cover as few or as many users as you wish. With updates supplied as soon as they're available, you can be sure your documentation is current. For further information, email bsmusales@bsigroup.com.

BSI Group Headquarters

389 Chiswick High Road London W4 4AL UK

Revisions

Our British Standards and other publications are updated by amendment or revision.

We continually improve the quality of our products and services to benefit your business. If you find an inaccuracy or ambiguity within a British Standard or other BSI publication please inform the Knowledge Centre.

Copyright

All the data, software and documentation set out in all British Standards and other BSI publications are the property of and copyrighted by BSI, or some person or entity that owns copyright in the information used (such as the international standardization bodies) and has formally licensed such information to BSI for commercial publication and use. Except as permitted under the Copyright, Designs and Patents Act 1988 no extract may be reproduced, stored in a retrieval system or transmitted in any form or by any means – electronic, photocopying, recording or otherwise – without prior written permission from BSI. Details and advice can be obtained from the Copyright & Licensing Department.

Useful Contacts:

Customer Services

Tel: +44 845 086 9001

Email (orders): orders@bsigroup.com

Email (enquiries): cservices@bsigroup.com

Subscriptions

Tel: +44 845 086 9001

Email: subscriptions@bsigroup.com

Knowledge Centre

Tel: +44 20 8996 7004

Email: knowledgecentre@bsigroup.com

Copyright & Licensing

Tel: +44 20 8996 7070

Email: copyright@bsigroup.com



...making excellence a habit.™