

BS ISO 18435-3:2015



BSI Standards Publication

Industrial automation systems and integration — Diagnostics, capability assessment and maintenance applications integration

Part 3: Applications integration description
method

bsi.

...making excellence a habit.™

National foreword

This British Standard is the UK implementation of ISO 18435-3:2015.

The UK participation in its preparation was entrusted to Technical Committee AMT/5, Industrial architectures and integration frameworks.

A list of organizations represented on this committee can be obtained on request to its secretary.

This publication does not purport to include all the necessary provisions of a contract. Users are responsible for its correct application.

© The British Standards Institution 2015. Published by BSI Standards Limited 2015

ISBN 978 0 580 80096 2

ICS 25.040.40

Compliance with a British Standard cannot confer immunity from legal obligations.

This British Standard was published under the authority of the Standards Policy and Strategy Committee on 31 August 2015.

Amendments issued since publication

Date	Text affected
------	---------------

INTERNATIONAL
STANDARD

ISO
18435-3

First edition
2015-08-01

**Industrial automation systems and
integration — Diagnostics, capability
assessment and maintenance
applications integration —**

Part 3:
**Applications integration description
method**

*Systèmes d'automatisation industrielle et intégration — Diagnostics,
évaluation des moyens et intégration des applications de
maintenance —*

Partie 3: Méthode de description pour l'intégration d'applications



Reference number
ISO 18435-3:2015(E)

© ISO 2015



COPYRIGHT PROTECTED DOCUMENT

© ISO 2015, Published in Switzerland

All rights reserved. Unless otherwise specified, no part of this publication may be reproduced or utilized otherwise in any form or by any means, electronic or mechanical, including photocopying, or posting on the internet or an intranet, without prior written permission. Permission can be requested from either ISO at the address below or ISO's member body in the country of the requester.

ISO copyright office
Ch. de Blandonnet 8 • CP 401
CH-1214 Vernier, Geneva, Switzerland
Tel. +41 22 749 01 11
Fax +41 22 749 09 47
copyright@iso.org
www.iso.org

Contents

Page

Foreword	iv
Introduction	v
1 Scope	1
2 Normative reference(s)	1
3 Terms and definitions	1
4 Abbreviated terms	2
5 Applications integration description methods	2
5.1 Introduction to the application integration concept.....	2
5.1.1 General.....	2
5.1.2 Inter-domain requirements.....	4
5.1.3 Intra-domain requirements.....	5
5.2 Profiling concept.....	6
5.2.1 General.....	6
5.2.2 Intra-domain information exchange compatibility.....	6
5.2.3 Inter-domain information exchange compatibility.....	7
5.3 Basic interoperability requirements for information exchange.....	8
5.4 Procedure for the construction of AIMEs and ADMEs.....	8
5.4.1 General.....	8
5.4.2 Application interoperability requirements.....	10
5.4.3 Specify content section.....	11
5.4.4 Specify resource and conveyance requirements.....	11
5.5 AIME requirements.....	11
5.5.1 General.....	11
5.5.2 AIME detailed requirements.....	11
5.6 Construction of the ADME.....	12
5.6.1 General.....	12
5.6.2 Technical dictionary selection.....	12
5.6.3 Application framework selection.....	12
5.6.4 Contents section.....	12
6 Compliance	12
Annex A (normative) Ontology in AIME/ADME	13
Annex B (informative) Smart Pump Information exchange example	20
Annex C (informative) Jam detection example	28
Annex D (informative) EtherNet/IP to OPC Information Exchange	33
Bibliography	38

Foreword

ISO (the International Organization for Standardization) is a worldwide federation of national standards bodies (ISO member bodies). The work of preparing International Standards is normally carried out through ISO technical committees. Each member body interested in a subject for which a technical committee has been established has the right to be represented on that committee. International organizations, governmental and non-governmental, in liaison with ISO, also take part in the work. ISO collaborates closely with the International Electrotechnical Commission (IEC) on all matters of electrotechnical standardization.

The procedures used to develop this document and those intended for its further maintenance are described in the ISO/IEC Directives, Part 1. In particular the different approval criteria needed for the different types of ISO documents should be noted. This document was drafted in accordance with the editorial rules of the ISO/IEC Directives, Part 2 (see www.iso.org/directives).

Attention is drawn to the possibility that some of the elements of this document may be the subject of patent rights. ISO shall not be held responsible for identifying any or all such patent rights. Details of any patent rights identified during the development of the document will be in the Introduction and/or on the ISO list of patent declarations received (see www.iso.org/patents).

Any trade name used in this document is information given for the convenience of users and does not constitute an endorsement.

For an explanation on the meaning of ISO specific terms and expressions related to conformity assessment, as well as information about ISO's adherence to the WTO principles in the Technical Barriers to Trade (TBT) see the following URL: [Foreword - Supplementary information](#)

The committee responsible for this document is Technical Committee ISO/TC 184, *Industrial automation systems and integration*, Subcommittee SC 5, *Architecture, communication and integration frameworks*.

ISO 18435 consists of the following parts, under the general title *Industrial automation systems and integration — Diagnostics, capability assessment, and maintenance applications integration*:

- *Part 1: Overview and general requirements*
- *Part 2: Descriptions and definitions of application domain matrix elements*
- *Part 3: Applications integration description method*

Introduction

ISO 18435 defines a set of integration methods intended to be used when integrating diagnostics, capability assessment, and maintenance applications with the applications in production, control, and other manufacturing operations.

ISO 18435-1 provides an overview of the elements as shown in [Figure 1](#) and the rules of a method to describe an automation application's integration requirements. The elements include the key aspects when integrating an automation application with other applications and the relationships of these key aspects. The rules include the information exchanges to support interoperability within an application and between applications.

ISO 18435-2 provides the detailed definitions of the Application Interaction Matrix Element (AIME) and Application Domain Matrix Element (ADME) structures and their relationships. In particular, the steps for constructing an ADME from a set of AIMEs are described.

This part of ISO 18435 defines a recommended method based on templates to describe the interoperability between applications in two or more automation domains within an enterprise, at all levels of an enterprise's functional and resource hierarchies. The focus is on the production operations and maintenance operations domains.

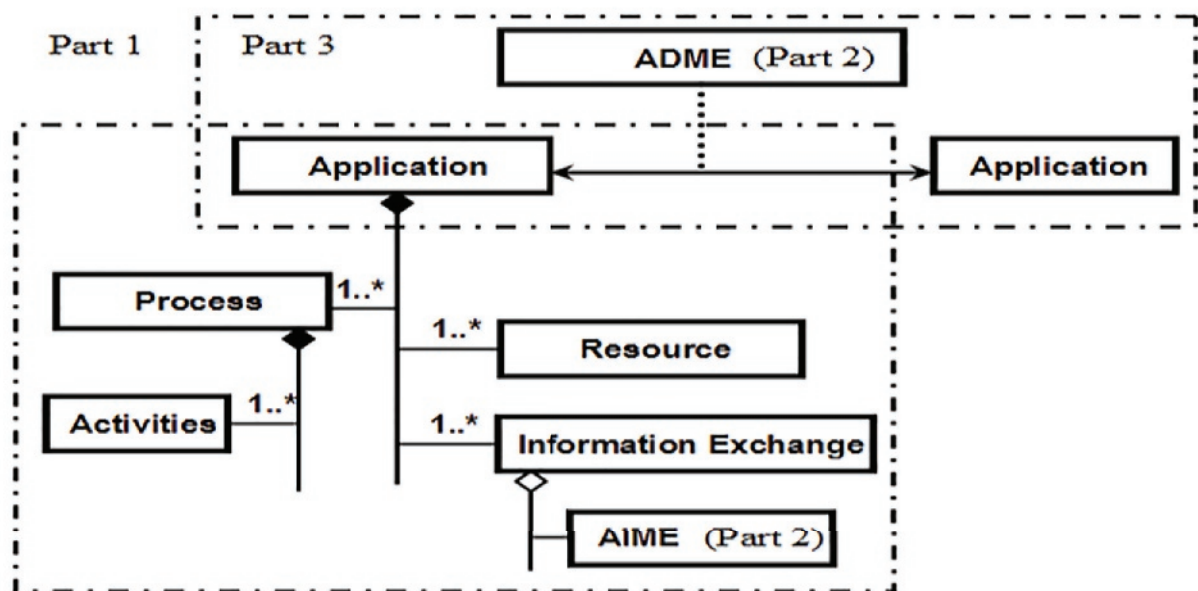

Figure 1 — Relationships between the parts of ISO 18435

UML is used to represent information exchange requirements associated with the interoperability and the integration of plant floor applications, in particular, diagnostics, control, maintenance and production.

The purpose is to focus on how to express the information exchanges:

- about the process, equipment, operators, and materials and other automation assets;
- that are conveyed from control and production systems to various diagnostics and maintenance systems in order to perform asset management.

The intended benefits for representing information exchanges are to:

- facilitate specifying and procuring open systems that support interoperability among diagnostics and maintenance applications;

- reduce the time to develop diagnostics and maintenance solutions that directly address the well-defined integration requirements;
- provide a means to categorize tools intended to enable and verify interoperability and integration across applications.

Industrial automation systems and integration — Diagnostics, capability assessment and maintenance applications integration —

Part 3: Applications integration description method

1 Scope

This part of ISO 18435 defines the profiling methodology to use the interoperability templates of ISO 18435-2. These profiling methods describe the construction and the use of application domain matrix elements (ADMEs), application interaction matrix elements (AIMEs), and an open technical dictionary (OTD) to support the information exchange.

In particular, this part of ISO 18435 gives guidance related to profiling the information exchange between two applications by establishing the context, conveyance, and contents defined in ISO 18435-2.

This part of ISO 18435 is intended to be used in conjunction with ISO 18435-1 and ISO 18435-2.

2 Normative reference(s)

The following documents, in whole or in part, are normatively referenced in this document and are indispensable for its application. For dated references, only the edition cited applies. For undated references, the latest edition of the referenced document (including any amendments) applies.

ISO 8000 (all parts), *Data quality*

ISO/IEC 10646, *Information technology — Universal Coded Character Set (UCS)*

ISO 15745-1, *Industrial automation systems and integration — Open systems application integration framework — Part 1: Generic reference description*

ISO 18435-1:2009, *Industrial automation systems and integration — Diagnostics, capability assessment and maintenance applications integration — Part 1: Overview and general requirements*

ISO 18435-2:2012, *Industrial automation systems and integration — Diagnostics, capability assessment and maintenance applications integration — Part 2: Descriptions and definitions of application domain matrix elements*

ISO/TS 29002 (all parts), *Industrial automation systems and integration — Exchange of characteristic data*

ISO/TS 29002-5:2009, *Industrial automation systems and integration — Exchange of characteristic data — Part 5: Identification scheme*

3 Terms and definitions

For the purposes of this document, the terms and definitions given in ISO 18435-1 and ISO 18435-2 and the following apply.

3.1 ontology

explicit and consensual specification of concepts of an application domain independent of any use of these concepts

[SOURCE: ISO 13584-511:2006, 3.1.20]

4 Abbreviated terms

ADME	Application Domain Matrix Element
AIME	Application Integration Matrix Element
CBM	Condition-Based Maintenance
OTD	Open Technical Dictionary
UML	Unified Modelling Language
XML	eXtensible Markup Language

5 Applications integration description methods

5.1 Introduction to the application integration concept

5.1.1 General

The customer applications integration requirements determine the information exchange profiles that are needed to support the application interoperability requirements. To develop the information exchange profiles for the applications of interest, it is necessary to determine the existing customer domain areas of interest.

[Clause 5](#) describes the method for specifying the information contained in the AIME and the ADME for the information exchange requirements using templates defined in ISO 18435-2. The use of this method will provide interoperability for the applications in the defined context. As this methodology is used for integrating additional applications from various domains, this method can be used for verifying if the information exchange profiles (using the AIME structure) are interoperable as needed by the user. [Figure 2](#) shows an iterative process to verify the intended interoperability of the application integration.

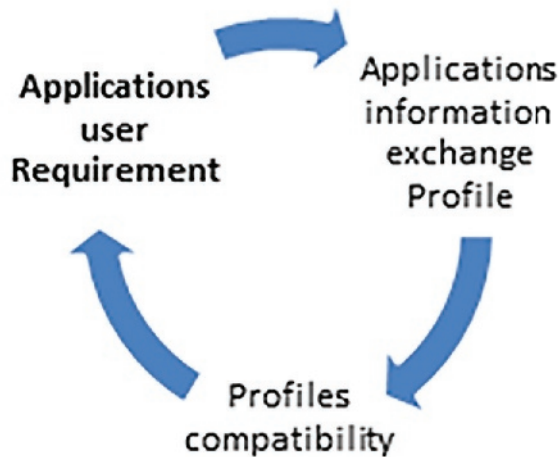

Figure 2 — System design cycle for interoperability

The general structure for the application information exchange profiles are depicted in Figure 3. The methods for assessing the AIME profile compatibility to support the information exchanges will depend upon the context and domains of interest.

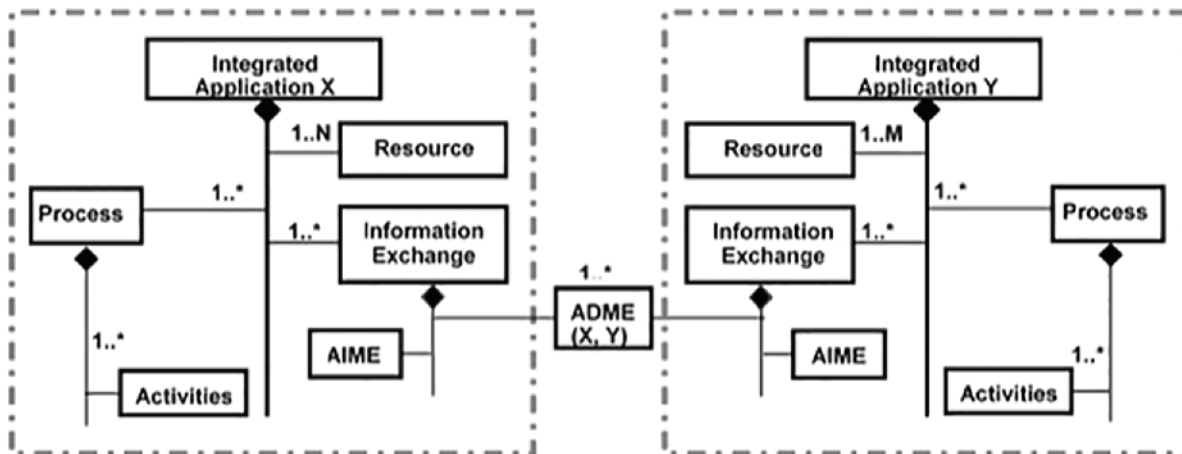

Figure 3 — Profile elements

The diagnostic and maintenance mission depends on the objectives of integration between different application domains as shown in Figure 4. The description of this technical mission shall include the identification of the associated assets for which the mission is defined and the application domains involved.

The method for describing the information exchange profiles is dependent upon the context established according to intra- or inter-domain information exchanges. The capability profiles of the resources to support the information exchange shall be described by the AIME.

NOTE The information exchanges between the allocated resource and definition resources can be described with a sequence diagram according to ISO 18435-2:2012, 5.2.

Application domain categories are defined in ISO 18435-1 as shown in Figure 4. In this part of ISO 18435, interoperability templates are described for integration requirements as depicted in ISO 18435-1 for the interoperability of applications.

As an illustration of the methodology using interoperability templates, the diagnostic and control application domains are used as shown in [Figure 4](#).

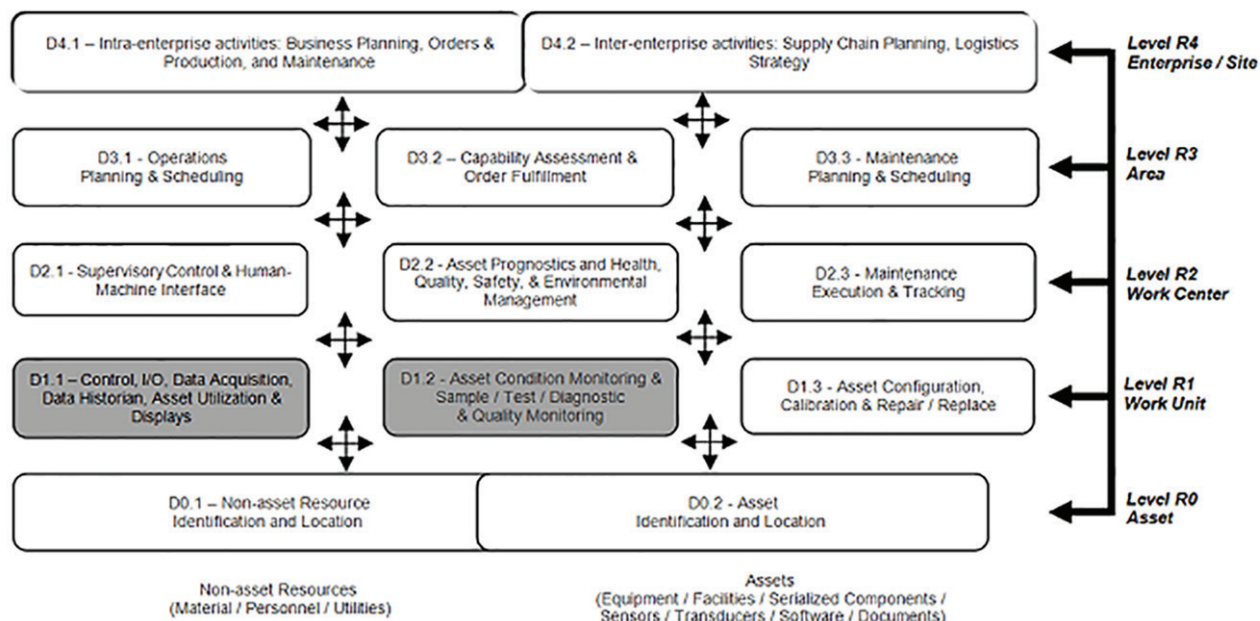

Figure 4 — Categories of application domains

5.1.2 Inter-domain requirements

Interoperability templates for inter-domain application interoperability shall require references to either a specific domain standard or the profile of a specific domain standard, according to ISO 15745, to specify the context of the integration model.

EXAMPLE 1 As shown in [Figure 5](#), the application in the control application domain could use the IEC 61512 reference model to describe the model construction, terms, and definition used in the interoperability templates for the ADME. The application in the diagnostic application domain could use the ISO 13374-2 reference model to describe the corresponding diagnostic ADME.

Thus, when exchanging information between different domains, it is necessary to indicate the context and then to describe the content information handled by the conveyance mechanism. The context, conveyance and content information are contained in the ADME using profile specifications. The actual contents of the information exchange shall be defined by profile specifications.

EXAMPLE 2 An ISO 13374 diagnostic information message, advisory generation, is sent from the diagnostic application as an event to the IEC 61512 batch control application.

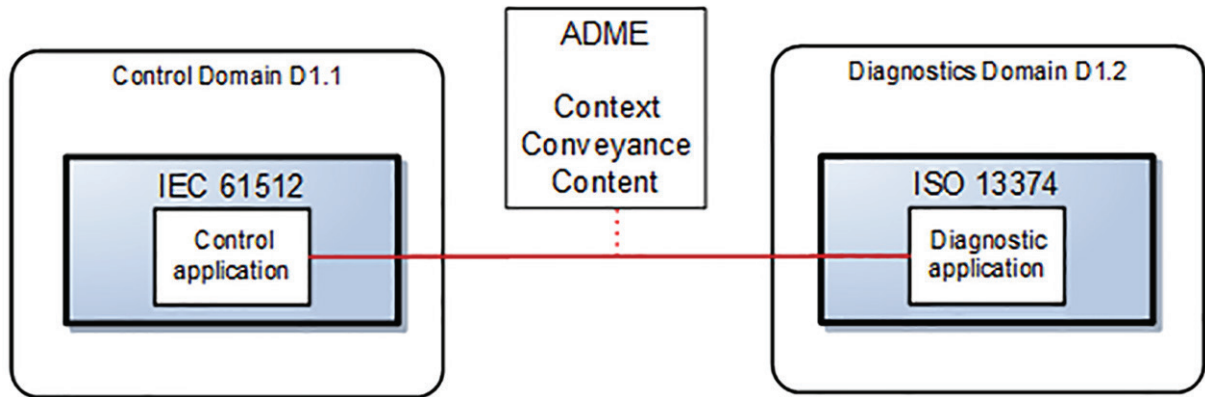

Figure 5 — Inter-domain applications interoperability

The terms and definitions of the information models shall reference standards. The terminology and models of the standards shall be identified and referenced using open technical dictionary (OTD) concepts. In this part of ISO 18435, the information models and terminology use concepts of an open technical dictionary as defined in ISO/TS 29002 (see [Annex A](#)). The use of a common set of models and terms for applications in different domains establishes the basis for enabling information exchange.

This applications integration methodology enables the mapping of the inter-domain interoperability requirements into the AIMs for each application of interest and the ADMEs between applications.

5.1.3 Intra-domain requirements

Intra-domain application interoperability templates shall use a common context for the applications information exchange reference model.

EXAMPLE As shown in [Figure 6](#), the control applications and the diagnostic applications have the same context for the information exchange such that the representation, terms, definitions have the same structure and meaning. The conveyance and the content sections follow the syntax and semantics of IEC 61512.

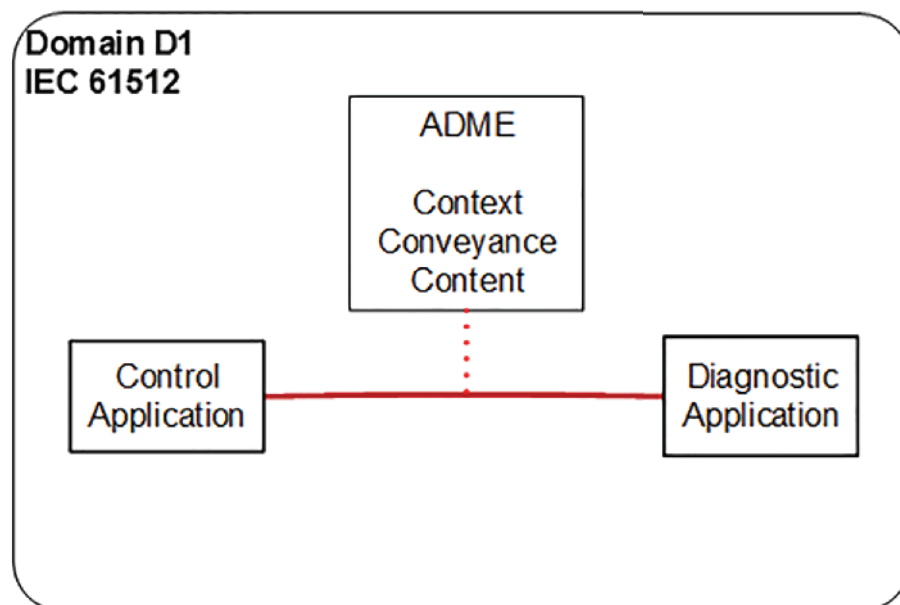

Figure 6 — Intra-domain applications interoperability

5.2 Profiling concept

5.2.1 General

The general profiling concept is depicted in [Figure 7](#). In ISO 18435-2, the general templates for context, conveyance, and contents are specified. The template information for intra-domain information exchange profiles is the information directly from the reference domain standards. For the inter-domain profiles, the open technical dictionaries (OTDs) will need to be referenced to ensure compatibility of terms and definitions for the information exchange information. The OTDs shall contain profiling information for the referenced domains using the methodology of ISO 15745-1; the inter-domain information exchange may require mapping concepts from two technical dictionaries.

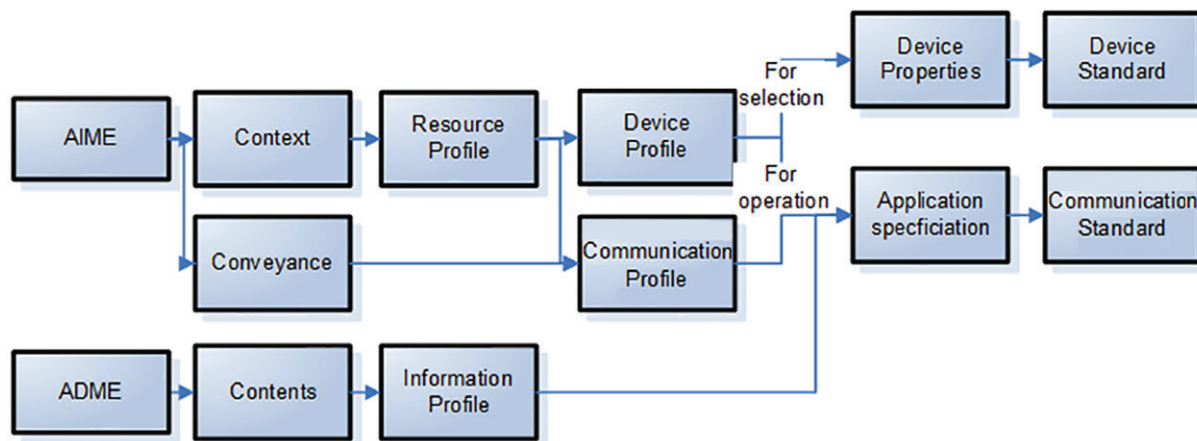

Figure 7 — Profile aggregation

The AIME defines the capability profile to support the information exchange requirements of the ADME. The capability profiles for intra-domain applications are by definition compatible. For instance the device profile and communication profiles conform to a common set of specifications.

Devices can be selected and their relevant properties can be identified and referenced by using component data dictionary such as IEC 61360 [Common Data Dictionary (CDD)]. Device class identification codes and property identification codes can be used to refer to generic components characteristics.

NOTE Descriptions of switchgear and controlgear classes are given by IEC 62683 and descriptions of process equipment are given by IEC 61987.

The capability profiles for inter-domain applications can conform to different device and communications profiles. The application information exchange profile defines the preferred context and conveyance profiles to support the information exchange. The capability profiles defined in the AIMEs shall be checked to verify compatibility. Since the context is specified as a profile referencing a profile, multiple levels of profile checking are required.

5.2.2 Intra-domain information exchange compatibility

The intra-domain information exchange shall use the same context and conveyance profiles as shown in [Figure 8](#). For intra-domain information exchange, this reduces the complexity in the selection process for resource profiles.

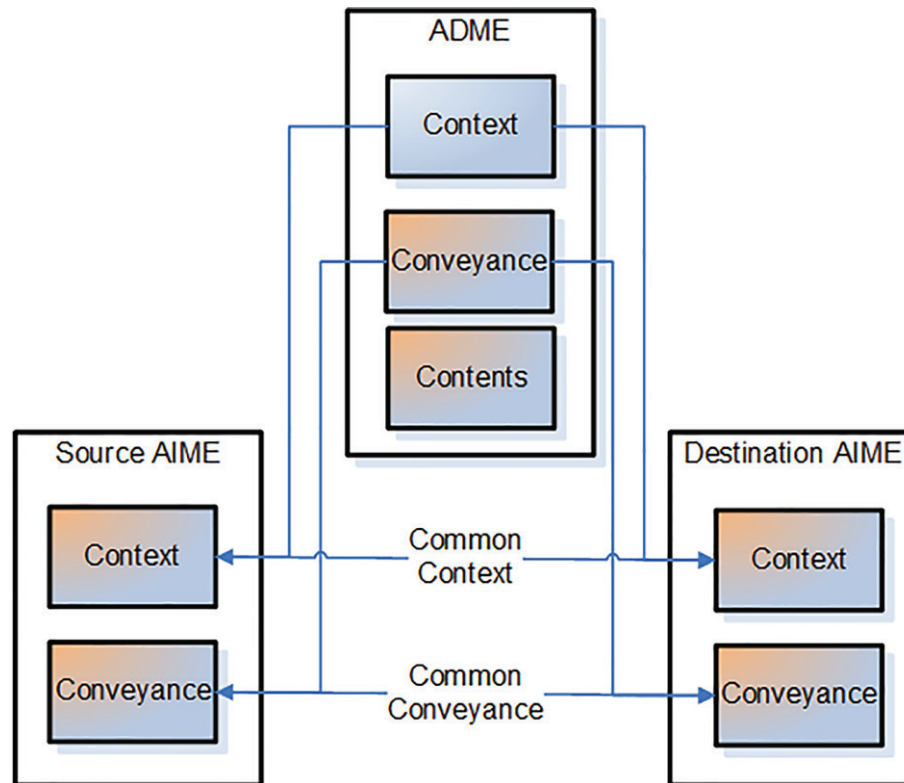

Figure 8 — Intra-domain information exchange

5.2.3 Inter-domain information exchange compatibility

The inter-domain information exchange requires additional compatibility checking to select the appropriate resource profiles for the information exchange. The contexts shall be distinguished by referencing the domains according to ISO 18435-1. The context shall reference a set of definitions specified by an open technical dictionary. If the contexts use different open technical dictionaries, the selection of the appropriate entries from each open technical dictionary shall be identified and a common context established.

The selected resources in each domain shall be checked to provide the conveyance required by the ADME as shown in [Figure 9](#). Each resource (e.g. device, communications, equipment, software) shall provide the requisite capabilities defined by the conveyance specification.

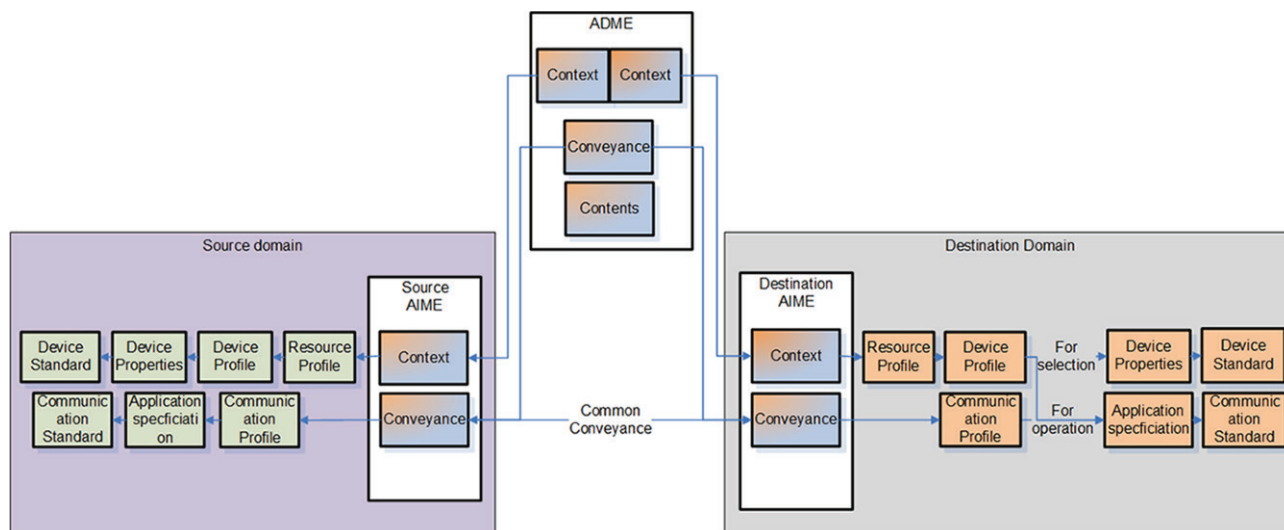

Figure 9 — Inter-domain exchange

5.3 Basic interoperability requirements for information exchange

The information to be exchanged shall be:

- Defined according to an open technical dictionary
- All information shall use concepts defined in an open technical dictionary. The open technical dictionary shall meet the requirements of ISO/TS 29002.

NOTE 1 ISO/TS 29002 provides a basic set of requirements for open technical dictionaries. By use of ISO/TS 29002, a mapping of different contexts is possible.

- Associated with a context by referencing the application domain integration diagram.

EXAMPLE Categories of domains are shown in [Figure 4](#).

- Based on a publicly available information model

NOTE 2 The information may be profiled using the information model; i.e. the characteristic data in the information exchange may be referenced to a publically available standard.

NOTE 3 The information model should indicate the purpose and use of the information exchange, such as whether the information exchange is for design, operational, and/or maintenance purposes.

- Based on ISO 8000 data quality standards; the relevant parts shall be specified.

NOTE 4 The information to be exchanged has a formal specification with a syntax that can be checked by a computer to verify that it meets the master data specification.

NOTE 5 ISO 8000-120 provides requirements for data provenance and provenance record; i.e. the history of the data and information about the owner of the information (e.g. traceable for time and location). The traceability can be realized by using the conveyance section of the ADME.

5.4 Procedure for the construction of AIMEs and ADMEs

5.4.1 General

The general concept and a procedure for construction of AIMEs and ADMEs is shown in the example of [Figure 10](#). The order of the tasks is only shown for illustration.

EXAMPLE 1 A procedure for the construction of AIMEs and ADMEs is shown in [Figure 10](#) below.

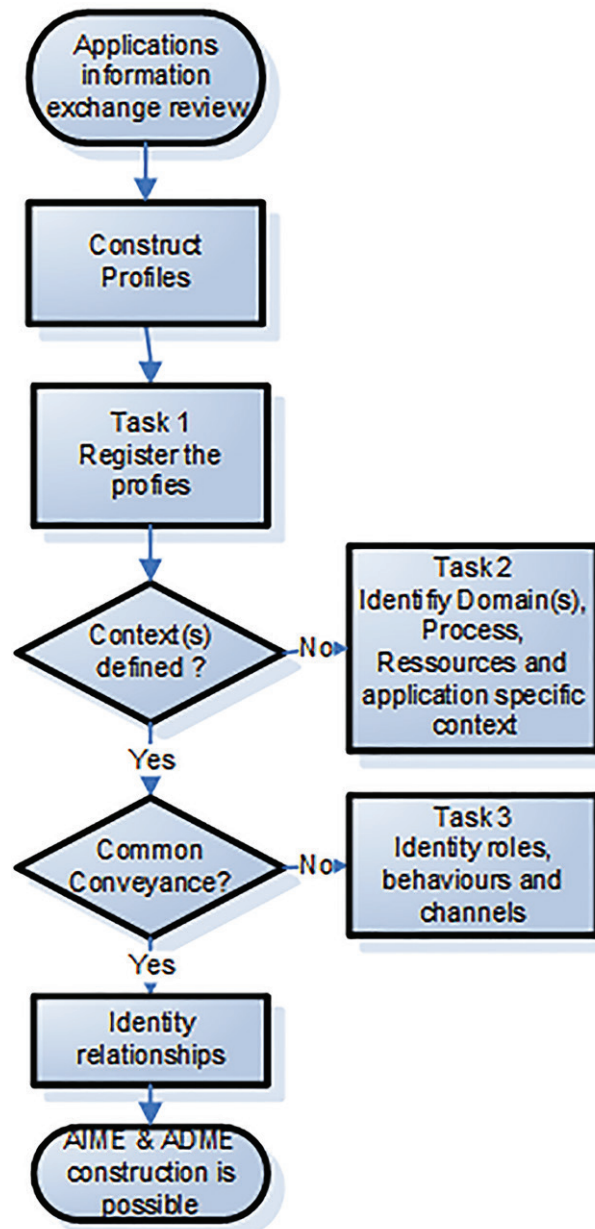

Figure 10 — Procedure example

The procedure shall perform the following steps:

- Determine the application interoperability requirements for the information exchange
- Specify content section for information exchange using common information model
- Specify resource capabilities and conveyance sections using the rules of the selected application integration framework.
- Define the identifiers for the AIMEs and ADMEs references as specified in [Annex A](#).

NOTE The conveyance mechanism between the source and destination application must utilise the same communication service; e.g. when those applications have a common information model of the content but not for the conveyance, then one application needs to be adapted to send information.

EXAMPLE 2 When the conveyance is described in WSDL and uses web service, then the source application will need to develop the necessary set of capabilities to serve the destination requirements. Alternatively the supplier can propose to exchange the information using a “fieldbus” standard. The conveyance mechanism would be one of the fieldbus services.

5.4.2 Application interoperability requirements

5.4.2.1 General

The minimum criteria for interoperability are given in ISO 18435-1:2009, 5.3.

The requirements for interoperability within a common context are defined with respect to customer/supplier perspective or needs, e.g. using a particular field bus standard (IEC 61784), a particular device model (ISO 15745-3), a particular application standards (IEC 61512), or using a particular interface (ISO 13374-2). The aim is to use a common set of vocabulary already defined.

The interoperability will be enabled by completing the actions described in the following sub-clauses.

5.4.2.2 Identify candidate applications and their domain

The candidate applications shall be identified and shall be assigned to their associated domain(s) in accordance with ISO 18435-1:2009, 5.4. The domain(s) involved within the information exchanges shall be determined.

EXAMPLE Using ISO 18435-2:2012, Annex B, the Robot Monitoring application is assigned to domain category identifier, D1.2, and the Robot Control application is assigned to D1.1.

NOTE The domain category identifier, e.g. D1.2 (see ISO 18435-1:2009, 5.4.8), is used to build the AIME.

5.4.2.3 Identify processes

The AIME process profiles (see ISO 18435-2:2012, 6.2.3) of the candidate applications shall be identified.

EXAMPLE 1 Using ISO 18435-2:2012, Annex B, the Robot Monitoring application is associated with the process RobotConditionMonitoring and the Robot Control application is associated with the process MotionControl.

The AIME common resource profile (see ISO 18435-2:2012, 6.2.3) shall be identified.

EXAMPLE 2 Using ISO 18435-2:2012, Annex B, the Robot Monitoring application is associated with the resource PLC and the Robot Control application is associated resources PLC, servo drive, and vibration monitor.

5.4.2.4 Select/create information models

The terms and definitions of the information models shall reference standards. The use of a common set of models and terms for applications in different domains establishes the basis for enabling information exchange.

EXAMPLE Using ISO 18435-2:2012, Annex B, the Robot Monitoring application is associated with the industry specific standard for condition monitoring standard, ISO 13374.

The terminology and models of the standards shall be identified and referenced using open technical dictionary (OTD) concepts. In this part of ISO 18435, the information models and terminology shall use concepts of an open technical dictionary as defined in ISO/TS 29002 (see [Annex A](#)).

5.4.2.5 Define integration criteria

The application integration framework shall be specified for the information exchange.

NOTE 1 ISO 15745-1 specifies the set of rules and elements that comprise the application integration framework. The set of elements and rules for constructing applications, systems, and components are consistent within the application framework.

EXAMPLE Using ISO 18435-2:2012, Annex B, the MEidentification (e.g. ADME) along with its MESource (ISO) describes the reference application integration framework.

If the information exchange occurs between applications described using different application integration frameworks, a set of rules and elements common to both frameworks shall be established.

NOTE 2 The development of a common set of rules for both frameworks is outside the scope of this part of ISO 18435.

5.4.3 Specify content section

The ADME contents for the information exchange shall be specified using a common information model.

EXAMPLE 1 Using ISO 18435-2:2012, Annex B, the content section describes the information exchange name, variables in the exchange, and interactions for the information exchange.

EXAMPLE 2 [Annexes C](#) and [D](#) depict examples using contents for domain category identifier, D1.1 to D1.2, exchange.

5.4.4 Specify resource and conveyance requirements

Based on the application requirements and the resource capabilities, the context and conveyance sections shall be specified using the selected application integration framework.

The AIME resource section specifies the resource profile that provides the capabilities needed for the application.

EXAMPLE 1 Using ISO 18435-2:2012, Annex B, the resource section profiles the resources necessary to support the information exchange, such as a PLC.

The AIME conveyance section specifies the particular communications requirements needed for the application. The common informationType shall be identified in both AIMEs. The set of channelType,roleType and participantType shall be identified in accordance with ISO 18435-2:2012, 6.2.4.

EXAMPLE 2 Using ISO 18435-2:2012, Annex B, the conveyance section profiles the channel type that is supported by the particular application integration framework.

NOTE 1 The conveyance section can profile different channel types that are supported by a particular application integration framework. If the application integration framework supports multiple channel types, the informationType will have the common semantics across the channelType(s).

NOTE 2 The roleType identifies services for the resource (e.g., service description in WSDL)

5.5 AIME requirements

5.5.1 General

AIMEs are constructed according to the resource requirements established by the application interoperability requirements. In diagnostic applications where equipment/device/software is involved in the application, a series of steps are required before operational information exchanges can take place.

5.5.2 AIME detailed requirements

The AIME shall support the following aspects:

- Selection: The first step is to select the appropriate equipment/devices/software profiles to support the information exchange. The equipment/device/software profiles are chosen to meet the requirements established by the resource and conveyance requirements stated in [5.4.4](#). Typical supported applications require selection of the appropriate profiles to support the information exchange.

EXAMPLE 1 [Annex D](#) depicts an example of equipment/device profile for construction of an AIME that meets the requirements of [5.4.4](#).

EXAMPLE 2 ISO 16100 describes manufacturing software capability profiles.

- Configuration: This step specifies the configuration parameters of the device/equipment/software to meet the information exchange requirements. A specific set of configuration steps are required according to the conveyance and context requirements established in [5.4.4](#).
- Operation: This step specifies operational scenarios of the information exchanges between the applications. The operational scenarios define the informationType and the interactions to be supported for the interoperability of the applications. The variable type definition is established by the particular technical dictionary.

EXAMPLE 3 [Annex B](#) depicts an example of operational information to be exchanged that meets the requirements of [5.4.4](#).

[Annex A](#) depicts the requirements for specification of variable type and instance definitions.

5.6 Construction of the ADME

5.6.1 General

ADMEs are constructed using the AIMEs to describe the relationships between the applications.

Any manufacturing resource shall have a unique identification using a standardized method, such as in ISO/TS 29002.

When the complete ADME and the complete AIME's are defined in accordance with ISO 18435-2, and meet the criteria in ISO 18435-1:2009, 5.3, then the applications shall be considered interoperable.

5.6.2 Technical dictionary selection

The technical dictionary used in the application shall be selected and specified in the contents of the ADME.

EXAMPLE [Annex A](#) depicts an example of selection of the technical dictionary in the ADME contents section.

5.6.3 Application framework selection

The application framework used in the application shall be selected and specified in the contents of the ADME.

EXAMPLE [Annex A](#) depicts an example of selection of the application framework in the ADME contents section.

5.6.4 Contents section

Each item shall be described according to [Clause A.6](#).

6 Compliance

An application can state compliance to this part of ISO 18435 by documentation of context, conveyance, and contents templates specified in ISO 18435-2 and compliance with the requirements as stated in this part.

NOTE This part provides guidance for using the templates defined in ISO 18435-2 with the concepts of an open technical dictionary as shown in [Annex A](#).

Annex A (normative)

Ontology in AIME/ADME

A.1 General concepts for OTD

A number of terms are defined in ISO 18435-2. The definition of these terms can be entered into an open technical dictionary (OTD). The use of an OTD enables concept identifiers to be associated with the terms. Since for a particular domain, a different set of terms may be preferred, as long as the concepts are the same, a mapping between the domains is possible. A particular set of terms and their use in a domain may be referred to ontology for that domain. The use of an “identification guide” provides a mapping between the OTD and the particular domain ontology.

NOTE ISO/TS 22745-30 describes methods for construction of identification guides (or data requirements). ISO/TS 22745-40 describes methods for construction of catalogues. The requirements can be specified for the domain ontology; the particular application specifies (via a catalogue description), the support of the particular data requirements.

The terms defined in ISO 18435-2 are defined in [Tables A.2](#) to [A.5](#). Each term can be mapped into an OTD according to ISO/TS 29002-5.

A.2 Format of concept identifier according to ISO/TS 29002-5

The concept identifiers shall be as specified in ISO/TS 29002-5:2009, Clause 7; reference information is shown in [Table A.1](#).

A.2.1 Overview

[Figure A.1](#) summarizes the identifier format.

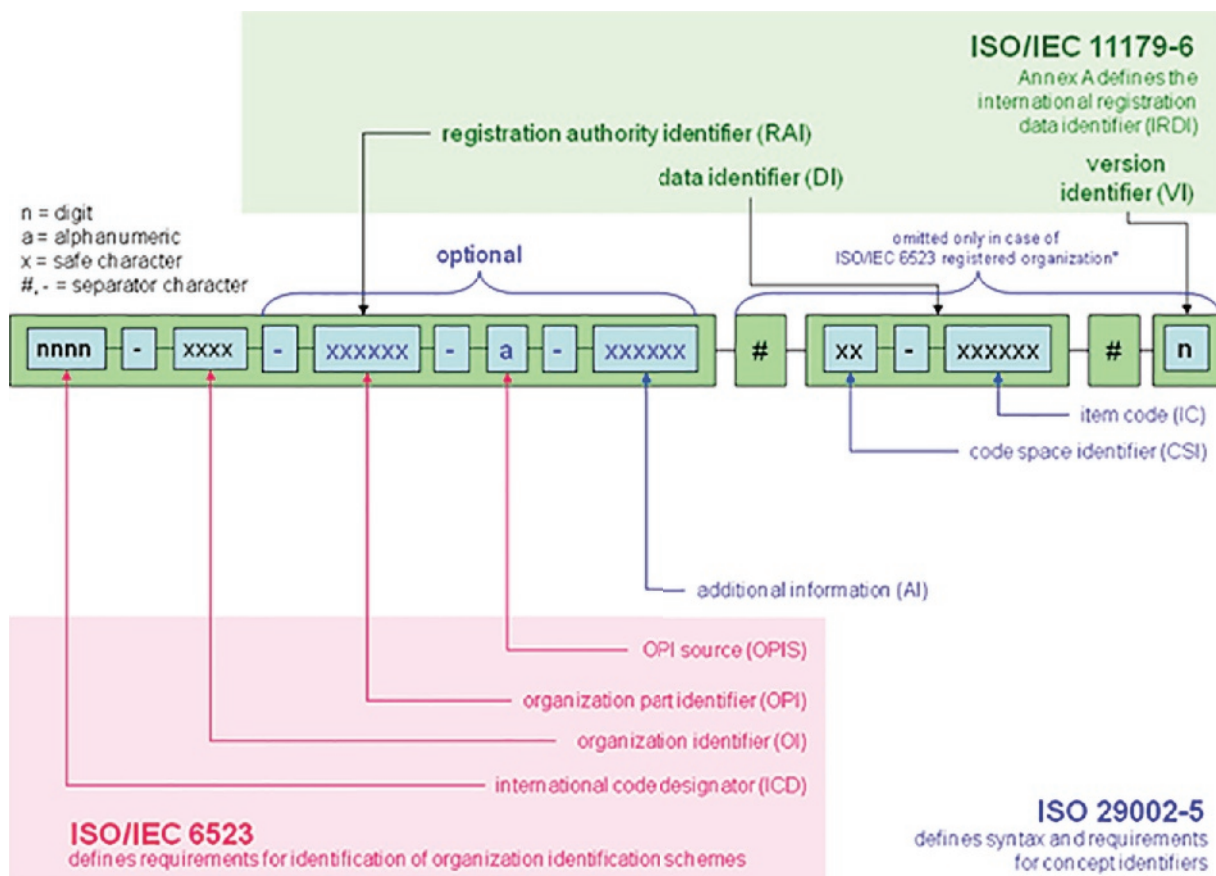

Figure A.1 — Identifier format

A.2.2 Character set

An identifier shall use only the characters listed in [Table A.1](#).

Table A.1 — Character set

Designation	ISO/IEC 10646 code (hexadecimal)	Description
digits	0030 – 0039	'0' – '9'
upper case letters	0041 – 005A	'A' – 'Z'
hyphen	002D	'-
pound sign	0023	'#'
Period	002E	'.'
Colon	003A	':'
Underscore	005F	'_'

In this part of ISO 18435, the term “upper case alphanumeric” refers to an upper case letter or digit.

In this part of ISO 18435, the term “safe character” refers to an upper case letter, a digit, a colon, a period, or an underscore.

A.2.3 Minimum length of attributes

Unless otherwise specified, the minimum length of each attribute specified in this part of ISO 18435 is 1.

A.2.4 Maximum length of identifier

The maximum length of an identifier is 290 characters.

Identifier elements are as specified in ISO/TS 29002-5:2009, Clause 8.

Syntax is as specified in ISO/TS 29002-5:2009, Clause 9.

An IRDI string for a normal identifier shall consist of the RAI string, the DI string, and the VI string, separated by pound sign characters (#).

An RAI string shall consist of the ICD, OI, OPI, OPIS and AI strings, separated by hyphen characters (-). The OPI, OPIS, and AI are optional. If the OPI, OPIS and AI are omitted, the last three hyphens shall be omitted. If the OPIS and AI are omitted, the last two hyphens shall be omitted. If the AI is omitted, the last hyphen shall be omitted.

EXAMPLE The following are some correct and incorrect RAIs.

Correct: RAI = "0123-45-678-9-abc"

ICD = "0123", OI = "45", OPI = "678", OPIS = "9", AI = "abc"

Correct: RAI = "0161-1"

ICD = "0161", OI = "1", OPI = (null), OPIS = (null), AI = (null)

Incorrect: RAI = "0161-1---"

Trailing hyphens are not allowed.

Correct: RAI = "0112-1-18435-AAA001"

ICD = "0112", OI = "1", OPI = (null), OPIS = (null), AI = "18435_3"

The concept types, as defined in ISO/TS 29002-5:2009, Clause 6, are:

Class, property, datatype, document, and ontology.

A.3 Header section

The AIME and ADME header sections are defined by the following set of terms as shown in [Table A.2](#).

Table A.2 — Header section

Term	ICID Term Identifier (OTD=0112-1-18435)		Definition	Example	Variable ICID Identifier ISO/IEC 11578	Concept Type Text 1	Remarks
	Identifier	Mandatory – M Optional - O					
MEidentification	AAA001	M	Identification of AIME/ADME	SmartPumpControlAIME	M	P	ICID reference technical dictionary identifier
MErevision	AAA002	M	Revision of AIME/ADME	1a	M	P	
MEname	AAA003	M	Name of AIME/ADME	D.1.2.Ay_D.1.1Az	M	P	ADID category descriptive name
MEsource	AAA004	M	Source of AIME/ADME	ISO	M	P	
MEclassID	AAA005	M	Identification of AIME/ADME class	AIP	M	C	Profile identification (ISO 15745 example)
MEdate	AAA006	M	Release date of AIME/ADME	2012-12-30	M	P	
MEregistry	AAA007	M	Registry name of AIME/ADME	Industry_specific_registry_name_ISO_13774	M	P	Industry standard registry name – registered in the ICID dictionary
Text 1 C=class, P=property, DT=datatype, D=document. O=Ontology							

A.4 “Context” ontology

The AIME and ADME context sections are defined by the following set of terms as shown in [Table A.3](#).

Table A.3 — Context section

Term	ICID Term Identifier (OTD=0112-1-18435)		Definition	Example	Variable ICID Identifier ISO/IEC 11578	Concept Type Text 1	Remarks
	Identifier	Mandatory – M Optional - O					
domainSourceHandle	AAB001	M	Source domain ID for this AIME from ADID	D1.1	M	C	Domain for Control, I/O, operational data historian, and panel display
domainDestinationHandle	AAB002	M	Destination domain ID for this AIME from ADID	D1.2	M	C	Domain for Asset utilization, condition monitoring, and quality monitoring
applicationSourceHandle	AAB003	M	ID of the source application for the information exchange	PumpControl	M	C	
Text 1 C=class, P=property, DT=datatype, D=document. O=Ontology							

Table A.3 (continued)

Term	ICID Term Identifier (OTD=0112-1-18435)		Definition	Example	Variable ICID Identifier ISO/IEC 11578	Concept Type Text 1	Remarks
	Identifier	Mandatory - M Optional - O					
applicationDestinationHandle	AAB004	M	ID of the destination application for the information exchange	PumpDiagnostics	M	C	
applicationRelationshipSection	AAB005	O	List of contexts for the application		M	C	
applicationDomainRelationshipName	AAB006	O	Specification for the domain specific context of the application	Pump_Control_Context, Pump_Diagnostics_Context	M	C	List of the names
processSourceHandle	AAB007	O	ID for the source process associated with	FlowPIDControl	O	C	A process consists of a set of activities. Each activity is associated with a set of functions. Functions are implemented through a set of resources.
processDestinationHandle	AAB008	O	ID for the destination process associated with	CurrentHealthEvaluation	O	C	
resourcePack	AAB009	O	List of resources involved in information exchange	PLC, MMD	O	C	Each resource in the list has corresponding ISO 15745 compliant resource profile
resourceName	AAB010	O	Instance name of resources	PLC02 MMD00	O	C	
resourceProfile	AAB011	M	Resource profile information	PLCiso15745profile MMDiso15745profile	M	C	
Text 1 C=class, P=property, DT=datatype, D=document. O=Ontology							

A.5 “Conveyance” ontology

The AIME and ADME conveyance are defined by the following set of terms as shown in [Table A.4](#) and the example of use of the ontologies for information exchange between domains.

Table A.4 — Conveyance section

Term	ICID Term Identifier (OTD=0112-1-18435)		Definition	Example	Variable ICID Identifier ISO/IEC 11578	Concept Type Text 1	Remarks
	Identifier	Mandatory - M Optional - O					
informationType	AAC001	M	Types of information exchanged	CavInfoRequestType	0	C	Information type definitions
roleType	AAC002	O	Enumeration of capabilities exhibited by the participant for a particular information exchange	PumpDiagnosticsRole PumpControlRole	0	C	Role type definitions
behaviour	AAC003	O	Behaviour for the specified role type	PumpCavitationDetection PumpControl	0	C	
relationshipType	AAC004	O	Identifies the application role types and behaviour	PumpControl2PumpDiagnostics	0	C	
participationType	AAC005	O	Types of collaborating parties for information exchange	PumpFlowControl CavitationDetection	0	C	
channelType	AAC006	O	Point of information item exchange between participants	PumpControl2PumpMonitor	0	C	describes communication links between role-Types

Text 1 C=class, P=property, DT=datatype, D=document. O=Ontology

A.6 “Contents” ontology

The ADME contents are defined by the following set of terms as shown in [Table A.5](#).

Table A.5 — Contents section

Term	ICID Term Identifier (OTD=0112-1-18435)		Definition	Example	Variable ICID Identifier ISO/IEC 11578	Concept Type Text 1	Remarks
	Identifier	Mandatory – M Optional - O					
informationExchange	AAD001	M	Information E x c h a n g e Name	smartPumpInfor- mationExchange	M	C	
relationship	AAD002	O	Relationship type	t n s : P u m p C o n - trol2PumpDiagnostics	O	C	
variable	AAD003	O	Definitions of individual var- iables used in information exchange	PumpCtrl2CavDete- ctionC CavInfoRequest CavInfoResponse	O	C	Channel name
interaction	AAD004	O	realization of an informa- tion exchange between roles	CavInfoElicitation	O	C	
participate	AAD005	O	Defines the relationships for the inter- action	t n s : P u m p C o n - trol2PumpDiagnostics	O	C	Description of relationship name, source role type and destination role type
exchange	AAD006	O	basic unit of informa- t i o n e x c h a n g e interaction	CavInfoRequestEx	O	C	
send/receive	AAD007	O	send/receive informa- tion per action defined in e x c h a n g e using variables	CavInfoRequest	O	C	

Text 1 C=class, P=property, DT=datatype, D=document. O=Ontology

Annex B (informative)

Smart Pump Information exchange example

B.1 Strategy of diagnostic

For improving an existing process, a new pump diagnostic application should be added to an existing pump control application. The specification of the diagnostic application can be developed based on the relevant diagnostic measures resulting from the assessment of the process according to [Figure B.1](#).

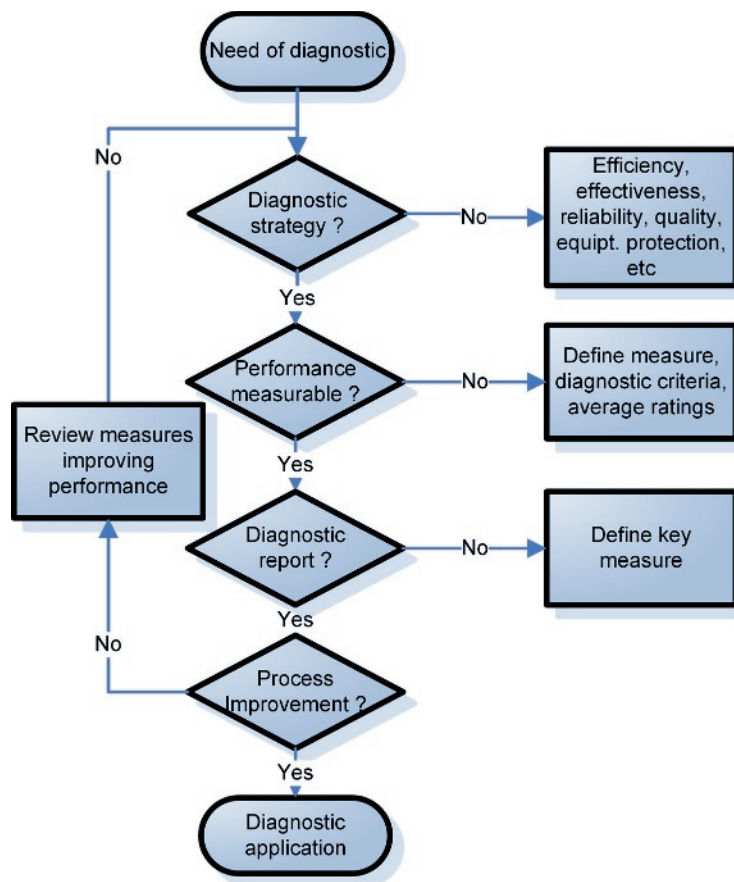

Figure B.1 — Diagnostic strategy

B.2 Example of diagnostic integration into a pump application

The sequence diagram in [Figure B.2](#) shows the simple request/response interaction between Pump Control application and Pump Diagnostics application. ADME supports the information exchange between the applications based upon the resource capabilities identified in the AIME from each application. In this scenario, Pump Control application requests the diagnostics information from Pump Diagnostics application. Later, Pump Control application could adjust the pump operation profile accordingly, which is not included in the information exchange example in this annex.

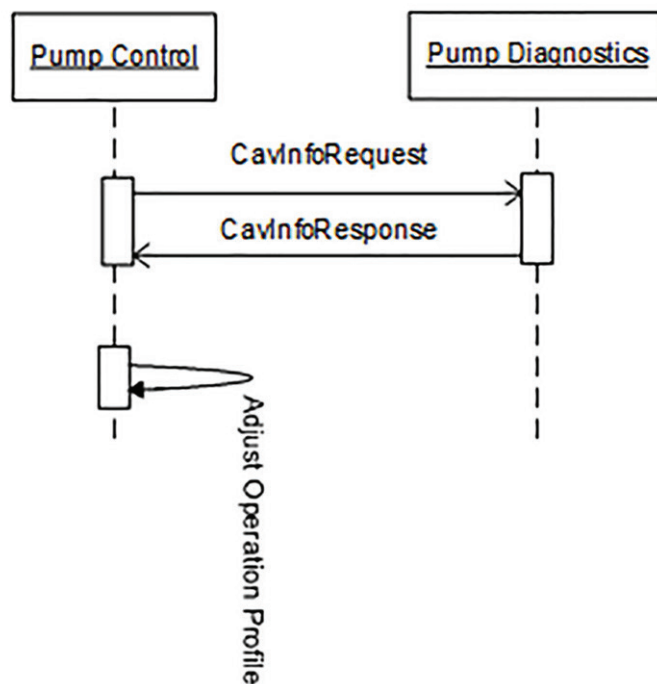

Figure B.2 — Simple information exchange between applications

[Clauses B.3](#) and [B.4](#) show the example set of AIMEs for Pump Control resource and Pump Diagnostics resource. [Clause B.5](#) shows the example ADME for the integrated Smart Pump application. [Clause B.6](#) shows the example web service description for the information exchange.

B.3 AIME for Pump Control

This example represents the AIME for Pump Control.

```

<?xml version="1.0" encoding="utf-8"?>
<ISO_AIME xmlns="http://www.iso.org/aime" xmlns:xsd="http://www.w3.org/2001/XMLSchema-
instance">
  <MatrixElementHeader>
    <MEidentification>SmartPumpControlAIME</MEidentification>
    <MErevision>1a</MErevision>
    <MEname>D.1.2.Ay_D.1.1Az</MEname>
    <MEsource>ISO</MEsource>
    <MEclassID>AIP</MEclassID>
    <MEdate>2013-12-30</MEdate>
    <MEregistry>Industry_specific_registry_name_ISO_13774</MEregistry> </
MatrixElementHeader>
  <MatrixElementBody>
    <Context_Section>
      <domainSection>
        <domainSourceHandle>D1.1</domainSourceHandle>
        <domainDestinationHandle>
        </domainDestinationHandle>
      </domainSection>
      <applicationSection>
        <applicationSourceHandle>PumpControl</applicationSourceHandle>
        <applicationDestinationHandle>
        </applicationDestinationHandle>
      </applicationSection>
      <applicationRelationshipSection>
        <applicationDomainRelationshipName>
          Pump_Control_Context
  
```

```

        </applicationDomainRelationshipName>
    </applicationRelationshipSection>
    <processSection>
        <processSourceHandle>FlowPIDControl</processSourceHandle>
        <processDestinationHandle>
        </processDestinationHandle>
    </processSection>
    <resourceSection>
        <resourcePack name="PLC">
            <resourceName>PLC02</resourceName>
            <resourceProfile>PLCisol15745profile</resourceProfile>
        </resourcePack>
        <resourcePack name="VFD">
            <resourceName>VFD00</resourceName>
            <resourceProfile>VFDisol15745profile</resourceProfile>
        </resourcePack>
    </resourceSection>
</Context_Section>
<Conveyance_Section>
    <description>PumpControl to Diagnostics (Cavitation Detection) Example</
description>
    <informationType name="CavInfoRequestType" type="tCavInfoRequest">
        <description>
            Diagnostics Request Message - AIME XML schema type
            CavInfoRequestMsg will have sensor values for flow, pressure and
temperature
        </description>
    </informationType>
    <informationType name="CavInfoResponseType" type="tCavInfoResponse">
        <description>
            Diagnostics Response Message - AIME XML schema type
            CavInfoResponseMsg will have degree of cavitation
        </description>
    </informationType>
    <roleType name="PumpControlRole">
        <description>Role for Pump Control</description>
        <behaviour name="PumpControl" interface="PumpControlInterface">
description>
            <description>Behaviour for PumpControl - use CIP for VFD control</
            </behaviour>
        </roleType>
    <participantType name="PumpFlowControl">
        <description>Pump Control Participant</description>
        <roleType typeRef="tns:PumpControlRole" />
    </participantType>
    <channelType name="PumpControl2PumpMonitor" type="ISO15745_ENet_CommNet_
Profile">
        <description>
            Pump Control to Diagnostics Channel Type
            Ethernet/IP channel based on ISO15745-2 Comm Profile
        </description>
    </channelType>
</Conveyance_Section>
</MatrixElementBody>
</ISO_AIME>

```

B.4 AIME for Pump Diagnostic

This example represents the AIME for Pump Diagnostics.

```

<?xml version="1.0" encoding="utf-8"?>
<ISO_AIME xmlns="http://www.iso.org/aime" xmlns:xsd="http://www.w3.org/2001/XMLSchema-
instance">
    <MatrixElementHeader>
        <MEidentification>SmartPumpMonitorAIME</MEidentification>
        <MErevision>1a</MErevision>
        <MEname>D.1.2.Ay_D.1.1Az</MEname>
        <MEsource>ISO</MEsource>
        <MEclassID>AIP</MEclassID>
        <MEdate>2013-12-30</MEdate>
    </MatrixElementHeader>

```

```

    <MEregistry>Industry_specific_registry_name_ISO_13774_DM</MEregistry>    </
MatrixElementHeader>
    <MatrixElementBody>
        <Context_Section>
            <domainSection>
                <domainSourceHandle></domainSourceHandle>
                <domainDestinationHandle>D1.2</domainDestinationHandle>
            </domainSection>
            <applicationSection>
                <applicationSourceHandle></applicationSourceHandle>
                <applicationDestinationHandle>PumpDiagnostics</
applicationDestinationHandle>
            </applicationSection>
            <applicationRelationshipSection>
                <applicationDomainRelationshipName>
                    Pump_Diagnostics_Context
                </applicationDomainRelationshipName>
            </applicationRelationshipSection>
            <processSection>
                <processSourceHandle></processSourceHandle>
                <processDestinationHandle>CurrentHealthEvaluation</
processDestinationHandle>
            </processSection>
            <resourceSection>
                <resourcePack name="PLC">
                    <resourceName>PLC01</resourceName>
                    <resourceProfile>PLCisol15745profile</resourceProfile>
                </resourcePack>
            </resourceSection>
        </Context_Section>
        <Conveyance_Section>
            <description>PumpControl to Diagnostics (Cavitation Detection) Example</
description>
            <informationType name="CavInfoRequestType" type="tCavInfoRequest">
                <description>
                    Diagnostics Request Message - AIME XML schema type
                    CavInfoRequestMsg will have sensor values for flow, pressure and
                    temperature
                </description>
            </informationType>
            <informationType name="CavInfoResponseType" type="tCavInfoResponse">
                <description>
                    Diagnostics Response Message - AIME XML schema type
                    CavInfoResponseMsg will have degree of cavitation
                </description>
            </informationType>
            <roleType name="PumpDiagnosticsRole">
                <description>Role for Diagnostics - Cavitation Detection</description>
                <behaviour name="PumpCavitationDetection"
interface="PumpMonitorInterface">
                    <description>Behaviour for Diagnostics Role - Cavitation Detection</
description>
                </behaviour>
            </roleType>
            <participantType name="CavitationDetection">
                <description>Diagnostics Participant</description>
                <roleType typeRef="tns:PumpDiagnosticsRole" />
            </participantType>
            <channelType name="PumpControl2PumpMonitor" type="ISO15745_ENet_CommNet_
Profile">
                <description>Pump Control to Diagnostics Channel Type
                    Ethernet/IP channel based on ISO15745-2 Comm Profile
                </description>
            </channelType>
        </Conveyance_Section>
    </MatrixElementBody>
</ISO_AIME>

```

B.5 ADME for Integrated Smart Pump

This example represents the integrated smart pump application which consists of Pump Control application and Pump Diagnostics application.

```
<?xml version="1.0" encoding="utf-8"?>
<ISO_ADME xmlns="http://www.iso.org/adme" xmlns:xsd="http://www.w3.org/2001/XMLSchema-
instance">
  <MatrixElementHeader>
    <MEidentification>SmartPumpOPCADME</MEidentification>
    <MErevision>1a</MErevision>
    <MENAME>D.1.2.Ay_D.1.1Az</MENAME>
    <MESource>ISO</MESource>
    <MEclassID>AIP</MEclassID>
    <MEdate>2013-12-30</MEdate>
    <MEregistry>Industry_specific_registry_name_ISO_13774_DM_SD</MEregistry>    </
MatrixElementHeader>
  <MatrixElementBody>
    <Context_Section>
      <domainSection>
        <domainSourceHandle>D1.1</domainSourceHandle>
        <domainDestinationHandle>D1.2</domainDestinationHandle>
      </domainSection>
      <applicationSection>
        <applicationSourceHandle>PumpControl</applicationSourceHandle>
        <applicationDestinationHandle>PumpDiagnostics</
applicationDestinationHandle>
      </applicationSection>
      <applicationRelationshipSection>
        <applicationDomainRelationshipName>
          Pump_Control_Context
        </applicationDomainRelationshipName>
        <applicationDomainRelationshipName>
          Pump_Diagnostics_Context
        </applicationDomainRelationshipName>
      </applicationRelationshipSection>
      <processSection>
        <processSourceHandle>FlowPIDControl</processSourceHandle>
        <processDestinationHandle>CurrentHealthEvaluation</
processDestinationHandle>
      </processSection>
      <resourceSection>
        <resourcePack name="PLC">
          <resourceName>PLC02</resourceName>
          <resourceProfile>PLCiso15745profile</resourceProfile>
        </resourcePack>
        <resourcePack name="MMD">
          <resourceName>MMD00</resourceName>
          <resourceProfile>MMDiso15745profile</resourceProfile>
        </resourcePack>
        <resourcePack name="PLC">
          <resourceName>PLC01</resourceName>
          <resourceProfile>PLCiso15745profile</resourceProfile>
        </resourcePack>
      </resourceSection>
    </Context_Section>
    <Conveyance_Section>
      <description>PumpControl to Diagnostics (Cavitation Detection) Example</
description>
      <informationType name="CavInfoRequestType" type="tns:tCavInfoRequest">
        <description>
          Diagnostics Request Message - AIME XML schema type
          CavInfoRequestMsg will have sensor values for flow, pressure and
          temperature
        </description>
      </informationType>
      <informationType name="CavInfoResponseType" type="tns:tCavInfoResponse">
        <description>
          Diagnostics Response Message - AIME XML schema type
          CavInfoResponseMsg will have degree of cavitation
        </description>
      </informationType>
    </Conveyance_Section>
  </MatrixElementBody>
</ISO_ADME>
```



```

        </description>
    </informationType>
    <roleType name="PumpDiagnosticsRole">
        <description>Role for Diagnostics - Cavitation Detection</description>
        <behaviour name="PumpCavitationDetection"
interface="PumpMonitorInterface">
            <description>
                Behaviour for Diagnostics Role - Cavitation Detection
                DiagCIPInterface is based on ISO15745-2 Comm Profile
            </description>
        </behaviour>
    </roleType>
    <roleType name="PumpControlRole">
        <description>Role for Pump Control</description>
        <behaviour name="PumpControl" interface="PumpControlInterface">
            <description>
                Behaviour for PumpControl - use CIP for VFD control
                PumpCtrlCIPInterface is based on ISO15745-2 Comm Profile
            </description>
        </behaviour>
    </roleType>
    <relationshipType name="PumpControl2PumpDiagnostics">
        <description>Pump Control to Cavitation Detection Relationship</
description>
        <roleType typeRef="tns:PumpControlRole" />
        <roleType typeRef="tns:PumpDiagnosticsRole" />
    </relationshipType>
    <participantType name="PumpFlowControl">
        <description>Pump Control Participant</description>
        <roleType typeRef="tns:PumpControlRole" />
    </participantType>
    <participantType name="CavitationDetection">
        <description>Diagnostics Participant</description>
        <roleType typeRef="tns:PumpDiagnosticsRole" />
    </participantType>
    <channelType name="PumpControl2PumpMonitor" type="ISO15745_ENet_CommNet_
Profile">
        <description>
            Pump Control to Diagnostics Channel Type
            Ethernet/IP channel based on ISO15745-2 Comm Profile
        </description>
    </channelType>
</Conveyance_Section>
<Content_Section>
    <informationExchange name="smartPumpInformationExchange">
        <description>Smart Pump Information Exchange</description>
        <relationship type="tns:PumpControl2PumpDiagnostics" />
        <variableDefinitions>
            <variable name="PumpCtrl2CavDetectionC"
channelType="tns:PumpControl2PumpMonitor"
                roleTypes="tns:PumpControlRoletns:PumpDiagnosticsRole">
                <description>Channel Variable</description>
            </variable>
            <variable name="CavInfoRequest"
informationType="tns:CavInfoRequestType"
                roleTypes="tns:PumpControlRoletns:PumpDiagnosticsRole">
                <description>Cavitation Information Request Message</description>
            </variable>
            <variable name="CavInfoResponse"
informationType="tns:CavInfoResponseType"
                roleTypes="tns:PumpCtrlRoletns:PumpDiagnositcsRole">
                <description>Cavitation Information Response Message</description>
            </variable>
        </variableDefinitions>
        <interaction name="CavInfoElicitation" operation="getCavitationInfo"
channelVariable="tns:PumpCtrl2CavDetectionC">
            <description>Cavitation Information Elicitation
                (This could be mapped to WSDL operation or topic in
Publish/Subscribe)
            </description>
        </participate relationshipType="tns:PumpControl2PumpDiagnostics"

```

```

        fromRoleTypeRef="tns:PumpControlRole"
toRoleTypeRef="tns:PumpDiagnosticsRole"
    />
    <exchange name="CavInfoRequestEx"
informationType="tns:CavInfoRequestType"
    action="request">
    <description>Cavitation Detection Request Message Exchange</
description>
        <send variable="CavInfoRequest" />
        <receive variable="CavInfoRequest" />
    </exchange>
    <exchange name="CavInfoResponseEx"
informationType="tns:CavInfoResponseType"
    action="respond">
    <description>Cavitation Detection Response Message Exchange</
description>
        <send variable="CavInfoResponse" />
        <receive variable="CavInfoResponse" />
    </exchange>
    </interaction>
    </informationExchange>
    </Content_Section>
    </MatrixElementBody>
</ISO_ADME>

```

B.6 Web Service Description for the Information Exchange

This example represents the web service description of the information exchange for Pump Diagnostics providing pump monitoring service.

```

<?xml version="1.0" encoding="utf-8" ?>
<description
    xmlns="http://www.w3.org/ns/wsd1"
    targetNamespace= "http://www.iso.org/2011/wsd1/pumpMonitorSvc"
    xmlns:tns= "http://www.iso.org/2011/wsd1/pumpMonitorSvc"
    xmlns:rms = "http://www.iso.org/2011/schemas/pumpMonitorSvc"
    xmlns:wssoap= "http://www.w3.org/ns/wsd1/soap"
    xmlns:soap="http://www.w3.org/2003/05/soap-envelope"
    xmlns:wsd1x= "http://www.w3.org/ns/wsd1-extensions">
    <documentation>
        This document describes the sample pump monitor service
    </documentation>

    <types>
        <xs:schema
            xmlns:xs="http://www.w3.org/2001/XMLSchema"
            targetNamespace="http://www.iso.org/2011/schemas/pumpMonitorSvc"
            xmlns="http://www.iso.org/2011/schemas/pumpMonitorSvc">

            <xs:element name="CavInfoRequest" type="CavInfoRequestType"/>
            <xs:complexType name="CavInfoRequestType">
                <xs:sequence>
                    <xs:element name="pumpType" type="xs:string"/>
                    <xs:element name="pumpLocation" type="xs:string"/>
                    <xs:element name="checkTime" type="xs:time"/>
                </xs:sequence>
            </xs:complexType>

            <xs:element name="CavInfoResponse" type="CavInfoResponseType"/>
            <xs:complexType name="CavInfoResponseType">
                <xs:sequence>
                    <xs:element name="pumpType" type="xs:string"/>
                    <xs:element name="cavitationDegree" type="xs:integer"/>
                </xs:sequence>
            </xs:complexType>
        </xs:schema>
    </types>

    <interface name = "pumpMonitorInterface" >
        <operation name="getCavitationInfo"

```

```
        pattern="http://www.w3.org/ns/wsd1/in-out"
        style="http://www.w3.org/ns/wsd1/style/iri"
        wsdlx:safe = "true">
    <input messageLabel="In"
        element="rms:CavInfoRequest" />
    <output messageLabel="Out"
        element="rms:CavInfoResponse" />
    </operation>
</interface>
<binding name="pumpMonitorSOAPBinding"
    interface="tns:pumpMonitorInterface"
    type="http://www.w3.org/ns/wsd1/soap"
    wsoap:protocol="http://www.w3.org/2003/05/soap/bindings/HTTP/">
    <operation ref="tns:opVibInfoRequest"
        wsoap:mep="http://www.w3.org/2003/05/soap/mep/soap-response"/>
</binding>
<service name="pumpMonitorService"
    interface="tns:pumpMonitorInterface">
    <endpoint name="pumpMonitorEndpoint"
        binding="tns:pumpMonitorSOAPBinding"
        address = "http://www.iso.org/2011/pumpMonitorService"/>
</service>
</description>
```

Annex C (informative)

Jam detection example

Motor current greater than the motor's nameplate rating can indicate a high overload or stall condition, such as an overloaded conveyor or jammed gear. These conditions can result in overheating of the motor, and equipment damage. [Clauses C.1](#) and [C.2](#) show the example set of AIMEs for Pump Control resource and Pump Diagnostics resource. The example AIME in [Clause C.1](#) represents the pump control capability. The example AIME in [Clause C.2](#) represents the jam detection capability. [Clause C.3](#) shows the example ADME for exchanging jam detection information between two applications using EtherNet/IP. [Figure C.1](#) illustrates jam detection information exchange.

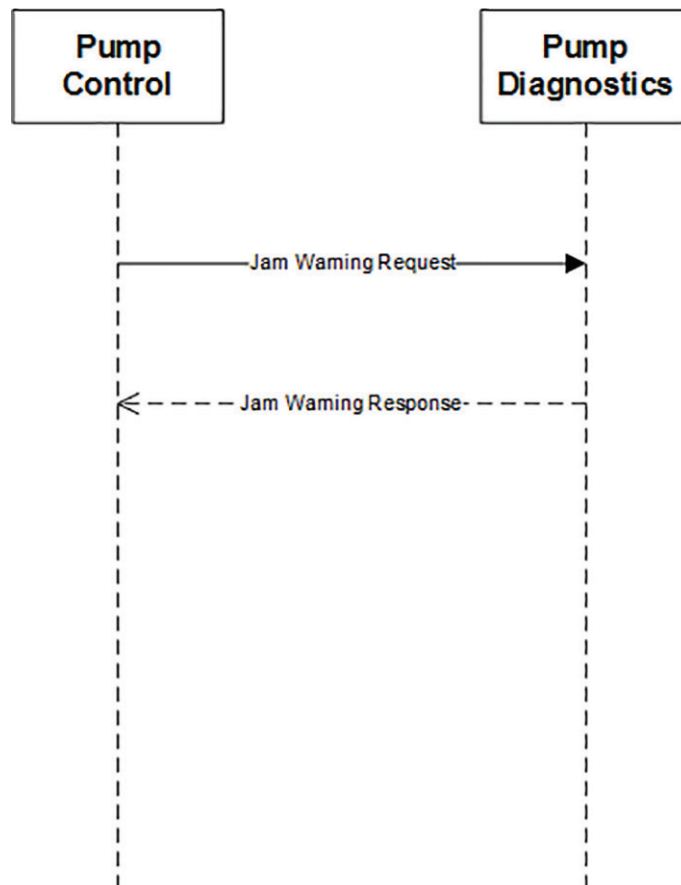

Figure C.1 — Jam detection information exchange

C.1 AIME for Pump Control

This example represents the AIME for Pump Control.

```
<?xml version="1.0" encoding="utf-8"?>
<ISO_AIME xmlns="http://www.iso.org/aime" xmlns:xsd="http://www.w3.org/2001/XMLSchema-
instance">
  <MatrixElementHeader>
    <MEidentification>SmartPumpControlAIME</MEidentification>
    <MErevision>1a</MErevision>
    <MENAME>D.1.2.Ay_D.1.1Az</MENAME>
```

```

    <MEsource>ISO</MEsource>
    <MEclassID>AIP</MEclassID>
    <MEdate>2013-12-30</MEdate>
    <MEregistry>Industry_specific_registry_name_ISO_13774</MEregistry>
  </MatrixElementHeader>
  <MatrixElementBody>
    <Context_Section>
      <domainSection>
        <domainSourceHandle>D1.1</domainSourceHandle>
        <domainDestinationHandle>
          </domainDestinationHandle>
        </domainSection>
      <applicationSection>
        <applicationSourceHandle>PumpControl</applicationSourceHandle>
        <applicationDestinationHandle>
          </applicationDestinationHandle>
        </applicationSection>
      <applicationRelationshipSection>
        <applicationDomainRelationshipName>
          Pump_Control_Context
        </applicationDomainRelationshipName>
      </applicationRelationshipSection>
      <processSection>
        <processSourceHandle>FlowControl</processSourceHandle>
        <processDestinationHandle>
          </processDestinationHandle>
        </processSection>
      <resourceSection>
        <resourcePack name="PLC">
          <resourceName>PLC02</resourceName>
          <resourceProfile>PLCiso15745profile</resourceProfile>
        </resourcePack>
        <resourcePack name="Contactor">
          <resourceName>I-000</resourceName>
          <resourceProfile>I-0iso15745profile</resourceProfile>
        </resourcePack>
      </resourceSection>
    </Context_Section>
    <Conveyance_Section>
      <description>PumpControl to Diagnostics (Jam Detection) Example</description>
      <informationType name="JamWarnLevelType" type="tJamWarnLevel">
        <description>Jam Warn Level data type</description>
      </informationType>
      <informationType name="WarningStatusType" type="tWarningStatus">
        <description>Warning Status</description>
      </informationType>
      <roleType name="PumpControlRole">
        <description>Role for Pump Control</description>
        <behaviour name="MotorStatus" interface="MotorProtectCIPInterface">
          <description>Behaviour for PumpControl - use CIP for Motor Status</
description>
          </behaviour>
        </roleType>
      <participantType name="MotorProtection">
        <description>Pump Control Participant</description>
        <roleType typeRef="tns:PumpControlRole" />
      </participantType>
      <channelType name="PumpControl2PumpMonitor" type="ISO15745_ENet_CommNet_
Profile">
        <description>
          Pump Control to Diagnostics Channel Type
          Ethernet/IP channel based on ISO15745-2 Comm Profile
        </description>
      </channelType>
    </Conveyance_Section>
  </MatrixElementBody>
</ISO_AIME>

```

C.2 AIME for Pump Monitor

This example represents the AIME for Pump Monitoring.

```
<?xml version="1.0" encoding="utf-8"?>
<ISO_AIME xmlns="http://www.iso.org/aime" xmlns:xsd="http://www.w3.org/2001/XMLSchema-
instance">
  <MatrixElementHeader>
    <MEidentification>SmartPumpMonitorAIME</MEidentification>
    <MErevision>1a</MErevision>
    <MENAME>D.1.2.Ay_D.1.1Az</MENAME>
    <MESource>ISO</MESource>
    <MEclassID>AIP</MEclassID>
    <MEdate>2013-12-30</MEdate>
    <MEregistry>Industry_specific_registry_name_ISO_13774_DM</MEregistry>
  </MatrixElementHeader>
  <MatrixElementBody>
    <Context_Section>
      <domainSection>
        <domainSourceHandle></domainSourceHandle>
        <domainDestinationHandle>D1.2</domainDestinationHandle>
      </domainSection>
      <applicationSection>
        <applicationSourceHandle></applicationSourceHandle>
        <applicationDestinationHandle>PumpDiagnostics</
applicationDestinationHandle>
      </applicationSection>
      <applicationRelationshipSection>
        <applicationDomainRelationshipName>
          Pump_Diagnostics_Context
        </applicationDomainRelationshipName>
      </applicationRelationshipSection>
      <processSection>
        <processSourceHandle></processSourceHandle>
        <processDestinationHandle>CurrentHealthEvaluation</
processDestinationHandle>
      </processSection>
      <resourceSection>
        <resourcePack name="PLC">
          <resourceName>PLC01</resourceName>
          <resourceProfile>PLCiso15745profile</resourceProfile>
        </resourcePack>
        <resourcePack name="MotorManagementDevice">
          <resourceName>OL-R01</resourceName>
          <resourceProfile>OL-REtherNetIPprofile</resourceProfile>
        </resourcePack>
      </resourceSection>
    </Context_Section>
    <Conveyance_Section>
      <description>PumpControl to Diagnostics (Jam Detection) Example</description>
      <informationType name="JamWarnLevelType" type="tJamWarnLevel">
        <description>Jam Warn Level data type</description>
      </informationType>
      <informationType name="WarningStatusType" type="tWarningStatus">
        <description>Warning Status</description>
      </informationType>
      <roleType name="PumpDiagnosticsRole">
        <description>Role for Jam Detection</description>
        <behaviour name="OL-RMotorProtect" interface="MotorProtectCIPInterface">
          <description>Behaviour for Jam Detection</description>
        </behaviour>
      </roleType>
      <participantType name="JamDetection">
        <description>Diagnostics Participant</description>
        <roleType typeRef="tns:PumpDiagnosticsRole" />
      </participantType>
      <channelType name="PumpControl2PumpMonitor" type="ISO15745_ENet_CommNet_
Profile">
        <description>Pump Control to Diagnostics Channel Type
          Ethernet/IP channel based on ISO15745-2 Comm Profile

```

```

        </description>
      </channelType>
    </Conveyance_Section>
  </MatrixElementBody>
</ISO_AIME>

```

C.3 ADME for Jam Detection

This example represents the jam detection information exchange.

```

<?xml version="1.0" encoding="utf-8"?>
<ISO_AIME xmlns="http://www.iso.org/aime" xmlns:xsd="http://www.w3.org/2001/XMLSchema-
instance">
  <MatrixElementHeader>
    <MEidentification>SmartPumpADME</MEidentification>
    <MErevision>1a</MErevision>
    <MENAME>D.1.2.Ay_D.1.1Az</MENAME>
    <MESource>ISO</MESource>
    <MEclassID>AIP</MEclassID>
    <MEdate>2013-12-30</MEdate>
    <MEregistry>Industry_specific_registry_name_ISO_13774_DM_SD</MEregistry>
  </MatrixElementHeader>
  <MatrixElementBody>
    <Context_Section>
      <domainSection>
        <domainSourceHandle>D1.1</domainSourceHandle>
        <domainDestinationHandle>D1.2</domainDestinationHandle>
      </domainSection>
      <applicationSection>
        <applicationSourceHandle>PumpControl</applicationSourceHandle>
        <applicationDestinationHandle>PumpDiagnostics</
applicationDestinationHandle>
      </applicationSection>
      <applicationRelationshipSection>
        <applicationDomainRelationshipName>
          Pump_Control_Context
        </applicationDomainRelationshipName>
        <applicationDomainRelationshipName>
          Pump_Diagnostics_Context
        </applicationDomainRelationshipName>
      </applicationRelationshipSection>
      <processSection>
        <processSourceHandle>FlowControl</processSourceHandle>
        <processDestinationHandle>CurrentHealthEvaluation</
processDestinationHandle>
      </processSection>
      <resourceSection>
        <resourcePack name="PLC">
          <resourceName>PLC02</resourceName>
          <resourceProfile>PLCiso15745profile</resourceProfile>
        </resourcePack>
        <resourcePack name="CONTACTOR">
          <resourceName>I-000</resourceName>
          <resourceProfile>I-0iso15745profile</resourceProfile>
        </resourcePack>
        <resourcePack name="PLC">
          <resourceName>PLC01</resourceName>
          <resourceProfile>PLCiso15745profile</resourceProfile>
        </resourcePack>
        <resourcePack name="MotorManagementDevice">
          <resourceName>OL-R01</resourceName>
          <resourceProfile>OL-REtherNetIPprofile</resourceProfile>
        </resourcePack>
      </resourceSection>
    </Context_Section>
    <Conveyance_Section>
      <description>PumpControl to Diagnostics (Jam Detection) Example</description>
      <informationType name="JamWarnLevelType" type="tJamWarnLevel">
        <description>Jam Warn Level data type</description>
      </informationType>
    </Conveyance_Section>
  </MatrixElementBody>
</ISO_AIME>

```

```

    <informationType name="WarningStatusType" type="tWarningStatus">
      <description>Warning Status</description>
    </informationType>
    <roleType name="PumpControlRole">
      <description>Role for Pump Control</description>
      <behaviour name="MotorStatus" interface="MotorProtectCIPInterface">
        <description>Behaviour for PumpControl - use CIP for Motor
          Status</description>
      </behaviour>
    </roleType>
    <roleType name="PumpDiagnosticsRole">
      <description>Role for Jam Detection</description>
      <behaviour name="OL-RMotorProtect" interface="MotorProtectCIPInterface">
        <description>Behaviour for Jam Detection</description>
      </behaviour>
    </roleType>
    <relationshipType name="PumpControl2PumpDiagnostics">
      <description>Pump Control to Cavitation Detection Relationship</
description>
      <roleType typeRef="tns:PumpControlRole" />
      <roleType typeRef="tns:PumpDiagnosticsRole" />
    </relationshipType>
    <participantType name="MotorProtection">
      <description>Pump Control Participant</description>
      <roleType typeRef="tns:PumpControlRole" />
    </participantType>
    <participantType name="JamDetection">
      <description>Diagnostics Participant</description>
      <roleType typeRef="tns:PumpDiagnosticsRole" />
    </participantType>
    <channelType name="PumpControl2PumpMonitor" type="ISO15745_Enet_CommNet_
Profile">
      <description>
        Pump Control to Diagnostics Channel Type
        Ethernet/IP channel based on ISO15745-2 Comm Profile
      </description>
    </channelType>
  </Conveyance_Section>
  <Content_Section>
    <informationExchange name="JamDetectionInformationExchange">
      <description>Jam Detection Information Exchange</description>
      <relationship type="tns:PumpControl2PumpDiagnostics" />
      <variableDefinitions>
        <variable name="PumpCtrl2JamDetectionC"
channelType="tns:PumpControl2PumpMonitor"
          roleTypes="tns:PumpControlRoletns:PumpDiagnosticsRole">
          <description>Channel Variable</description>
        </variable>
        <variable name="WarningCode" informationType="tns:WarningStatusType"
          roleTypes="tns:PumpControlRoletns:PumpDiagnosticsRole">
          <description>Cavitation Information Request Message</description>
        </variable>
      </variableDefinitions>
      <interaction name="ControlSupervisorObject" operation="GetAttributeSingle"
channelVariable="tns:PumpCtrl2JamDetectionC">
        <participate relationshipType="tns:PumpControl2PumpDiagnostics"
          fromRoleTypeRef="tns:PumpControlRole"
          toRoleTypeRef="tns:PumpDiagnosticsRole" />
        <exchange name="getWarningCode"
informationType="tns:WarningStatusType"
          action="get">
          <description>Get Warning Code</description>
          <send variable="WarningCode" />
          <receive variable="WarningCode" />
        </exchange>
      </interaction>
    </informationExchange>
  </Content_Section>
</MatrixElementBody>
</ISO_ADME>

```

Annex D (informative)

EtherNet/IP to OPC Information Exchange

Clauses D.1 and D.2 show the example set of AIMEs for Pump Control resource and Pump Diagnostics resource. The example AIME in Clause D.1 represents the pump control capability. The example AIME in Clause D.2 represents the jam detection capability. Clause D.3 shows the example ADME for exchanging jam detection information using EtherNet/IP to OPC channel. Figure D.1 illustrates jam detection information exchange through OPC.

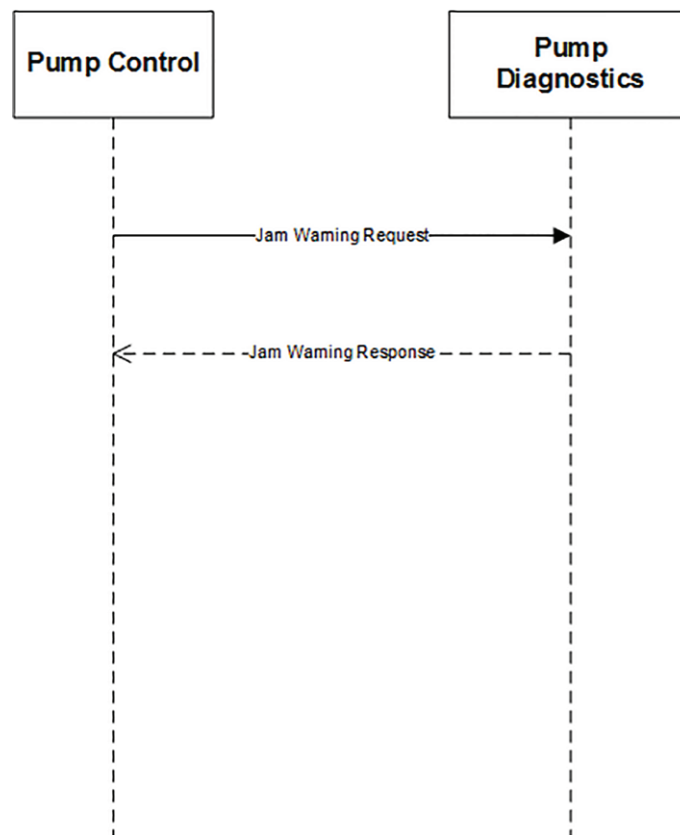

Figure D.1 — Jam detection information exchange through OPC

D.1 AIME for Pump Control

```

<?xml version="1.0" encoding="utf-8"?>
<ISO_AIME xmlns="http://www.iso.org/aime" xmlns:xsd="http://www.w3.org/2001/XMLSchema-
instance">
  <MatrixElementHeader>
    <MEidentification>SmartPumpControlAIME</MEidentification>
    <MErevision>1a</MErevision>
    <MENAME>D.1.2.Ay_D.1.1Az</MENAME>
    <MESource>ISO</MESource>
    <MEclassID>AIP</MEclassID>
    <MEdate>2013-12-30</MEdate>
    <MEregistry>Industry_specific_registry_name_ISO_13774</MEregistry>
  </MatrixElementHeader>
  <MatrixElementBody>
    <Context_Section>
  
```

```

    <domainSection>
      <domainSourceHandle>D1.1</domainSourceHandle>
      <domainDestinationHandle>
      </domainDestinationHandle>
    </domainSection>
    <applicationSection>
      <applicationSourceHandle>PumpControl</applicationSourceHandle>
      <applicationDestinationHandle>
      </applicationDestinationHandle>
    </applicationSection>
    <applicationRelationshipSection>
      <applicationDomainRelationshipName>
        Pump_Control_Context
      </applicationDomainRelationshipName>
    </applicationRelationshipSection>
    <processSection>
      <processSourceHandle>FlowControl</processSourceHandle>
      <processDestinationHandle>
      </processDestinationHandle>
    </processSection>
    <resourceSection>
      <resourcePack name="PLC">
        <resourceName>PLC02</resourceName>
        <resourceProfile>PLCiso15745profile</resourceProfile>
      </resourcePack>
      <resourcePack name="CONTACTOR">
        <resourceName>I-000</resourceName>
        <resourceProfile>I-Oiso15745profile</resourceProfile>
      </resourcePack>
    </resourceSection>
  </Context_Section>
  <Conveyance_Section>
    <description>PumpControl to Diagnostics Example</description>
    <informationType name="WarningCodeType" type="tWarningCode">
      <description>Warning Code Type</description>
    </informationType>
    <roleType name="PumpControlRole">
      <description>Role for Pump Control</description>
      <behaviour name="MotorStatus" interface="MotorProtectCIPInterface">
      </behaviour>
    </roleType>
    <participantType name="MotorProtection">
      <description>Pump Control Participant</description>
      <roleType typeRef="tns:PumpControlRole" />
    </participantType>
    <channelType name="PumpControl2PumpMonitor" type="OPC_2_EtherNetIP_Profile">
      <description>
        Pump Control to Diagnostics Channel Type
      </description>
    </channelType>
  </Conveyance_Section>
</MatrixElementBody>
</ISO_AIME>

```

D.2 AIME for Pump Diagnostics

```

<?xml version="1.0" encoding="utf-8"?>
<ISO_AIME xmlns="http://www.iso.org/aime" xmlns:xsd="http://www.w3.org/2001/XMLSchema-
instance">
  <MatrixElementHeader>
    <MEidentification>SmartPumpMonitorAIME</MEidentification>
    <MErevision>1a</MErevision>
    <MEname>D.1.2.Ay_D.1.1Az</MEname>
    <MEsource>ISO</MEsource>
    <MEclassID>AIP</MEclassID>
    <MEdate>2013-12-30</MEdate>
    <MEregistry>Industry_specific_registry_name_ISO_13774_DM</MEregistry>
  </MatrixElementHeader>
  <MatrixElementBody>
    <Context_Section>
      <domainSection>

```

```

        <domainSourceHandle></domainSourceHandle>
        <domainDestinationHandle>D1.2</domainDestinationHandle>
    </domainSection>
    <applicationSection>
        <applicationSourceHandle></applicationSourceHandle>
        <applicationDestinationHandle>PumpDiagnostics</
applicationDestinationHandle>
    </applicationSection>
    <applicationRelationshipSection>
        <applicationDomainRelationshipName>
            Pump_Diagnostics_Context
        </applicationDomainRelationshipName>
    </applicationRelationshipSection>
    <processSection>
        <processSourceHandle></processSourceHandle>
        <processDestinationHandle>CurrentHealthEvaluation</
processDestinationHandle>
    </processSection>
    <resourceSection>
        <resourcePack name="PLC">
            <resourceName>PLC01</resourceName>
            <resourceProfile>PLCiso15745profile</resourceProfile>
        </resourcePack>
        <resourcePack name="MotorManagementDevice">
            <resourceName>OL-R01</resourceName>
            <resourceProfile>OL-REtherNetIPprofile</resourceProfile>
        </resourcePack>
    </resourceSection>
</Context_Section>
<Conveyance_Section>
    <description>PumpControl to Diagnostics (Jam Detection) Example</description>
    <informationType name="WarningStatusType" type="tWarningStatus">
        <description>Warning Status</description>
    </informationType>
    <roleType name="PumpDiagnosticsRole">
        <description>Role for Jam Detection</description>
        <behaviour name="OL-RMotorProtect" interface="MotorProtectCIPInterface">
            <description>Behaviour for Jam Detection</description>
        </behaviour>
    </roleType>
    <participantType name="JamDetection">
        <description>Diagnostics Participant</description>
        <roleType typeRef="tns:PumpDiagnosticsRole" />
    </participantType>
    <channelType name="PumpControl2PumpMonitor" type="OPC_2_EtherNetIP_Profile">
        <description>
            Pump Control to Diagnostics Channel Type
        </description>
    </channelType>
</Conveyance_Section>
</MatrixElementBody>
</ISO_AIME>

```

D.3 ADME for information exchange using EtherNet/IP to OPC bridge

```

<?xml version="1.0" encoding="utf-8"?>
<ISO_AIME xmlns="http://www.iso.org/aime" xmlns:xsd="http://www.w3.org/2001/XMLSchema-
instance">
    <MatrixElementHeader>
        <MEidentification>SmartPumpADME</MEidentification>
        <MErevision>1a</MErevision>
        <MEname>D.1.2.Ay_D.1.1Az</MEname>
        <MEsource>ISO</MEsource>
        <MEclassID>AIP</MEclassID>
        <MEdate>2013-12-30</MEdate>
        <MEregistry>Industry_specific_registry_name_ISO_13774_DM_SD</MEregistry>
    </MatrixElementHeader>
    <MatrixElementBody>
        <Context_Section>
            <domainSection>
                <domainSourceHandle>D1.1</domainSourceHandle>

```

```

    <domainDestinationHandle>D1.2</domainDestinationHandle>
  </domainSection>
  <applicationSection>
    <applicationSourceHandle>PumpControl</applicationSourceHandle>
    <applicationDestinationHandle>PumpDiagnostics</
applicationDestinationHandle>
  </applicationSection>
  <applicationRelationshipSection>
    <applicationDomainRelationshipName>
      Pump_Control_Context
    </applicationDomainRelationshipName>
    <applicationDomainRelationshipName>
      Pump_Diagnostics_Context
    </applicationDomainRelationshipName>
  </applicationRelationshipSection>
  <processSection>
    <processSourceHandle>FlowControl</processSourceHandle>
    <processDestinationHandle>CurrentHealthEvaluation</
processDestinationHandle>
  </processSection>
  <resourceSection>
    <resourcePack name="PLC">
      <resourceName>PLC02</resourceName>
      <resourceProfile>PLCiso15745profile</resourceProfile>
    </resourcePack>
    <resourcePack name="Contactor">
      <resourceName>I-000</resourceName>
      <resourceProfile>I-Oiso15745profile</resourceProfile>
    </resourcePack>
    <resourcePack name="PLC">
      <resourceName>PLC01</resourceName>
      <resourceProfile>PLCiso15745profile</resourceProfile>
    </resourcePack>
    <resourcePack name="MotorManagementDevice">
      <resourceName>OL-R01</resourceName>
      <resourceProfile>OL-REtherNetIPprofile</resourceProfile>
    </resourcePack>
  </resourceSection>
</Context_Section>
<Conveyance_Section>
  <description>PumpControl to Diagnostics (Jam Detection) Example</description>
  <informationType name="WarningCodeType" type="tWarningCode">
    <description>Warning Code Type</description>
  </informationType>
  <informationType name="WarningStatusType" type="tWarningStatus">
    <description>Warning Status</description>
  </informationType>
  <roleType name="PumpControlRole">
    <description>Role for Pump Control</description>
    <behaviour name="MotorStatus" interface="MotorProtectCIPInterface">
    </behaviour>
  </roleType>
  <roleType name="PumpDiagnosticsRole">
    <description>Role for Jam Detection</description>
    <behaviour name="OL-RMotorProtect" interface="MotorProtectCIPInterface">
      <description>Behaviour for Jam Detection</description>
    </behaviour>
  </roleType>
  <relationshipType name="PumpControl2PumpDiagnostics">
    <description>Pump Control to Cavitation Detection Relationship</
description>
    <roleType typeRef="tns:PumpControlRole" />
    <roleType typeRef="tns:PumpDiagnosticsRole" />
  </relationshipType>
  <participantType name="MotorProtection">
    <description>Pump Control Participant</description>
    <roleType typeRef="tns:PumpControlRole" />
  </participantType>
  <participantType name="JamDetection">
    <description>Diagnostics Participant</description>
    <roleType typeRef="tns:PumpDiagnosticsRole" />
  </participantType>

```

```

    </participantType>
    <channelType name="PumpControl2PumpMonitor" type="OPC_2_EtherNetIP_Profile">
      <description>
        Pump Control to Diagnostics Channel Type
      </description>
    </channelType>
  </Conveyance_Section>
  <Content_Section>
    <informationExchange name="JamDetectionInformationExchange">
      <relationship type="tns:PumpControl2PumpDiagnostics" />
      <variableDefinitions>
        <variable name="PumpHMI2MotorMonitorC"
channelType="tns:PumpControl2PumpMonitor"
          roleTypes="tns:PumpControlRole tns:PumpDiagnosticsRole">
        </variable>
        <variable name="WarningCode" informationType="tns:WarningStatusType"
          roleTypes="tns:PumpControlRoletns:PumpDiagnosticsRole">
        </variable>
        <variable name="OPCServer1:PumpControl1:Motor1:WarningCode"
          informationType="tns:WarningStatusType"
roleTypes="tns:PumpControlRole
          tns:PumpDiagnosticsRole">
        </variable>
      </variableDefinitions>
      <interaction name="ControlSupervisorObject" operation="GetAttributeSingle"
channelVariable="tns:PumpCtrl2JamDetectionC">
        <exchange name="getWarningCode"
informationType="tns:WarningStatusType"
          action="get">
          <description>Get Warning Code using EtherNet/IP</description>
          <send variable="WarningCode" />
          <receive variable="WarningCode" />
        </exchange>
      </interaction>
      <interaction name="PumpStationControl" operation="getMotorStatus"
channelVariable="tns:PumpHMI2MotorMonitorC">
        <participate relationshipType="tns:PumpControl2PumpDiagnostics"
          fromRoleTypeRef="tns:PumpControlRole"
toRoleTypeRef="tns:PumpDiagnosticsRole"
          />
        <exchange name="getWarningCode" informationType="tns:WarningCodeType"
          action="get">
          <description>Get Warning Code using OPC</description>
          <send variable="WarningCode" />
          <receive variable="OPCServer1:PumpControl1:Motor1:WarningCode" />
        </exchange>
      </interaction>
    </informationExchange>
  </Content_Section>
</MatrixElementBody>
</ISO_ADME>

```

Bibliography

- [1] ISO 8000-120, *Data quality – Part 120: Master data: Exchange of characteristic data: Provenance*
- [2] ISO/IEC 10746-2, *Information technology — Open distributed processing — Reference model — Part 2: Foundations*
- [3] ISO/IEC 11179-6, *Information technology – Metadata registries (MDR) – Part 6: Registration*
- [4] ISO/IEC 11578, *Information technology – Open Systems Interconnection – Remote Procedure Call (RPC)*
- [5] ISO 13374 (all parts), *Condition monitoring and diagnostics of machines — Data processing, communication and presentation*
- [6] ISO 13584-511:2006, *Industrial automation systems and integration — Parts library — Part 511: Mechanical systems and components for general use — Reference dictionary for fasteners*
- [7] ISO/IEC 15459, all parts, *Information technology – Item Management – Unique identification of transport units*
- [8] ISO 15745-2, *Industrial automation systems and integration — Open systems application integration framework — Part 2: Reference description for ISO 11898-based control systems*
- [9] ISO 15745-3, *Industrial automation systems and integration — Open systems application integration framework — Part 3: Reference description for IEC 61158-based control systems*
- [10] ISO 16100 (all parts), *Industrial automation systems and integration — Manufacturing software capability profiling for interoperability*
- [11] ISO/TS 22745-30, *Industrial automation systems and integration — Open technical dictionaries and their application to master data — Part 30: Identification guide representation*
- [12] ISO/TS 22745-40, *Industrial automation systems and integration — Open technical dictionaries and their application to master data — Part 40: Master data representation*
- [13] IEC 61360 (all parts), *Standard data element types with associated classification scheme for electric components*
- [14] IEC 61512 (all parts), *Batch control*
- [15] IEC 61784 (all parts), *Industrial communication networks – Profiles*
- [16] IEC 61987 (all parts), *Industrial-process measurement and control – Data structures and elements in process equipment catalogues*
- [17] IEC 62264-2, *Enterprise-control system integration – Part 2: Object and attributes for enterprise-control system integration*
- [18] IEC 62683, *Low-voltage switchgear and controlgear – Product data and properties for information exchange*

British Standards Institution (BSI)

BSI is the national body responsible for preparing British Standards and other standards-related publications, information and services.

BSI is incorporated by Royal Charter. British Standards and other standardization products are published by BSI Standards Limited.

About us

We bring together business, industry, government, consumers, innovators and others to shape their combined experience and expertise into standards-based solutions.

The knowledge embodied in our standards has been carefully assembled in a dependable format and refined through our open consultation process. Organizations of all sizes and across all sectors choose standards to help them achieve their goals.

Information on standards

We can provide you with the knowledge that your organization needs to succeed. Find out more about British Standards by visiting our website at bsigroup.com/standards or contacting our Customer Services team or Knowledge Centre.

Buying standards

You can buy and download PDF versions of BSI publications, including British and adopted European and international standards, through our website at bsigroup.com/shop, where hard copies can also be purchased.

If you need international and foreign standards from other Standards Development Organizations, hard copies can be ordered from our Customer Services team.

Subscriptions

Our range of subscription services are designed to make using standards easier for you. For further information on our subscription products go to bsigroup.com/subscriptions.

With **British Standards Online (BSOL)** you'll have instant access to over 55,000 British and adopted European and international standards from your desktop. It's available 24/7 and is refreshed daily so you'll always be up to date.

You can keep in touch with standards developments and receive substantial discounts on the purchase price of standards, both in single copy and subscription format, by becoming a **BSI Subscribing Member**.

PLUS is an updating service exclusive to BSI Subscribing Members. You will automatically receive the latest hard copy of your standards when they're revised or replaced.

To find out more about becoming a BSI Subscribing Member and the benefits of membership, please visit bsigroup.com/shop.

With a **Multi-User Network Licence (MUNL)** you are able to host standards publications on your intranet. Licences can cover as few or as many users as you wish. With updates supplied as soon as they're available, you can be sure your documentation is current. For further information, email bsmusales@bsigroup.com.

BSI Group Headquarters

389 Chiswick High Road London W4 4AL UK

Revisions

Our British Standards and other publications are updated by amendment or revision.

We continually improve the quality of our products and services to benefit your business. If you find an inaccuracy or ambiguity within a British Standard or other BSI publication please inform the Knowledge Centre.

Copyright

All the data, software and documentation set out in all British Standards and other BSI publications are the property of and copyrighted by BSI, or some person or entity that owns copyright in the information used (such as the international standardization bodies) and has formally licensed such information to BSI for commercial publication and use. Except as permitted under the Copyright, Designs and Patents Act 1988 no extract may be reproduced, stored in a retrieval system or transmitted in any form or by any means – electronic, photocopying, recording or otherwise – without prior written permission from BSI. Details and advice can be obtained from the Copyright & Licensing Department.

Useful Contacts:

Customer Services

Tel: +44 845 086 9001

Email (orders): orders@bsigroup.com

Email (enquiries): cservices@bsigroup.com

Subscriptions

Tel: +44 845 086 9001

Email: subscriptions@bsigroup.com

Knowledge Centre

Tel: +44 20 8996 7004

Email: knowledgecentre@bsigroup.com

Copyright & Licensing

Tel: +44 20 8996 7070

Email: copyright@bsigroup.com



...making excellence a habit.™