

Gas cylinders — Refillable welded stainless steel cylinders —

Part 2: Test pressure greater than 6 MPa

ICS 23.020.30

National foreword

This British Standard was published by BSI. It is the UK implementation of ISO 18172-2:2007.

The UK participation in its preparation was entrusted by Technical Committee PVE/3, Gas containers, to Subcommittee PVE/3/3, Transportable gas containers — Cylinder design, construction and testing at the time of manufacture.

A list of organizations represented on this committee can be obtained on request to its secretary.

This publication does not purport to include all the necessary provisions of a contract. Users are responsible for its correct application.

Compliance with a British Standard cannot confer immunity from legal obligations.

This British Standard was published under the authority of the Standards Policy and Strategy Committee on 31 May 2007

© BSI 2007

ISBN 978 0 580 50784 7

Amendments issued since publication

Amd. No.	Date	Comments

INTERNATIONAL
STANDARD

ISO
18172-2

First edition
2007-03-01

**Gas cylinders — Refillable welded
stainless steel cylinders —**

**Part 2:
Test pressure greater than 6 MPa**

*Bouteilles à gaz — Bouteilles soudées en acier inoxydable
rechargeables —*

Partie 2: Pression d'épreuve supérieure à 6 MPa



Reference number
ISO 18172-2:2007(E)

Contents

Page

Foreword.....	v
Introduction	vi
1 Scope	1
2 Normative references	1
3 Terms, definitions and symbols	2
3.1 Terms and definitions.....	2
3.2 Symbols	3
4 Materials and heat treatment	4
4.1 General.....	4
4.2 Categories	4
4.3 Heat treatment.....	5
4.4 Test requirements.....	5
5 Design	5
5.1 General requirements.....	5
5.2 Calculation of cylindrical shell wall thickness	5
5.3 Design of convex ends.....	6
5.4 Minimum wall thickness.....	9
5.5 Ends of other shapes	9
5.6 Design of openings.....	9
5.7 Bungs.....	9
6 Construction and workmanship	9
6.1 General.....	9
6.2 Welding	10
6.3 Cryoforming procedure.....	10
6.4 Welded joints of pressure-containing parts	11
6.5 Non-pressure-containing attachments.....	11
6.6 Valve protection	11
6.7 Neck threads	11
6.8 Visual examination	11
7 New design tests.....	12
7.1 General requirements.....	12
7.2 Verifications and tests.....	13
7.3 Descriptions of tests	14
7.4 Design testing certificate	15
8 Batch tests.....	15
8.1 General.....	15
8.2 Information	15
8.3 Tensile test	15
8.4 Bend test.....	18
8.5 Impact test.....	20
8.6 Macroscopic examination of weld cross-sections.....	21
8.7 Checks and verifications	21
9 Tests on every cylinder	22
9.1 Pressure test	22
9.2 Hardness test	22
9.3 Leakage test	22
10 Failure to meet test requirements	22

11	Markings	22
12	Certificate	23
Annex A	(normative) Radiographic examination of welds	24
Annex B	(normative) Description and evaluation of manufacturing defects and conditions for rejection of welded stainless steel gas cylinders at time of visual inspection	26
Annex C	(informative) Examples of design and batch testing certificates	28
Bibliography	33

Foreword

ISO (the International Organization for Standardization) is a worldwide federation of national standards bodies (ISO member bodies). The work of preparing International Standards is normally carried out through ISO technical committees. Each member body interested in a subject for which a technical committee has been established has the right to be represented on that committee. International organizations, governmental and non-governmental, in liaison with ISO, also take part in the work. ISO collaborates closely with the International Electrotechnical Commission (IEC) on all matters of electrotechnical standardization.

International Standards are drafted in accordance with the rules given in the ISO/IEC Directives, Part 2.

The main task of technical committees is to prepare International Standards. Draft International Standards adopted by the technical committees are circulated to the member bodies for voting. Publication as an International Standard requires approval by at least 75 % of the member bodies casting a vote.

Attention is drawn to the possibility that some of the elements of this document may be the subject of patent rights. ISO shall not be held responsible for identifying any or all such patent rights.

ISO 18172-2 was prepared by Technical Committee ISO/TC 58, *Gas cylinders*, Subcommittee SC 3, *Cylinder design*.

ISO 18172 consists of the following parts, under the general title *Gas cylinders — Refillable welded stainless steel cylinders*:

- *Part 1: Test pressure 6 MPa and below*
- *Part 2: Test pressure greater than 6 MPa*

Introduction

The purpose of this part of ISO 18172 is to provide a specification for the design, manufacture and testing of refillable, transportable, welded stainless steel gas cylinders with a test pressure above 6 MPa (60 bar).

The specifications given are based on knowledge of, and experience with, materials, design requirements, manufacturing processes and control during manufacture of cylinders in common use.

ISO 18172 has been prepared to address the general requirements in Section 6.2.1 of the UN model regulations for the transportation of dangerous goods ST/SG/AC.10/1/Rev.13. It is intended to be used under a variety of regulatory regimes, but has been written so that it is suitable for use with the conformity assessment system in paragraph 6.2.2.5 of the above-mentioned model regulations.

Gas cylinders — Refillable welded stainless steel cylinders —

Part 2: Test pressure greater than 6 MPa

1 Scope

This part of ISO 18172 specifies minimum requirements concerning material, design, construction and workmanship, manufacturing processes and testing of refillable transportable welded stainless steel gas cylinders, of water capacities from 0,5 l up to and including 150 l, for compressed and liquefied gases. This part of ISO 18172 is applicable only to cylinders manufactured from stainless steels with a maximum tensile strength of less than 1 100 MPa and a test pressure above 6 MPa (60 bar).

2 Normative references

The following referenced documents are indispensable for the application of this document. For dated references, only the edition cited applies. For undated references, the latest edition of the referenced document (including any amendments) applies.

ISO 2504:1973, *Radiography of welds and viewing conditions for films — Utilization of recommended patterns of image quality indicators (I.Q.I.)*

ISO 3651-2, *Determination of resistance to intergranular corrosion of stainless steels — Part 2: Ferritic, austenitic and ferritic-austenitic (duplex) stainless steels — Corrosion test in media containing sulfuric acid*

ISO 5817, *Welding — Fusion-welded joints in steel, nickel, titanium and their alloys (beam welding excluded) — Quality levels for imperfections*

ISO 6506-1, *Metallic materials — Brinell hardness test — Part 1: Test method*

ISO 6892, *Metallic materials — Tensile testing at ambient temperature*

ISO 7438, *Metallic materials — Bend test*

ISO 9328-7:2004, *Steel flat products for pressure purposes — Technical delivery conditions — Part 7: Stainless steels*

ISO 9606-1, *Approval testing of welders — Fusion welding — Part 1: Steels*

ISO 9956-1, *Specification and approval of welding procedures for metallic materials — Part 1: General rules for fusion welding*

ISO 9956-3, *Specification and approval of welding procedures for metallic materials — Part 3: Welding procedure tests for arc welding of steels*

ISO 11114-1, *Transportable gas cylinders — Compatibility of cylinder and valve materials with gas contents — Part 1: Metallic materials*

ISO 11117, *Gas cylinders — Valve protection caps and valve guards — Design, construction and tests*

ISO 13769, *Gas cylinders — Stamp marking*

ISO 14556, *Steel — Charpy V-notch pendulum impact test — Instrumented test method*

ISO 14732, *Welding personnel — Approval testing of welding operators for fusion welding and of resistance weld setters for fully mechanized and automatic welding of metallic materials*

ISO 17636, *Non-destructive testing of welds — Radiographic testing of fusion-welded joints*

ISO 17637, *Non-destructive testing of welds — Visual testing of fusion-welded joints*

ISO 20807, *Non-destructive testing — Qualification of personnel for limited application of non-destructive testing*

3 Terms, definitions and symbols

For the purposes of this document, the following terms, definitions and symbols apply.

3.1 Terms and definitions

3.1.1

yield stress

value corresponding to 0,2 % proof stress ($R_{p0,2}$) or, for austenitic steels in the solution annealed condition, 1 % proof stress ($R_{p1,0}$)

3.1.2

solution annealing

softening heat treatment for austenitic steels in which a cylinder is heated to a uniform temperature above the solid solution temperature, followed by rapid cooling

3.1.3

cryoforming

process where the cylinder is subjected to a controlled low temperature deformation treatment that results in a permanent increase in strength

3.1.4

cold working

plastic deformation treatment given to sheet material at ambient temperature, with the aim of permanently increasing the material strength

3.1.5

cold forming

final deformation treatment at ambient temperature given to the prefabricated cylinder, known as the preform, which results in a permanent increase in the material strength

3.1.6

batch

quantity of cylinders made consecutively by the same manufacturer, using the same manufacturing techniques, to the same design, size and material, from the same cast on the same type of welding machines and welding procedures

3.1.7

design stress factor

F
ratio of equivalent wall stress at test pressure (p_H) to guaranteed minimum yield stress (R_e)

3.2 Symbols

a	calculated minimum thickness, in mm, of the cylindrical shell
a'	guaranteed minimum thickness, in mm, of the cylindrical shell, including any corrosion allowance (see 7.1.1)
a_1	calculated value of a used in the calculation of b (see 5.3.2)
a_m	mean wall thickness, in mm, of the cylindrical shell of the cylinder preform
A	percentage elongation after fracture
b	calculated minimum thickness, in mm, of the cylinder end
b'	guaranteed minimum thickness, in mm, of the cylinder end (see 7.1.1)
C	shape factor of dished ends
D	outside diameter, in mm, of the cylinder (see Figure 1)
D_f	diameter of former, in mm (see 8.4.3 and Figure 10)
D_m	mean diameter of the cylindrical shell of a cylinder preform, in mm
F	design stress factor (see 3.1.7)
f_c	cryoforming factor established by the manufacturer for each batch of cylinders
h	height, in mm, of the cylindrical part of the end (see Figure 1)
H	outside height, in mm, of the domed part of the end (see Figure 1)
J	stress reduction factor
L	length, in mm, of the cylinder
n	ratio of diameter of bend test former (D_f) to the thickness of the test piece (t)
p_b	measured burst pressure, in MPa (bar) ¹⁾ , above atmospheric pressure, in the burst test
p_c	cryoforming or cold forming pressure in MPa (bar), above atmospheric pressure
p_h	hydraulic test pressure, in MPa (bar), above atmospheric pressure
p_y	observed yield pressure, in MPa (bar), above atmospheric pressure
r	inside radius of the knuckle end, in mm (see Figure 1)
R	inside radius of the dished end, in mm (see Figure 1)
R_e	yield stress, in MPa, as defined in 3.1.1 and used for design calculation
R_{ea}	value of the actual yield stress, in MPa, determined by the tensile test

1) 0,1 MPa = 10⁵ Pa = 1 bar

$R_{p0,2}$	minimum value of 0,2 % proof stress, in MPa, guaranteed by the cylinder manufacturer for the finished cylinder, in accordance with ISO 6892 (see Note)
$R_{p1,0}$	minimum value of 1,0 % proof stress, in MPa, guaranteed by the cylinder manufacturer for the finished cylinder, in accordance with ISO 6892 (see Note)
R_g	minimum value of tensile strength, in MPa, guaranteed by the cylinder manufacturer for the finished cylinder
R_m	actual value of tensile strength, in MPa, determined by tensile test (see 8.3)
t	actual thickness of the test specimen, in mm (see Figure 7)

NOTE For cryoformed and cold formed cylinders, the minimum value guaranteed by the manufacturer refers only to the cylindrical part of the finished cylinder.

4 Materials and heat treatment

4.1 General

4.1.1 Materials of shells and end pressings shall be stainless steels in a condition suitable for pressing or drawing and welding, and shall conform to ISO 9328-7.

4.1.2 Grades of steel used for the cylinder manufacture shall be compatible with the intended gas service (e.g. corrosive gases, embrittling gases), in accordance with ISO 11114-1. Due to the scope of this part of ISO 18172, which permits tensile strengths up to 1 100 MPa, particular care shall be taken when designing hydrogen gas cylinders.

4.1.3 There is a risk of sensitization to intergranular corrosion resulting from the hot processing of austenitic and duplex stainless steels. If any heat treatment was done during manufacturing, an intergranular corrosion test in accordance with 7.3.3 shall be carried out.

4.1.4 The manufacturer shall be able to guarantee cylinder steel casting traceability for each pressure-retaining part of the cylinder.

4.1.5 All parts welded to the cylinder shall be made of compatible material with respect to the weldability.

4.1.6 The cylinder manufacturer shall obtain and provide material certificates of the ladle analysis from the steel manufacture of the steel supplied for the construction of the pressure-retaining parts of the cylinder and for the welding consumables.

4.1.7 Some grades of stainless steel may be susceptible to environmental stress corrosion cracking (SCC). A check shall be made of the material standard to ensure that the selection of material is compatible with the intended service. Special precautions shall be taken, e.g. by carrying out a post-processing SCC test or by using a grade of material more resistant to SCC. No special precautions shall compromise any other requirements in this part of ISO 18172.

4.1.8 The welding consumables shall be such that they are capable of giving consistent welds. The strength characteristics of the welds shall not be less than those considered in the design and/or calculations.

4.2 Categories

The following three broad categories of stainless steels are recognised:

- ferritic;
- austenitic;

— ferritic/austenitic (duplex).

The steels used shall be in accordance with ISO 9328-7.

4.3 Heat treatment

4.3.1 For cylinders subjected to cold forming or cryoforming processes, heat treatment of the preform component part is not required. Cryoformed cylinders shall not be subjected to any subsequent heat treatment or to additional heat application, such as welding.

4.3.2 Raw materials used for the manufacture of pressure-retaining parts of the cylinders shall be annealed for ferritic steels, or solution annealed for austenitic and duplex steels (see ISO 9328-7:2004, Annex C).

4.3.3 The cylinder manufacturer shall obtain and provide certificates for the heat treatment of all parts covered by 4.3.2 that are used for the construction of the gas cylinders.

4.3.4 The cylinder manufacturer shall maintain records of any heat treatment carried out.

4.4 Test requirements

The material of the finished cylinders shall satisfy the requirements of Clause 7.

5 Design

5.1 General requirements

5.1.1 The calculation of the wall thickness of the pressure-containing parts shall be related to the yield stress of the parent material.

5.1.2 For calculation purposes, the value of the yield stress R_e is limited to a maximum of $0,85 R_g$.

5.1.3 The internal pressure upon which the calculation of gas cylinders is based shall be the test pressure p_h .

5.1.4 A fully dimensioned drawing of the material, including the specification, shall be produced.

5.2 Calculation of cylindrical shell wall thickness

The wall thickness, a , of the cylindrical shell shall not be less than that calculated using the following formula:

$$a = \frac{D}{2} \left(1 - \sqrt{\frac{10 \cdot F \cdot J \cdot R_e - \sqrt{3} \cdot p_h}{10 \cdot F \cdot J \cdot R_e}} \right) \quad (1)$$

where

$$F = 0,77$$

$$J = 1 \text{ for circumferential welds}$$

$$J = 0,9 \text{ for longitudinal welds.}$$

The minimum wall thickness shall also satisfy the requirements of 5.4.

5.3 Design of convex ends

5.3.1 The shape of ends of gas cylinders shall be such that the following conditions are fulfilled:

— for torispherical shaped ends [see Figure 1 a]): $R \leq D$; $r \geq 0,1 D$; $h \geq 4 b$

— for ellipsoidal shaped ends [see Figure 1 b]): $H \geq 0,192 D$; $h \geq 4 b$

5.3.2 The wall thickness, b , of the ends of gas cylinders shall be not less than that calculated using the formula

$$b = a_1 \times C \quad (2)$$

where

a_1 is the value of a calculated in accordance with 5.2, using $J = 1,0$

C is a shape factor, whose value shall be obtained from the graph given in Figure 2 or Figure 3.

5.3.3 For cryoformed cylinders, convex ends shall be hemispherically shaped. The shape factor C shall be equal to 1.

The minimum 1,0 % proof stress to be achieved in the hemispherical ends shall be equal to

$$R_p = R_{p1,0} \times (a \div 2b) \quad (3)$$

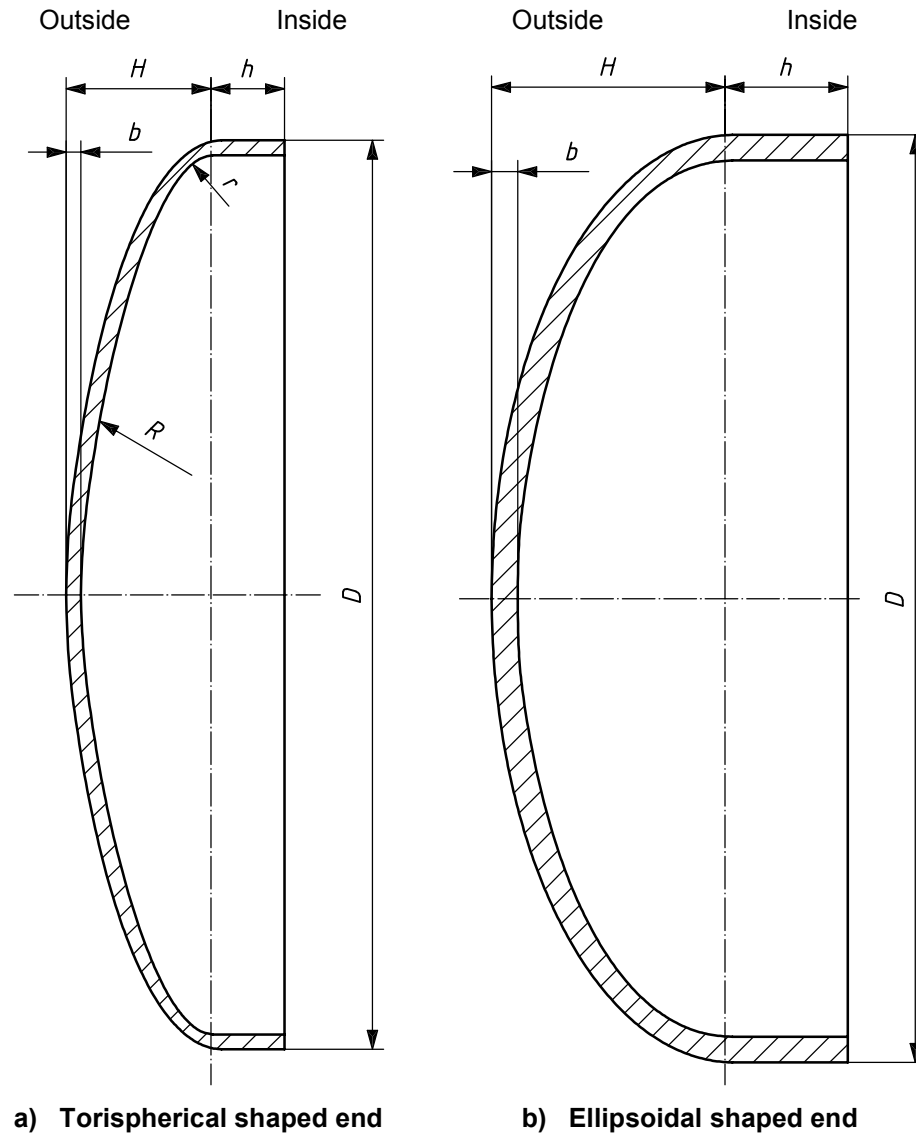

NOTE For torispherical shaped ends, the height H can be calculated using

$$H = (R + b) - \sqrt{\left[\left((R + b) - \frac{D}{2} \right) \cdot \left[(R + b) + \frac{D}{2} - 2(r + b) \right] \right]} \quad (4)$$

Figure 1 — Illustration of cylinder ends

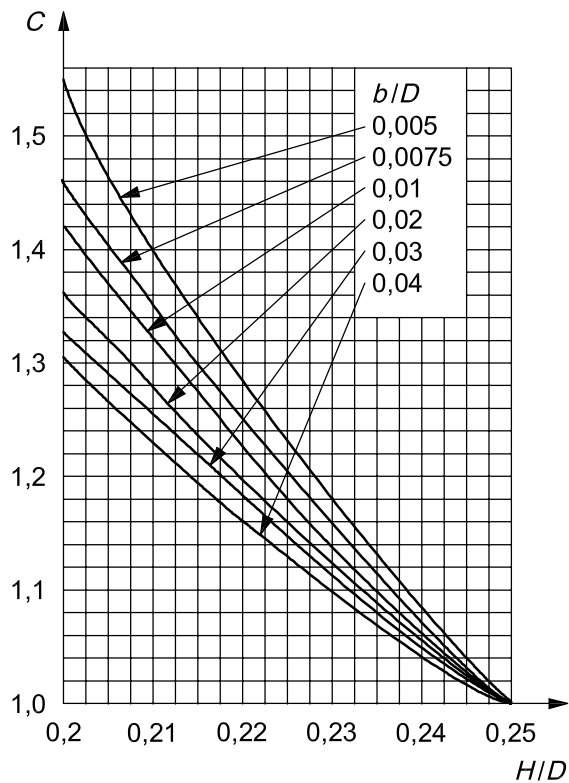

Figure 2 — Values of shape factor C for H/D between 0,2 and 0,25

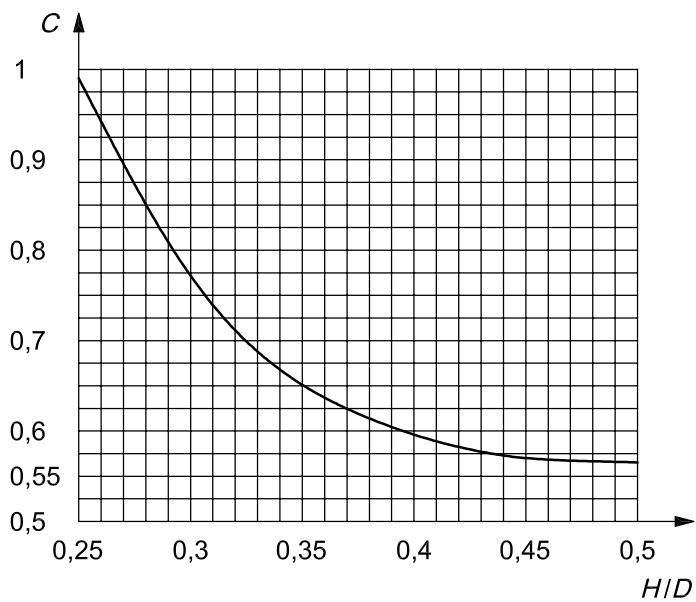

Figure 3 — Values of shape factor C for H/D between 0,25 and 0,5

5.4 Minimum wall thickness

5.4.1 The minimum wall thickness of the cylindrical shell a and of the end b shall be not less than the value derived from the following formulae, as appropriate:

$$\text{for } D \leq 100 \text{ mm: } a = b = 1,1 \text{ mm} \quad (5)$$

$$\text{for } 100 \text{ mm} < D \leq 150 \text{ mm: } a = b = 1,1 + 0,008 (D - 100) \text{ mm} \quad (6)$$

$$\text{for } D > 150 \text{ mm: } a = b = \frac{D}{250} + 0,7 \text{ mm, with an absolute minimum of } 1,5 \text{ mm} \quad (7)$$

These formulae apply to cylindrical shells and ends irrespective of whether they are designed by calculation under 5.2 and 5.3, or by the pressure cycling test described in 7.3.2.

5.4.2 Apart from the requirements of 5.3, 5.4 and 5.5, any cylindrical part integral with an end shall, except as qualified by 5.4.3, also satisfy the requirements given in 5.2 for the cylindrical shell.

5.4.3 Where the length of the cylindrical portion of the gas cylinder, measured between the beginning of the domed parts of the two ends, is not more than $\sqrt{2bD}$, the wall thickness shall be not less than that of the domed part (see 5.3.2).

5.5 Ends of other shapes

Ends of shapes other than those covered by 5.3 may be used, provided that the adequacy of their design is demonstrated by a pressure cycling test in accordance with 7.3.2, or by stress analysis.

5.6 Design of openings

5.6.1 The location of all openings shall be restricted to the end(s) of cylinders.

5.6.2 Each opening in the cylinder shall be reinforced either by a valve boss or pad, of weldable and compatible steel, securely attached by welding and so designed as to be of adequate strength and to result in no harmful stress concentrations. This shall be confirmed by design calculations or a pressure cycling test in accordance with 7.3.2.

5.6.3 The welds of the openings shall be separated from longitudinal and circumferential joints by a distance not less than $3a$.

5.7 Bungs

Bungs shall be designed such that they are welded in position with the shoulder of the bung on the inside of the domed end.

6 Construction and workmanship

6.1 General

The cylinder or cylinder preform shall be produced by using one of the following:

- seamless or longitudinally welded tube with forged or deep drawn ends circumferentially welded,
- longitudinally welded tube with spun ends,
- a seamless tube, followed by hot forming where the base is sealed with added weld metal,

- cold worked tube or plate,
- welded deep drawn parts,
- cold forming or cryoforming of welded cylinder preforms, or
- plate material rolled and formed with longitudinal weld, with forged or deep drawn ends circumferentially welded.

6.2 Welding

6.2.1 General

In view of the thicker walls required for this specification, attention shall be given to the welding processes (see 6.4 and 6.8.2)

6.2.2 Procedures

Before proceeding with the production of a given design of cylinder, each manufacturer shall qualify all welding procedures to ISO 9956-1 and ISO 9956-3, and welders to ISO 14732 and ISO 9606-1. Records of such qualification shall be kept on file by the manufacturer.

6.2.3 Quality

For embrittling gases, e.g. hydrogen, particular care shall be taken during the welding to ensure that all defects conform to ISO 5817 level B. The effects of typical welding defects, e.g. porosity and undercutting, should not be underestimated when dealing with such gases.

6.3 Cryoforming procedure

6.3.1 Cryoforming, as defined in 3.1.3, is a method to increase the mechanical properties of especially metastable austenitic steels by applying a high internal pressure to the vessel preform at cryogenic temperatures.

The relevant process parameters are the cryoforming pressure p_c and the cryoforming temperature.

The design of the finished cylinder shall be in accordance with Clause 5.

6.3.2 The cryoforming operation shall be carried out at a cryoforming pressure p_c , which shall be calculated according to

$$p_c = \frac{f_c \times R_{p1,0} \times 20 \times a_m}{D_m} \quad (8)$$

f_c depends on the cryoforming temperature, the cast analysis for each batch of cylinders and the yield strength to be achieved, and shall be established by the manufacturer such that the finished cylinders satisfy the requirements as specified in Clauses 5 and 8. Between batches of one design of cylinder (as defined in 3.1.6), f_c shall not vary by more than $\pm 10\%$.

6.3.3 For each cryoformed cylinder, the manufacturer shall record a pressure-time diagram of the cryoforming process, where the rate of pressure increase, the achieved cryoform pressure and the holding time are shown. The rate of pressure increase shall not be more, and the holding time shall not be less, than that established during the design testing for the cylinder.

6.3.4 The maximum permanent deformation of the vessel's perimeter due to the cryoforming shall be no more than 15%. Measurement may be carried out by using a tape measure, for example.

6.3.5 The cryoforming temperature shall remain constant during the process (e.g. by submerging the cylinder preform in a suitable cryogenic liquid) and shall be established during the design test.

6.4 Welded joints of pressure-containing parts

6.4.1 The longitudinal joint, of which there shall be not more than one, shall be butt-welded.

6.4.2 Circumferential joints, of which there shall be no more than two in the cylindrical part, shall be butt-welded in all cases for cryoformed cylinders, and for all cylinders used in corrosive gas applications.

6.5 Non-pressure-containing attachments

6.5.1 Parts which are not submitted to pressure, such as foot rings, handles and neck rings, shall be made of steel compatible with that of the cylinder, e.g. selected to avoid corrosion couples.

6.5.2 Each attachment shall be clear of longitudinal and circumferential joints, and so designed as to permit inspection of the attachment welds and to avoid trapping water.

6.5.3 A foot ring or other support shall be fitted to the cylinder when required to provide stability, and attached so as to permit inspection of the bottom circumferential weld. Permanently attached foot rings shall be drained and the space enclosed by the foot ring shall be ventilated.

6.5.4 In the case of cylinders subjected to a cryoforming process, the non-pressure-retaining attachments shall be welded to the cylinder preformed component before cryoforming.

6.6 Valve protection

6.6.1 Valves of cylinders of more than 5 l water capacity shall be protected from damage which could cause release of gas, either by the design of the cylinder (e.g. protective shroud) or by a valve protection device (in accordance with ISO 11117).

6.6.2 When a protective shroud is used, it shall fulfil the requirements of the drop test, as described in ISO 11117.

6.6.3 The requirements of 6.6.1 and 6.6.2 may be waived when the cylinders are intended to be conveyed in bundles or cradles or when, transported as single cylinders, some other effective valve protection is provided and it can be demonstrated that the valve can withstand damage without leakage of product (see ISO 10297).

6.7 Neck threads

The internal neck threads shall conform to a recognized standard to permit the use of a corresponding valve, thus minimizing neck stresses following the valve torquing operation. Internal neck threads shall be checked using gauges corresponding to the specific neck thread, or by an alternative method. Particular care shall be taken to ensure that neck threads are accurately cut, are of full form and free from any sharp profiles, e.g. burrs.

NOTE For example, where the neck thread is specified to be in accordance with ISO 10920, the corresponding gauges are specified in ISO 11191.

6.8 Visual examination

6.8.1 Unacceptable defects

Before assembly, the pressure envelope parts of the cylinder shall be examined for uniform quality and freedom from unacceptable defects, examples of which are given in Annex B.

6.8.2 Welds

6.8.2.1 Before the cylinders are closed, longitudinal welds shall be visually examined from both sides. Permanent backing strips shall not be used with longitudinal welds.

6.8.2.2 All welds shall have a smooth finish without concavity, and shall merge into the parent material without under-cutting or abrupt irregularity.

6.8.2.3 All butt welds shall have full penetration (see Figures 8 and 9). The excess thickness shall be such that the weld integrity is not compromised. Joggled butt welds shall have their penetration verified by macro etch, bend testing or tensile testing. Lap welds shall have their penetration verified by macro etch and bend testing. The tests shall be carried out as specified in Clause 8.

6.8.2.4 Radiographic examination, radiosopic examination, or non-destructive examination (NDE) carried out using another suitable method shall be as specified in Annex A.

6.8.3 Out of roundness

The out of roundness of the cylindrical shell shall be limited such that the difference between the maximum and the minimum outside diameter in the same cross-section is not more than 1 % of the mean of these diameters for two-piece cylinders, and not more than 1,5 % of the mean of these diameters for three-piece cylinders.

6.8.4 Straightness

Unless otherwise specified on the manufacturing drawing, the maximum deviation of the cylindrical part of the shell from a straight line shall not exceed 0,3 % of the cylindrical length.

6.8.5 Verticality

When the cylinder is standing on its base, the cylindrical shell and concentric opening shall be vertical to within 1 % of the cylindrical length.

7 New design tests

7.1 General requirements

7.1.1 Testing shall be carried out for each new design of cylinder.

A cylinder shall be considered to be of a new design, compared with an existing design, in the case of one of the following:

- it is manufactured in a different factory;
- it is manufactured by a different welding or manufacturing process or there is a radical change in an existing process, e.g. change in heat treatment, change in cold working or cryoforming operation;
- it is manufactured from a steel of different specified chemical composition range;
- it is given a different heat treatment, as specified in 4.3;
- there is a change in base profile, e.g. concave, convex, hemispherical, or there is a change in the base thickness/cylinder diameter ratio;
- the guaranteed minimum yield stress (R_e) and/or the guaranteed minimum tensile strength (R_g) has changed;

- the overall length of the cylinder has increased by more than 50 % (cylinders with a length/diameter ratio less than 3 shall not be used as reference cylinders for any design with this ratio greater than 3);
- the outside diameter has changed by more than ± 2 %;
- the guaranteed minimum wall thickness (a') or the guaranteed minimum end thickness (b') has been decreased;
- the hydraulic test pressure has been changed (where the cylinder is to be used for a lower pressure duty than that for which the cylinder was approved, it shall not be deemed a new design);
- the cryoforming factor (f_c) varies by more than ± 10 % for cryoformed cylinders; or
- a different cryoforming temperature is used.

7.1.2 A technical specification of the cylinder, including design drawing, design calculations, material details, welding and manufacturing process and heat treatment, shall be prepared by the manufacturer and attached to the design test certificate (see Annex C).

7.1.3 A minimum of 25 cylinders, which shall be guaranteed by the manufacturer to be representative of a new design, shall be made available for design testing. However, if the total production is less than 50 cylinders, enough cylinders shall be made to complete the tests required, in addition to the production quantity. In this case, the design test certificate is limited to the particular batch.

7.1.4 The testing process shall include the verifications and tests listed in 7.2.1 and 7.2.2 respectively.

7.2 Verifications and tests

7.2.1 Verifications

It shall be verified that:

- the requirements of Clause 4 (materials) are fulfilled;
- the design conforms to the requirements of Clause 5;
- the thickness of the walls and domed ends of two cylinders meet the requirements of 5.2 to 5.5, the measurements being taken at a minimum of three transverse sections of the cylindrical part and on a longitudinal section of the base and head;
- the requirements of Clause 6 and Annex A are fulfilled for all cylinders selected.

7.2.2 List of tests

The following tests shall be performed on cylinders selected after the welds of the cylinders have been visually inspected:

- the tests specified in 8.3 (tensile test), 8.4 (bend test), 8.5 (impact test) where applicable, and 8.6 (macroscopic examination of weld cross-sections) on two cylinders, the test pieces being identifiable to the batch;
- the test specified in 7.3.1 (hydraulic burst test) on two cylinders, the cylinders bearing representative stamp marking;
- radiographic examination, radiosopic examination or non-destructive examination carried out using another suitable method, in accordance with Annex A;

- the test specified in 7.3.2 (pressure cycling) on one cylinder, the cylinder bearing representative stamp marking;
- the test specified in 7.3.3 (corrosion test) on one cylinder when the cylinders are intended for use in corrosive gas service (see ISO 11114-1) and are manufactured from austenitic or duplex stainless steels.

These tests shall be performed with finished cylinders after all manufacturing processes, including cold forming or cryoforming steps, have been completed.

7.3 Descriptions of tests

7.3.1 Hydraulic burst test

7.3.1.1 Cylinders subjected to this test shall bear markings in accordance with the complete stamp markings required for the finished cylinder. The hydraulic burst test shall be carried out with equipment which enables the pressure to be increased at a controlled rate, not more than 0,1 MPa/s (1 bar/s), until the cylinder bursts and the change in pressure with time is recorded.

7.3.1.2 The burst pressure (p_b) shall be at least 1,6 times the test pressure. The observed yield pressure (p_y) shall be equal to or greater than the value calculated by the following formula:

$$p_y \geq p_h / F \quad (9)$$

The burst test shall not cause any fragmentation of the cylinder.

The main fracture shall not show any brittleness, i.e. the edges of the fracture shall not be radial but shall be at an angle to a diametral plane, and shall display a reduction of area throughout their thickness.

7.3.2 Pressure cycling test

7.3.2.1 The pressure cycling test shall be carried out on three cylinders bearing the required stamp markings. See Clause 11 for the particular requirements concerning the stamp marking on the dome ends.

7.3.2.2 This test shall be carried out with a non-corrosive liquid, subjecting the cylinder to successive reversals at an upper cyclic pressure which is equal to the hydraulic test pressure (p_h). The value of the lower cyclic pressure shall not exceed 10 % of the upper cyclic pressure. The frequency of reversals of pressure shall not exceed 0,25 Hz (15 cycles/min). The temperature measured on the outside surface of the cylinder shall not exceed 50 °C during the test.

7.3.2.3 The cylinder shall be subjected to 12 000 cycles without leakage or failure.

7.3.2.4 The thickness of the centre of the cylinder bases shall be measured and recorded on the design test certificate. The centre of the cylinder base of production cylinders shall not be more than 15 % thinner than the recorded thickness for the prototypes.

7.3.3 Corrosion test

An intergranular corrosion test shall be carried out in accordance with ISO 3651-2 on one cylinder for design testing for cylinders which are intended to be used for corrosive applications and are manufactured from steels specified in 4.2. The specimens shall be taken from a part of the cylinder providing a specimen geometry suitable for bend testing.

The mechanical properties may depend on the location of the samples, therefore the exact location of the samples shall be identified and this location shall be as indicated in Figure 4 or Figure 5. Two specimens shall be taken from the location shown in Figure 4 or Figure 5, as appropriate.

Corrosive gases are listed in ISO 11114-1, and cylinders for such gases shall be stamp-marked "H", as specified in ISO 13769.

7.4 Design testing certificate

If the results of the checks are satisfactory, a design testing certificate shall be issued, a typical example of which is given in Annex C.

8 Batch tests

8.1 General

For the purpose of carrying out the batch testing, a random sample of cylinders, as indicated in Table 1, shall be taken from each batch, as defined in 3.1.6. A batch shall consist of a maximum of 3 000 cylinders. All batch tests shall be carried out on finished cylinders.

Table 1 — Batch sampling

Batch size	Number of cylinders taken as samples	Number of cylinders to be tested		
		Mechanical tests ^a	Burst tests ^b	Radiography
up to 200	2	1	1	See Annex A
201 to 500	3	1	2	
501 to 1 500	9	2	7	
1 501 to 3 000	18	3	15	
^a Mechanical tests comprise tensile tests (in accordance with 8.3), bend tests (in accordance with 8.4), impact tests where applicable (in accordance with 8.5), and macroscopic examination of weld cross-sections (in accordance with 8.6).				
^b In accordance with 7.3.1.				

8.2 Information

For the purpose of batch testing, the manufacturer shall provide the following:

- the design test certificate;
- the certificates for the material of construction, as required in 4.1.6, stating the cast analyses of the steel supplied for the construction of the cylinders;
- a list of cylinders, stating serial numbers and stamp markings as required;
- a statement of the thread checking method used, and the results thereof.

8.3 Tensile test

8.3.1 General

The tensile test on parent material shall be carried out on a test sample taken from a finished cylinder in accordance with the requirements of ISO 6892. The two faces of the test sample formed by the inside and the outside surfaces of the cylinder shall not be machined. Only the ends may be flattened, by cold pressing, for gripping in the test machine. The tensile test on welds shall be carried out in accordance with 8.3.3.

8.3.2 Tensile test samples from parent material

8.3.2.1 The following test samples shall be taken from the parent material (see Figure 4 for two-part cylinders and Figure 5 for three-part cylinders):

- one tensile test sample from either of the ends (if the ends are of materials from different suppliers, a tensile test sample shall be taken from each end);
- one longitudinal tensile test sample (for three-part cylinders from the section 180° away from the longitudinal weld); for cold formed or cryoformed cylinders, the tensile samples shall be taken from the middle section of the cylindrical shell.

8.3.2.2 The values obtained for the yield stress (R_{ea}) and tensile strength (R_m) shall not be less than those guaranteed by the cylinder manufacturer and not less than those given in ISO 9328-7. For cylinders subjected to heat treatment, elongation values shall be at least 14 %. Lower elongation values are to be expected for non-heat-treated cylinders if the result of the burst test is clearly without fragmentation.

8.3.3 Tensile test samples taken from welds

8.3.3.1 The following test samples shall be taken from welds:

- one tensile test sample from any longitudinal weld;
- one tensile test sample taken from each circumferential weld, if made by different welding procedures.

8.3.3.2 The tensile test transverse to the weld shall be carried out on a test sample having a reduced section 25 mm wide over a length of 15 mm beyond the edge of the weld. Outside this central part, the width of the test sample shall increase progressively (see Figure 6).

8.3.3.3 The tensile strength value obtained shall be at least equal to the minimum value specified in 8.3.2.2 for the parent metal, regardless of the position of the fracture.

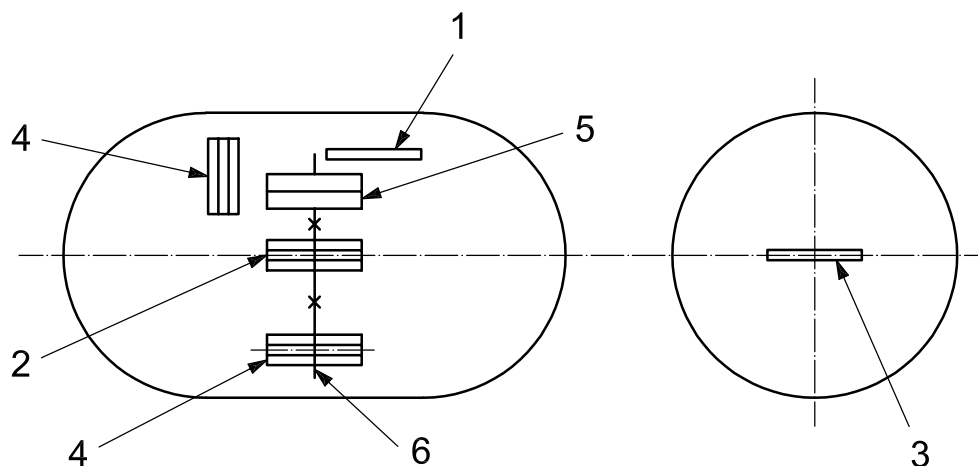

Key

- 1 1 tensile test piece
- 2 1 tensile test piece, 1 root bend test piece, 1 face bend test piece
- 3 1 tensile test piece (required only if insufficient cylindrical length available)
- 4 notch impact test piece
- 5 corrosion test piece
- 6 weld

Figure 4 — Test pieces from two-part cylinders

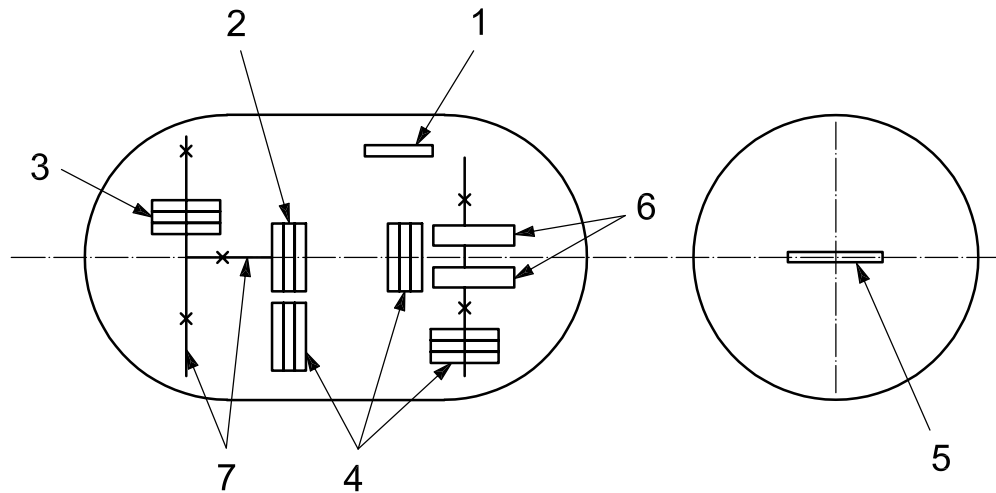
**Key**

- 1 1 tensile test piece
- 2 1 tensile test piece, 1 root bend test piece, 1 face bend test piece
- 3 1 tensile test piece (required only if welded by a different process from longitudinal weld, see 8.3.2.1 and 8.3.3.1)
- 4 impact test piece
- 5 1 tensile test piece
- 6 1 corrosion test piece
- 7 welds

Figure 5 — Test pieces from three-part cylinders

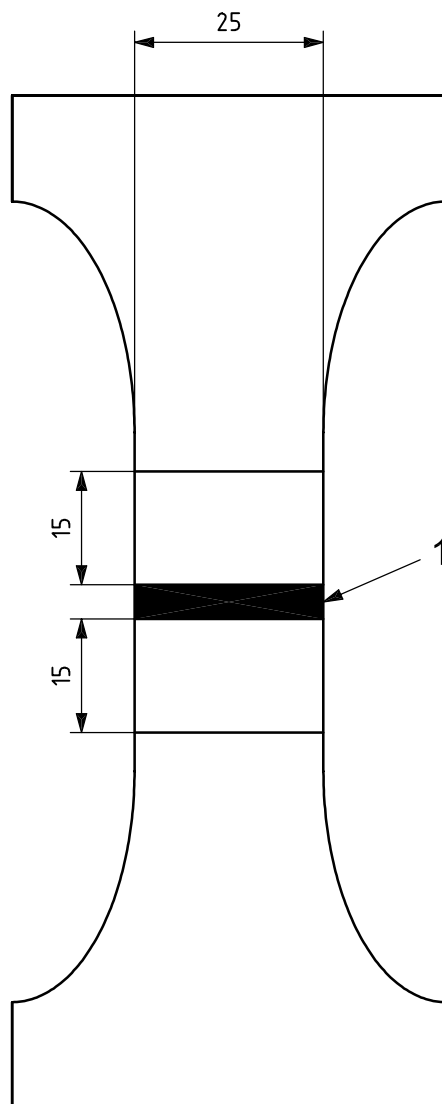
**Key**

1 weld

Figure 6 — Dimensions of test sample**8.4 Bend test**

8.4.1 The bend test shall be carried out in accordance with ISO 7438. Specimens shall be taken in accordance with Figure 4 or Figure 5, with dimensions as shown in Figure 7.

8.4.2 The following bend tests are required:

- one root and one face bend test from any longitudinal weld;
- one root and one face bend test from each circumferential weld, if made by different welding processes.

8.4.3 The test piece shall not crack when bent inwards around a former until the inside edges are not further apart than the diameter of the former (see Figure 10). The former shall be placed in the centre of the weld while the test is being performed.

8.4.4 The ratio n between the diameter (D_f) of the former and the thickness (t) of the test sample shall be as shown in Table 2.

Table 2 — Bend test requirements

Actual tensile strength R_m MPa	Value of n
$R_m \leq 440$	2
$440 < R_m \leq 520$	3
$520 < R_m \leq 600$	4
$600 < R_m \leq 700$	5
$700 < R_m \leq 800$	6
$800 < R_m \leq 900$	7
$R_m > 900$	8

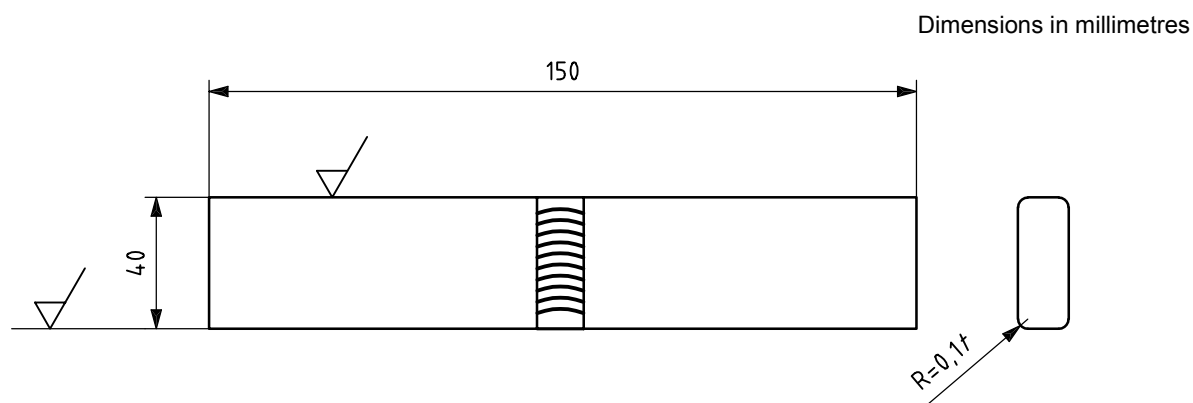
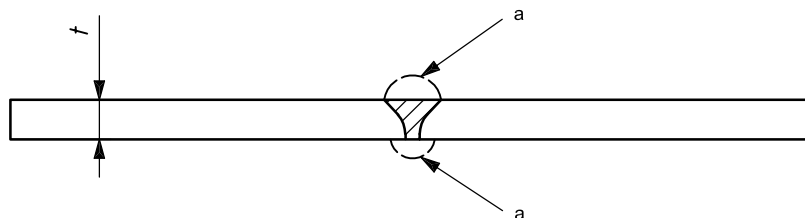
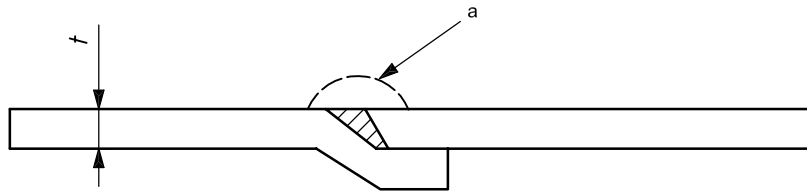

Figure 7 — Transverse guided bend test — Specimen preparation details



a Weld dressed flush.

Figure 8 — Transverse guided bend test — Butt weld specimen



a Weld dressed flush.

Figure 9 — Transverse guided bend test — Joggle joint (joggle butt) weld specimen

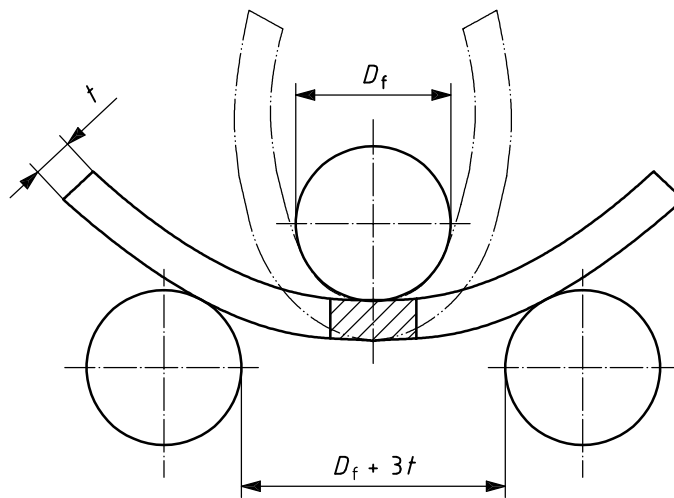

Figure 10 — Illustration of bend test

8.5 Impact test

8.5.1 The impact test is not required for cylinders where the wall thickness is less than 5 mm. This test is also not required for cylinders manufactured from austenitic or duplex steels in the solution annealed condition.

8.5.2 Except for the requirements set out below, the impact test shall be carried out in accordance with ISO 14556.

8.5.3 The test temperature shall be at least that specified in the material specification, e.g. EN 13445-2, with a minimum design reference temperature of $-50\text{ }^{\circ}\text{C}$. The actual cylinder wall thickness shall be used.

8.5.4 The following impact test samples shall be taken (see Figure 4 or 5 as appropriate):

- three impact test samples from each parent material;
- three impact test samples from the longitudinal welds;
- three impact test samples from one of the circumferential welds.

8.5.5 For the parent material samples, the transverse impact test pieces shall be taken from the wall of the cylinder. The notch shall be perpendicular to the face of the wall. The test pieces shall be machined on four faces only, with the inner and outer faces of the cylinder wall unmachined. For outside diameters equal to or less than 140 mm, longitudinal impact tests may be performed instead of transverse tests.

8.5.6 For the welds, impact test pieces transverse to the weld shall be taken, with the exception of cylinders with outside diameters ≤ 40 mm, where longitudinal test pieces may be taken. The notch shall be in the centre of the weld and shall be perpendicular to the face of the cylinder. The test pieces shall be machined on all six faces. If the wall thickness does not permit a final test piece width of 10 mm, the width shall be as near as practicable to the nominal thickness of the cylinder wall.

8.5.7 The average of three specimens shall meet the relevant value specified in Table 3. No specimen shall show a value below 70 % of the average value.

Table 3 — Minimum values for impact test pieces

Tensile strength R_g		≤ 750 MPa		> 750 MPa	
Material		Parent	Weld	Parent	Weld
Impact energy J/cm ²	$D > 140$ mm ^a	45	45	35	35
	$D \leq 140$ mm ^b	60	50	50	50
^a Transverse test. ^b Longitudinal test.					

8.6 Macroscopic examination of weld cross-sections

A macroscopic weld examination for each type of welding procedure shall be performed. It shall show complete fusion and shall be free of any assembly faults or unacceptable defects, as defined in A 3.2.

NOTE Duplex steels have a specific microstructure, which needs closer examination than non-duplex steels.

8.7 Checks and verifications

The following checks and verifications shall be carried out on each batch of cylinders.

- Ascertain that a batch test certificate has been obtained and that the cylinders conform to it.
- Check whether the requirements set out in Clauses 4, 5 and 6 have been met, and in particular check by an external and internal examination of the cylinders whether the construction and checks carried out by the manufacturer in accordance with Clause 6 are compliant. The visual examination shall cover at least 10 % of the cylinders submitted. However, if a defect as described in Table B.1 is found, 100 % of the cylinders shall be visually inspected.
- Carry out or witness the tests specified in 8.3 (tensile test), 8.4 (bend test), 8.5 (impact test) where applicable, 8.6 (macroscopic examination of weld cross-sections) and 7.3.1 (hydraulic burst test) on the number of cylinders specified in 8.1.
- Assess the results of the NDE as specified in Annex A.
- Check whether the marking requirements set out in Clause 11 have been met.
- Check whether the information supplied by the manufacturer is correct; random checks shall be carried out.

9 Tests on every cylinder

9.1 Pressure test

Each cylinder shall be subjected to a pressure test. When carrying out a pressure test, a suitable fluid, normally water, shall be used as the test medium. If water is used as the test medium, the chloride content shall be controlled to avoid the risk of corrosion.

NOTE A pneumatic pressure test can be used, provided that measures are taken to ensure safe operation and to contain any energy which can be released, which is considerably more than that in the hydraulic test.

The pressure in the cylinder shall be increased at a controlled rate until the pressure (p_h) is reached. The cylinder shall remain under pressure p_h for at least 30 s to establish that the pressure does not fall, that there is no visible deformation of the cylinder and that there are no visible leaks.

9.2 Hardness test

Every cylinder which has been subjected to cold forming or cryoforming shall be hardness tested in the centre of the cylindrical part, in accordance with ISO 6506-1. The hardness test shall be carried out after the cold forming or cryoforming procedure. The hardness values thus determined shall be within the limits specified by the cylinder manufacturer for the material, and the cold forming or cryoforming conditions used for the production of the cylinder.

9.3 Leakage test

Where the manufacturing process has included a pneumatic pressure test as in 9.1, no leakage test is required. Otherwise, each cylinder shall be subjected to a leakage test, e.g. low pressure pneumatic test or helium leak test. There shall be no leakage from the cylinder.

10 Failure to meet test requirements

In the event of failure to meet test requirements, retesting shall be carried out as follows.

- a) If there is evidence of a fault in carrying out a test, or an error of measurement, a further test shall be performed. If the result of the test is satisfactory, the first test result shall be ignored.
- b) If the test has been carried out in a satisfactory manner, the cause of test failure shall be identified:
 - 1) if the failure is considered to be due to the heat treatment (if applied), the manufacturer may subject all the cylinders of the batch to one further heat treatment;
 - 2) if the failure is not due to the heat treatment (if applied), all the identified defective cylinders shall be rejected or repaired by an approved method. The repaired cylinders are then considered to be a new batch.

The cylinders from the repaired batch and the remaining cylinders from the original batch shall be considered as two separate batches. In both cases, the new batch shall be inspected and tested. Only the relevant tests needed to prove the compliance to the standard shall be performed again. If one or more tests do not conform, all the cylinders of the original batch shall be rejected.

11 Markings

11.1 Markings shall conform to ISO 13769.

11.2 No embossing shall be permitted on cylinder sidewalls.

11.3 Where marking is on the ends of cylinders, it shall be demonstrated in the fatigue and burst test that failure does not initiate in the markings, and that the markings are legible.

12 Certificate

Each batch of cylinders shall be covered by a certificate to the effect that the cylinders meet the requirements of this part of ISO 18172 in all respects. Annex C provides examples of design and batch testing certificates.

Annex A (normative)

Radiographic examination of welds

A.1 General

The radiographic examination shall conform to the techniques in ISO 17636. Radiographs shall show complete penetration of weld and the absence of unacceptable defects (as specified in Annex B). The test equipment shall be operated by personnel certified to at least level 1 of ISO 20807 and supervised by personnel certified to at least level 2.

The radiographic examination may be replaced by a radioscapy, or another suitable method, if the applied NDE method is carried out according to a process that provides the same quality of examination as radiographic examination and a verifiable record of the result.

A.2 Requirements

A.2.1 Radiographic examinations shall be carried out as listed in Tables A.1 and A.2 after the pressure test in 9.1.

Table A.1 — Longitudinal welds

	Butt weld	Joggle weld
Radiographic control frequency ^a	1 %	2 %
% length	100 %	100 %
Intersection of joint	all	all
Overlapping zone of welds	all	all
^a One test at the beginning and one test at the end, per shift and per machine.		

Table A.2 — Circumferential welds

	Butt weld	Joggle weld
Radiographic control frequency ^a	1 %	1 %
% length	100 %	100 %
Intersection of joint	100 %	all
Overlapping zone of welds	yes	yes
^a One test at the beginning and one test at the end, per shift and per machine.		

A.2.2 Welded joints shall be radiographed for distances beyond the intersection of each joint, as defined in Figure A.1.

A.2.3 If the radiographs show no unacceptable defects and the batch tests are completed satisfactorily, the cylinders shall be acceptable.

A.2.4 Should any of the radiographs show an unacceptable defect, the whole of the production of the relevant shift shall be radiographed 100 % on all welds.

Until the cause of the defect has been established and rectified, the subsequently produced cylinders shall be radiographed on all welds.

Where more than one welding machine is used for production, the above procedure shall apply to each such machine.

A.3 Detection of defects

A.3.1 Assessment of the weld radiographs shall be based on the original films, in accordance with the practice recommended in ISO 2504:1973, Clause 6.

A.3.2 The following imperfections, as defined in ISO 5817, are not permitted:

- cracks, inadequate welds, or lack of penetration or lack of fusion of the weld;
- any elongated inclusion, or any group of rounded inclusions, in a row where the length represented over a weld length of $12a$ is greater than 6 mm;
- any gas pore measuring more than $(a/3)$ mm;
- any gas pore measuring more than $(a/4)$ mm, which is 25 mm or less from any other gas pore;
- gas pores over any 100 mm length where the total area of all the pores, in mm^2 , is greater than $2a$.

Dimensions in millimetres

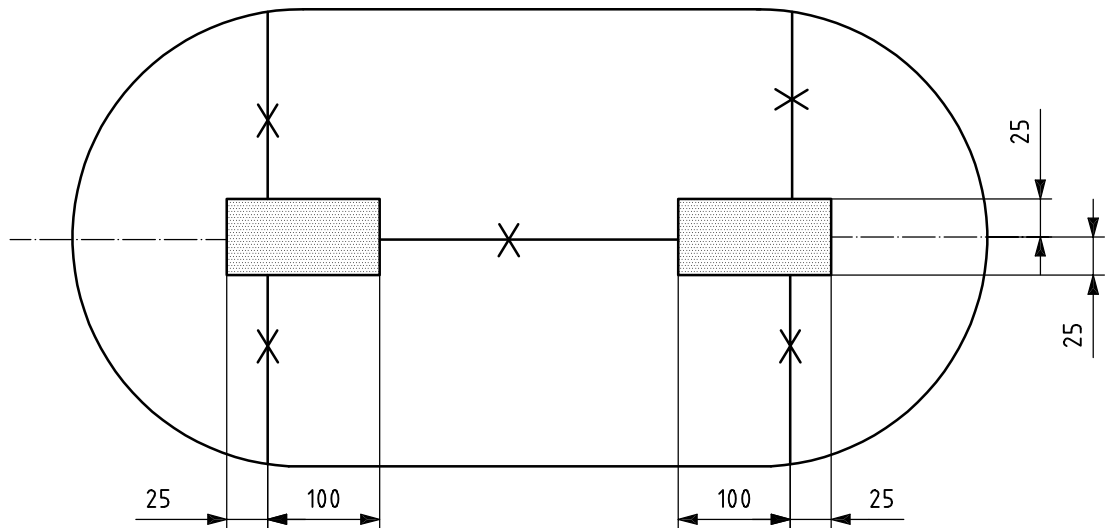

Figure A.1 — Extent of spot-radiography at weld intersections

Annex B (normative)

Description and evaluation of manufacturing defects and conditions for rejection of welded stainless steel gas cylinders at time of visual inspection

B.1 Introduction

Several types of defects can occur during the manufacturing of a welded stainless steel gas cylinder. Such defects can be mechanical or material. They can be due to the basic material used, the manufacturing process, heat treatments, marking operations and other occurrences during manufacture.

The aim of this annex is to identify the manufacturing defects most commonly encountered, and to provide rejection criteria for the inspectors who perform the visual inspection. Nevertheless, the inspector needs to have extensive field experience and good judgement in order to be able to detect, evaluate and make a judgement on a defect at the time of the visual inspection (see ISO 5817).

B.2 General

B.2.1 Visual examination shall be carried out in accordance with ISO 17637. It is essential to perform the internal and external visual inspection in good conditions. Appropriate sources of illumination with sufficient intensity shall be used, e.g. at least 50 lux.

The surface of the metal, in particular that of the inner wall, shall be clean, dry and free from oxidation products, corrosion and scale because these could obscure more serious defects. Where necessary, before further inspection, the surface shall be cleaned under closely controlled conditions in order not to damage the cylinder in any way.

When this visual inspection is carried out after the circumferential welding, the internal neck area shall be examined by means of an endoscope, dental mirror or other suitable appliance.

B.2.2 Defects may be repaired in accordance with Table B.1. It shall be ensured that any repair method used will not impair the safety of the cylinders. Great care shall be taken to avoid introducing new defects. After such repair, the cylinders shall be re-examined and, if necessary, the wall thickness shall be rechecked.

B.3 Manufacturing defects

The most commonly found manufacturing defects and their definitions are listed in Table B.1. Rejection limits for repair or reject are included in this table. These rejection limits have been established on the basis of considerable field experience. They apply to all sizes and types of cylinder and service conditions. Nevertheless, some customer specifications, some types of cylinder or some special service conditions may require more stringent criteria.

B.4 Rejected cylinders

All rejected cylinders shall be scrapped and will not be used for any other service.

Table B.1 — Manufacturing defects in welded stainless steel gas cylinders and rejection criteria

Defect	Description	Conditions and/or actions	Repair or scrap
Bulge	Visible swelling of the cylinder	All cylinders with such a defect	Scrap
Dent	Depression in the cylinder that has neither penetrated nor removed metal (see Figure B.1) and is greater in depth than 1 % of the outside diameter of the cylinder	<ul style="list-style-type: none"> — When the depth of the dent exceeds 3 % of the external diameter of the cylinder — When the diameter of the dent is less than 15 times its depth 	Repair if possible, followed by heat treatment of the cylinder, or scrap Repair if possible, followed by heat treatment of the cylinder, or scrap
Cut or gouge	Sharp impression where metal has been removed or redistributed and whose depth exceeds 5 % of the cylinder wall thickness	When the depth of the cut or gouge exceeds 10 % of the wall thickness, or when the length exceeds 25 % of the outside diameter of the cylinder	Repair if possible by grinding ^a , or scrap
Lamination	Layering of the material within the cylinder wall, sometimes appearing as a discontinuity or crack and lap or bulge at the surface (see Figure B.2)	<ul style="list-style-type: none"> — Inside defect: all cylinders with such defect — Outside defect: all cylinders with such defect 	Repair if possible by grinding ^a , or scrap Repair if possible by grinding ^a , or scrap
Crack	Split or rift in the metal	All cylinders with such defects	Scrap
Internal neck threads damaged	Neck threads damaged, with dents, cuts, burrs or out of tolerance	<ul style="list-style-type: none"> — When the design permits, threads may be re-tapped and rechecked by the appropriate thread gauge and carefully visually re-examined. The appropriate number of effective threads shall be achieved. — If not repairable 	Repair Scrap
Non-secure neck ring not subjected to pressure	Neck ring turns under application of low torque or pulls off under low axial load ^b	All cylinders presenting such a defect	Repair if possible, or scrap
Nonconformity with design drawing			Repair if possible, or scrap
Illegible, modified or incorrect stamping	Marking by means of a metal punch	All cylinders presenting such a defect	Repair if possible, or scrap

^a After any repair by grinding, it should be checked that the remaining wall thickness is still above the guaranteed minimum wall thickness.

^b The manufacturer should ensure that the axial load required to remove the neck ring is greater than 10 times the weight of the empty cylinder and not less than 1 000 N, and that the minimum torque required to turn the neck ring is greater than 100 Nm.

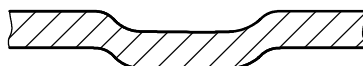
**Figure B.1 — Example of dent****Figure B.2 — Example of lamination**

Annex C
(informative)

Examples of design and batch testing certificates

C.1 Design test certificate

Issued by on the basis of
.....
applying ISO 18172-2
..... concerning WELDED STAINLESS STEEL GAS CYLINDERS

Certificate No. Date

Type of cylinder(Description of the family of cylinders to which the certificate applies, e.g. cylinder drawing number)

p_h D_{min} D_{max} a' b'

L_{min} L_{max} V_{min} V_{max}

Cylinder base thicknesses: Cylinder 1) Cylinder 2) Cylinder 3)

Manufacturer or agent (Name and address of manufacturer or its agent)

Details of the results of the design testing of the cylinder and the main features of the type are annexed.

All information may be obtained from (Name and address of the certificate issuer)

Date Place

Signature

C.2 Information to be attached to the design test certificate

The documentation required in 7.1.2 should be attached to the design test certificate.

C.3 Batch certificate

Application of Standard

Issuer

.....

Date

Design certificate No.

Description of vessels (drawing number)

.....

Production testing No.

Manufacturing batch No. to

Manufacturer

(Name and address)

.....

.....

Country Mark

Owner

(Name and address)

.....

.....

Customer

(Name and address)

Date Place

Signature

Table C.1 — Batch — Measurements of sample cylinders

Test No.	Batch consisting of No. to No.	Water capacity l	Mass empty kg	Minimum measured thickness mm	
				Shell	Domed end

Table C.2 — Batch — Non-destructive test results

REPORT OF RADIOGRAPHIC EXAMINATIONS OF WELDS

Customer _____ Type: _____ Batch No. _____

Parameters									
Radiographic source: _____						Position source/Film 			
Amperage: _____ mA		Voltage: _____ kV		Material thickness: _____ mm					
Exposure time: _____ s		Dist. Source/Film: _____ mm		I.Q.I.: _____					
Type of film: _____				Density: _____					
Data						Interpre- tation	Results	Comments	Notation convention W
Day/ month	Machine No.	Cylinder No.	Welder No.	Type of joint	Radio- graph No.				
									A – Void
									Aa – Spheroid
									Ab – Wormhole
									Ad – Surface
									B – Pores
									Ba – Isolated
									Bb – Aligned
									Bc – Regular distributed
									Bd – Grinding defects
									Be – Poor restart
									Bf – Tee defects
									C – Lack of fusion
									D – Lack of penetration
									Da – In bottom of chamfer
									Db – Lack of inter-run fusion
									E – Crack
									Ea – Longitudinal
									Eb – Transverse
									Ec – Crater
									F – Undercut
									Fa – External cavity
									Fb – Root cavity
									Fc – Excess weld thickness
									Fd – Excess penetration
									Fe – Lack of penetration
									Ff – Fluxing
									G – Slag inclusion
									H – Metallic inclusion
									J – Oxide inclusion
									K – Pit
									Ka – Stop/start crater
									L – Weld splatter
									T – Tungsten Inclusions
Type of weld						Results			Operator
Type of material: _____						No defect: –			
Weld procedure: _____						Acceptable: /			
Position: _____						To repair: +			
Weld geometry: _____						No defect after repair: =			Date: ____/____/____
						Acceptable after repair: ×			
						Scrap: 0			
Remarks:									
Density of the film conforms to the requirements of ISO 17636									
Smallest wire visible: _____ I.Q.I.n°: _____ – _____ mm									

Table C.3 — Batch — Mechanical tests carried out on sample cylinders

Test and examination results									
Test No.	Cast No.	Test piece in accordance with Figure 6	Yield point R_{ea} MPa	Tensile strength R_m MPa	Elongation A %	Bend test 180° without cracking	Burst test MPa (bar)	Brinell hardness test	Description of the fracture
Minimum values specified									

I, the undersigned, hereby declare that I have checked that the verification operations, tests and checks prescribed in ISO 18172-2 have been carried out successfully.

Special remarks

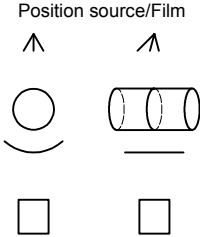
.....

General remarks

.....

Certified on (date)

.....

(Place)

.....

(Signature of the issuer)

On behalf of

.....

Bibliography

- [1] ISO 9809-3, *Gas cylinders — Refillable seamless steel gas cylinders — Design, construction and testing — Part 3: Normalized steel cylinders*
- [2] ISO 10297, *Transportable gas cylinders — Cylinder valves — Specification and type testing*
- [3] ISO 10920, *Gas cylinders — 25E taper thread for connection of valves to gas cylinders — Specification*
- [4] ISO 11191, *Gas cylinders — 25E taper thread for connection of valves to gas cylinders — Inspection gauges*
- [5] EN 13445-2, *Unfired pressure vessels — Part 2: Materials*
- [6] ST/SG/AC.10/1/Rev.13 *Recommendations on the Transport of Dangerous Goods: Model Regulations*, Thirteenth revised edition 2003

BSI — British Standards Institution

BSI is the independent national body responsible for preparing British Standards. It presents the UK view on standards in Europe and at the international level. It is incorporated by Royal Charter.

Revisions

British Standards are updated by amendment or revision. Users of British Standards should make sure that they possess the latest amendments or editions.

It is the constant aim of BSI to improve the quality of our products and services. We would be grateful if anyone finding an inaccuracy or ambiguity while using this British Standard would inform the Secretary of the technical committee responsible, the identity of which can be found on the inside front cover.
Tel: +44 (0)20 8996 9000. Fax: +44 (0)20 8996 7400.

BSI offers members an individual updating service called PLUS which ensures that subscribers automatically receive the latest editions of standards.

Buying standards

Orders for all BSI, international and foreign standards publications should be addressed to Customer Services. Tel: +44 (0)20 8996 9001.
Fax: +44 (0)20 8996 7001. Email: orders@bsi-global.com. Standards are also available from the BSI website at <http://www.bsi-global.com>.

In response to orders for international standards, it is BSI policy to supply the BSI implementation of those that have been published as British Standards, unless otherwise requested.

Information on standards

BSI provides a wide range of information on national, European and international standards through its Library and its Technical Help to Exporters Service. Various BSI electronic information services are also available which give details on all its products and services. Contact the Information Centre.
Tel: +44 (0)20 8996 7111. Fax: +44 (0)20 8996 7048. Email: info@bsi-global.com.

Subscribing members of BSI are kept up to date with standards developments and receive substantial discounts on the purchase price of standards. For details of these and other benefits contact Membership Administration.
Tel: +44 (0)20 8996 7002. Fax: +44 (0)20 8996 7001.
Email: membership@bsi-global.com.

Information regarding online access to British Standards via British Standards Online can be found at <http://www.bsi-global.com/bsonline>.

Further information about BSI is available on the BSI website at <http://www.bsi-global.com>.

Copyright

Copyright subsists in all BSI publications. BSI also holds the copyright, in the UK, of the publications of the international standardization bodies. Except as permitted under the Copyright, Designs and Patents Act 1988 no extract may be reproduced, stored in a retrieval system or transmitted in any form or by any means – electronic, photocopying, recording or otherwise – without prior written permission from BSI.

This does not preclude the free use, in the course of implementing the standard, of necessary details such as symbols, and size, type or grade designations. If these details are to be used for any other purpose than implementation then the prior written permission of BSI must be obtained.

Details and advice can be obtained from the Copyright & Licensing Manager.
Tel: +44 (0)20 8996 7070. Fax: +44 (0)20 8996 7553.
Email: copyright@bsi-global.com.