



BSI Standards Publication

Fine Ceramics (Advanced Ceramics, Advanced Technical Ceramics) — Determination of antiviral activity of semiconducting photocatalytic materials — Test method using bacteriophage Q-beta

National foreword

This British Standard is the UK implementation of ISO 18061:2014.

The UK participation in its preparation was entrusted to Technical Committee RPI/13, Advanced technical ceramics.

A list of organizations represented on this committee can be obtained on request to its secretary.

This publication does not purport to include all the necessary provisions of a contract. Users are responsible for its correct application.

© The British Standards Institution 2014.
Published by BSI Standards Limited 2014

ISBN 978 0 580 78772 0
ICS 81.060.30

Compliance with a British Standard cannot confer immunity from legal obligations.

This British Standard was published under the authority of the Standards Policy and Strategy Committee on 30 June 2014.

Amendments/corrigenda issued since publication

Date	Text affected
------	---------------

**Fine Ceramics (Advanced Ceramics,
Advanced Technical Ceramics) —
Determination of antiviral activity
of semiconducting photocatalytic
materials — Test method using
bacteriophage Q-beta**

*Céramiques techniques — Détermination de l'activité antivirale des
matériaux photocatalytiques semi-conducteurs — Méthode d'essai
utilisant le bactériophage Q-beta*





COPYRIGHT PROTECTED DOCUMENT

© ISO 2014

All rights reserved. Unless otherwise specified, no part of this publication may be reproduced or utilized otherwise in any form or by any means, electronic or mechanical, including photocopying, or posting on the internet or an intranet, without prior written permission. Permission can be requested from either ISO at the address below or ISO's member body in the country of the requester.

ISO copyright office
Case postale 56 • CH-1211 Geneva 20
Tel. + 41 22 749 01 11
Fax + 41 22 749 09 47
E-mail copyright@iso.org
Web www.iso.org

Published in Switzerland

Contents

Page

Foreword	iv
Introduction	v
1 Scope	1
2 Normative references	1
3 Terms and definitions	1
4 Symbols	2
5 Principle	3
6 Materials	3
6.1 Strains and preparation for tests	3
6.2 Media	5
7 Apparatus and equipment	6
7.1 Test equipment	6
7.2 Cover film	7
7.3 Moisture preservation glass plate	7
7.4 Glass tube or glass rod	7
7.5 Paper filter	7
7.6 Fluorescent ultraviolet lamp	8
7.7 UV radiometer	8
7.8 Punched metal sheet	8
7.9 Centrifuge	9
7.10 Sterilized syringe filter unit	9
8 Test piece	9
9 Procedure	10
9.1 General	10
9.2 Procedure for preparation of bacteria suspension	10
9.3 Procedure of preparation of test bacteriophage solution	10
9.4 Procedure of test for photocatalytic antiviral activity	11
9.5 UV irradiation condition	11
9.6 Measurement of titre of bacteriophage	12
10 Calculation	13
10.1 General	13
10.2 Calculate titre of bacteriophage	13
10.3 Test requirement fulfilment validation	13
10.4 Photocatalyst antiviral activity value calculation	14
10.5 Antiviral activity value calculation without photocatalyst	15
11 Test report	15
Annex A (informative) Reference data of comparison between influenza virus and bacteriophage Q-beta	16
Annex B (informative) Comparison of photocatalytic activities determined using ATCC23631-B1 and NBRC20012	18

Foreword

ISO (the International Organization for Standardization) is a worldwide federation of national standards bodies (ISO member bodies). The work of preparing International Standards is normally carried out through ISO technical committees. Each member body interested in a subject for which a technical committee has been established has the right to be represented on that committee. International organizations, governmental and non-governmental, in liaison with ISO, also take part in the work. ISO collaborates closely with the International Electrotechnical Commission (IEC) on all matters of electrotechnical standardization.

The procedures used to develop this document and those intended for its further maintenance are described in the ISO/IEC Directives, Part 1. In particular the different approval criteria needed for the different types of ISO documents should be noted. This document was drafted in accordance with the editorial rules of the ISO/IEC Directives, Part 2 (see www.iso.org/directives).

Attention is drawn to the possibility that some of the elements of this document may be the subject of patent rights. ISO shall not be held responsible for identifying any or all such patent rights. Details of any patent rights identified during the development of the document will be in the Introduction and/or on the ISO list of patent declarations received (see www.iso.org/patents).

Any trade name used in this document is information given for the convenience of users and does not constitute an endorsement.

For an explanation on the meaning of ISO specific terms and expressions related to conformity assessment, as well as information about ISO's adherence to the WTO principles in the Technical Barriers to Trade (TBT) see the following URL: Foreword - Supplementary information

The committee responsible for this document is ISO/TC 206, *Fine ceramics*.

Introduction

This International Standard applies to testing the antiviral activity of photocatalytic ceramics and other materials produced by either coating or mixing of a photocatalyst. The International Standard for testing the antibacterial activity that use photocatalytic materials has been published as ISO 27447. The International Standard for testing the antifungal activity that use photocatalytic materials has also been published as ISO 13125.

The test method for cloths or textiles is not included in this International Standard because of lack of photocatalytic cloths or textiles with antiviral activity using photocatalytic activity. When photocatalytic cloths or textiles with antiviral activity using photocatalytic activity have been developed, a test method for photocatalytic cloths or textiles will be proposed with the glass adhesion method in ISO 27447.

Fine Ceramics (Advanced Ceramics, Advanced Technical Ceramics) — Determination of antiviral activity of semiconducting photocatalytic materials — Test method using bacteriophage Q-beta

WARNING — Only personnel trained in microbiological techniques should carry out tests.

1 Scope

The test method in this International Standard specifies the determination of the antiviral activity of materials that contain photocatalytic materials or have photocatalytic films on the surface, by enumerating the destruction of bacteriophage Q-beta after irradiation of ultraviolet light.

NOTE In this test method, the surrogate microbe is bacteriophage Q-beta, intended as a model for Influenza viruses.

The test method in this International Standard is intended for use with different kinds of semiconducting photocatalytic materials used in construction materials, in flat sheet, board, or plate shape that are the basic forms of materials for various applications. It does not include powder, granular, or porous photocatalytic materials.

The test method in this International Standard is applicable to photocatalytic materials produced for an antiviral application. Other types of performance of photocatalytic materials, i.e. antibacterial activity, antifungal activity, decomposition of water contaminants, self-cleaning, antifogging, and air purification, are not determined by this test method.

The values expressed in this International Standard are in accordance with the International System of Units (SI).

2 Normative references

The following documents, in whole or in part, are normatively referenced in this document and are indispensable for its application. For dated references, only the edition cited applies. For undated references, the latest edition of the referenced document (including any amendments) applies.

ISO 10677, *Fine ceramics (advanced ceramics, advanced technical ceramics) — Ultraviolet light source for testing semiconducting photocatalytic materials*

ISO 27447, *Fine ceramics (advanced ceramics, advanced technical ceramics) — Test method for antibacterial activity of semiconducting photocatalytic materials*

ISO 80000-1, *Quantities and units — Part 1: General*

3 Terms and definitions

For the purposes of this document, the following terms and definitions apply.

3.1

photocatalyst

substance that carries out many functions based on oxidization and reduction reactions under photoirradiation, including decomposition and removal of air and water contaminants, deodorization, and antiviral, antibacterial, antifungal, self-cleaning, and antifogging actions

3.2 photocatalytic materials

materials in which, or on which, the photocatalyst is added by coating, impregnation, mixing, etc.

Note 1 to entry: Photocatalytic materials are used for building and road construction materials to obtain the functions mentioned in [3.1](#).

3.3 antiviral

condition decreasing the infectivity of viruses on the surface of materials

3.4 bacteriophage

type of virus which infects bacteria

Note 1 to entry: The bacteriophage used in this test method is Q-beta that is one of F-specific RNA phages. The bacteriophage Q-beta is not pathogenic to humans and animals but serves to simulate Influenza viruses that are pathogenic to humans.

Note 2 to entry: Example of test results with Influenza virus and bacteriophage Q-beta are given in [Annex A](#).

3.5 plaque

visible, clear area which is theoretically the result of infection and lysis of host cells by a single viable bacteriophage

3.6 photocatalyst antiviral activity value

difference value between the logarithms of the total number of bacteriophage plaques on photocatalytic treated materials after UV irradiation and on non-treated materials after UV irradiation

Note 1 to entry: This value includes the decrease of number of bacteriophage plaques without UV irradiation.

3.7 photocatalyst antiviral activity value for UV irradiation

difference between the logarithms of the total number of bacteriophage plaques on photocatalytic treated materials after UV irradiation and on photocatalytic treated materials kept in the dark

4 Symbols

A	average of titre of bacteriophage on non-treated specimens, just after inoculation
B_D	average of titre of bacteriophage on non-treated specimens, after being kept in a dark place
B_L	average of titre of bacteriophage on non-treated specimens, after UV irradiation of intensity L
C_D	average of titre of bacteriophage on photocatalytic treated specimens, after being kept in a dark place
C_L	average of titre of bacteriophage on photocatalytic treated specimens, after UV irradiation of intensity L
D_F	dilution factor
L	UV irradiation intensity
Log_{max}	maximum logarithmic value of titre of bacteriophage
Log_{mean}	average logarithmic value of titre of bacteriophage for three non-treated specimens

Log_{min}	minimum logarithmic value of titre of bacteriophage
N	titre of bacteriophage (plaque forming unit)
V_D	antiviral activity value without photocatalyst, after being kept in a dark place on a testing material
V_L	photocatalyst antiviral activity value, after irradiation at a constant intensity (L) on a photocatalytic testing material
ΔV	photocatalyst antiviral activity value with UV irradiation
Z	average number of plaques in two Petri dishes

5 Principle

This test method is suitable for use in development, comparison, quality assurance, characterization, reliability, and design data generation of photocatalytic materials. The method is used to obtain the antiviral activity of photocatalytic materials by the contact of a specimen with bacteriophage under UV light irradiation. The method is suitable for use with flat sheet, board, or plate-shaped materials.

The specimen of photocatalytic-treated material is inoculated with bacteriophage suspension and exposed to UV radiation of known intensity for a specified period. Following exposure, the test suspension is removed and measured by the plaque-forming method with *Escherichia coli* which is sensitive to bacteriophage Q-beta. The results obtained are compared with those obtained from inoculated specimens of non-photocatalytic treated material exposed to UV radiation under identical conditions to the treated material, and to those obtained from inoculated specimens of both photocatalytic-treated and non-treated material kept in the dark for the same period of time.

6 Materials

6.1 Strains and preparation for tests

6.1.1 Strains

The strains to be used in the test shall be the same as or equivalent to those described in [Table 1](#) and are supplied by an entity that is registered under the World Federation for Culture Collections or the Japan Society for Culture Collections. Aseptic manipulations using microorganisms can be performed in an appropriate safety cabinet.

Table 1 — Bacteriophage and bacteria strains to be used in test

Species	Strain number	Organization for the collection
Bacteriophage Q-beta	ATCC 23631-B1	American Type Culture Collection
	DSM 13768	German Collection of Microorganisms and Cell Cultures (DSMZ)
	NBRC20012	NITE Biological Resource Center
<i>Escherichia coli</i>	ATCC 23631	American Type Culture Collection
	DSM 5210	German Collection of Microorganisms and Cell Cultures (DSMZ)
	NBRC 106373	NITE Biological Resource Center

NOTE ATCC23631-B1 and NBRC20012 are not strictly the same but they are from the same origin and their photocatalytic activity effects is equivalent, as shown in [Annex B](#).

6.1.2 Bacteria preparation

- a) Inoculate *E. coli* strain into a slant culture medium [6 ml to 10 ml of LB agar (see [6.2.6](#))], incubate for 16 h to 24 h at $(37 \pm 1) ^\circ\text{C}$, and then store in refrigerator at $5 ^\circ\text{C}$ to $10 ^\circ\text{C}$.
- b) Repeat subcultures within 1 month by replicating this process.
- c) The slant culture must not be used for further storing after 1 month.
- d) The maximum number of subcultures from the original strain transferred by culture collection is 10.

NOTE In the case of bacteria stored in a deep freezer, the maximum number of subcultures from the original strain transferred by culture collection is 10.

6.1.3 Bacteriophage preparation

- a) Introduce 25 ml of LB broth with calcium (see [6.2.4](#)) into a conical flask of 300 ml and inoculate with *E. coli* strain.
- b) Incubate for $18 \text{ h} \pm 2 \text{ h}$ at $(37 \pm 1) ^\circ\text{C}$ while shaking at $110 \text{ min}^{-1} \pm 10 \text{ min}^{-1}$.
- c) Pre-warm 25 ml of LB broth with calcium in a 300 ml conical flask to $35 ^\circ\text{C}$ to $37 ^\circ\text{C}$ and inoculate with 0,025 ml of the culture prepared under item b).
- d) Incubate as above condition until a bacterial concentration will be reached at $2,0 \pm 1,0 \times 10^8 \text{ cfu/ml}$.

This procedure should be carried out several times to establish the relationship between turbidity measurements and colony counts. If sufficient data have been obtained, further work can be based on turbidity measurements only.

- e) Inoculate the bacterial culture with Q-beta from a stock solution to a final concentration of approximately $2 \times 10^7 \text{ pfu}$ (plaque forming unit)/ml [multiplicity of infection (m.o.i.) is approximately 0,1].
- f) Incubate the inoculated bacterial culture for 4 h as under b).
- g) Store the culture overnight at $4 ^\circ\text{C} \pm 2 ^\circ\text{C}$.
- h) Pour the culture into centrifuge tubes and centrifuge for 20 min at $4 ^\circ\text{C} \pm 2 ^\circ\text{C}$ at $10\,000 \text{ g}$.
- i) Pipette the supernatant carefully to a sterilized tube.
- j) Filter bacteriophage containing supernatant suspension through a sterilized syringe filter unit to purify the bacteriophage solution.
- k) Determine the titre of the bacteriophage stock solution and store at $4 ^\circ\text{C} \pm 2 ^\circ\text{C}$.
- l) To check bacterial contamination, mix 1 ml of the bacteriophage stock solution with LB agar (see [6.2.6](#)) and incubate for 24 h at $(37 \pm 1) ^\circ\text{C}$. Discard the bacteriophage stock solution if any colonies are detected.
- m) Do not use the bacteriophage stock solution with less than $1,0 \times 10^{10} \text{ pfu/ml}$ or contaminated stock solution.

NOTE 2 The titre of the phage suspension should be above $1,0 \times 10^{11} \text{ pfu/ml}$ and might reach up to $1,0 \times 10^{13} \text{ pfu/ml}$.

NOTE 3 The titre of the phage stock suspension will slowly decrease over time.

6.2 Media

6.2.1 General

Commercial media of same components described below can be used.

Volume of prepared media can be adjusted in accordance with the number of specimens.

6.2.2 1/500 Nutrient broth (1/500 NB)

For 1 000 ml of purified water, take 3,0 g of meat extract, 10,0 g of peptone, and 5,0 g of sodium chloride, put them in a flask, and dissolve them thoroughly. When the contents are thoroughly dissolved, use a solution of sodium hydroxide or hydrochloric acid to bring the pH to $(7,1 \pm 0,1)$ at 25 °C. Dilute this medium by 500 times using purified water, and set the pH to $(7,0 \pm 0,2)$ at 25 °C using hydrochloric acid solution or sodium hydroxide solution. Sterilize in an autoclave (at 121 °C \pm 2 °C for at least 15 min). After preparation, if 1/500 nutrient broth is not used immediately, store at 5 °C to 10 °C. Do not use 1/500 nutrient broth made more than a week ago.

6.2.3 Calcium solution

For 100 ml of purified water, take 3,0 g of calcium chloride dihydrate, put it in a flask, and dissolve it thoroughly. Add a cotton plug and sterilize in an autoclave (see [6.2.2](#)). After preparation, if calcium solution is not used immediately, store at 5 °C to 10 °C. Do not use the calcium solution made more than 6 months ago.

6.2.4 LB broth with calcium

For 1 000 ml of purified water, take 10,0 g of peptone, 5,0 g of yeast extract, and 10,0 g of sodium chloride, put them in a flask, and dissolve them thoroughly. When the contents are thoroughly dissolved, use a solution of sodium hydroxide or hydrochloric acid to bring the pH to $(7,0 \pm 0,2)$ at 25 °C. Add a cotton plug and sterilize in an autoclave (see [6.2.2](#)). After autoclaving, add 10 ml of calcium solution to medium and mix well. After preparation, if LB broth with calcium is not used immediately, store at 5 °C to 10 °C. Do not use the broth made more than 1 month ago.

6.2.5 Agar powder

Use agar powder for which the gel strength of 1,5 % agar is from 400 g/cm² to 600 g/cm².

6.2.6 LB agar

For 1 000 ml of purified water, take 10,0 g of peptone, 5,0 g of yeast extract, and 10,0 g of sodium chloride and 10,0 g of agar powder (see [6.2.5](#)), put them in a flask, and mix. Heat the flask in boiling water to dissolve the contents thoroughly. Use a 0,1 mol/l solution of sodium hydroxide to bring the pH to $(7,0 \pm 0,2)$ at 25 °C. Add a cotton plug and sterilize in an autoclave (see [6.2.2](#)). After preparation, if nutrient agar is not used immediately, store at 5 °C to 10 °C. Do not use nutrient agar made more than 1 month ago.

6.2.7 Bottom agar plate (LB agar plate with calcium)

For 1 000 ml of purified water, take 10,0 g of peptone, 5,0 g of yeast extract, and 10,0 g of sodium chloride and 15,0 g of agar powder (see [6.2.5](#)), put them in a flask, and mix. Heat the flask in boiling water to dissolve the contents thoroughly. Use a 0,1 mol/l solution of sodium hydroxide to bring the pH to $(7,0 \pm 0,2)$ at 25 °C. Add a cotton plug and sterilize in an autoclave (see [6.2.2](#)). After autoclaving, add 10 ml of calcium solution to medium and mix well. After preparation, pour 15 ml to 20 ml of medium into 90 mm diameter Petri dish, store at 5 °C to 10 °C. Do not use nutrient agar made more than 2 weeks ago.

6.2.8 Top agar

For 1 000 ml of purified water, take 15,0 g of peptone, 7,5 g of yeast extract, and 15,0 g of sodium chloride and 10,0 g of agar powder (see [6.2.5](#)), put them in a flask, and mix. Heat the flask in boiling water to dissolve the contents thoroughly. Use a 0,1 mol/l solution of sodium hydroxide to bring the pH to $(7,0 \pm 0,2)$ at 25 °C. Add a cotton plug and sterilize in an autoclave (see [6.2.2](#)). After autoclaving, add 15 ml of calcium solution to medium and mix well. After preparation, if top agar is not used immediately, store at 5 °C to 10 °C. Do not use nutrient agar made more than 1 month ago.

NOTE When the top agar is remelted, heat the flask in boiling water, but not autoclaving.

6.2.9 Soybean-casein digest broth with lecithin and polysorbate 80 (SCDLP)

For 1 000 ml of purified water, take 17,0 g of casein peptone, 3,0 g of soybean peptone, 5,0 g of sodium chloride, 2,5 g of dipotassium hydrogenphosphate, 2,5 g of glucose, 1,0 g of lecithin, put them into a flask, and dissolve them. Add 7,0 g of non-ionic surfactant and dissolve it. Use a solution of sodium hydroxide or hydrochloric acid to bring the pH of $(7,0 \pm 0,2)$ at 25 °C. If necessary, dispense it in a test tube, add a cotton plug, and sterilize in an autoclave (see [6.2.2](#)). After preparation, if SCDLP is not used immediately, store at 5 °C to 10 °C. Do not use SCDLP medium made more than 1 month ago.

6.2.10 Peptone saline solution

For 1 000 ml of purified water, take 10,0 g of peptone and 8,5 g of sodium chloride, put them into a flask and dissolve them thoroughly. When the contents are thoroughly diluted, use a solution of sodium hydroxide or hydrochloric acid to bring the pH to $(7,0 \pm 0,1)$ at 25 °C. If necessary, dispense it in a test tube and sterilize in an autoclave (see [6.2.2](#)). After preparation, if peptone saline solution is not used immediately, store at 5 °C to 10 °C. Do not use peptone saline solution made more than 1 month ago.

7 Apparatus and equipment

7.1 Test equipment

The test equipment enables a photocatalytic material to be examined for its antiviral activity by providing UV irradiation to activate the photocatalyst. It consists of a light source and the chamber with a test piece. A schematic of a testing equipment is shown in [Figure 1](#).

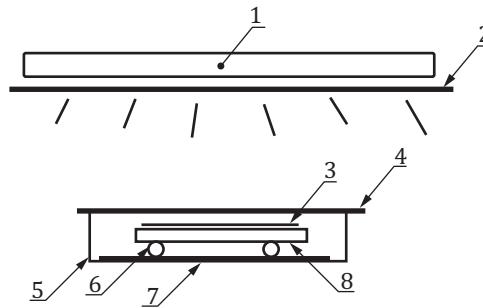

Key

- 1 light source
- 2 punched metal sheet
- 3 cover film
- 4 moisture preservation glass
- 5 Petri dish
- 6 glass tube or glass rod
- 7 paper filter
- 8 test piece

Figure 1 — Schematic of the testing equipment

7.2 Cover film

The cover film shall be used as specified in ISO 27447, 7.1. The sheets should be cut in a (40 ± 2) mm \times (40 ± 2) mm square. In case of irregularly sized test piece [see [Clause 8](#), item b), NOTE 1], prepare cover film with the same shape as the test piece but with dimensions 2,5 mm to 5 mm smaller than those of the test piece.

NOTE Reference data for cover films is given in ISO 27447, Annex B.

7.3 Moisture preservation glass plate

The moisture preservation glass plate shall be used as specified in ISO 27447, 7.2. The dimensions of the glass plates should be sufficient to fully cover Petri dishes.

NOTE Reference data for moisture preservation glasses is given in ISO 27447, Annex B.

7.4 Glass tube or glass rod

The glass tube or rod in an approximately 4 mm to 6 mm diameter should be prepared by cutting it to 10 cm to 15 cm in length and bending it into a U- or V-shape.

NOTE The glass tube or glass rod supports the test piece in the Petri dish.

7.5 Paper filter

The cellulose paper filter should be prepared by cutting it to approximately 85 mm in diameter.

NOTE One to four pieces of round-shaped cellulose paper filters per Petri dish are needed, depending on the amount of water absorption.

7.6 Fluorescent ultraviolet lamp

The fluorescent ultraviolet lamp shall be 351BLB or 351BL as specified in ISO 10677.

7.7 UV radiometer

The UV radiometer shall be used as specified in ISO 10677.

7.8 Punched metal sheet

When the prescribed intensity cannot be obtained by tuning the light-source height, attenuate the intensity by using a punched metal sheet (see [Figure 2](#) and [Figure 3](#)) directly below the lamp.

Dimensions in millimetres

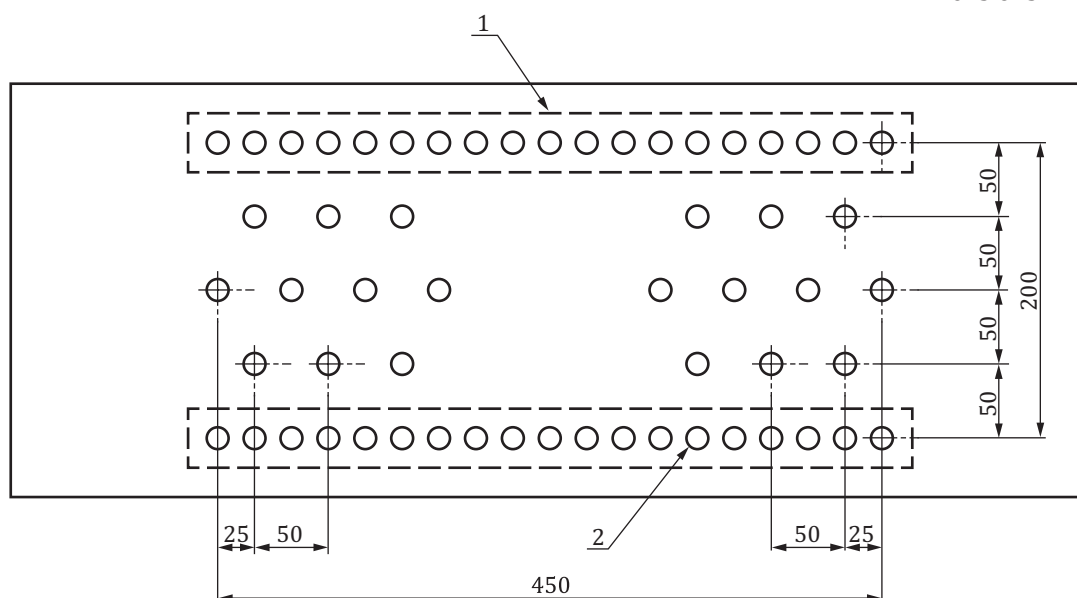

Key

- 1 lamp position
- 2 bore (diameter approximately 5 to 15)

Figure 2 — Punched metal sheet for 0,01 mW/cm² light intensity

Dimensions in millimetres

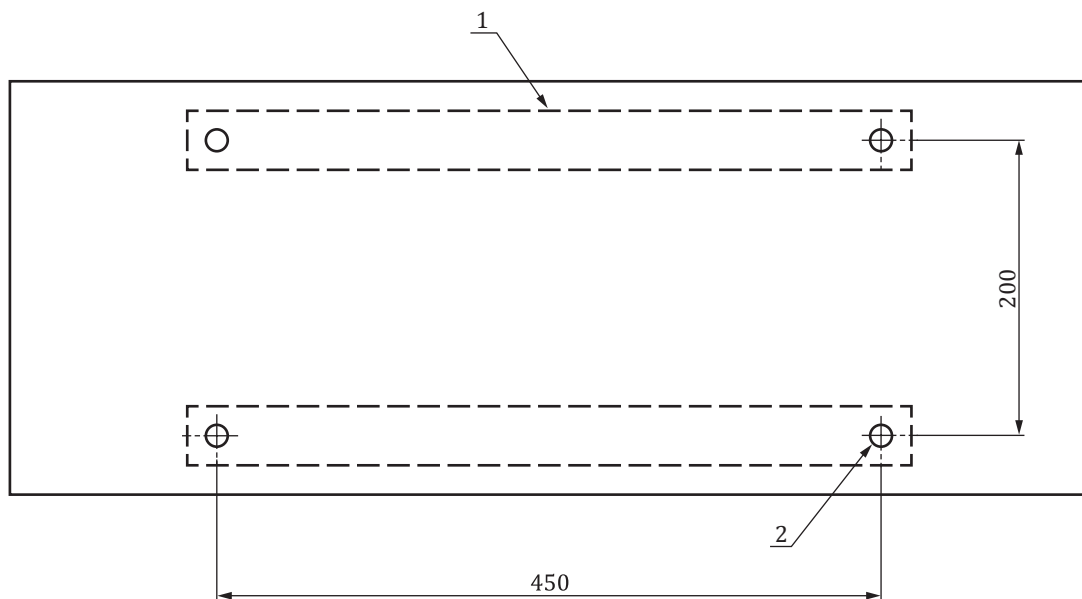

Key

- 1 lamp position
- 2 bore (diameter approximately 5 to 15)

Figure 3 — Punched metal sheet for 0,001 mW/cm² light intensity

7.9 Centrifuge

The centrifuge shall be capable of applying an acceleration of 10 000 *g* at (4 ± 2) °C.

7.10 Sterilized syringe filter unit

The filter of syringe filter units (pore size is 0,2 µm to 0,45 µm) shall be consisting of a polyethersulfone (PES) or polyvinylidene fluoride (PVDF).

NOTE Because of the adsorption, cellulose filter is not adequate.

8 Test piece

- a) Cut a flat portion of the material to be tested in a (50 ± 2) mm × (50 ± 2) mm square. The thickness of materials for test should not exceed 10 mm. Use it as the standardized shaped specimen.
- b) Prepare nine pieces of non-treated specimens and six pieces of photocatalytic-treated specimens. When non-treated specimens cannot be provided, use glass plates instead. Take great care to avoid microbial contamination and cross-contamination among specimens.

NOTE 1 When it is difficult or impossible to cut (50 ± 2) mm long (up to 10 mm thickness) squares, it is acceptable to use a test piece to be reduced to a size of 1/2 (up to 10 mm thickness).

NOTE 2 When the specimen surface is stained with organic contaminant, it is acceptable to first eliminate contaminant by exposure to a 1,0 mW/cm² light source within the limit of 24 h. If necessary, specimens can be disinfected prior to testing (e.g. wiping with ethanol or 70 % ethanol in water).

9 Procedure

9.1 General

The flowcharts of test methods are shown in [Figure 4](#).

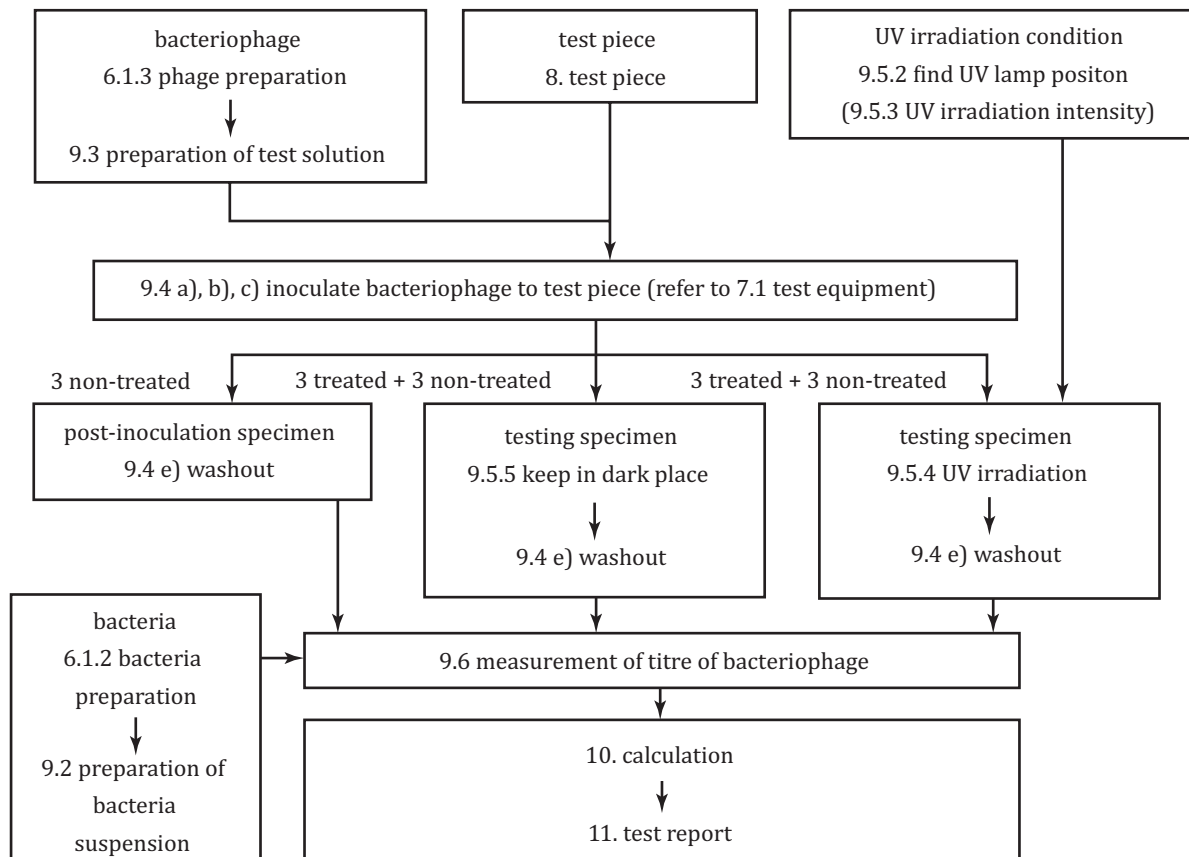

Figure 4 — Flowchart of film adhesion method

9.2 Procedure for preparation of bacteria suspension

- Transfer the stored bacteria (see [6.1.2](#)) to 3 ml of LB with calcium using a platinum loop.
- Incubate at $(37 \pm 1) ^\circ\text{C}$ for 16 h to 24 h.
- Transfer approximately 1/1000 of the incubated bacteria culture prepared under b) to LB with calcium.

NOTE 1 The volume of LB with calcium depends on the number of Petri dishes [see [9.6](#), item g)].

- Incubate at $(37 \pm 1) ^\circ\text{C}$ to a cell density of $5,0 \times 10^8$ cfu/ml to $2,0 \times 10^9$ cfu/ml.

NOTE 2 This procedure should be carried out several times to establish the relationship between turbidity measurements and colony counts. If sufficient data have been obtained, further work can be based on turbidity measurements only.

9.3 Procedure of preparation of test bacteriophage solution

- Dilute a bacteriophage stock solution (see [6.1.3](#)) with 1/500 NB to obtain a titre of $1,0 \times 10^7$ pfu/ml to $4,0 \times 10^7$ pfu/ml.

NOTE 1 The volume of LB with calcium depends on the number of Petri dishes [see 9.6, item g)].

NOTE 2 This procedure should be carried out without using a vortex mixer to avoid disappearing phage infectivity. Agitation using the hands is recommended.

- b) If the test bacteriophage suspension is not to be used immediately, store it at 0 °C and use it within 2 h.

9.4 Procedure of test for photocatalytic antiviral activity

- a) Lay a sterilized moisture control paper filter in the bottom of a sterilized Petri dish, add an adequate quantity of sterilized water, place a glass tube or glass rod on paper filter, and place the test piece on it with the photocatalytic treated surface up. Repeat this procedure for each of the photocatalytic treated and non-photocatalytic treated samples used in the test (six of the former and nine of the latter).

NOTE 1 In order to avoid contact between the test piece and the wetted paper filter, a glass tube or glass rod is used.

NOTE 2 In order to prevent the moisture conservation glass misting over, 4 ml to 6 ml sterilized water added per Petri dish is adequate.

- b) Collect 0,15 ml of test bacteriophage solution with a sterilized pipette and drip it onto each test piece. Put a film on top of the dripped solution and lightly push to get the solution spread to the whole film surface, while taking care that no solution leaks out of the film edge. In case of irregularly sized test piece [see Clause 8, item b), NOTE 1], adjust the inoculate volume of test bacteriophage solution to proportional to film size (see 7.2).

NOTE 3 The regulated solution quantity can create leakage of suspension from the film edge or might not be enough to spread the suspension uniformly. In such a case, it is acceptable to reduce down to half the quantity of suspension or increase to twice the quantity of suspension. However, even when the bacteriophage solution quantity for inoculation has been changed, the number of phages per specimen will be kept the same as with the standard size specimen, within a range of $1,0 \times 10^6$ pfu to $4,0 \times 10^6$ pfu.

NOTE 4 This procedure should be carried out without using vortex mixer to avoid disappearing phage infectivity. Agitation using the hands is recommended.

- c) Place a moisture conservation glass plate on the top of Petri dish.
- d) Except for three non-treated specimens for measurement of titre of bacteriophage (see 9.6) performed just after the test bacteriophage solution is inoculated, proceed with irradiation test described in 9.5.
- e) For the three non-treated test bacteriophage solution inoculated specimens for the test (post-inoculation specimen of test bacteriophage solution), put the cover film and non-treated test piece in a Stomacher bag using sterilized tweezers, taking care to avoid test bacteriophage solution leakage from the film and non-treated test piece. Add 10 ml of SCDLP, rub the specimens and the film well from outside of the Stomacher bag by hands and washout the test bacteriophage solution. Quickly use this washout solution to perform a measurement of titre of bacteriophage (see 9.6).

NOTE 5 Alternative equivalents of the Stomacher bag may be used if they can be shown to lead to the same results.

9.5 UV irradiation condition

- 9.5.1 Keep the temperature around specimens at $25 \text{ °C} \pm 5 \text{ °C}$ in 9.5.4 and 9.5.5.

9.5.2 Set the photoelectric sensor of a UV radiometer on the base of the irradiation apparatus. Place the film and glass plate used for testing on top of the sensor. Find the positions where the UV intensity referred to in 9.5.3 is complied with, with reading the indicator value.

9.5.3 Test the UV intensity condition, depending on the circumstances where the materials are used. When the prescribed UV intensity cannot be obtained by tuning the height of the light source, attenuate the intensity by using a punched metal sheet.

Table 2 — UV irradiation intensity to be referred to in test

UV intensity	Example
0,25 mW/cm ²	Beside the window in the daytime, beside the assistant lamp for photocatalytic reaction (e.g. BLB)
0,10 mW/cm ²	In the room (inside about 1,5 m from the window) in the daytime, by the window in the early morning or before sunset
0,01 mW/cm ²	In the room (inside about 3 m from the window) in the daytime
0,001 mW/cm ²	In the room without window (only indoor light), in the room at night (only indoor light)

NOTE 1 The maximum UV intensity is 0,25 mW/cm² to avoid damage by UV irradiation only. The minimum UV intensity of the photoelectric sensor at present is 0,001 mW/cm².

9.5.4 Expose to light the Petri dishes containing the specimens (three non-treated specimens and three photocatalytic treated specimens) with test bacteriophage solution for 4 h.

NOTE 2 This exposure time can be changed from 2 h to 8 h to take into account the real conditions where the photocatalyst material is effectively used.

9.5.5 Keep the Petri dishes containing the specimens (three non-treated specimens and three photocatalytic treated specimens) with test bacteriophage solution in a dark place, for the same time as in [9.5.4](#).

9.5.6 As for the specimens of [9.5.4](#) and [9.5.5](#), perform the washout in the same manner in [9.4 e](#)).

9.6 Measurement of titre of bacteriophage

- a) Melt bottles of top agar, cool to approximately 50 °C, and distribute 2,0 ml aliquots into culture tubes with caps, placed in a water bath at (45 ± 1) °C.
- b) Pre-warm the bottom agar plate at (37 ± 1) °C.
- c) Take 1 ml of washout solution {or stock solution [see [9.3 a](#)]} with a sterilized pipette. Add to (9 ± 0,1) ml of peptone saline solution in a test tube. Agitate thoroughly and gently without using the vortex mixer.

NOTE 1 This procedure should be carried out without using vortex mixer to avoid disappearing phage infectivity. Agitation using the hands is recommended.

NOTE 2 If the washout solution and diluted solution are not to be infected with *E. coli* immediately, store washout solution at 0 °C. Dilute and infect them with *E. coli* within 2 h.

- d) Extract 1 ml of the solution [above c)] with a new sterilized pipette. Add to another test tube containing (9 ± 0,1) ml of peptone saline solution. Agitate thoroughly and gently again.
- e) Repeat to obtain series of dilutions, in compliance with the 10-time dilution method.
- f) Pre-warm the solution [washout solution, above c), d), and e)] at (37 ± 1) °C for 10 min.
- g) Add 0,1 ml of bacteria suspension [see [9.2 d](#))] into the culture tube [above a)] and mix gently without using the vortex mixer.

NOTE 3 This procedure should be carried out without using the vortex mixer to avoid disappearing phage sensitivity of *E. coli*. Agitation using the hands is recommended.

- h) Add 1 ml of solution [above f)] into the culture tube [above g)] and mix gently without using the vortex mixer.
- i) Pour the contents [above h)] over the surface of a pre-warmed bottom agar plate [above b)]. Examine each washout solution or diluted solution in duplicate.
- j) Allow them to stand for 15 min to 30 min at room temperature.
- k) Incubate the Petri dishes for $18 \text{ h} \pm 2 \text{ h}$ at $(37 \pm 1) \text{ }^\circ\text{C}$, after the top agar solidifies.
- l) Count the number of plaques appearing on the series of Petri dishes with 30 colonies to 300 colonies.

10 Calculation

10.1 General

The test results are calculated as follows. The calculated values shall be rounded to the second decimal place in accordance with ISO 80000-1.

NOTE Example of test results are given in [Annex A](#).

10.2 Calculate titre of bacteriophage

Apply Formula (1) to calculate the titre of bacteriophage. When the number of plaques is less than 30 in the Petri dishes with 1 ml of washout solution, the plaque number is used to calculate the average number. When the number of plaque is less than 1 in the Petri dishes with 1 ml of washout solution, the average number is taken as 1.

$$N = Z \times D_F \times 10 \quad (1)$$

where

N is titre of bacteriophage (pfu);

Z is the average number of plaques in two Petri dishes (pfu/ml);

D_F is the dilution factor;

10 is the volume of SCDLP medium for washout (ml).

10.3 Test requirement fulfilment validation

A test is considered valid if it fulfils all of the following four items. If one or more of these items are not fulfilled, the test is considered as not valid and shall be performed again.

- a) The logarithmic value of the number of titre of bacteriophage of non-treated specimens after inoculation is derived from Formula (2).

$$(Log_{\max} - Log_{\min}) / (Log_{\text{mean}}) \leq 0,2 \quad (2)$$

where

Log_{\max} is the maximum logarithmic value of titre of bacteriophage;

Log_{\min} is the minimum logarithmic value of titre of bacteriophage;

Log_{mean} is the average logarithmic value of titre of bacteriophage for three specimens.

- b) The titre of bacteriophage of non-treated specimens after inoculation shall be within the $1,0 \times 10^6$ to $4,0 \times 10^6$ pfu range.
- c) The titre of bacteriophage of non-treated specimens after light exposure shall be more than $1,0 \times 10^4$ pfu for all three specimens. However, when a glass plate is used as the non-treated specimen, the titre of bacteriophage after light exposure shall be more than $1,0 \times 10^5$ pfu.
- d) After being kept in a dark place, the titre of bacteriophage of non-treated specimens shall be more than $1,0 \times 10^4$ pfu for all three specimens. However, when a glass plate is used as the non-treated specimen, the titre of bacteriophage after light exposure shall be more than $1,0 \times 10^5$ pfu.

10.4 Photocatalyst antiviral activity value calculation

Use Formulae (3) and (4) to calculate the photocatalyst antiviral activity value after the test is completed.

$$V_L = [\log(B_L / A) - \log(C_L / A)] = \log[B_L / C_L] \quad (3)$$

where

V_L is the photocatalyst antiviral activity value, after UV irradiation of intensity L ;

L is the UV irradiation intensity (mW/cm²);

A is the average of titre of bacteriophage of non-treated specimens, just after inoculation;

B_L is the average of titre of bacteriophage of non-treated specimens, after UV irradiation of intensity L ;

C_L is the average of titre of bacteriophage of photocatalytic treated specimens, after UV irradiation of intensity L .

$$\Delta V = \log[B_L / C_L] - [\log(B_D / A) - \log(C_D / A)] = \log[B_L / C_L] - \log[B_D / C_D] \quad (4)$$

where

ΔV is the photocatalyst antiviral activity value with UV irradiation;

B_D is the average of titre of bacteriophage of non-treated specimens, after being kept in a dark place;

C_D is the average of titre of bacteriophage of photocatalytic treated specimens, after being kept in a dark place.

10.5 Antiviral activity value calculation without photocatalyst

In case of including antiviral materials without photocatalyst, use Formulae (5) to calculate the antiviral activity value without photocatalyst after the test is completed.

$$V_D = [\log(B_D / C_D)] \quad (5)$$

where

V_D is the antiviral activity value without photocatalyst, after being kept in a dark place on a testing material;

B_D is the average of titre of bacteriophage of non-treated specimens, after being kept in a dark place;

C_D is the average of titre of bacteriophage of photocatalytic treated specimens, after being kept in a dark place.

11 Test report

The test report shall include the following information:

- a) a reference to this test method;
- b) description of the type, size, shape, and thickness of the photocatalyst and non-treated specimens;
- c) description of conditions of pre-exposure (see [Clause 8](#) NOTE 2) when applied;
- d) type of test strains number;
- e) manufacturer of fluorescent UV lamp and product number;
- f) manufacturer of ultraviolet light radiometer and product number;
- g) light exposure conditions including UV irradiation intensity and light exposure duration;
- h) type and size of cover film and moisture preservation glass;
- i) quantity of inoculated test solution, titre of bacteriophage of test solution;
- j) values of A , B_L , C_L , V_L , B_D , C_D , ΔV ;
- k) in case of including antiviral materials without photocatalyst, values of A , B_L , C_L , V_L , B_D , C_D , ΔV , V_D .

Annex A (informative)

Reference data of comparison between influenza virus and bacteriophage Q-beta

The comparison of photocatalytic activity between influenza virus and bacteriophage Q-beta is evaluated with TiO₂ sample. The results are shown in [Figure A.1](#) and [Figure A.2](#).

NOTE Bacteriophage Q-beta was suspended in 1/500 NB. Influenza A virus was suspended in phosphate buffered saline (PBS) supplemented with 0.2 mg/ml bovine serum albumin (BSA) to keep its activity.

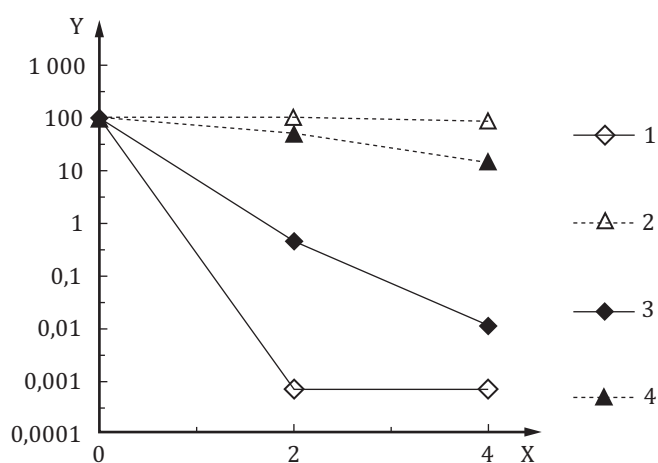

Key

- X irradiation time (h)
- Y relative ratio to initial infectivity titre
- 1 bacteriophage, sample B
- 2 bacteriophage, glass plate
- 3 Influenza A virus, sample B
- 4 Influenza A virus, glass plate

Figure A.1 — Comparison of photocatalytic activity between influenza A virus and bacteriophage Q-beta (0,10mW/cm²)

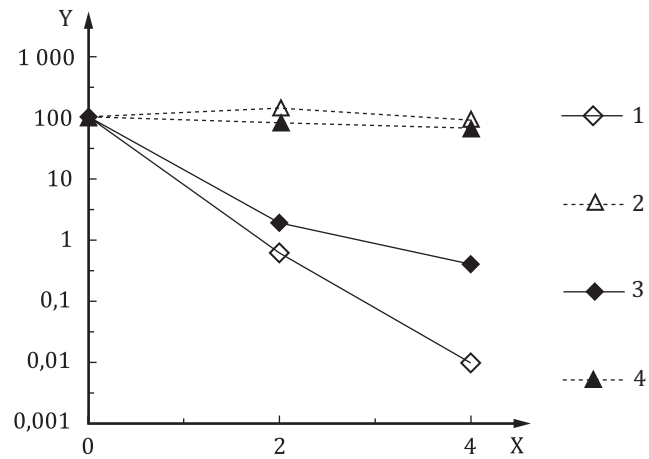

Key

- X irradiation time (h)
- Y relative ratio to initial infectivity titre
- 1 bacteriophage, sample B
- 2 bacteriophage, glass plate
- 3 Influenza A virus, sample B
- 4 Influenza A virus, glass plate

Figure A.2 — Comparison of photocatalytic activity between influenza A virus and bacteriophage Q-beta (0,01mW/cm²)

Annex B (informative)

Comparison of photocatalytic activities determined using ATCC23631-B1 and NBRC20012

The sensitivity to photocatalytic activity of bacteriophage Q-beta (ATCC23631-B1 and NBRC20012) is evaluated with TiO₂ sample. The results are shown in [Figure B.1](#) and [Figure B.2](#).

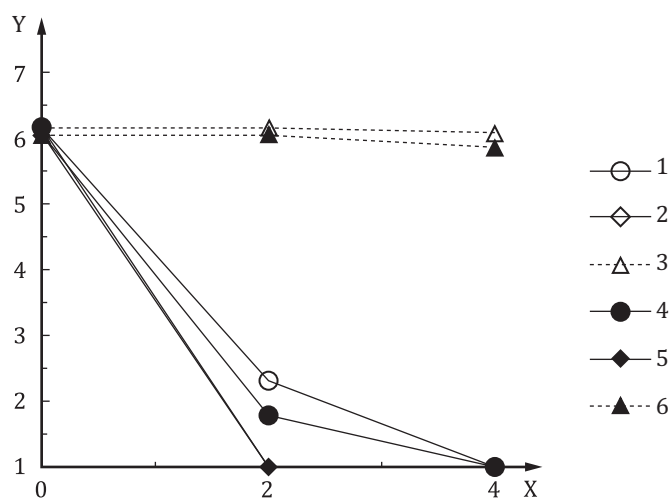

Key

- X irradiation time (h)
- Y titre of bacteriophage (log₁₀)
- 1 NBRC, sample A
- 2 NBRC, sample B
- 3 NBRC, glass plate
- 4 ATCC, sample A
- 5 ATCC, sample B
- 6 ATCC, glass plate

Figure B.1 — Comparison of photocatalytic activity between ATCC23631-B1 and NBRC20012 (0,10mW/cm²)

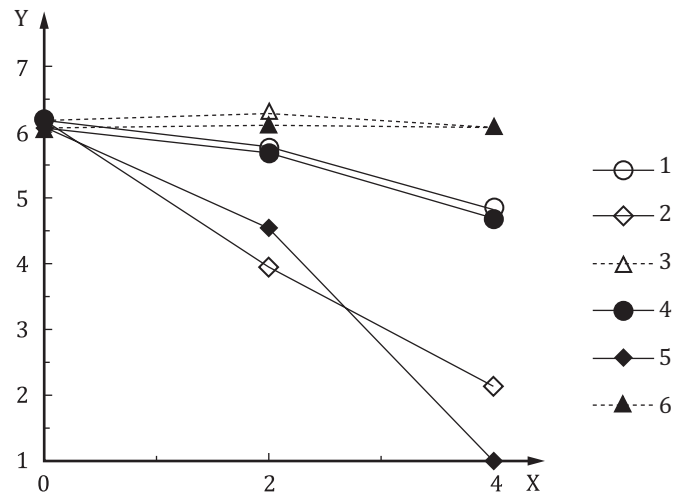

Key

- X irradiation time (h)
- Y titre of bacteriophage (\log_{10})
- 1 NBRC, sample A
- 2 NBRC, sample B
- 3 NBRC, glass plate
- 4 ATCC, sample A
- 5 ATCC, sample B
- 6 ATCC, glass plate

Figure B.2 — Comparison of photocatalytic activity between ATCC23631-B1 and NBRC20012 (0,01mW/cm²)

British Standards Institution (BSI)

BSI is the national body responsible for preparing British Standards and other standards-related publications, information and services.

BSI is incorporated by Royal Charter. British Standards and other standardization products are published by BSI Standards Limited.

About us

We bring together business, industry, government, consumers, innovators and others to shape their combined experience and expertise into standards-based solutions.

The knowledge embodied in our standards has been carefully assembled in a dependable format and refined through our open consultation process. Organizations of all sizes and across all sectors choose standards to help them achieve their goals.

Information on standards

We can provide you with the knowledge that your organization needs to succeed. Find out more about British Standards by visiting our website at bsigroup.com/standards or contacting our Customer Services team or Knowledge Centre.

Buying standards

You can buy and download PDF versions of BSI publications, including British and adopted European and international standards, through our website at bsigroup.com/shop, where hard copies can also be purchased.

If you need international and foreign standards from other Standards Development Organizations, hard copies can be ordered from our Customer Services team.

Subscriptions

Our range of subscription services are designed to make using standards easier for you. For further information on our subscription products go to bsigroup.com/subscriptions.

With **British Standards Online (BSOL)** you'll have instant access to over 55,000 British and adopted European and international standards from your desktop. It's available 24/7 and is refreshed daily so you'll always be up to date.

You can keep in touch with standards developments and receive substantial discounts on the purchase price of standards, both in single copy and subscription format, by becoming a **BSI Subscribing Member**.

PLUS is an updating service exclusive to BSI Subscribing Members. You will automatically receive the latest hard copy of your standards when they're revised or replaced.

To find out more about becoming a BSI Subscribing Member and the benefits of membership, please visit bsigroup.com/shop.

With a **Multi-User Network Licence (MUNL)** you are able to host standards publications on your intranet. Licences can cover as few or as many users as you wish. With updates supplied as soon as they're available, you can be sure your documentation is current. For further information, email bsmusales@bsigroup.com.

BSI Group Headquarters

389 Chiswick High Road London W4 4AL UK

Revisions

Our British Standards and other publications are updated by amendment or revision.

We continually improve the quality of our products and services to benefit your business. If you find an inaccuracy or ambiguity within a British Standard or other BSI publication please inform the Knowledge Centre.

Copyright

All the data, software and documentation set out in all British Standards and other BSI publications are the property of and copyrighted by BSI, or some person or entity that owns copyright in the information used (such as the international standardization bodies) and has formally licensed such information to BSI for commercial publication and use. Except as permitted under the Copyright, Designs and Patents Act 1988 no extract may be reproduced, stored in a retrieval system or transmitted in any form or by any means – electronic, photocopying, recording or otherwise – without prior written permission from BSI. Details and advice can be obtained from the Copyright & Licensing Department.

Useful Contacts:

Customer Services

Tel: +44 845 086 9001

Email (orders): orders@bsigroup.com

Email (enquiries): cservices@bsigroup.com

Subscriptions

Tel: +44 845 086 9001

Email: subscriptions@bsigroup.com

Knowledge Centre

Tel: +44 20 8996 7004

Email: knowledgecentre@bsigroup.com

Copyright & Licensing

Tel: +44 20 8996 7070

Email: copyright@bsigroup.com



...making excellence a habit.™