

BS ISO 17972-4:2015



BSI Standards Publication

Graphic technology — Colour data exchange format (CxF/X)

Part 4: Spot colour characterisation data (CxF/X-4)

bsi.

...making excellence a habit.™

National foreword

This British Standard is the UK implementation of ISO 17972-4:2015.

The UK participation in its preparation was entrusted to Technical Committee PAI/43, Graphic technology.

A list of organizations represented on this committee can be obtained on request to its secretary.

This publication does not purport to include all the necessary provisions of a contract. Users are responsible for its correct application.

© The British Standards Institution 2015. Published by BSI Standards Limited 2015

ISBN 978 0 580 82182 0

ICS 35.240.30; 37.100.99

Compliance with a British Standard cannot confer immunity from legal obligations.

This British Standard was published under the authority of the Standards Policy and Strategy Committee on 31 July 2015.

Amendments issued since publication

Date	Text affected
------	---------------

INTERNATIONAL
STANDARD

ISO
17972-4

First edition
2015-06-15

**Graphic technology — Colour data
exchange format (CxF/X) —**

Part 4:
**Spot colour characterisation data
(CxF/X-4)**

*Technologie graphique — Échange des données de couleur en
utilisant CxF —*

Partie 4: Données de caractérisation des points de couleur



Reference number
ISO 17972-4:2015(E)



COPYRIGHT PROTECTED DOCUMENT

© ISO 2015, Published in Switzerland

All rights reserved. Unless otherwise specified, no part of this publication may be reproduced or utilized otherwise in any form or by any means, electronic or mechanical, including photocopying, or posting on the internet or an intranet, without prior written permission. Permission can be requested from either ISO at the address below or ISO's member body in the country of the requester.

ISO copyright office
Ch. de Blandonnet 8 • CP 401
CH-1214 Vernier, Geneva, Switzerland
Tel. +41 22 749 01 11
Fax +41 22 749 09 47
copyright@iso.org
www.iso.org

Contents

	Page
Foreword	iv
Introduction	v
1 Scope	1
2 Terms and definitions	1
3 Symbols and abbreviated terms	2
4 Requirements	2
4.1 Conformance levels.....	2
4.2 Characterisation chart preparation.....	3
4.2.1 General.....	3
4.2.2 Printed patches.....	3
4.2.3 Substrate and ink identification.....	4
4.2.4 Preparation of black region.....	4
4.2.5 Measurements.....	4
4.3 Measurement communication.....	4
4.3.1 General.....	4
4.3.2 Structure.....	4
4.3.3 FileInformation element.....	5
4.3.4 Core Resources.....	5
4.3.5 CustomResources.....	7
Annex A (normative) XML schema for CxF/X-4 CustomResource	9
Annex B (informative) Examples of CxF/X-4 documents	10
Annex C (informative) CxF Core schema	11
Bibliography	12

Foreword

ISO (the International Organization for Standardization) is a worldwide federation of national standards bodies (ISO member bodies). The work of preparing International Standards is normally carried out through ISO technical committees. Each member body interested in a subject for which a technical committee has been established has the right to be represented on that committee. International organizations, governmental and non-governmental, in liaison with ISO, also take part in the work. ISO collaborates closely with the International Electrotechnical Commission (IEC) on all matters of electrotechnical standardization.

The procedures used to develop this document and those intended for its further maintenance are described in the ISO/IEC Directives, Part 1. In particular the different approval criteria needed for the different types of ISO documents should be noted. This document was drafted in accordance with the editorial rules of the ISO/IEC Directives, Part 2 (see www.iso.org/directives).

Attention is drawn to the possibility that some of the elements of this document may be the subject of patent rights. ISO shall not be held responsible for identifying any or all such patent rights. Details of any patent rights identified during the development of the document will be in the Introduction and/or on the ISO list of patent declarations received (see www.iso.org/patents).

Any trade name used in this document is information given for the convenience of users and does not constitute an endorsement.

For an explanation on the meaning of ISO specific terms and expressions related to conformity assessment, as well as information about ISO's adherence to the WTO principles in the Technical Barriers to Trade (TBT) see the following URL: [Foreword - Supplementary information](#)

The committee responsible for this document is ISO/TC 130, *Graphic technology*.

ISO 17972 consists of the following parts, under the general title *Graphic technology — Colour data exchange format (CxF/X)*:

- *Part 1: Relationship to CxF3 (CxF/X)*
- *Part 4: Spot colour characterisation data (CxF/X-4)*

The following parts are under preparation:

- *Part 2: Scanner target data (CxF/X-2)*
- *Part 3: Output target data (CxF/X-3)*

Introduction

ISO 17972 (all parts) defines methods for the exchange of measurement data and associated metadata within the graphic arts industry and for the exchange of files between graphic arts users. It is a multi-part document where each part is intended to respond to different workflow requirements. The goal throughout the various parts of ISO 17972 has been to maintain the degree of flexibility required while minimizing the uncertainty of the data exchanged.

ISO 17972-1 defines the use of the publicly available Color Exchange Format, version 3 (CxF3), for prepress data exchange and verification.

ISO 17972-2 defines the use of a CustomResource for the creation of scanner target data.

ISO 17972-3 defines the use of a CustomResource when exchanging data from ISO 12642-1 and ISO 12642-2, Prepress digital data exchange — Colour targets — Input data for characterization of 4-colour process printing.

Communication of printing characteristics of inks is essential in order to ensure that a printed product has the appearance desired by a print buyer or brand manager. Traditionally, inks are thought of as being either process inks or spot inks. The term “process inks” is used to describe a set of inks that are frequently used in combination on a printing press (often cyan, magenta, yellow and black). Process inks are generally characterised in combination and the measurement data for combinations of inks is the subject of ISO 17972-3.

This part of ISO 17972 covers the use of CxF when exchanging spot colour characterisation data. There are many proprietary formats for this communication and it is hoped that this part of ISO 17972 will provide a more reliable means for the communication of spot colour characterisation data. It is usually impractical to print and measure combinations of spot colour inks, and instead, each ink is characterised in conjunction with a print substrate by means of its spectral characteristics and ink opacity.

In some cases, multiple impressions of single or multiple spot inks can be used and the details of the inks used and the production method are not provided in this part of ISO 17972. Similarly, the way in which an ink is produced is also outside of the scope. Information of this kind can be included using standard CxF extension mechanisms.

The measurement data for metallic and fluorescent colours as described in this part of ISO 17972 might not be sufficient to fully characterise these types of ink.

X-Rite Inc., the original creator of the CxF file format, claims no intellectual property rights to the materials used in this part of ISO 17972.

Graphic technology — Colour data exchange format (CxF/X) —

Part 4: Spot colour characterisation data (CxF/X-4)

1 Scope

This part of ISO 17972 defines an exchange format for spectral measurement data of inks to provide a means to characterise spot colour inks to allow reliable printing and proofing of products that have been designed using these inks. Only isotropic (paper-like) substrates are within the scope of this part of ISO 17972 which is limited to application areas where the same ink and paper combination that has been characterised is used when printing.

This part of ISO 17972 describes the use of a CustomResource element within the CxF framework to define a minimum and recommended set of data for exchange.

2 Terms and definitions

For the purposes of this document, the following terms and definitions apply.

2.1

ColorSpecification

information about the *ColorValue* (2.2) including its source (measurement specifications), illuminant/observer calculation method (tristimulus specifications), and physical attributes of the *objects* (2.5) (size, quantity, finish, etc.)

[SOURCE: ISO 17972-1, 3.1.1]

2.2

ColorValue

one of a number of defined colour space types that can hold values and associated information related to that specific type of device independent colour space

[SOURCE: ISO 17972-1, 3.1.2]

2.3

CustomResources

“extensible” part of CxF3; additional information not included in the CxF3 Core about colour objects and the file itself that is considered application specific in nature and not generally of use to all other applications

[SOURCE: ISO 17972-1, 3.1.3]

2.4

element content

XML text between the start-tag and end-tag of an element

[SOURCE: ISO 16684-1:2012, 3.2]

2.5

object

used to identify each specific “colour item” that is being described

[SOURCE: ISO 17972-1, 3.1.5]

2.6

resources

information about each colour object that is of interest to all readers of the CxF file

Note 1 to entry: This is also referred to as the “CxF3 Core”. It is defined by the CxF3-Core namespace schema.

[SOURCE: ISO 17972-1, 3.2.4]

2.7

schema

XML document conforming to the specifications established by the World Wide Web Consortium, that defines the structure of a class of XML documents

[SOURCE: ISO 17972-1, 3.2.5]

2.8

spot colour

non-process colour that is used in addition to, or in place of, a process colour and is normally applied with a single impression

2.9

tint value

value usually in the range 0 to 1 that indicates how much of a marking substance (e.g. ink, toner) should be applied to a printed region

Note 1 to entry: This is often referred to as tone value.

2.10

XML

eXtensible Markup Language
set of rules for encoding documents electronically

[SOURCE: ISO 17972-1:2015, 3.2.6 modified]

3 Symbols and abbreviated terms

The following documentation conventions are used.

- Names of XML elements are shown in bold type, for example, **Resources**.
- Names of XML attributes are shown in italics, for example, *SpotColorName*.
- XML XPath expressions are used to identify XML elements. For example, **container/contained** refers to an element (**contained**) that is a child of another element (**container**).
- Similarly, XML XPath expressions are used to refer to XML attributes, for example, **element1/@Name** refers to an attribute (*Name*) of an element (**element1**).

4 Requirements

4.1 Conformance levels

This specification defines three conformance levels identified as CxF/X-4, CxF/X-4a and CxF/X-4b. These conformance levels allow different methods of spot colour communication in common use to be described.

- a) CxF/X-4 Full Characterisation. The data provided by CxF/X-4 allows the colour and opacity of the ink to be specified. This is particularly important in situations where an accurate proof of the spot ink printed on top of other content is to be made.

- b) CxF/X-4a Single Background Characterisation. There are situations where it is useful to be able to communicate characterisation data for an ink where the ink will only be printed on a single background and so can be characterised using a single set of spectral measurements.
- c) CxF/X-4b Single Patch Characterisation. There are situations where it is useful to be able to communicate characterisation data for an ink where the ink will always be printed as a solid and so can be characterised using a single spectral measurement.

4.2 Characterisation chart preparation

4.2.1 General

Measurement data in a conforming CxF/X-4 file should be taken from a spot ink characterisation chart as shown in [Figure 1](#). This measurement data provides the characteristic colour response for the combination of ink and substrate.

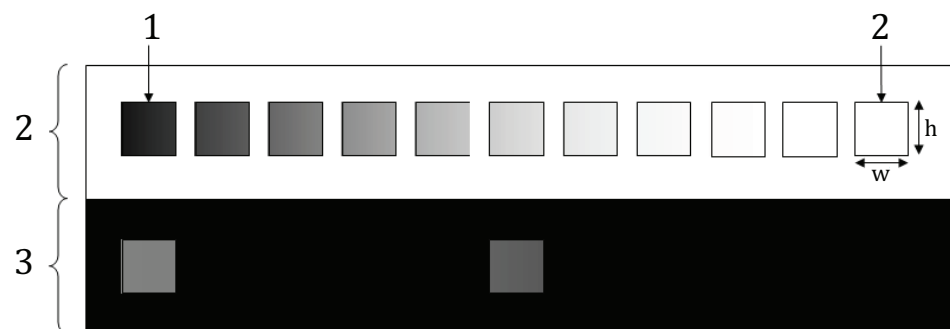

Key

- 1 solid
- 2 substrate
- 3 region printed with black

Figure 1 — Example characterisation chart

4.2.2 Printed patches

For all conformance levels, patches of 0 % and 100 % shall be printed on the unmarked substrate.

The printing system to be characterised shall be suitably configured and calibrated to match normal operating conditions before the characterisation chart is printed.

Tint levels recorded in the CxF data shall be those requested by the characterisation chart, which is not guaranteed to match the percentage area covered on the print because of tone value increase or other factors.

Tint levels recorded in the CxF data shall be as percentage values in the range of 0 to 100, where 0 means no ink was requested and 100 means that the chart requested that the area be completely covered with ink.

For conformance levels CxF/X-4 and CxF/X-4a, sets of patches shall include at least one patch with an intermediate tint level, for example 50 %, and should include a minimum of eleven patches in total.

For conformance level CxF/X-4, a second set of patches shall be printed on the region printed with black ink. This set of patches shall include 0 % and 100% tint levels and should include 50% tint level.

This part of ISO 17972 does not provide guidance as to how to measure patches and users shall ensure that measurements are made in line with measurement instrument manufacturer’s guidelines.

NOTE For most spot measurement systems, a patch width (w) and height (h) of 1 mm larger than the aperture size of the measuring device is a minimum requirement. See ISO 13655 for additional guidance.

The only difference in the ink characterisation data files for these conformance levels is the number and type of measurements required and this is shown in [Table 1](#) below.

Table 1 — Patch measurements required for each conformance level

Type of measurement	CxF/X-4	CxF/X-4a	CxF/X-4b
Solid ink printed on substrate	Required	Required	Required
Tints of ink printed on substrate	3 minimum, 11 recommended	3 minimum, 11 recommended	No requirement
Tints of ink printed on black background	3 minimum	No requirement	No requirement

4.2.3 Substrate and ink identification

The substrate and ink combination to be characterised shall each be identified by a unique name.

4.2.4 Preparation of black region

A region of the substrate shall be printed with a black ink. The resulting colour L^* value should be less than 20 and shall be as dark as possible. Its a^* and b^* values shall not be greater than 3 and shall not be less than -3.

NOTE This range [-3 3] might be insufficient for some inks, and in addition, the black region has to be spectrally non-selective.

The black ink should be completely dry before the spot ink patches are printed.

4.2.5 Measurements

Measurements of each patch shall be made using the same measurement condition.

The measurement condition used when making measurements shall be reported as described in [4.3.4.3](#).

4.3 Measurement communication

4.3.1 General

The characterisation chart shall be measured and the measurements and required metadata shall be communicated using CxF as specified in this section of this part of ISO 17972.

4.3.2 Structure

The document structure shall conform to the requirements of CxF 3.0 which has the form illustrated in [Figure 2](#).

The **FileInformation** and **Resources** elements shall conform to the CxF 3.0 requirements for core resources and in addition shall conform to requirements defined in this part of ISO 17972.

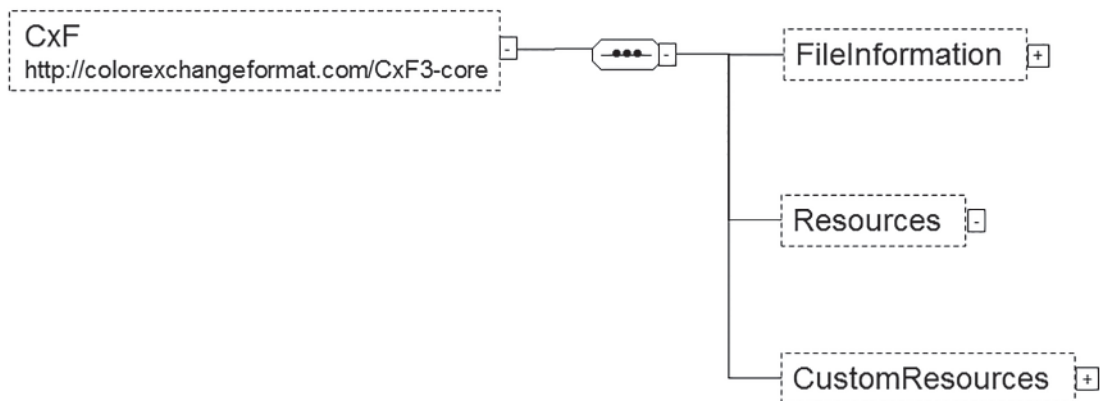

Figure 2 — Structure of a CxF document

4.3.3 FileInformation element

A single **FileInformation** element shall be included and shall include the following attributes as defined by the CxF core.

- **FileInformation**/*@Creator* shall be specified and shall indicate the person, organisation or software that created the measurement data.
- **FileInformation**/*@CreationDate* shall be specified and shall indicate the date and time at which the measurements were made.
- **FileInformation**/*@Description* shall be included and shall start with the string “CxF/X”. Where the file is to be used in compliance with another ISO standard, it shall include the standard number in the comment text.

4.3.4 Core Resources

4.3.4.1 Resources element

The **Resources** element shall include a set of **ReflectanceSpectrum** elements and an associated **ColorSpecification** element as shown below.

EXAMPLE The following example shows the structure of CxF Resources.

```

<Resources>
  <ObjectCollection>
    <Object ObjectType="Standard" Name="Red Spot" Id="A1">
      <ColorValues>
        <ReflectanceSpectrum ColorSpecification="CS001"
          Name="UniqueWithinThisObject">
          0.2852 0.3651 0.5526 0.7825 0.9326 0.9829 1.0031 1.0097 1.0059
          0.9989 0.9982 1.0019 1.0025 0.9954 0.9871 0.9794 0.9792 0.9805
          0.9766 0.9780 0.9754 0.9719 0.9691 0.9708 0.9753 0.9815 0.9893
          0.9940 0.9963 0.9952 0.9951 0.9928 0.9974 0.9997 1.0037 1.0137
        </ReflectanceSpectrum>
      </ColorValues>
    </Object>

    +++ other Object elements +++
  </ObjectCollection>

  <ColorSpecificationCollection>
    <ColorSpecification Id="CS001">
      <MeasurementSpec>
        <MeasurementType>Spectrum_Reflectance</MeasurementType>
      </MeasurementSpec>
    </ColorSpecification>
  </ColorSpecificationCollection>
</Resources>
  
```

```
<GeometryChoice>
  <SingleAngle>
    <SingleAngleConfiguration>Annular</SingleAngleConfiguration>
    <IlluminationAngle>45.0</IlluminationAngle>
    <MeasurementAngle>0.0</MeasurementAngle>
  </SingleAngle>
</GeometryChoice>
<WavelengthRange StartWL="380" Increment="10"/>
</MeasurementSpec>
</ColorSpecification>
</ColorSpecificationCollection>
```

</Resources>

4.3.4.2 ReflectanceSpectrum element

ReflectanceSpectrum/@ColorSpecification shall reference a **ColorSpecification** element. The associated **ColorSpecification** element shall describe the spectral measurements and shall conform to the requirements specified in section [4.3.4.3](#).

NOTE This referencing is achieved by ensuring that the value of **ReflectanceSpectrum/@ColorSpecification** is the same as the value **ColorSpecification/@Id** of the referenced **ColorSpecification**.

ReflectanceSpectrum/@Name shall be specified when multiple **ReflectanceSpectrum** elements are included in an **Object**. The *Name* attributes of all **ReflectanceSpectrum** included in an **Object** shall all have different values.

The **ReflectanceSpectrum** element content shall be a set of measurement data. This data should be spectral reflectance measurements from 360 nm to 780 nm but shall at least define spectral reflectance measurements from 400 nm to 700 nm, inclusive. The number of measurements required depends on *StartWL* and *Increment* attributes of the associated **ColorSpecification**.

The CxF Specification permits measurement data to be provided in a number of different forms. If additional forms of measurement data are included, they shall be consistent with the spectral reflectance data.

4.3.4.3 ColorSpecification element

The **ColorSpecification** element associated with a **ReflectanceSpectrum** shall be used to interpret the measurement data and shall include the elements and attributes as defined in this clause.

MeasurementSpec/MeasurementType shall be present and shall have the content *Spectrum_Reflectance*.

MeasurementSpec/Devicellumination shall be present and shall indicate the illumination source of the measuring instrument and shall have the content *M0_Incandescent*, *M1_Daylight*, *M2_UVExcluded* or *M3_Polarized*.

MeasurementSpec/GeometryChoice shall be present and shall include either a **SingleAngle** or a **SphereGeometry** element.

When a **SingleAngle** element is used, it shall include the following elements:

- **SingleAngleConfiguration** shall have the content *Annular*.
- **IlluminationAngle** shall have content *45.0* or *0.0*.
- **MeasurementAngle** shall be present and shall have content of *0.0* or *45.0* and shall not have the same content as **IlluminationAngle**.

When a **SphereGeometry** element is used, it shall have the content *Specular_Included*, *Specular_Excluded* or *Diffuse*.

- **MeasurementSpec/Aperture** shall be present and shall be a string indicating the aperture of the device in mm, for example, '4 mm'.

- **MeasurementSpec/Backing** shall be present and shall be one of: White, Black or Unknown.
- **MeasurementSpec/WavelengthRange/@StartWL** shall be no higher than 400.
- **MeasurementSpec/WavelengthRange/@Increment** shall be no higher than 10.
- **MeasurementSpec/Device/Manufacturer** should be present, and when present, its content shall be the name of the manufacturer of the measuring instrument used to collect measurements.
- **MeasurementSpec/Device/Model**: should be present, and when present, its content shall be the model name of the measuring instrument used to collect measurements.
- **MeasurementSpec/Device/@CalibrationStandard** should be present, and when present, its content shall be the calibration standard to which the measuring instrument used to collect measurements was calibrated to, for example, 'NIST'.

4.3.5 CustomResources

4.3.5.1 CustomResources element

The **CustomResources** element shall include a **SpotInkCharacterisation** element for each ink. The example below shows the structure of the **CustomResource** element.

EXAMPLE This example shows the structure of the **CustomResource** element.

```
<CustomResources>
<SpotInkCharacterisation SpotInkName="ExampleRedSpot" SubstrateName="White board"
    SubstrateType="Coated Paper">
  <MeasurementSet Background="Substrate">
    <Measurement TintLevel="0.0" ObjectRef="A1"/>
    ...other tint levels...
    <Measurement TintLevel="50.0" ObjectRef="F1"/>
    ...other tint levels...
    <Measurement TintLevel="100.0" ObjectRef="K1"/>
  </MeasurementSet>
  <MeasurementSet Background="Process_Black">
    <Measurement TintLevel="0.0" ObjectRef="A2"/>
    ...other tint levels...
    <Measurement TintLevel="50.0" ObjectRef="F2"/>
    ...other tint levels...
    <Measurement TintLevel="100.0" ObjectRef="K2"/>
  </MeasurementSet>
</SpotInkCharacterisation>
</CustomResources>
```

4.3.5.2 SpotInkCharacterisation element

The **SpotInkCharacterisation** element provides metadata describing the set of measurements contained in the file. The requirements for each element and attribute used by these **CustomResources** are described in this clause.

SpotInkCharacterisation/@SpotInkName shall be present and shall indicate the name by which this ink is known.

NOTE Naming convention of the spot inks can be generalised, for example, <color_region>&<sequential_number>. Thus, "YL0042" represent Yellow region with 0042 sequential number.

SpotInkCharacterisation/@SubstrateName shall be present and shall indicate the name by which the substrate on which the ink is printed is known.

SpotInkCharacterisation/@SubstrateType shall be present and shall indicate the category of substrate. One of the following values shall be used: Coated Paper, Uncoated Paper, Cardboard, Glossy White Film, Transparent Film, Metallic Film, Transparent Film (reverse), Leather, Metal, Paint, Paper, Plastic, Textile, Tile, Vinyl, Wood, Ceramic, Other.

SpotInkCharacterisation/@SurfaceFinish should be present, and when present, shall be one of the following values: *None*, *Gloss Laminated*, *Matt Laminated*, *Gloss Varnished*, *Matt Varnished*, *Other*.

SpotInkCharacterisation/@InventoryID should be present, and when present, shall indicate the ID by which the ink is identified within a workflow.

SpotInkCharacterisation/@PrintProcess should be present and when present, shall indicate the category of the printing process used to print the set of patches used to characterise the ink. One of the following values shall be used: *ElectroInk*, *Electrophotography*, *Flexography*, *Rotogravure*, *InkJet*, *OffsetLithography*, *ScreenPrinting*, *Other*.

A **SpotInkCharacterisation/MeasurementSet** element shall be included for each tint ramp.

SpotInkCharacterisation/MeasurementSet/@Background shall be present and shall indicate the background for the set of patches, for example: *Substrate*, *Process_Black*, *Other*.

These names should be used to indicate the standard backgrounds but as these are just a means of grouping measurements additional background names can be used if needed.

A **SpotInkCharacterisation/MeasurementSet/Measurement** element shall be included for each patch of the tint ramp.

SpotInkCharacterisation/MeasurementSet/Measurement/@TintLevel shall be present and shall indicate the tint level of the patch to which the measurement applies. These values shall be percentage tint value in the range 0 to 100.

NOTE There is currently no standard way to calculate the tint level, although some work is underway to standardise this aspect, and so, it is useful to communicate the method used.

SpotInkCharacterisation/MeasurementSet/Measurement/@ObjectRef shall be present and shall have the same value as the *Id* of the **Object** element that includes the measurement data.

SpotInkCharacterisation/MeasurementSet/Measurement/@ReflectanceSpectrumName shall be present when more than one **ReferenceSpectrum** elements are included in an **Object** and shall have the same value as the *Name* of the **ReflectanceSpectrum** element that includes the measurement data.

Annex A (normative)

XML schema for CxF/X-4 CustomResource

The schema fragment contained in file ISO 17972-4_CxFX-4_schema.xml (included as an electronic insert) describes the CxF/X-4 CustomResource and can be used as the basis of a validator for CxF/X-4 data files.

Annex B (informative)

Examples of CxF/X-4 documents

Two examples of CxF/X-4 documents are included as electronic inserts.

The first example shows how measurement data for a Red spot colour ink can be encoded as CxF/X-4 and is contained in file ISO 17972-4_CxFX-4_Example 1.xml.

The second example shows how multiple ReflectanceSpectrum elements can be included in a single Object and is contained in file ISO 17972-4_CxFX-4_Example 2.xml.

Annex C (informative)

CxF Core schema

C.1 General

To validate a CxF file or validate a CustomResource that references the CxF3 schema, it is necessary to have access to the CxF3 schema itself. The CxF3 schema is included in this part of ISO 17972 as electronic file CxF3_Core.xsd. A diagram of the CxF3_Schema is included as CxF3_Schema_Diagram.pdf.

C.2 Modification of the CxF3 schema

It is important to note that the CxF3 schema itself shall not be modified except to point to an associated CustomResource. Arbitrary modification or additions to the CxF3 core schema would affect interoperability of the file. Modification is the function of CustomResources.

Bibliography

- [1] ISO 12642-2:2006, *Graphic technology — Input data for characterization of 4-colour process printing — Part 2: Expanded data set*
- [2] ISO 12642-1:2011, *Graphic technology — Input data for characterization of four-colour process printing — Part 1: Initial data set*
- [3] ISO 17972-1¹⁾, *Graphic technology — Colour data exchange format — Part 1: Relationship to CxF3 (CxF/X)*
- [4] ISO 17972-2²⁾, *Graphic technology -- Colour data exchange format (CxF/X) -- Part 2: Scanner target data (CxF/X-2)*
- [5] ISO 17972-3³⁾, *Graphic technology -- Colour data exchange format (CxF/X) -- Part 3: Output target data (CxF/X-3)*
- [6] LANGUAGE E.M. (XML) 1.0 (Second Edition), World Wide Web Consortium (W3C), W3C Recommendation 6 October 2000. Available from Internet <http://www.w3.org>.
- [7] TRANSFORMATIONS X.S.L. (XSLT) Version 1.0, World Wide Web Consortium (W3C), W3C Recommendation 16 November 1999. Available from Internet <http://www.w3.org>.
- [8] Color Exchange Format 3.0 (CxF 3.0) documents. Available from the Internet <http://www.colorexchangeformat.com>

1) This document also assumes familiarity with the concepts and terminology used when describing XML and CxF.

2) Under preparation.

3) Under preparation.

British Standards Institution (BSI)

BSI is the national body responsible for preparing British Standards and other standards-related publications, information and services.

BSI is incorporated by Royal Charter. British Standards and other standardization products are published by BSI Standards Limited.

About us

We bring together business, industry, government, consumers, innovators and others to shape their combined experience and expertise into standards-based solutions.

The knowledge embodied in our standards has been carefully assembled in a dependable format and refined through our open consultation process. Organizations of all sizes and across all sectors choose standards to help them achieve their goals.

Information on standards

We can provide you with the knowledge that your organization needs to succeed. Find out more about British Standards by visiting our website at bsigroup.com/standards or contacting our Customer Services team or Knowledge Centre.

Buying standards

You can buy and download PDF versions of BSI publications, including British and adopted European and international standards, through our website at bsigroup.com/shop, where hard copies can also be purchased.

If you need international and foreign standards from other Standards Development Organizations, hard copies can be ordered from our Customer Services team.

Subscriptions

Our range of subscription services are designed to make using standards easier for you. For further information on our subscription products go to bsigroup.com/subscriptions.

With **British Standards Online (BSOL)** you'll have instant access to over 55,000 British and adopted European and international standards from your desktop. It's available 24/7 and is refreshed daily so you'll always be up to date.

You can keep in touch with standards developments and receive substantial discounts on the purchase price of standards, both in single copy and subscription format, by becoming a **BSI Subscribing Member**.

PLUS is an updating service exclusive to BSI Subscribing Members. You will automatically receive the latest hard copy of your standards when they're revised or replaced.

To find out more about becoming a BSI Subscribing Member and the benefits of membership, please visit bsigroup.com/shop.

With a **Multi-User Network Licence (MUNL)** you are able to host standards publications on your intranet. Licences can cover as few or as many users as you wish. With updates supplied as soon as they're available, you can be sure your documentation is current. For further information, email bsmusales@bsigroup.com.

BSI Group Headquarters

389 Chiswick High Road London W4 4AL UK

Revisions

Our British Standards and other publications are updated by amendment or revision.

We continually improve the quality of our products and services to benefit your business. If you find an inaccuracy or ambiguity within a British Standard or other BSI publication please inform the Knowledge Centre.

Copyright

All the data, software and documentation set out in all British Standards and other BSI publications are the property of and copyrighted by BSI, or some person or entity that owns copyright in the information used (such as the international standardization bodies) and has formally licensed such information to BSI for commercial publication and use. Except as permitted under the Copyright, Designs and Patents Act 1988 no extract may be reproduced, stored in a retrieval system or transmitted in any form or by any means – electronic, photocopying, recording or otherwise – without prior written permission from BSI. Details and advice can be obtained from the Copyright & Licensing Department.

Useful Contacts:

Customer Services

Tel: +44 845 086 9001

Email (orders): orders@bsigroup.com

Email (enquiries): cservices@bsigroup.com

Subscriptions

Tel: +44 845 086 9001

Email: subscriptions@bsigroup.com

Knowledge Centre

Tel: +44 20 8996 7004

Email: knowledgecentre@bsigroup.com

Copyright & Licensing

Tel: +44 20 8996 7070

Email: copyright@bsigroup.com



...making excellence a habit.™