

**Plastics piping systems
— Mechanical fittings for
pressure piping systems —
Specifications**

National foreword

This British Standard is the UK implementation of ISO 17885:2015. It supersedes BS ISO 10838-1:2000 and BS ISO 10838-2:2000 and BS ISO 10838-3:2001 which are withdrawn.

The UK participation in its preparation was entrusted to Technical Committee PRI/88/2, Plastics piping for pressure applications.

A list of organizations represented on this committee can be obtained on request to its secretary.

This publication does not purport to include all the necessary provisions of a contract. Users are responsible for its correct application.

© The British Standards Institution 2015.
Published by BSI Standards Limited 2015

ISBN 978 0 580 77248 1

ICS 23.040.45; 75.200

Compliance with a British Standard cannot confer immunity from legal obligations.

This British Standard was published under the authority of the Standards Policy and Strategy Committee on 30 September 2015.

Amendments issued since publication

Date	Text affected
------	---------------

INTERNATIONAL
STANDARD

BS ISO 17885:2015

ISO
17885

First edition
2015-09-01

Plastics piping systems — Mechanical fittings for pressure piping systems — Specifications

Systèmes de canalisations en plastiques — Raccords mécaniques pour les canalisations sous pression — Spécifications



Reference number
ISO 17885:2015(E)

© ISO 2015



COPYRIGHT PROTECTED DOCUMENT

© ISO 2015, Published in Switzerland

All rights reserved. Unless otherwise specified, no part of this publication may be reproduced or utilized otherwise in any form or by any means, electronic or mechanical, including photocopying, or posting on the internet or an intranet, without prior written permission. Permission can be requested from either ISO at the address below or ISO's member body in the country of the requester.

ISO copyright office
Ch. de Blandonnet 8 • CP 401
CH-1214 Vernier, Geneva, Switzerland
Tel. +41 22 749 01 11
Fax +41 22 749 09 47
copyright@iso.org
www.iso.org

Contents

Page

Foreword	v
Introduction	vi
1 Scope	1
2 Normative references	1
3 Terms, definitions, symbols and abbreviated terms	4
3.1 Terms and definitions.....	4
3.2 Symbols and abbreviated terms.....	6
3.2.1 Materials.....	6
3.2.2 Applications.....	7
4 Manufacturers declaration for the field of application	7
5 Material	8
5.1 Plastic materials.....	8
5.2 Metals.....	9
5.3 Elastomers.....	10
5.4 Lubricants and/or greases.....	11
6 General characteristics	11
6.1 Appearance.....	11
6.2 Colour.....	11
6.3 Ultraviolet protection.....	11
6.4 Threads.....	11
6.5 Transition fittings to metal pipes.....	11
6.6 Combined fittings.....	11
6.7 Twisting.....	11
7 Geometrical characteristics	11
8 Physical characteristics	12
8.1 Evaluation of the MRS value of the plastic material.....	12
8.2 Verification of long-term behaviour of the plastic material.....	12
8.3 Specific material related characteristics of fitting materials.....	12
8.4 Application-related characteristics.....	13
8.4.1 Effect on water quality (W).....	13
8.4.2 Resistance to gas constituents (GAS).....	13
8.4.3 Chemical resistance of fittings for industrial applications (IS).....	14
9 Performance requirements	14
9.1 General.....	14
9.2 Pressure resistance of the fitting body.....	15
9.2.1 Preparation of test piece.....	15
9.2.2 Testing of pressure resistance.....	15
9.3 Fitting assemblies.....	15
9.3.1 Preparation of test assemblies.....	15
9.3.2 Test scheme.....	15
9.3.3 Requirements.....	17
10 Marking	27
11 Packaging	27
Annex A (informative) List of standards	28
Annex B (normative) Stiffener requirements	29
Annex C (normative) Test pressure of materials and fitting bodies	30
Annex D (normative) Physical characteristics of fitting materials	32

Annex E (normative) Resistance to gas constituents	37
Annex F (normative) Test stresses	38
Annex G (normative) Cyclic test procedure	40
Bibliography	41

Foreword

ISO (the International Organization for Standardization) is a worldwide federation of national standards bodies (ISO member bodies). The work of preparing International Standards is normally carried out through ISO technical committees. Each member body interested in a subject for which a technical committee has been established has the right to be represented on that committee. International organizations, governmental and non-governmental, in liaison with ISO, also take part in the work. ISO collaborates closely with the International Electrotechnical Commission (IEC) on all matters of electrotechnical standardization.

The procedures used to develop this document and those intended for its further maintenance are described in the ISO/IEC Directives, Part 1. In particular the different approval criteria needed for the different types of ISO documents should be noted. This document was drafted in accordance with the editorial rules of the ISO/IEC Directives, Part 2 (see www.iso.org/directives).

Attention is drawn to the possibility that some of the elements of this document may be the subject of patent rights. ISO shall not be held responsible for identifying any or all such patent rights. Details of any patent rights identified during the development of the document will be in the Introduction and/or on the ISO list of patent declarations received (see www.iso.org/patents).

Any trade name used in this document is information given for the convenience of users and does not constitute an endorsement.

For an explanation on the meaning of ISO specific terms and expressions related to conformity assessment, as well as information about ISO's adherence to the WTO principles in the Technical Barriers to Trade (TBT) see the following URL: [Foreword - Supplementary information](#)

The committee responsible for this document is ISO/TC 138, *Plastics pipes, fittings and valves for the transport of fluids*, Subcommittee SC 4, *Plastics pipes and fittings for the supply of gaseous fuels* in close collaboration with Subcommittee SC 2, *Plastics pipes and fittings for water supplies* and Subcommittee SC 3, *Plastics pipes and fittings for industrial applications*.

This first edition cancels and replaces ISO 10838-1:2000, ISO 10838-2:2000, ISO 10838-3:2001, and ISO 14236:2000, which have been technically revised.

Introduction

This International Standard specifies the requirements for mechanical fittings for joining plastic piping systems for the supply of gaseous fuels, the supply of water for human consumption and other purposes, as well as for industrial application.

It provides a unified set of test methods to check the performance of the fittings, depending on their intended use.

It is the responsibility of the purchaser or specifier to select the appropriate fitting, taking into account their particular requirements and any relevant national guidance or regulations and installation practices or codes.

Products must comply, when existing, with national regulations and testing arrangements that ensure fitness for purpose.

Plastics piping systems — Mechanical fittings for pressure piping systems — Specifications

1 Scope

This International Standard specifies the requirements and test methods for mechanical fittings intended to join plastic pressure piping systems including transition fittings to metal pipes for the following:

- supply of gaseous fuels (GAS);
- supply of water for human consumption (W), including raw water prior to treatment and for the supply of water for general purpose, as well as underground drainage and sewerage under pressure (P);
- supply of water for irrigation (I);
- industrial applications (IS).

This International Standard is applicable only to mechanical fittings with operating-temperature and pressure limits as indicated in the relevant systems standards.

NOTE A list of International Standard for plastic pipes for which mechanical fittings can be used can be found in [Annex A](#).

Flanges are not covered by this International Standard.

Mechanical fittings for hot and cold water systems inside buildings, as well as for district heating applications, are not covered by this International Standard.

2 Normative references

The following documents, in whole or in part, are normatively referenced in this document and are indispensable for its application. For dated references, only the edition cited applies. For undated references, the latest edition of the referenced document (including any amendments) applies.

ISO 7-1, *Pipe threads where pressure-tight joints are made on the threads — Part 1: Dimensions, tolerances and designation*

ISO 75-2, *Plastics — Determination of temperature of deflection under load — Part 2: Plastics and ebonite*

ISO 228-1, *Pipe threads where pressure-tight joints are not made on the threads — Part 1: Dimensions, tolerances and designation*

ISO 306, *Plastics — Thermoplastic materials — Determination of Vicat softening temperature (VST)*

ISO 307, *Plastics — Polyamides — Determination of viscosity number*

ISO 472, *Plastics — Vocabulary*

ISO 580:2005, *Plastics piping and ducting systems — Injection-moulded thermoplastics fittings — Methods for visually assessing the effects of heating*

ISO 1043-1, *Plastics — Symbols and abbreviated terms — Part 1: Basic polymers and their special characteristics*

ISO 1133-1, *Plastics — Determination of the melt mass-flow rate (MFR) and melt volume-flow rate (MVR) of thermoplastics — Part 1: Standard method*

ISO 1167-1, *Thermoplastics pipes, fittings and assemblies for the conveyance of fluids — Determination of the resistance to internal pressure — Part 1: General method*

ISO 1167-2, *Thermoplastics pipes, fittings and assemblies for the conveyance of fluids — Determination of the resistance to internal pressure — Part 2: Preparation of pipe test pieces*

ISO 1167-3, *Thermoplastics pipes, fittings and assemblies for the conveyance of fluids — Determination of the resistance to internal pressure — Part 3: Preparation of components*

ISO 1167-4, *Thermoplastics pipes, fittings and assemblies for the conveyance of fluids — Determination of the resistance to internal pressure — Part 4: Preparation of assemblies*

ISO 2507-1, *Thermoplastics pipes and fittings — Vicat softening temperature — Part 1: General test method*

ISO 2507-2, *Thermoplastics pipes and fittings — Vicat softening temperature — Part 2: Test conditions for unplasticized poly(vinyl chloride) (PVC-U) or chlorinated poly(vinyl chloride) (PVC-C) pipes and fittings and for high impact resistance poly(vinyl chloride) (PVC-HI) pipes*

ISO 3451-4:1998, *Plastics — Determination of ash — Part 4: Polyamides*

ISO 3458, *Plastics piping systems — Mechanical joints between fittings and pressure pipes — Test method for leak tightness under internal pressure*

ISO 3459, *Plastic piping systems — Mechanical joints between fittings and pressure pipes — Test method for leak tightness under negative pressure*

ISO 3501, *Plastics piping systems — Mechanical joints between fittings and pressure pipes — Test method for resistance to pull-out under constant longitudinal force*

ISO 3503, *Plastics piping systems — Mechanical joints between fittings and pressure pipes — Test method for leak tightness under internal pressure of assemblies subjected to bending*

ISO 4437-1:2014, *Plastics piping systems for the supply of gaseous fuels — Polyethylene (PE) — Part 1: General*

ISO 4633, *Rubber seals — Joint rings for water supply, drainage and sewerage pipelines — Specification for materials*

ISO 6509, *Corrosion of metals and alloys — Determination of dezincification resistance of brass*

ISO 6957, *Copper alloys — Ammonia test for stress corrosion resistance*

ISO 6993-1, *Buried, high-impact poly(vinyl chloride) (PVC-HI) piping systems for the supply of gaseous fuels — Part 1: Pipes for a maximum operating pressure of 1 bar (100 kPa)*

ISO 6993-2, *Buried, high-impact poly(vinyl chloride) (PVC-HI) piping systems for the supply of gaseous fuels — Part 2: Fittings for a maximum operating pressure of 200 mbar (20 kPa)*

ISO 6993-3, *Buried, high-impact poly(vinyl chloride) (PVC-HI) piping systems for the supply of gaseous fuels — Part 3: Fittings and saddles for a maximum operating pressure of 1 bar (100 kPa)*

ISO 7686, *Plastics pipes and fittings — Determination of opacity*

ISO 9080, *Plastics piping and ducting systems — Determination of the long-term hydrostatic strength of thermoplastics materials in pipe form by extrapolation*

ISO 10147, *Pipes and fittings made of crosslinked polyethylene (PE-X) — Estimation of the degree of crosslinking by determination of the gel content*

ISO 12162, *Thermoplastics materials for pipes and fittings for pressure applications — Classification, designation and design coefficient*

- ISO 13783, *Plastics piping systems — Unplasticized poly(vinyl chloride) (PVC-U) end-load-bearing double-socket joints — Test method for leaktightness and strength while subjected to bending and internal pressure*
- ISO 13844, *Plastics piping systems — Elastomeric-sealing-ring-type socket joints for use with plastic pressure pipes — Test method for leaktightness under negative pressure, angular deflection and deformation*
- ISO 13845, *Plastics piping systems — Elastomeric-sealing-ring-type socket joints for use with thermoplastic pressure pipes — Test method for leaktightness under internal pressure and with angular deflection*
- ISO 13951, *Plastics piping systems — Test method for the resistance of plastic pipe/pipe or pipe/fitting assemblies to tensile loading*
- ISO 16010, *Elastomeric seals — Material requirements for seals used in pipes and fittings carrying gaseous fuels and hydrocarbon fluids*
- ISO 16486-1:2012, *Plastics piping systems for the supply of gaseous fuels - Unplasticized polyamide (PA-U) piping systems with fusion jointing and mechanical jointing — Part 1: General*
- ISO 17456:2006, *Plastics piping systems — Multilayer pipes — Determination of long-term strength*
- ISO 17467-1:2012, *Plastics piping systems for the supply of gaseous fuels — Unplasticized polyamide (PA-U) piping systems jointed by solvent cement — Part 1: General*
- ISO 17778, *Plastics piping systems — Fittings, valves and ancillaries — Determination of gaseous flow rate/pressure drop relationships*
- ISO 19899, *Plastics piping systems — Polyolefin pipes and mechanical fitting assemblies — Test method for the resistance to end load (AREL test)*
- ISO 23711, *Elastomeric seals — Requirements for materials for pipe joint seals used in water and drainage applications — Thermoplastic elastomers*
- EN 681-1, *Elastomeric seals — Materials requirements for pipe joint seals used in water and drainage applications — Part 1: Vulcanized rubber*
- EN 681-2, *Elastomeric seals — Materials requirements for pipe joint seals used in water and drainage applications — Part 2: Thermoplastic elastomers*
- EN 682, *Elastomeric seals — Materials requirements for seals used in pipes and fittings carrying gas and hydrocarbon fluids*
- EN 1982, *Copper and copper alloys — Ingots and castings*
- EN 10208-1, *Steel pipes for pipelines for combustible fluids — Technical delivery conditions — Part 1: Pipes of requirement class A*
- EN 10213, *Steel castings for pressure purposes*
- EN 10216-1, *Seamless steel tubes for pressure purposes — Technical delivery conditions — Part 1: Non-alloy steel tubes with specified room temperature properties*
- EN 10216-3, *Seamless steel tubes for pressure purposes — Technical delivery conditions — Part 3: Alloy fine grain steel tubes*
- EN 10216-5, *Seamless steel tubes for pressure purposes — Technical delivery conditions — Part 5: Stainless steel tubes*
- EN 10217-1, *Welded steel tubes for pressure purposes — Technical delivery conditions — Part 1: Non-alloy steel tubes with specified room temperature properties*
- EN 10217-3, *Welded steel tubes for pressure purposes — Technical delivery conditions — Part 3: Alloy fine grain steel tubes*

EN 10224, *Non-alloy steel tubes and fittings for the conveyance of aqueous liquids including water for human consumption — Technical delivery conditions*

EN 10296-2, *Welded circular steel tubes for mechanical and general engineering purposes — Technical delivery conditions — Part 2: Stainless steel*

EN 12164, *Copper and copper alloys — Rod for free machining purposes*

EN 12165, *Copper and copper alloys — Wrought and unwrought forging stock*

EN 12449, *Copper and copper alloys — Seamless, round tubes for general purposes*

CEN/TS 13388, *Copper and copper alloys — Compendium of compositions and products*

3 Terms, definitions, symbols and abbreviated terms

3.1 Terms and definitions

For the purposes of this document, the terms and definitions given in ISO 472, ISO 1043-1, and the following apply.

3.1.1

mechanical fitting

fitting for assembling plastics pipes with each other or with a metal pipe or fitting, which includes one or more compression zones to provide pressure integrity, leak tightness and resistance to end loads

3.1.2

full-end-load resistance

combination of component and joint design and characteristics such that under any load condition the plastic pipe will fail first

3.1.3

end-load resistance

resistance to end load transmitted via the connecting pipe and generated by internal pressure, pipeline external interference, and thermally induced pipe stresses in any combination

3.1.4

non-end-load resistance

lack of resistance to axial loads without additional external mechanical axial support

3.1.5

lower confidence limit of predicted hydrostatic strength

σ_{LPL}

quantity, with the dimensions of stress, which represents the 97,5 % lower confidence limit of the predicted hydrostatic strength at a temperature θ and time t

Note 1 to entry: It is expressed in megapascals.

Note 2 to entry: Temperature, θ , is expressed in degrees Celsius and time, t , is expressed in years.

[SOURCE: ISO 12162:2009, 3.2]

3.1.6

minimum required strength

MRS

value of σ_{LPL} at 20 °C and 50 years, rounded down to the next smaller value of the R10 series when σ_{LPL} is below 10 MPa, or to the next lower value of the R20 series when σ_{LPL} is 10 MPa or greater

Note 1 to entry: The R10 series conforms to ISO 3[1] and the R20 series conforms to ISO 497[2].

[SOURCE: ISO 4437-1:2014, 3.3.2]

3.1.7
design coefficient
C

coefficient with a value greater than 1, which takes into consideration service conditions, as well as properties of the components of a piping system other than those represented in the lower confidence limit

[SOURCE: ISO 12162:2009, 3.5]

3.1.8
design stress

σ_s
allowable stress for a given application at 20 °C, that is derived from the MRS by dividing it by the coefficient *C*, i.e.:

$$\sigma_s = \frac{\text{MRS}}{C}$$

Note 1 to entry: It is expressed in megapascals.

[SOURCE: ISO 4437-1:2014, 3.3.3]

3.1.9
gaseous fuel

any fuel which is in the gaseous state at a temperature of 15 °C and a pressure of 1 bar

Note 1 to entry: 1 bar = 0,1 MPa = 10⁵ Pa; 1 MPa = 1 N/mm².

[SOURCE: ISO 4437-1:2014, 3.4.1]

3.1.10
standard dimension ratio
SDR

numerical designation of a pipe series, which is a convenient round number, approximately equal to the dimension ratio of the nominal outside diameter, *d_n*, and the nominal wall thickness, *e_n*

[SOURCE: ISO 4437-1:2014, 3.1.15]

3.1.11
maximum operating pressure
MOP

maximum effective pressure of gas in a piping system, expressed in bar, which is allowed in continuous use

Note 1 to entry: It takes into account the physical and the mechanical characteristics of the components of the piping system (and the influence of the gas on these characteristics) and it is calculated using the following formula:

$$\text{MOP} = \frac{20 \times \text{MRS}}{C \times (\text{SDR} - 1)}$$

3.1.12
nominal pressure
PN

numerical designation, which is a convenient rounded number for reference purposes

Note 1 to entry: For plastic piping systems conveying water, it corresponds to the maximum continuous operating pressure, expressed in bar, which can be sustained with water at 20 °C, based on the minimum design coefficient.

3.1.13

virgin material

material in a form such as granules or powder that has not been subjected to use or processing other than that required for its manufacture and to which no reprocessable or recyclable materials have been added

3.1.14

own reprocessable material

material, of the same grade, prepared from clean rejected unused components, that will be reprocessed in a manufacturer's plant after having been previously processed by the same manufacturer in the production of same components by, for example, injection moulding

3.1.15

recycled material

material comprising one of the following:

- a) material from used pipes or fittings which have been cleaned and crushed or ground
- b) material from used thermoplastic products other than pipes or fittings which have been cleaned and crushed or ground

3.2 Symbols and abbreviated terms

3.2.1 Materials

3.2.1.1 Plastics

ABS	acrylonitrile-butadiene-styrene
ECTFE	ethylene chlorotrifluorethylene
PA	polyamide
PB	polybutene
PE	polyethylene
PE-RT	polyethylene of raised temperature resistance
PE-X	crosslinked polyethylene
POM	polyoxymethylene, polyformaldehyde
PP-B	polypropylene block-copolymer
PP-H	polypropylene homopolymer
PP-R	polypropylene random-copolymer
PP-RCT	polypropylene random-copolymer with modified crystallinity
PPSU	poly(phenylene sulfone)
PSU	polysulfone
PVC-C	chlorinated poly(vinyl chloride)
PVC-HI	high-impact poly(vinyl chloride)
PVC-O	oriented unplasticized poly(vinyl chloride)

PVC-U	unplasticized poly(vinyl chloride)
PVDF	poly(vinylidene fluoride)

3.2.1.2 Metals

Al	aluminium
Cu	copper
Cu-DHP	phosphorus deoxidized copper
Cu-OF	oxygen-free copper
Fe	iron
Pb	lead
Sn	tin
Zn	zinc

3.2.1.3 Other

As	arsenic
C	carbon
GF	glass fibre

3.2.2 Applications

GAS	supply of gaseous fuels
W	supply of water for human consumption, including raw water prior to treatment and for the supply of water for general purpose
P	supply of underground drainage and sewerage under pressure
I	supply of water for irrigation
IS	industrial applications

NOTE Symbols taken from CEN/TR 15438.[3]

4 Manufacturers declaration for the field of application

The manufacturer shall declare, depending on the intended use, the medium supplied, the nominal pressure (PN), the pipe material(s) to be jointed, the use of a stiffener, the end load resistance class, the corrosion resistance, ash content for glass reinforced materials, installation and operating temperature limits, as applicable, of the mechanical fittings. This declaration shall be included in the products technical file.

NOTE MOP for GAS is dependent on the design coefficient (*C*) and applied by the network engineer.

5 Material

5.1 Plastic materials

The compound/formulation used to manufacture any plastic components of the fitting exposed to ultraviolet radiation shall be ultraviolet resistant.

Pressure-bearing components shall be produced from virgin materials, own reprocessable material or a combination of virgin and own reprocessable material. Recycled materials shall not be used. For glass reinforced materials, only virgin materials shall be used.

[Table 1](#) lists components and fitting body materials in contact with the medium commonly used in practice for GAS, W, P and I. The suitability of the materials with “no experience” or other materials, which are not mentioned in [Table 1](#), shall be demonstrated in agreement between manufacturer and end-user.

The component and fitting body materials for IS depends on the medium supplied (see [8.4.3](#)).

Table 1 — Plastic components and fitting body materials

Material	Minimum value of MRS MPa	Suitable for ^a	
		GAS	W, P, I
ABS	12,5	N.E.	Y
ECTFE	18,4	N.E.	Y
PA 11 160	16,0	Y	N
PA 11 180	18,0	Y	N
PA 12 160	16,0	Y	N
PA 12 180	18,0	Y	N
PA 12-GF30	20,0	Y	Y
PA 12-GF50	20,0	Y	Y
PA 12-GF65	20,0	Y	Y
PB	12,5	N.E.	Y
PE 80	8,0	Y	Y
PE 100	10,0	Y	Y
PE-RT Type 1	8,0	N.E.	Y
PE-RT Type 2	8,0	N.E.	Y
PE-X	8,0	Y	Y
POM ^b	10,0	Y	Y
PP-B	8,0	N.E.	Y
PP-H	10,0	N.E.	Y
PP-R	8,0	N.E.	Y
PP-RCT	11,2	N.E.	Y
PPSU	32,0	N.E.	Y
PSU	16,0	N.E.	Y
PVC-C	20,0	N	Y
PVC-HI	14,0	Y	Y
PVC-O 315	31,5	N.E.	Y

^a Y = Yes, N = No, N.E. = No experience with this material.
^b Copolymer and homopolymer.

Table 1 (continued)

Material	Minimum value of MRS MPa	Suitable for ^a	
		GAS	W, P, I
PVC-O 355	35,5	N.E.	Y
PVC-O 400	40,0	N.E.	Y
PVC-O 450	45,0	N.E.	Y
PVC-O 500	50,0	N.E.	Y
PVC-U	25,0	N	Y
PVDF	25,0	N.E.	Y

^a Y = Yes, N = No, N.E. = No experience with this material.
^b Copolymer and homopolymer.

5.2 Metals

The fitting body and components for transition fittings should be made from one or more of the materials listed in [Table 2](#).

The materials should be corrosion resistant or should be protected against corrosion, according to their intended end-use conditions unless otherwise stated in manufacturer's declaration (see [Clause 4](#)).

Table 2 — Example of commonly used metal fitting materials

Material designation symbol	Relevant standard	
Copper	Cu-DHP	EN 12449
	Cu-OF	CEN/TS 13388
Copper alloys	CuSn ₅ Zn ₅ Pb ₅ -C	EN 1982
	CuSn ₃ Zn ₈ Pb ₅ -C	EN 1982
	CuSn ₇ Zn ₂ Pb ₃ -C	EN 1982
	CuSn ₇ Zn ₄ Pb ₇ -C	EN 1982
	CuSn ₅ Zn ₅ Pb ₃ -C	EN 1982
	CuZn ₃₉ Pb ₃	EN 12164, EN 12165
	CuZn ₄₀ Pb ₂	EN 12164, EN 12165
	CuZn ₃₆ Pb ₂ As	EN 12164, EN 12165
	CuZn ₃₅ Pb ₂ Al-C	EN 1982
	CuZn ₃₉ Pb ₁ Al-C	EN 1982
	CuZn ₃₃ Pb ₂ -C	EN 1982
	CuZn ₁₅ As-C	EN 1982
Spheroidal graphite cast iron		ISO 1083
Malleable cast iron		ISO 5922:2005 ^a
Unalloyed steel	L235 (1.0252)	EN 10224
	L235GA (1.0458)	EN 10208-1
	L355 (1.0419)	EN 10224
	L360GA (1.0499)	EN 10208-1
	P235TR1 (1.0254)	EN 10216-1, EN 10217-1
	P235TR2 (1.0255)	EN 10216-1, EN 10217-1

^a Excluded material grade ISO 5922/JMB/275-5.

Table 2 (continued)

Material designation symbol		Relevant standard
	P355N (1.0562)	EN 10216-3, EN 10217-3
Stainless steel	1.4301	EN 10216-5
	1.4401	EN 10216-5
	1.4404	EN 10216-5
	1.4408	EN 10213
	1.4521	EN 10296-2
	1.4571	EN 10216-5
	1.4581	EN 10213
	1.5710	EN 10216-5
	^a Excluded material grade ISO 5922/JMB/275-5.	

5.3 Elastomers

The material of elastomeric sealing elements in fittings shall conform to the standards given in [Table 3](#) and [Table 4](#) depending on the application.

For industrial (IS) and irrigation (I) applications, the material used for elastomeric sealing elements should be chosen as appropriate.

Table 3 — W and P applications

Type	Application	Standards
WA	Cold potable water	ISO 4633 ^a
WC	Cold non-potable water supply, drainage, sewerage and rainwater	ISO 4633 ^a
WG	Cold non-potable water supply, drainage, sewerage and rainwater pipes with oil resistance	ISO 4633 ^a
WT	Waste water and drainage application – Thermoplastic elastomers	ISO 23711 ^b
WH	Waste water and drainage application with oil resistance – Thermoplastic elastomers	ISO 23711 ^b

NOTE Attention is drawn to the need to comply with national regulations concerning the effects of materials in contact with water for the purpose of drinking water supply.

^a If an International Standard with the same content exists, e.g. EN 681-1, conformance may alternatively be considered as acceptable.

^b If an International Standard with the same content exists, e.g. EN 681-2, conformance may alternatively be considered as acceptable.

Table 4 — GAS applications

Type	Application	Operating temperature °C	Standards
GA	Gaseous fuel	-5 to 50	ISO 16010 ^a
GAL	Gaseous fuel	-15 to 50	ISO 16010 ^a
GB	Hydrocarbon fluids and gaseous fuels	-5 to 50	ISO 16010 ^a
GBL	Hydrocarbon fluids and gaseous fuels	-15 to 50	ISO 16010 ^a
H	Aromatic hydrocarbon fluids and gaseous fuels – containing condensates	-5 to 50	ISO 16010 ^a

^a If an International Standard with the same content exists, e.g. EN 682, conformance may alternatively be considered as acceptable.

5.4 Lubricants and/or greases

Lubricants and/or greases may be used to assist in joint assembly. The fitting manufacturer shall provide evidence that the lubricant and/or grease shall not have a deleterious effect on the performance of the component parts of the fitting likely to be in contact or of the connecting piping system.

NOTE Requirements for GAS can be found in EN 377.^[4]

6 General characteristics

6.1 Appearance

When viewed without magnification, the internal and external surfaces of fittings shall be smooth, clean and shall have no scoring, cavities and other surface defects to an extent that would prevent conformity to this International Standard.

No component of the fitting shall show any signs of damage, scratches, pitting, bubbles, blisters, inclusions or cracks to an extent that would prevent conformity of the fittings to the requirements of this International Standard.

6.2 Colour

The colour shall conform to the requirements given in the relevant product standards.

For W applications, plastic body material other than black shall be tested in accordance with ISO 7686, the percentage of light which passes through the wall of the fitting shall be less than or equal to 0,2 %.

6.3 Ultraviolet protection

The fitting parts, which are exposed to ultraviolet radiation and affected by ultraviolet radiation, shall be protected against ultraviolet radiation.

6.4 Threads

Joints made pressure-tight by the mating of the threads shall conform to ISO 7-1 and fastening pipe threads to ISO 228-1.

6.5 Transition fittings to metal pipes

Where a fitting is connected to a metal pipe, the joint shall fulfil at least the performance requirements of the plastic pipe systems. The fitting part connected to the metal pipe shall fulfil the dimensional requirements of the corresponding metal product standards.

6.6 Combined fittings

Socket fusion ends, spigot ends, electrofusion sockets or others, when included in mechanical fittings, shall conform to the relevant product standards.

6.7 Twisting

The fitting shall not induce twisting of pipes during assembly.

7 Geometrical characteristics

The mechanical fittings shall be manufactured with such dimensions and within such tolerances as will permit their use with pipes conforming to the corresponding product standard.

Stiffeners are recommended for thin wall pipes (e.g. polyethylene pipes) for GAS applications. If stiffeners are used, they shall comply with [Annex B](#).

In order to avoid excessive pressure losses in straight-line fittings, any internal support used in internal/external grip fittings should cause minimal narrowing of the internal cross-section of the fitting. The minimal internal bore diameter shall be stated by the manufacturer in his technical file.

8 Physical characteristics

8.1 Evaluation of the MRS value of the plastic material

For plastic materials intended to be pressure-bearing and subject to continuous stress, either in hoop or tension, determine the σ_{LPL} value in accordance with ISO 9080. Data provided by the compound manufacturer may be taken into account. Classify the material (MRS) and calculate the design stress in accordance with ISO 12162.

NOTE Plastic materials used to manufacture screw caps, clamping rings and supporting rings do not need to be classified.

8.2 Verification of long-term behaviour of the plastic material

The long-term behaviour of the plastic material of the fitting body shall be verified by a type test either on an injection-moulded pipe or an extruded pipe specimen with an outside diameter, in accordance with the material application, not less than 32 mm produced in accordance with ISO 1167-2 from the same material as that of the fitting body. In case of dispute an injection-moulded pipe specimen shall be used. The test pressure for the plastic sample is given in Formula (1):

$$p_t = PN \times \frac{\sigma_{tF}}{\sigma_s} \quad (1)$$

where

p_t is the test pressure of the sample (bar);

PN is the nominal pressure of the fitting (bar);

σ_{tF} is the test stress of the fitting material (MPa);

σ_s is the design stress of the fitting material (MPa).

The test parameters given in [Annex C](#) shall be followed, using test procedure given in ISO 1167-1. No failure shall occur during the test.

8.3 Specific material related characteristics of fitting materials

[Table 5](#) shows the minimum characteristics of the fitting materials to be tested. The details of the requirements for parts are given in [Annex D](#).

Table 5 — Specific physical characteristics of fittings

Fitting material	Characteristic(s)	Test method
ABS	Vicat softening temperature	ISO 306
ECTFE	MFR	ISO 1133-1
	Heat deflection temperature	ISO 75-2
PA ^a	Viscosity number	ISO 307
PA12-GF50	Viscosity number ^b	ISO 307
PA12-GF30 PA12-GF65	Ash content	ISO 3451-4
PB	MFR	ISO 1133-1
PE ^c	MFR	ISO 1133-1
PE-X	Degree of cross linking	ISO 10147
POM	MFR	ISO 1133-1
PP ^d	MFR	ISO 1133-1
PPSU	MFR	ISO 1133-1
PSU	MFR	ISO 1133-1
PVC ^e	Vicat softening temperature	ISO 2507-1
	Effects of heating	ISO 580:2005
PVDF	MFR	ISO 1133-1
	Vicat softening temperature	ISO 306
Cu alloys	Dezincification resistance	Manufacturer has to confirm corrosion resistance, according to ISO 6509, for specific application where the dezincification resistance is required
Fe alloys	Corrosion resistance	Manufacturer has to declare corrosion resistance for specific application or has to define how the end-user has to provide a proper corrosion protection.
<p>^a PA = PA 11 160, PA 11 180, PA 12 160 or PA 12 180.</p> <p>^b On the base material, performed by the raw material producer.</p> <p>^c PE = PE 80, PE 100, PE-RT type 1 or PE-RT type 2.</p> <p>^d PP = PP-B, PP-H, PP-R or PP-RCT.</p> <p>^e PVC = PVC-C, PVC-HI, PVC-O or PVC-U. Test for PVC-O are to be carried out on feedstock fitting material or on reverted fitting.</p>		

8.4 Application-related characteristics

8.4.1 Effect on water quality (W)

Products complying with this International Standard may be used for the supply of water intended for human consumption if they comply with the relevant national, regional or local regulatory provisions applicable in the place of use.

8.4.2 Resistance to gas constituents (GAS)

Fitting materials, intended to be used in contact with gaseous fuels, shall have a demonstrated resistance to gas constituents.

For fittings made of PE, PE-RT, PE-X, PA, glass-reinforced PA or PVC-HI, the test parameters of [Table 6](#) shall be applied. The compound in the form of pipe used for the manufacture of the fittings shall conform to the requirements given in [Table 6](#).

For other materials, the test parameters and requirements should be agreed upon between manufacturer and the customer, as applicable. The test method described in [Annex E](#) can be used as guideline.

Table 6 — Characteristic of the compound, tested in the form of pipe

Fitting material	Property	Test method	Test parameters	Requirements
PA ^a PA12-GF30 PA12-GF50 PA12-GF65	Stress corrosion resistance	ISO 17467-1:2012, Annex B OR ISO 16486-1:2012, Annex B	Shall conform to ISO 17467-1:2012, Annex B OR Shall conform to ISO 16486-1:2012, Annex B	Change in mean hoop stress at burst between specimens tested in reagent and in the corresponding control fluid ≤20 % OR Change in tensile yield strength of injection moulded bar specimens tested in reagent and in the corresponding control fluid ≤ 20 %
PE ^b	Resistance to gas constituents	Annex E	80 °C 2,0 MPa	≥20 h
PE-RT ^c	Resistance to gas constituents	Annex E	80 °C 2,0 MPa	≥20 h
PE-X	Resistance to gas constituents	Annex E	80 °C 2,0 MPa	≥1 000 h
PVC-HI	Stress corrosion resistance	ISO 6993-1	Shall conform to ISO 6993-1	No crazes of a depth >30 µm
<p>^a PA = PA 11 160, PA 11 180, PA 12 160 or PA 12 180. ^b PE = PE 80 or PE 100. ^c PE-RT = PE-RT type 1 or PE-RT type 2.</p>				

8.4.3 Chemical resistance of fittings for industrial applications (IS)

For industrial applications, the parts shall withstand the chemical demands to be expected and shall be resistant to the fluids to be conveyed.

Where fluids for industrial application are to be conveyed, the effect of the fluid on the component material(s) can be established by consulting the component manufacturer.

NOTE Guidance can be found in ISO/TR 10358 (for plastics)^[5] and ISO/TR 7620 (for rubbers).^[6]

9 Performance requirements

9.1 General

The characteristics to be tested and the related test requirements depend on the field(s) of application, as declared by the manufacturer (see [Clause 4](#)).

9.2 Pressure resistance of the fitting body

9.2.1 Preparation of test piece

For testing fitting bodies, special sealing plugs according to ISO 1167-3, as well as special (reinforced) end-closures, may be used.

9.2.2 Testing of pressure resistance

For plastic materials where an ISO 9080 evaluation has been carried out or where requirements to the long-term pressure resistance exists in a product standard, the test pressure for the fitting body is given in Formula (2):

$$p_t = PN \times \frac{\sigma_{tF}}{\sigma_s} \quad (2)$$

where

p_t is the test pressure of the fitting body (bar);

PN is the nominal pressure of the fitting (bar);

σ_{tF} is the test stress of the fitting material (MPa);

σ_s is the design stress of the fitting material (MPa).

The test parameters given in [Annex C](#) shall be followed, using test procedure given in ISO 1167-1.

No failure shall occur during the test.

NOTE The design stress depends on the application, e.g. to 20 °C/50 years.

9.3 Fitting assemblies

9.3.1 Preparation of test assemblies

The tests shall be carried out on pipe and fitting assembled in accordance with the manufacturer's instructions. The tests shall include all types of joint design.

The pipe(s) used in the test assemblies shall conform to the corresponding product standard if available.

9.3.2 Test scheme

The fittings and pipes shall not be tested until 24 h after their production. For practical reasons, the manufacturer may wait a shorter time before testing. In case of dispute, a duration of 24 h shall apply.

For initial testing (type testing), all relevant characteristics shown in [Table 7](#) should be carried out on a representative selection of diameters, pressure classes (PN) and types.

For factory production, control testing should be defined in the manufacturer's quality plan.

NOTE Since there are PE (polyethylene) materials such as PE 63, which are available only in some markets, the testing under general requirements are also applicable and if the products stand in accordance with the requirements, they can be approved for the particular use.

Table 7 — Test scheme for mechanical fitting assemblies

Characteristics	Requirement	Application		Joint type	Test method
	Subclause	GAS	W, P, I, IS		
Leak tightness under internal pressure	9.3.3.1	X ^a	X ^b	All types	ISO 3458
Long-term pressure test for leak tightness under internal pressure	9.3.3.2	X ^a	X	All types	ISO 3458 ISO 1167-1 ISO 1167-4
Resistance of plastic pipe/pipe or pipe/fitting assemblies to tensile loading at 23 °C	9.3.3.3	X ^a	—	Full-end-load resistant joints ^c	ISO 13951
Resistance to pull out at 23 °C	9.3.3.4	—	X	End-load resistant joints ^d	ISO 3501
Resistance to end load at 80 °C	9.3.3.5	X ^a	—	Full-end-load resistant joints ^{d,e}	ISO 19899
Leak tightness after temperature cycling (outside temperature)	9.3.3.6	X	—	All types	Table 10 ISO 3458
Leak tightness under internal pressure when subjected to bending	9.3.3.7	X ^a	X	All types ^{c,d}	ISO 3503
Leak tightness under negative pressure	9.3.3.8	—	X	All types ^f	ISO 3459
Leak tightness with angular deflection and deformation	9.3.3.9	X ^a	X	Non-end-load resistant joints ^{d,g,h}	ISO 13845 and ISO 13844
Leak tightness and strength while subjected to bending and internal pressure	9.3.3.10	—	X	End-load resistant joints ^{d,i}	ISO 13783
Flow rate pressure drop relationship	9.3.3.11	X	—	All types ^j	ISO 17778
Resistance to stress corrosion	9.3.3.12	X	X	All types ^k	ISO 6957

X = applicable.

— = not tested or not applicable.

NOTE Full-end-load resistance is the condition in which the joint is stronger than the connecting pipe when exposed to all applied end loads (see [3.1](#)).

^a If the mechanical fittings are intended to be assembled by the end user, half of the test pieces shall be assembled at the minimum installation temperature as declared by the manufacturer (see [Clause 4](#)), the other half at the maximum installation temperature.

^b If the leak tightness test under internal pressure when subjected to bending ([9.3.3.7](#)) is carried out and the requirements have been fulfilled, this test is not necessary.

^c Only valid for pipes: PE, PE-X, PB, PP-B and PP-R ≤ 63 mm; multilayer ≤ 32 mm.

^d Test of joint design. Normally performed on uniaxial fitting (coupling) assemblies.

^e Only valid for PE pipes ≤ 63 mm.

^f Only valid for pipes ≤ 63 mm.

^g Only valid for pipes: PVC, PP-H, PVDF and ABS (all dimensions); PE, PE-X, PB, PP-B and PP-R > 63 mm; multilayer > 32 mm.

^h Only valid for joints with elastomeric-sealing-ring-type sockets.

ⁱ Only valid for PVC-U and PVC-O pipes.

^j Only valid for fittings that incorporate a reduced internal cross section compared to the pipe internal diameter.

^k Only valid for fittings containing brass components.

9.3.3 Requirements

9.3.3.1 Leak tightness under internal pressure (GAS, W, P, I, IS)

When a fitting assembly, assembled in accordance with [9.3.1](#), is tested in accordance with ISO 3458 and [Table 8](#), it shall be leak tight.

Table 8 — Parameters leak tightness under internal pressure

Application	Test medium	Test duration	Test temperature	Test pressure	Requirement
GAS	Air or inert gas	1 h low pressure followed by 1 h high pressure	20 °C ± 5 °C	25 mbar ^a followed by 1,5 × PN	Leak tight
W, P, I, IS	Water	1 h	20 °C ± 5 °C	1,5 × PN	

^a 1 bar = 10⁵ N/m² = 0,1 MPa.

NOTE If the test of GAS is fulfilled, this test covers the requirements of W, P, I and IS.

9.3.3.2 Long-term pressure test for leak tightness under internal pressure (GAS, W, P, I, IS)

When a fitting assembly, assembled in accordance with [9.3.1](#), is tested in accordance with ISO 3458, ISO 1167-1, ISO 1167-4 and [Table 9](#), it shall be leak tight.

Table 9 — Parameters for long-term pressure test for leak tightness under internal pressure

Application	Test medium	Pipe material	Test duration h	Test temperature °C	Test stress ^a MPa	Test pressure	Requirement
GAS	Water	PA 11 160 and PA 12 160 ^b	1 000	20	19,0 ^c		Leak tight
		PA 11 180 and PA 12 180 ^b	1 000	20	20,0 ^c		
		PE 80	1 000	80 ^d	4,0 ^c		
		PE 100	1 000	80 ^d	5,0 ^c		
		PE-X	1 000	95 ^d	4,4 ^c		
		PVC-HI	1 000	20		1,2 × PN ^e	
		Multi-layer	1 000	20		1,2 × PN ^e	
W, P, I, IS	Water	All pipe materials ^{f,g}	1 000	20 ^h		1,2 × PN ^e	

^a Test stress of the pipe.

^b For material classification and designation, see ISO 16486-1:2012, 5.4.

^c If the fitting material is PVC-HI, the test duration will be 1000 h, the test temperature 60 °C and the test pressure 0,4 MPa.

^d If some components of the fitting cannot be tested at 80 °C or 95 °C, another temperature level and the corresponding testing time may be chosen, taking into account the long-term hydrostatic regression curves (e.g. ISO 9080 method for the temperature chosen).

^e PN of the fitting.

^f Declared by the fitting manufacturer.

^g If one of the materials was already tested under the GAS conditions, the W, P, I and IS has not to be repeated for the same pipe material.

^h The test may be carried out at 23 °C ± 2 °C in air.

9.3.3.3 Resistance of plastic pipe/pipe or pipe/fitting assemblies to tensile loading at 23 °C (GAS)

When a fitting assembly, assembled in accordance with 9.3.1, is tested in accordance with ISO 13951, the test force F_T is calculated, in Newtons, from Formula (3):

$$F_T = 2 \times \sigma_T \times \pi \times e_m \times (d_n - e_m) \quad (3)$$

where

σ_T is the applicable test stress given in Annex F (MPa);

e_m is the mean wall thickness of the pipe (mm);

d_n is the nominal outside diameter of the pipe (mm).

None of the following shall occur:

- damage or permanent deformation of the fitting assembly to an extent which would prevent conformity to this standard;
- pull-out of the pipe;

c) leakage before yielding or delamination of the pipe.

Displacement of trapped air from the free space within the fitting assembly, i.e. seal burping, shall not be considered leakage.

9.3.3.4 Resistance to pull-out at 23 °C (W, P, I, IS)

When a fitting assembly, assembled in accordance with 9.3.1, is tested in accordance with ISO 3501, the test force F_T is calculated, in Newtons, from Formula (4):

$$F_T = 1,5 \times \sigma_T \times \pi \times e_m \times (d_n - e_m) \quad (4)$$

where

σ_T is the applicable test stress given in Annex F (MPa);

e_m is the mean wall thickness of the pipe (mm);

d_n is the nominal outside diameter of the pipe (mm).

The test period shall be 1 h.

NOTE If the test of 9.3.3.3 is fulfilled, this test covers the requirements of 9.3.3.4.

None of the following shall occur:

- a) damage or permanent deformation of the fitting assembly to an extent which would prevent conformity to this International Standard (i.e. ISO 17885);
- b) pull-out of the pipe.

9.3.3.5 Resistance to end load at 80 °C (GAS)

When a fitting assembly, assembled in accordance with 9.3.1, is tested in accordance with ISO 19899, the end load force F is calculated, in kN, from Formula (5):

$$F = K \times \frac{MRS \times d_n^2}{SDR^2} \times (SDR - 1) \quad (5)$$

where

K is a mathematical constant equal to $4\pi/10^4$;

MRS is the minimum required strength of the pipe (MPa);

SDR is the standard dimension ratio of the pipe;

d_n is the nominal outside diameter of the pipe (mm).

None of the following shall occur:

- a) damage or permanent deformation of the fitting assembly to an extent which would prevent conformity to this International Standard (i.e. ISO 17885);
- b) pull-out of the pipe;
- c) leakage during a leak tightness test after the constant load test.

Displacement of trapped air from the free space within the fitting assembly, i.e. seal burping, shall not be considered leakage.

If some parts of the fitting cannot be tested at 80 °C, another temperature level shall be chosen, taking into account the long-term hydrostatic regression curves (for example, ISO 9080 for the temperature chosen).

9.3.3.6 Leak tightness after temperature cycling (outside temperature) (GAS)

When a fitting assembly, assembled in accordance with 9.3.1, is tested in accordance with Table 10 and ISO 3458, the assembly shall be leak tight. The leak tightness shall be tested according to 9.3.3.1 after completion of the temperature cycling test. The number of test cycles and the test method (method A or method B) shall be added to the test report.

Table 10 — Parameters leak tightness after temperature cycling (outside temperature)

Application	Test chambers	Test method	Test parameters	Requirement
GAS	Two temperature-regulated chambers	Method A in Annex G	Test medium = air in air Number of test cycles = 10 Internal pressure = 0,375 x PN and maximum 6 bar	Leak tight
	One temperature-regulated chamber	Method B in Annex G	Test medium = air in air Number of test cycles = 10 Internal pressure = 0,375 x PN and maximum 6 bar	

9.3.3.7 Leak tightness under internal pressure when subjected to bending (GAS, W, P, I, IS)

When a fitting assembly, assembled in accordance with 9.3.1, is tested in accordance with ISO 3503, the assembly shall conform to the requirement given in Table 11.

Table 11 — Parameters for leak tightness under internal pressure when subjected to bending

Application	Test medium	Test duration	Test temperature	Bending radius	Test pressure	Requirement
GAS	Air	1 h low pressure followed by 1 h high pressure	23 °C ± 2 °C	For PN ≤ 10; R = 15 × d _n For PN > 10; R = 20 × d _n	25 mbar followed by 1,5 × PN	Leak tight
W, P, I, IS	Water	1 h	23 °C ± 2 °C	For PN ≤ 10; R = 15 × d _n For PN > 10; R = 20 × d _n	1,5 × PN	

NOTE 1 The use of special equipment might be necessary to create the bending radius required for the pipe under test.

NOTE 2 If the test of GAS is fulfilled, this test covers the requirements of W, P, I and IS.

SAFETY PRECAUTION For testing with air above 6 bar, special safety precaution should be taken.

9.3.3.8 Leak tightness under negative pressure (W, P, I, IS)

When a fitting assembly, assembled in accordance with 9.3.1, is tested in accordance with ISO 3459 (by procedure A or B), the assembly shall conform to the requirement given in Table 12. In case of dispute, procedure B shall be used.

Table 12 — Test parameters for negative pressure

Application	Test medium		Test duration	Test temperature	Test pressure difference	Requirement
	Procedure A	Procedure B				
W, P, I, IS	Water outside and air (atmospheric pressure) inside	Air	1 h low pressure difference followed by 1 h high pressure difference	20 °C ± 5 °C	100 ₀ ⁺⁵⁰ mbar (p ₁) followed by (800 ± 50) mbar (p ₂)	Leak tight

9.3.3.9 Leak tightness with angular deflection and deformation (GAS, W, P, I, IS)

When a fitting assembly, assembled in accordance with [9.3.1](#), is tested in accordance with ISO 13845 and ISO 13844, the assembly shall conform to the requirements given in [Table 13](#).

Table 13 — Parameters leak tightness with angular deflection and deformation

Application	Test method	Test medium	Test duration	Test pressure	Test parameters	Requirements	
GAS	ISO 3458	Air	1 h low pressure followed by 1 h high pressure	25 mbar followed by 1,5 × PN	Test temperature: 20 °C ± 5 °C Variation in temperature: ±2 °C	Leak tight	
	followed by						
	ISO 13845 ^a	Air	10 min followed by see Figure 1	25 mbar followed by see Figure 1	Test temperature: 20 °C ± 5 °C Variation in temperature: ±2 °C α see Table 14		
	followed by						
	ISO 13844 ^a	Air	see Figure 2	see Figure 2	Test temperature: 20 °C ± 5 °C Variation in temperature: ±2 °C α see Table 14 5 % deformation in the vertical plane of the pipe at 0,5 d _n from the mouth of the test socket		
	followed by						
ISO 3458	Air	10 min low pressure followed by 10 min high pressure	25 mbar followed by 1,5 × PN	Test temperature: 20 °C ± 5 °C Variation in temperature: ±2 °C			
W, P, I, IS	ISO 13845	Water	see Figure 1	see Figure 1	Test temperature: 20 °C ± 5 °C Variation in temperature: ±2 °C α ≥ 2 ^b	Leak tight	
	ISO 13844	Air	see Figure 2	see Figure 2	Test temperature: 20 °C ± 5 °C Variation in temperature: ±2 °C α ≥ 2 ^b 5 % deformation in the vertical plane of the pipe at 0,5 d _n from the mouth of the test socket ^c	Leak tight	

^a This test is not to be performed on bends and/or reducers with spigot-ends on both sides.

^b If $\alpha_{free} \geq 2^\circ$, firmly anchor the pipe to maintain the deflected pipe in this position for the remainder of the test. If $\alpha_{free} < 2^\circ$, carry out the test at a deflection (α) of 2° measured at the starting point, by forcing the pipe to that position.

^c Only for pipes of series S16 and greater (i.e. thinner walls). For pipes of series less than S16 (i.e. thicker walls), carry out the test without applying the deforming force.

The test pressure p_t shall be calculated by multiplying the factor f indicated in [Figure 1](#) by the nominal pressure PN , i.e. by using Formula (6):

$$p_t = f \times PN \quad (6)$$

NOTE If the test of GAS is fulfilled, this test covers the requirements of W, P, I and IS.

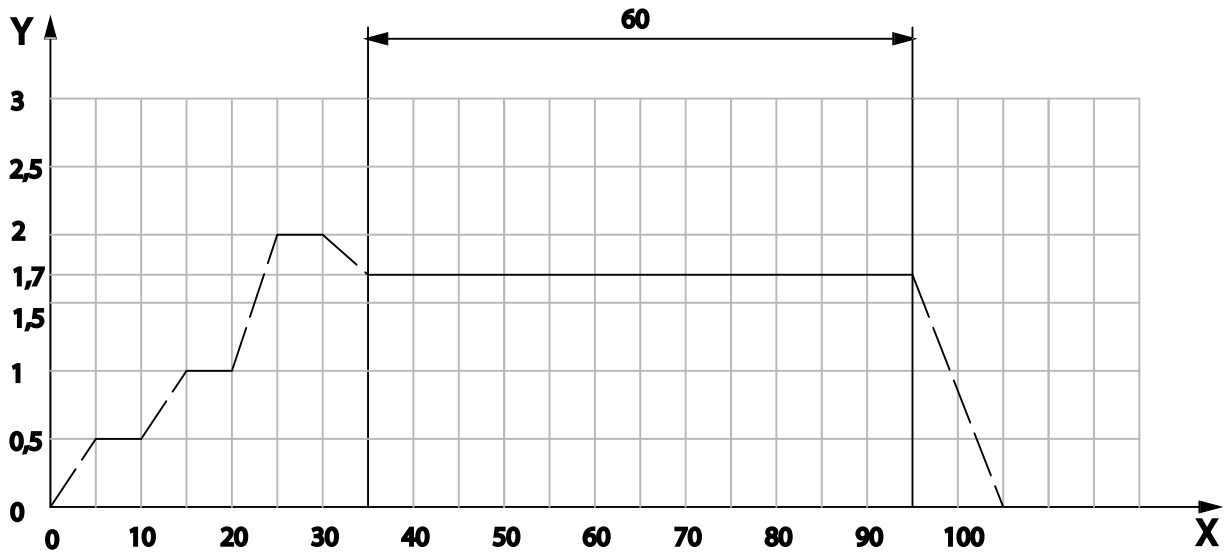

Key

X time, minutes

Y factor f

NOTE The pressure changes need not be at a linear rate.

Figure 1 — Pressure test regime

Table 14 — Angular deflection, α

Nominal outside diameter of connecting pipe d_n mm	α at $10 \times d_n$ from socket-end mm
40	90
50	115
63	145
75	175
90	210
110	255
125	290
140	330
160	370
180	415
200	460
225	520
250	580
315	730
355	820
400	925

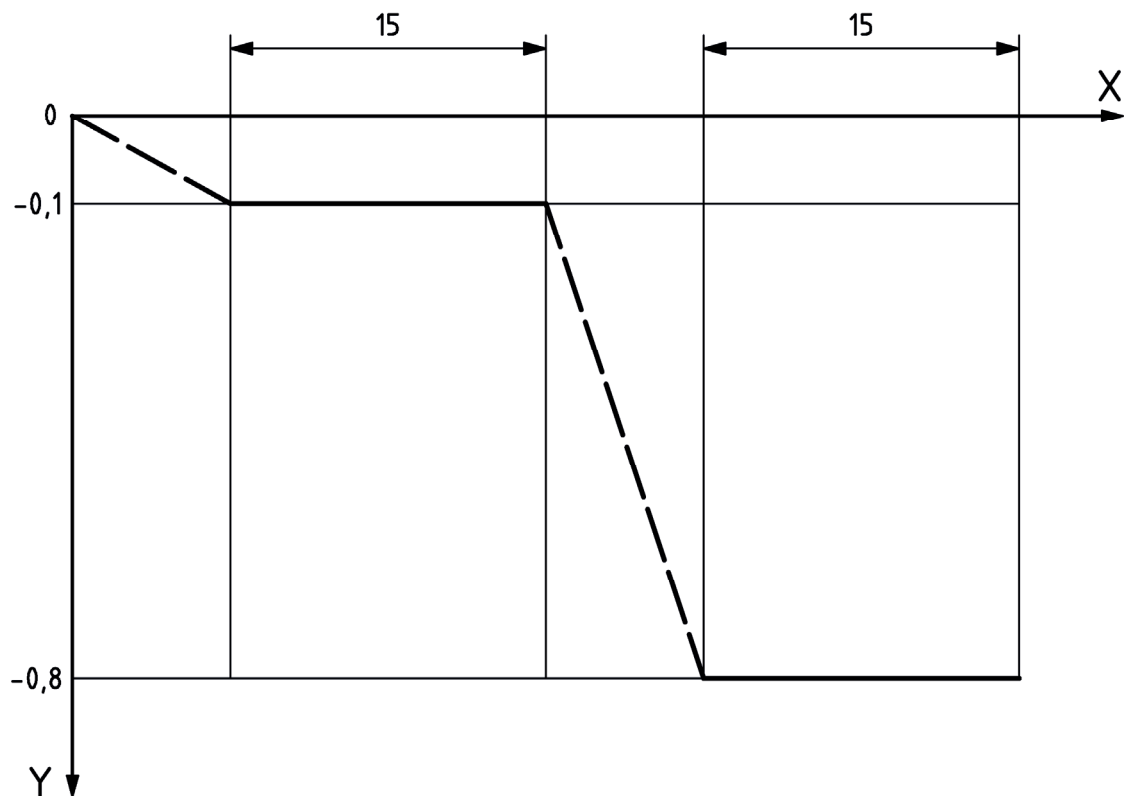

Key

X time, minutes

Y pressure, bar

NOTE The negative pressure changes need not be at linear rate.

Figure 2 — Negative pressure test regime

9.3.3.10 Leak tightness and strength while subjected to bending and internal pressure (W, P, I, IS)

When a fitting assembly with PVC-U or PVC-O pipes and end-load-bearing double sockets, which are provided with elastomeric seals and a locking device (see [Figure 3](#) for a typical example), assembled in accordance with [9.3.1](#), is tested in accordance with ISO 13783, the assembly shall conform to the requirement given in [Table 15](#).

Table 15 — Parameters leak tightness and strength while subjected to bending and internal pressure

Application	Test medium	Test parameters	Requirement
W, P, I, IS	Water	Test temperature: 20 °C ± 5 °C Variation in temperature: ±2 °C	Leak tight

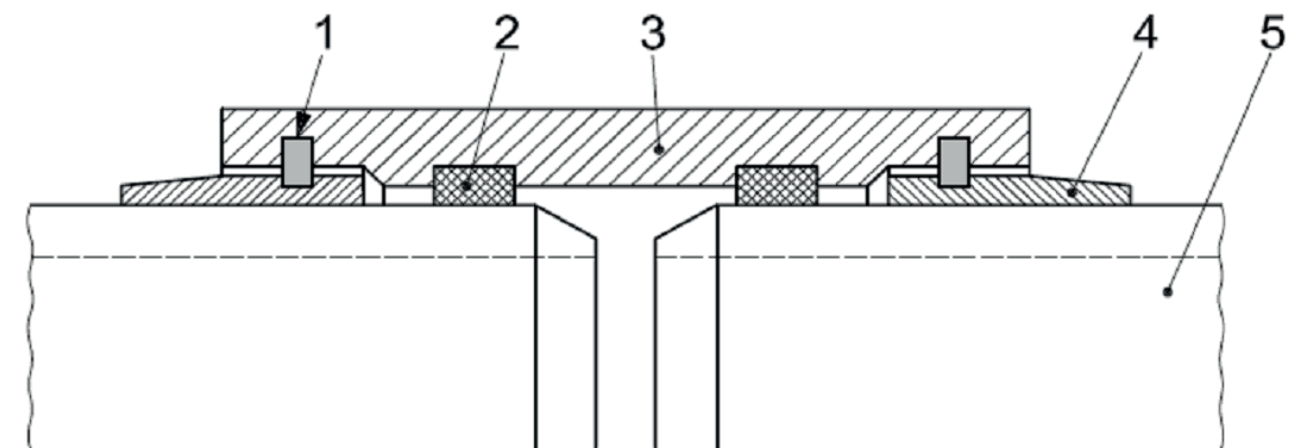

Key

- 1 locking device
- 2 sealing ring
- 3 PVC-U or PVC-O coupling
- 4 solvent cemented PVC-U sleeve
- 5 PVC-U or PVC-O pipe

Figure 3 — Typical example of an end-load-bearing double-socket

9.3.3.11 Flow rate pressure drop relationship (GAS)

The air flow rate at ambient temperature corresponding to a pressure drop across the fitting, as measured when the fitting assembly is tested in accordance with ISO 17778, shall conform to the requirement given in [Table 16](#).

Table 16 — Parameters flow rate pressure drop relationship

Application	Test medium	Test pressure	Pressure drop	Requirement
GAS	Air	25 mbar	for $d_n \leq 63$ mm: 0,5 mbar for $d_n > 63$ mm: 0,1 mbar	Air flow rate (value indicated by the manufacturer)

9.3.3.12 Stress corrosion test (GAS, W, P, I, IS)

When a fitting assembly, assembled in accordance with [9.3.1](#), is tested in accordance with ISO 6957, it shall conform to the requirement given in [Table 17](#).

Table 17 — Parameters stress corrosion

Application	Number of test pieces	pH value of test solution	Requirement
GAS	1	10,0	No cracks
W, P, I, IS	1	9,5	No cracks

NOTE If the test of GAS is fulfilled, this test covers the requirements of W, P, I and IS.

10 Marking

The minimum data for marking is given in [Table 18](#).

Table 18 — Minimum data for marking

Aspects	Marking
Manufacturer's name or trade mark	Name or code
Nominal diameter (in mm)	e.g. 110
Production information	a,b
Body material	e.g. PP-R ^c
Standard number	ISO 17885 ^c
Design pressure	e.g. PN 16 ^b
Intended use	e.g. W ^b
<p>^a In clear figures or in code providing traceability to production period within year and month and the production site if manufacturer is producing at different sites nationally and/or internationally.</p> <p>^b This information may be on the product, on a label attached to the product or on the individual bag.</p> <p>^c This information may be on the packaging.</p>	

11 Packaging

The fitting and the associated components required for its assembly shall be packaged in bulk or individually protected where necessary in order to prevent deterioration and contamination.

The packaging shall have at least information with the manufacturer's name, type and the nominal diameter of the pipe(s), number of units and special storage conditions, if any.

Annex A (informative)

List of standards

A list of standards for plastic pipes for which mechanical fittings is given in [Table A.1](#).

Table A.1 — List of standards

Pipe material	Standard (GAS)	Standard (W, P)	Standard (I)	Standard (IS)
ABS	—	—	—	ISO 15493[7]
PA ^a	ISO 16486-2[8]	—	—	—
PB	—	—	—	ISO 15494[9]
PE 32	—	ISO 4427-2:1996[10]	ISO 8779[12]	—
PE 40	—	ISO 4427-2[11]	ISO 8779[12]	—
PE 63	—	ISO 4427-2[11]	—	ISO 15494[9]
PE 80 PE 100	ISO 4437-2[13]	ISO 4427-2[11]	—	ISO 15494[9]
PE-RT ^b	—	—	—	ISO 15494[9]
PE-X	ISO 14531-1[14]	—	—	ISO 15494[9]
PVC-C	—	—	—	ISO 15493[7]
PVC-HI	ISO 6993-1	—	—	—
PVC-O	—	ISO 16422[15]	ISO 16422[15]	—
PVC-U	—	ISO 1452-2[16]	—	ISO 15493[7]
PP ^c	—	—	—	ISO 15494[9]
PVDF	—	—	—	ISO 10931[17]
Multi-layer	ISO 18225 ^d [18]	ISO 21004[19]	—	—

a PA = PA 11 160, PA 11 180, PA 12 160 or PA 12 180.

b PE-RT = PE-RT type 1 or PE-RT type 2.

c PP = PP-H, PP-B, PP-R or PP-RCT.

d The corresponding International Standard is a system standard.

Annex B **(normative)**

Stiffener requirements

Stiffener shall comply with the following:

- a) The stiffener shall be rigid and provide support over the entire compression area.
- b) There shall be no longitudinal displacement of the stiffener after assembly.
- c) A fitting shall have only one stiffener insert for each combination of diameter and SDR series of the pipe with which it is assembled.
- d) The insertion of the stiffener shall be done according to the manufacturer instructions.
- e) After stiffener installation, the pipe shall show no signs of damage, scratches or cracks to an extent that would prevent conformity to the requirements of this International Standard.
- f) The stiffener material shall be fit for purpose.

Annex C (normative)

Test pressure of materials and fitting bodies

The test pressures of materials and fitting bodies are given in [Table C.1](#)

Table C.1 — Test pressure of materials and fittings bodies

Material	Test temperature	Test duration	σ_{tF}	MRS	σ_s
	°C	h	MPa	MPa	MPa
ABS	20	1	25,0	12,5	8,0
	70	1 000	3,1	12,5	8,0
ECTFE	20	40	26,0	18,4	14,3
	80	170	8,0	18,4	14,3
PA 11 160	20	1 000	19,0	16	8,0
	80	165	10,0	16	8,0
PA 11 180	20	1 000	20,0	18	9,0
	80	165	11,5	18	9,0
PA 12 160	20	1 000	19,0	16	8,0
	80	165	10,0	16	8,0
PA 12 180	20	1 000	20,0	18	9,0
	80	165	11,5	18	9,0
PA 12-GF30	20	1	50,0	20	12,5
	60	1 000	20,0	20	12,5
PA 12-GF50	20	1	50,0	20	12,5
	60	1 000	20,0	20	12,5
PA 12-GF65	20	1	50,0	20	12,5
	60	1 000	20,0	20	12,5
PB	20	1	15,5	12,5	10,0
	95	1 000	6,0	12,5	10,0
PE 80	20	1	11,3	8	6,3
	80	1 000	4,0	8	6,3
PE 100	20	1	13,3	10	8,0
	80	1 000	5,0	10	8,0
PE-RT – Type 1	20	1	9,9	8	6,3
	95	1 000	3,4	8	6,3
PE-RT – Type 2	20	1	10,8	8	6,3
	95	1 000	3,6	8	6,3

^a Valid for design coefficient $C = 1,6$. For other design coefficients, a different design stress σ_s is used. See ISO 16422.[15]

Table C.1 (continued)

Material	Test temperature	Test duration	σ_{tF}	MRS	σ_s
	°C	h	MPa	MPa	MPa
PE-X	20	1	11,0	8	6,3
	95	1 000	4,4	8	6,3
POM-C	20	1	59,0	10	6,3
	95	1 000	6,0	10	6,3
POM-H	20	1	63,0	10	6,3
	60	1 000	10,0	10	6,3
PP-B	20	1	16,0	8	6,3
	95	1 000	2,6	8	6,3
PP-H	20	1	21,0	10	6,3
	95	1 000	3,6	10	6,3
PP-R	20	1	16,0	8	6,3
	95	1 000	3,5	8	6,3
PP-RCT	20	1	15,0	11,2	9,0
	95	1 000	3,8	11,2	9,0
PPSU	20	1	57,1	32	22,4
	95	1 000	21,3	32	22,4
PSU	20	1	66,0	16	11,2
	95	1 000	9,7	16	11,2
PVC-C	20	1	43,0	20	10,0
	60	1 000	16,5	20	10,0
PVC-HI	20	1	30,0	25	10,0
	60	1 000	9,0	25	10,0
PVC-O 315	20	10	40,8	31,5	20,0 ^a
	60	1 000	19,2	31,5	20,0 ^a
PVC-O 355	20	10	46,0	35,5	22,0 ^a
	60	1 000	22,0	35,5	22,0 ^a
PVC-O 400	20	10	52,0	40,0	25,0 ^a
	60	1 000	25,0	40,0	25,0 ^a
PVC-O 450	20	10	60,0	45,0	28,0 ^a
	60	1 000	29,0	45,0	28,0 ^a
PVC-O 500	20	10	65,0	50,0	32,0 ^a
	60	1 000	32,0	50,0	32,0 ^a
PVC-U	20	1	42,0	25	10,0
	60	1 000	10,0	25	10,0
PVDF	20	1	32,6	25	16,0
	95	1 000	11,5	25	16,0

^a Valid for design coefficient $C = 1,6$. For other design coefficients, a different design stress σ_s is used. See ISO 16422.^[15]

Annex D (normative)

Physical characteristics of fitting materials

When determined in accordance with the test method specified in [Table 5](#), using the parameters indicated, the physical characteristics of parts the fittings made of materials shall conform to the requirements given in [Table D.1](#).

Table D.1 — Physical characteristics of parts made of fitting materials

Material	Characteristic	Requirement	Test parameters		Test method
ABS	Vicat softening temperature (VST/B/50 N)	≥90 °C	Conditioning	6 h in air at 80 °C	ISO 306
		And			
		≥70 °C	Conditioning	16 h in water at 90 °C	ISO 306
ECTFE	Melt mass-flow rate (MFR)	0,8 to 1,3	Temperature Load	275 °C 2,16 kg	ISO 1133-1
	Heat deflection temperature	≥90 °C	Load	0,46 MPa	ISO 75-2
PA 11 160 PA 11 180 PA 12 160 PA 12 180	Viscosity number	≥180 ml/g	Solvent	m-Cresol	ISO 307
PA12-GF30 PA12-GF50 PA12-GF65	Viscosity number	≥180 ml/g	Solvent	m-Cresol	ISO 307
PA12-GF30	Ash content	30 ± 2 %	Calcination temperature	850 ± 50 °C ^a	ISO 3451-4
PA12-GF50	Ash content	50 ± 2 %	Calcination temperature	850 ± 50 °C ^a	ISO 3451-4
PA12-GF65	Ash content	65 ± 2 %	Calcination temperature	850 ± 50 °C ^a	ISO 3451-4

^a If at that temperature glass fibres present become molten and thus prevent further calcinations of the polymer, lower the temperature of calcinations to (600 ± 25) °C and repeat the procedure with a fresh test portion.

^b Not applicable for outerlayer material introduced to facilitate fusion jointing.

^c A tolerance of ±5 % shall apply to manufacturer's nominated value at any point in the body of the fitting.

^d Samples of radial thickness 0,1 mm to be used for measurement of gel content. Samples to be taken at least from the outer and inner surfaces of the PE-X fitting and the mid-wall position.

^e To be carried out on feedstock fitting material or on reverted fitting.

^f The weld-line is likely to become more pronounced, but this should not be taken as a sign of weld-line splitting.

^g For sprue-gating, the area of the injection point shall be calculated using a radius $R = 0,3d_n$ with a maximum value of 50 mm. For fittings moulded by end-gating techniques, e.g. ring or diaphragm methods, the gating area shall be a cylindrical portion with a length of $L = 0,3d_n$ with a maximum value of 50 mm (see [Figure D.1](#)). Any cracks or delamination in the wall of the fitting within to the injection area, parallel to the axis of the fitting, shall not penetrate in the axial direction more than 20 % of the length L defined in this note.

Table D.1 (continued)

Material	Characteristic	Requirement	Test parameters		Test method
PB	Melt mass-flow rate (MFR)	After processing maximum deviation of $\pm 20\%$ of the value measured on the batch used to manufacture the fitting	Temperature Load	190 °C 5 kg or 2,16 kg	ISO 1133-1
PE 80 PE 100 PE-RT type 1 PE-RT type 2	Melt mass-flow rate (MFR)	After processing maximum deviation of $\pm 20\%$ of the value measured on the batch used to manufacture the fitting	Temperature Load	190 °C 5 kg or 21,6 kg	ISO 1133-1
PE-X ^b	Degree of crosslinking	Crosslinking process: Peroxide $\geq 70\%$ ^c Silane $\geq 65\%$ ^c Electron beam $\geq 60\%$ ^c	Media Time	Boiling xylene 8 h \pm 30 min.	ISO 10147 ^d
POM	Melt mass-flow rate (MFR)	≤ 4 g/10 min	Temperature Load	190 °C 2,16 kg	ISO 1133-1
PP-B PP-H PP-R PP-RCT	Melt mass-flow rate (MFR)	After processing maximum deviation of $\pm 30\%$ of the value measured on the batch used to manufacture the fitting	Temperature Load Temperature Load	230 °C 2,16 kg Alternative condition: 190 °C 5 kg	ISO 1133-1
PPSU	Melt mass-flow rate (MFR)	After processing maximum deviation of $\pm 30\%$ of the value measured on the batch used to manufacture the fitting	Temperature Load Temperature Load	365 °C 5 kg Alternative condition: 360 °C 10 kg	ISO 1133-1

^a If at that temperature glass fibres present become molten and thus prevent further calcinations of the polymer, lower the temperature of calcinations to (600 ± 25) °C and repeat the procedure with a fresh test portion.

^b Not applicable for outerlayer material introduced to facilitate fusion jointing.

^c A tolerance of $\pm 5\%$ shall apply to manufacturer's nominated value at any point in the body of the fitting.

^d Samples of radial thickness 0,1 mm to be used for measurement of gel content. Samples to be taken at least from the outer and inner surfaces of the PE-X fitting and the mid-wall position.

^e To be carried out on feedstock fitting material or on reverted fitting.

^f The weld-line is likely to become more pronounced, but this should not be taken as a sign of weld-line splitting.

^g For sprue-gating, the area of the injection point shall be calculated using a radius $R = 0,3d_n$ with a maximum value of 50 mm. For fittings moulded by end-gating techniques, e.g. ring or diaphragm methods, the gating area shall be a cylindrical portion with a length of $L = 0,3d_n$ with a maximum value of 50 mm (see [Figure D.1](#)). Any cracks or delamination in the wall of the fitting within to the injection area, parallel to the axis of the fitting, shall not penetrate in the axial direction more than 20 % of the length L defined in this note.

Table D.1 (continued)

Material	Characteristic	Requirement	Test parameters		Test method
PSU	Melt mass-flow rate (MFR)	After processing maximum deviation of $\pm 30\%$ of the value measured on the batch used to manufacture the fitting	Temperature Load Temperature Load	343 °C 2,16 kg Alternative condition: 360 °C 2,16 kg	ISO 1133-1
PVC-C	Vicat softening temperature	≥ 103 °C	Shall conform to ISO 2507-2		ISO 2507-1
PVC-HI PVC-U	Vicat softening temperature	≥ 74 °C	Shall conform to ISO 2507-2		ISO 2507-1
PVC-O	Vicat softening temperature	≥ 80 °C	Shall conform to ISO 2507-2		ISO 2507-1
PVC-C PVC-O ^e PVC-U	Effects of heating	The fittings shall not show any blisters or signs of weld-line splitting. ^f No surface damage in the area of any injection point shall penetrate deeper than 30 % of e at that point for $d_n < 75$ mm and 50 % for $d_n > 63$ mm. Outside the area of any injection point no surface damage shall occur. ^g	Test temperature Test period for: $e \leq 3$ $3 < e \leq 10$ $10 < e \leq 20$ $20 < e \leq 30$ $30 < e \leq 40$ $40 < e$ Number of test pieces	(150 \pm 2) °C 15 min 30 min 60 min 140 min 220 min 240 min 3	ISO 580:2005 Method A
PVC-HI	Effects of heating	See ISO 6993-2 and ISO 6993-3	Test temperature Test period for: $e \leq 3$ $3 < e \leq 10$ $10 < e \leq 20$ $20 < e \leq 30$ $30 < e \leq 40$ $40 < e$ Number of test pieces	(150 \pm 2) °C 15 min 30 min 60 min 140 min 220 min 240 min 3	ISO 580:2005 Method A

^a If at that temperature glass fibres present become molten and thus prevent further calcinations of the polymer, lower the temperature of calcinations to (600 \pm 25) °C and repeat the procedure with a fresh test portion.

^b Not applicable for outerlayer material introduced to facilitate fusion jointing.

^c A tolerance of $\pm 5\%$ shall apply to manufacturer's nominated value at any point in the body of the fitting.

^d Samples of radial thickness 0,1 mm to be used for measurement of gel content. Samples to be taken at least from the outer and inner surfaces of the PE-X fitting and the mid-wall position.

^e To be carried out on feedstock fitting material or on reverted fitting.

^f The weld-line is likely to become more pronounced, but this should not be taken as a sign of weld-line splitting.

^g For sprue-gating, the area of the injection point shall be calculated using a radius $R = 0,3d_n$ with a maximum value of 50 mm. For fittings moulded by end-gating techniques, e.g. ring or diaphragm methods, the gating area shall be a cylindrical portion with a length of $L = 0,3d_n$ with a maximum value of 50 mm (see [Figure D.1](#)). Any cracks or delamination in the wall of the fitting within to the injection area, parallel to the axis of the fitting, shall not penetrate in the axial direction more than 20 % of the length L defined in this note.

Table D.1 (continued)

Material	Characteristic	Requirement	Test parameters		Test method
PVDF	Melt mass-flow rate (MFR)	After processing maximum deviation of ± 20 % of the value measured on the batch used to manufacturer the fitting	Temperature Load	230 °C 5 kg	ISO 1133-1
	Vicat softening temperature	≥ 125 °C	Load	1 kg	ISO 306
Cu alloys	Dezincification resistance	The maximum measured dezincification accepted is 100 μm in the tangential direction. The maximum measured dezincification accepted is 200 μm in the axial direction.	Exposed area Test temperature Test duration	~ 100 mm ² (75 \pm 5)°C 24 h	ISO 6509
<p>a If at that temperature glass fibres present become molten and thus prevent further calcinations of the polymer, lower the temperature of calcinations to (600 \pm 25) °C and repeat the procedure with a fresh test portion.</p> <p>b Not applicable for outerlayer material introduced to facilitate fusion jointing.</p> <p>c A tolerance of ± 5 % shall apply to manufacturer's nominated value at any point in the body of the fitting.</p> <p>d Samples of radial thickness 0,1 mm to be used for measurement of gel content. Samples to be taken at least from the outer and inner surfaces of the PE-X fitting and the mid-wall position.</p> <p>e To be carried out on feedstock fitting material or on reverted fitting.</p> <p>f The weld-line is likely to become more pronounced, but this should not be taken as a sign of weld-line splitting.</p> <p>g For sprue-gating, the area of the injection point shall be calculated using a radius $R = 0,3d_n$ with a maximum value of 50 mm. For fittings moulded by end-gating techniques, e.g. ring or diaphragm methods, the gating area shall be a cylindrical portion with a length of $L = 0,3d_n$ with a maximum value of 50 mm (see Figure D.1). Any cracks or delamination in the wall of the fitting within to the injection area, parallel to the axis of the fitting, shall not penetrate in the axial direction more than 20 % of the length L defined in this note.</p>					

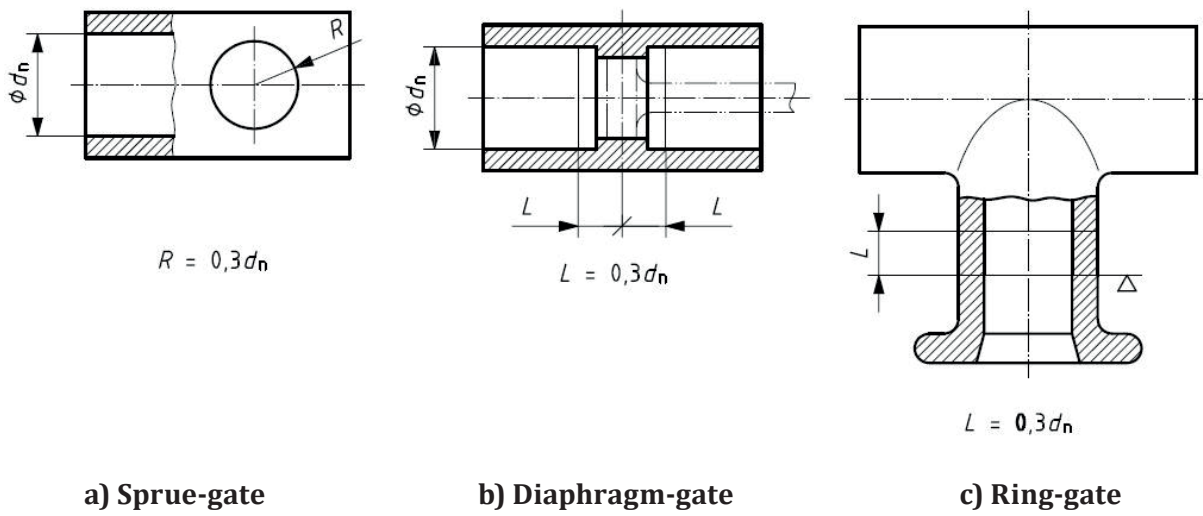

Figure D.1 — Injection gating areas

Annex E (normative)

Resistance to gas constituents

This test method applies to PE and PE-X materials and can be used as guideline for other materials. The test shall be carried out on 32 mm SDR 11 pipe. The test may be carried out on other sizes, provided that there is a clear correlation to the results on the 32 mm SDR 11 pipe.

Prepare a synthetic condensate comprising a mixture of a 50 % mass fraction of *n*-decane (99 %) and a 50 % mass fraction of 1-3-5-trimethylbenzene.

Condition the pipe by filling it with condensate and allowing it to stand in air for 1 500 h at (23 ± 2) °C. Carry out the test in accordance with ISO 1167-1 and ISO 1167-2, but using the synthetic condensate inside the pipe at elevated temperature.

Annex F (normative)

Test stresses

The test stresses depending on the pipe materials and intended application are given in [Table F.1](#); see [9.3.3.3](#) and [9.3.3.4](#).

Table F.1 — Test stresses depending on pipe materials

Pipe material	Application		Test stress MPa
	GAS	W, P, IS, I	
ABS	—	X	12,5 ^a
ECTFE	—	X	13,0 ^b
PA 11 160	X	—	9,5 ^c
PA 11 180	X	—	10,0 ^c
PA 12 160	X	—	9,5 ^c
PA 12 180	X	—	10,0 ^c
PB	—	X	7,7 ^a
PE32	—	X	2,8 ^a
PE40	—	X	3,3 ^a
PE63	—	X	4,5 ^a
PE80	X	X	5,7 ^a
PE100	X	X	6,6 ^a
PE-RT – Type 1	—	X	4,9 ^a
PE-RT – Type 2	—	X	5,4 ^a
PE-X	X	X	5,5 ^a
PP-B	—	X	8,0 ^a
PP-H	—	X	10,5 ^a

X = applicable,
— = not applicable.

^a These are longitudinal stresses, and their values are therefore half those of the circumferential stresses given as hoop stresses for 1 h at 20 °C.

^b These are longitudinal stresses, and their values are therefore half those of the circumferential stresses given as hoop stresses for 40 h at 20 °C.

^c These are longitudinal stresses, and their values are therefore half those of the circumferential stresses given as hoop stresses for 1000 h at 20 °C.

^d These are longitudinal stresses, and their values are therefore half those of the circumferential stresses given as hoop stresses for 10 h at 20 °C.

^e Where:

p_t is the calculated pressure and is half of the value of the pressure (bar) at 1 h at 20 °C. This can be calculated by the following:

a) using the formula from ISO 17456:2006, Annex A, if the long-term pressure strength is calculated with Procedure I: “Calculation method” (multilayer P pipes);

b) from reference curve from ISO 17456:2006, if the long-term pressure strength is determined with Procedure II: “Pressure test” (multilayer M and P pipes).

Table F.1 (continued)

Pipe material	Application		Test stress MPa
	GAS	W, P, IS, I	
PP-R	—	X	8,0 ^a
PP-RCT	—	X	7,5 ^a
PVC-C	—	X	21,5 ^a
PVC-HI	X	X	15,0 ^a
PVC-O 315	—	X	20,4 ^d
PVC-O 355	—	X	23,0 ^d
PVC-O 400	—	X	26,0 ^d
PVC-O 450	—	X	30,0 ^d
PVC-O 500	—	X	32,5 ^d
PVC-U	—	X	21,0 ^a
PVDF	—	X	16,3 ^a
Multi-layer	X	X	$\sigma_T = \frac{p_t \times (d_n - e_n)}{20 \times e_n}^e$

X = applicable,

— = not applicable.

^a These are longitudinal stresses, and their values are therefore half those of the circumferential stresses given as hoop stresses for 1 h at 20 °C.

^b These are longitudinal stresses, and their values are therefore half those of the circumferential stresses given as hoop stresses for 40 h at 20 °C.

^c These are longitudinal stresses, and their values are therefore half those of the circumferential stresses given as hoop stresses for 1000 h at 20 °C.

^d These are longitudinal stresses, and their values are therefore half those of the circumferential stresses given as hoop stresses for 10 h at 20 °C.

^e Where:

p_t is the calculated pressure and is half of the value of the pressure (bar) at 1 h at 20 °C. This can be calculated by the following:

a) using the formula from ISO 17456:2006, Annex A, if the long-term pressure strength is calculated with Procedure I: "Calculation method" (multilayer P pipes);

b) from reference curve from ISO 17456:2006, if the long-term pressure strength is determined with Procedure II: "Pressure test" (multilayer M and P pipes).

Annex G (normative)

Cyclic test procedure

[Table G.1](#) gives the cyclic test procedure for leak tightness after temperature cycling (outside temperature; see [9.3.3.6](#)).

Table G.1 — Cyclic test procedure

Test method	Cyclic test procedure
Method A	i. place the fitting assembly in the first chamber at $T_{\min}^a \pm 2 \text{ }^\circ\text{C}$ and leave it there for at least 2,5 h; ii. transfer the fitting assembly to the second chamber at $T_{\max}^a \pm 2 \text{ }^\circ\text{C}$; the minimum transfer time shall be 0,5 h and the maximum 1 h; iii. leave the fitting assembly in the second chamber at $T_{\max}^a \pm 2 \text{ }^\circ\text{C}$ for at least 2,5 h; iv. transfer the fitting assembly to the first chamber at $T_{\min}^a \pm 2 \text{ }^\circ\text{C}$; the minimum transfer time shall be 0,5 h and the maximum 1 h; v. return to i).
Method B	i. increase the temperature of the chamber to $T_{\max}^a \pm 2 \text{ }^\circ\text{C}$ at a minimum rate of $1 \text{ }^\circ\text{C}/\text{min}$; ii. maintain at $T_{\max}^a \pm 2 \text{ }^\circ\text{C}$ for at least 2 h; iii. reduce the temperature to $T_{\min}^a \pm 2 \text{ }^\circ\text{C}$ at a minimum rate of $1 \text{ }^\circ\text{C}/\text{min}$; iv. maintain at $T_{\min}^a \pm 2 \text{ }^\circ\text{C}$ for at least 2 h; v. return to i).
^a T_{\max} and T_{\min} are installation temperatures as declared by the manufacturer; see Clause 4 .	

Bibliography

- [1] ISO 3, *Preferred numbers — Series of preferred numbers*
- [2] ISO 497, *Guide to the choice of series of preferred numbers and of series containing more rounded values of preferred numbers*
- [3] CEN/TR 15438, *Plastics piping systems — Guidance for coding of products and their intended uses*
- [4] EN 377, *Lubricants for applications in appliances and associated controls using combustible gases except those designed for use in industrial processes*
- [5] ISO/TR 10358, *Plastics pipes and fittings — Combined chemical-resistance classification table*
- [6] ISO/TR 7620, *Rubber materials — Chemical resistance*
- [7] ISO 15493, *Plastics piping systems for industrial applications — Acrylonitrile-butadiene-styrene (ABS), unplasticized poly(vinyl chloride) (PVC-U) and chlorinated poly(vinyl chloride) (PVC-C) — Specifications for components and the system — Metric series*
- [8] ISO 16486-2, *Plastics piping systems for the supply of gaseous fuels - Unplasticized polyamide (PA-U) piping systems with fusion jointing and mechanical jointing — Part 2: Pipes*
- [9] ISO 15494, *Plastics piping systems for industrial applications – Polybutene (PB), polyethylene (PE) and polypropylene (PP) – Specifications for components and the system – Metric series*
- [10] ISO 4427-2:1996, *Plastics piping systems – Polyethylene (PE) pipes and fittings for water supply – Part 2: Pipes*
- [11] ISO 4427-2, *Plastics piping systems — Polyethylene (PE) pipes and fittings for water supply — Part 2: Pipes*
- [12] ISO 8779, *Plastics piping systems — Polyethylene (PE) pipes for irrigation — Specifications*
- [13] ISO 4437-2, *Plastics piping systems for the supply of gaseous fuels - Polyethylene (PE) — Part 2: Pipes*
- [14] ISO 14531-1, *Plastics pipes and fittings — Crosslinked polyethylene (PE-X) pipe systems for the conveyance of gaseous fuels — Metric series — Specifications — Part 1: Pipes*
- [15] ISO 16422, *Pipes and joints made of oriented unplasticized poly(vinyl chloride) (PVC-O) for the conveyance of water under pressure — Specifications*
- [16] ISO 1452-2, *Plastics piping systems for water supply and for buried and above-ground drainage and sewerage under pressure — Unplasticized poly(vinyl chloride) (PVC-U) — Part 2: Pipes*
- [17] ISO 10931, *Plastics piping systems for industrial applications — Poly(vinylidene fluoride) (PVDF) — Specifications for components and the system*
- [18] ISO 18225, *Plastics piping systems — Multilayer piping systems for outdoor gas installations — Specifications for systems*
- [19] ISO 21004, *Plastics piping systems — Multilayer pipes and their joints, based on thermoplastics, for water supply*
- [20] ISO 1083, *Spheroidal graphite cast irons — Classification*
- [21] ISO 5922:2005, *Malleable cast iron*

