

Founding — Ausferritic spheroidal graphite cast irons — Classification

ICS 77.080.10

National foreword

This British Standard reproduces verbatim ISO 17804:2005 and implements it as the UK national standard.

The UK participation in its preparation was entrusted to Technical Committee ISE/35, Cast iron, which has the responsibility to:

- aid enquirers to understand the text;
- present to the responsible international/European committee any enquiries on the interpretation, or proposals for change, and keep UK interests informed;
- monitor related international and European developments and promulgate them in the UK.

A list of organizations represented on this committee can be obtained on request to its secretary.

Cross-references

The British Standards which implement international publications referred to in this document may be found in the *BSI Catalogue* under the section entitled “International Standards Correspondence Index”, or by using the “Search” facility of the *BSI Electronic Catalogue* or of British Standards Online.

This publication does not purport to include all the necessary provisions of a contract. Users are responsible for its correct application.

Compliance with a British Standard does not of itself confer immunity from legal obligations.

Summary of pages

This document comprises a front cover, an inside front cover, the ISO title page, pages ii to vi, pages 1 to 30, an inside back cover and a back cover.

The BSI copyright notice displayed in this document indicates when the document was last issued.

Amendments issued since publication

Amd. No.	Date	Comments

This British Standard was published under the authority of the Standards Policy and Strategy Committee on 25 January 2006

© BSI 25 January 2006

INTERNATIONAL
STANDARD

ISO
17804

First edition
2005-11-01

**Founding — Ausferritic spheroidal
graphite cast irons — Classification**

Fonderie — Fonte ausferritique à graphite sphéroïdal — Classification



Reference number
ISO 17804:2005(E)

Contents	Page
Foreword.....	v
Introduction	vi
1 Scope	1
2 Normative references	1
3 Terms and definitions.....	2
4 Designation	2
5 Order information	2
6 Manufacture.....	3
7 Requirements	3
7.1 General.....	3
7.2 Test pieces machined from separately cast and cast-on samples	3
7.3 Test pieces machined from samples cut from a casting.....	3
7.4 Hardness.....	5
7.5 Graphite structure.....	5
7.6 Matrix structure.....	5
8 Sampling	5
8.1 General.....	5
8.2 Separately cast samples	5
8.3 Cast-on samples	6
8.4 Samples cut from a casting	7
9 Test methods.....	8
9.1 Tensile test	8
9.2 Impact test, Charpy V	8
9.3 Hardness test	8
10 Retests	8
10.1 Need for retesting	8
10.2 Test validity	9
10.3 Non-conforming test results.....	9
10.4 Heat treatment of samples and castings.....	9
11 Additional information.....	9
Annex A (normative) Abrasion-resistant grades of ausferritic spheroidal graphite cast iron.....	16
Annex B (normative) Minimum elongation values for a test piece with original gauge length <i>L₀ = 4 × d</i>	18
Annex C (informative) Guidance values for Brinell hardness	19
Annex D (informative) Procedure for the determination of the hardness range	20
Annex E (informative) Guidance values for tensile strength and elongation for test pieces machined from samples cut from a casting [1]	21
Annex F (informative) Unnotched impact test.....	22
Annex G (informative) Additional information on mechanical and physical properties.....	24
Annex H (informative) Nodularity (or spheroidal graphite rate)	26
Annex I (informative) Machinability of ausferritic spheroidal graphite cast irons	27

Annex J (informative) Cross-references of similar grades of ausferritic spheroidal graphite cast iron..... 29

Bibliography 30

Foreword

ISO (the International Organization for Standardization) is a worldwide federation of national standards bodies (ISO member bodies). The work of preparing International Standards is normally carried out through ISO technical committees. Each member body interested in a subject for which a technical committee has been established has the right to be represented on that committee. International organizations, governmental and non-governmental, in liaison with ISO, also take part in the work. ISO collaborates closely with the International Electrotechnical Commission (IEC) on all matters of electrotechnical standardization.

International Standards are drafted in accordance with the rules given in the ISO/IEC Directives, Part 2.

The main task of technical committees is to prepare International Standards. Draft International Standards adopted by the technical committees are circulated to the member bodies for voting. Publication as an International Standard requires approval by at least 75 % of the member bodies casting a vote.

Attention is drawn to the possibility that some of the elements of this document may be the subject of patent rights. ISO shall not be held responsible for identifying any or all such patent rights.

ISO 17804 was prepared by Technical Committee ISO/TC 25, *Cast irons and pig irons*, Subcommittee SC 2, *Spheroidal graphite cast irons*.

Introduction

Ausferritic spheroidal graphite cast iron is a cast alloy, iron and carbon based, carbon being present mainly in the form of spheroidal graphite particles.

Compared with the spheroidal graphite cast-iron grades (see ISO 1083:2004), this material combines higher strength and toughness properties as a result of the austempering heat treatment.

This International Standard deals with the classification of ausferritic spheroidal graphite cast irons in accordance with the mechanical properties of the material.

The mechanical properties of these ausferritic spheroidal graphite cast irons depend on their structure, e.g. the form of the graphite and the structure of the matrix.

The required structure is developed by selecting the appropriate composition and subsequent processing.

The mechanical properties of the material can be evaluated on machined test pieces prepared from:

- separately cast samples with an appropriate gating system, able to provide metallurgical conditions similar to those of the castings they represent;
- samples cast onto either the casting or the running system, hereafter referred to as cast-on samples;
- samples cut from a casting (only by agreement between the manufacturer and the purchaser, the agreement specifying, in particular, the conditions of sampling and the values to be obtained).

Two grades of ausferritic spheroidal graphite cast iron are specified in Annex A, in accordance with their hardness. These cast irons are used in applications (e.g. mining, earth moving and manufacturing industries) where high abrasion resistance is required.

Five grades of ausferritic spheroidal graphite cast iron are specified by the mechanical properties. When, for these grades, hardness is a requirement for the application, Annex D provides means for determining appropriate hardness ranges.

Founding — Ausferritic spheroidal graphite cast irons — Classification

1 Scope

This International Standard defines the grades and the corresponding requirements for ausferritic spheroidal graphite cast irons.

This International Standard specifies five grades of ausferritic spheroidal graphite cast iron by a classification based on mechanical properties measured on machined test pieces prepared from:

- separately cast samples or cast-on samples;
- samples cut from a casting.

This International Standard also specifies two grades by a classification as a function of hardness.

2 Normative references

The following referenced documents are indispensable for the application of this document. For dated references, only the edition cited applies. For undated references, the latest edition of the referenced document (including any amendments) applies.

ISO 148-1, *Metallic materials — Charpy pendulum impact test — Part 1: Test method*

ISO 148-2, *Metallic materials — Charpy pendulum impact test — Part 2: Verification of test machines*

ISO 148-3, *Metallic materials — Charpy pendulum impact test — Part 3: Preparation and characterization of Charpy V reference test pieces for verification of test machines*

ISO 945, *Cast iron — Designation of microstructure of graphite*

ISO 6506-1, *Metallic materials — Brinell hardness test — Part 1: Test method*

ISO 6507-1, *Metallic materials — Vickers hardness test — Part 1: Test method*

ISO 6892, *Metallic materials — Tensile testing at ambient temperature*

ISO/TR 15931, *Designation system for cast irons and pig irons*

3 Terms and definitions

For the purposes of this document, the following terms and definitions apply.

3.1

ausferritic spheroidal graphite cast iron

cast material, iron and carbon based, carbon being present mainly in the form of spheroidal graphite particles, subjected to an austemper heat treatment in order to produce an ausferritic matrix

NOTE Ausferritic spheroidal graphite cast iron is also known as austempered ductile iron (ADI).

3.2

graphite spheroidising treatment

process which brings the liquid iron into contact with a substance to produce graphite in spheroidal form during solidification

3.3

austemper heat treatment of spheroidal graphite cast iron

process, consisting of heating the castings above the A_{C1} temperature (at which austenite starts to form during heating), cooling at a rate sufficient to avoid the formation of pearlite, and transforming the matrix structure for a time and a temperature (above the martensite start temperature) sufficient to produce the desired properties

NOTE This process produces a microstructure that consists predominantly of ferrite and austenite. This microstructure is called ausferrite.

3.4

relevant wall thickness

section of the casting, agreed between the manufacturer and the purchaser, to which the determined mechanical properties apply

NOTE Relevant wall thickness may be associated with a range of casting sections and/or with a sample type and size according to Table 3. The association is made by considering the cooling conditions during solidification and heat treatment.

4 Designation

The material shall be designated in accordance with ISO/TR 15931.

Annex J gives a selection of approximate cross-references of grade designations in this International Standard to standard grades from EN, ASTM, JIS and SAE standards.

5 Order information

The following information shall be supplied by the purchaser:

- a) the complete designation of the material;
- b) any special requirements.

All agreements shall be made between the manufacturer and the purchaser by the time of acceptance of the order.

6 Manufacture

The method of producing ausferritic spheroidal graphite cast iron, its chemical composition and heat treatment, shall be left to the discretion of the manufacturer, who shall ensure that the casting process and heat treatment process are carried out with the same process parameters as the approved first samples.

7 Requirements

7.1 General

The property values for these materials apply to castings cast in sand moulds or moulds of comparable thermal behaviour. Subject to amendments to be agreed upon in the order, they can apply to castings obtained by alternative methods.

The material designation is based on the minimum mechanical properties obtained in separately cast or cast-on samples, cast in a sand mould or a mould of comparable thermal behaviour, corresponding to a relevant wall thickness $12,5 \text{ mm} < t \leq 30 \text{ mm}$, as given in Table 1.

NOTE Mechanical properties for test pieces cut from a casting are affected not only by material properties (a subject of this International Standard), but also by the local casting soundness (not a subject of this International Standard). Tensile testing requires sound test bars in order to guarantee pure uniaxial stress during the test.

7.2 Test pieces machined from separately cast and cast-on samples

7.2.1 General

The mechanical properties of ausferritic spheroidal graphite cast iron shall be as specified in Table 1 and, if applicable, in accordance with the requirements given in 7.2.2.

7.2.2 Impact test

The impact-resistance values given in Table 2 at room temperature, if applicable, shall only be determined if specified by the purchaser by the time of acceptance of the order.

7.3 Test pieces machined from samples cut from a casting

If applicable, the manufacturer and the purchaser shall agree on:

- the location(s) on a casting where the sample(s) shall be taken;
- the mechanical properties that shall be measured;
- the minimum values (or allowable range of values) for these mechanical properties (for information, see Annex E).

NOTE 1 The properties of castings are not uniform, depending on the complexity of the castings and variation in their section thickness.

NOTE 2 Tables 1 and 2 may be used for guidance on the likely mechanical properties of the castings. These properties may be equal to or lower than those given in these tables.

Table 1 — Mechanical properties measured on test pieces machined from separately cast samples or cast-on samples [1]

Material designation	Relevant wall thickness of the casting	Tensile strength	0,2 % proof strength	Elongation
	<i>t</i> mm	R_m N/mm ² min.	$R_{p0,2}$ N/mm ² min.	<i>A</i> % min.
ISO 17804/JS/800-10 ISO 17804/JS/800-10RT	$t \leq 30$ $30 < t \leq 60$ $60 < t \leq 100$	800 750 720	500	10 6 5
ISO 17804/JS/900-8	$t \leq 30$ $30 < t \leq 60$ $60 < t \leq 100$	900 850 820	600	8 5 4
ISO 17804/JS/1050-6	$t \leq 30$ $30 < t \leq 60$ $60 < t \leq 100$	1 050 1 000 970	700	6 4 3
ISO 17804/JS/1200-3	$t \leq 30$ $30 < t \leq 60$ $60 < t \leq 100$	1 200 1 170 1 140	850	3 2 1
ISO 17804/JS/1400-1	$t \leq 30$ $30 < t \leq 60$ $60 < t \leq 100$	1 400 1 170 1 140	1 100	1
			To be agreed between the manufacturer and the purchaser	

NOTE 1 The properties of castings are not uniform because of the complexity and variation in section thickness.

NOTE 2 With the appropriate heat treatment, the specified minimum 0,2 % proof strength values according to this table can be maintained. However, with increasing casting wall thickness, the tensile strength and elongation values will decrease.

NOTE 3 1 N/mm² = 1 MPa.

NOTE 4 If the type of sample is to be specified, a “/” is added to the designation, followed by a letter indicating the type of sample:
— S for a separately cast sample;
— U for a cast-on sample.

Table 2 — Minimum impact-resistance values measured on V-notched test pieces machined from separately cast samples or cast-on samples [1]

Material designation	Relevant wall thickness of the casting <i>t</i> mm	Minimum impact-resistance value at room temperature (23 ± 5 °C)	
		Mean value of 3 tests J	Individual value J
ISO 17804/JS/800-10RT	$t \leq 30$	10	9
	$30 < t \leq 60$	9	8
	$60 < t \leq 100$	8	7

NOTE If the type of sample is to be specified, a “/” is added to the designation, followed by a letter indicating the type of sample:
— S for a separately cast sample;
— U for a cast-on sample.

7.4 Hardness

Guidance values for the Brinell hardness range of the material grades are given in Annex C.

7.5 Graphite structure

The graphite structure shall be mainly of form V and VI in accordance with ISO 945. A more precise definition may be agreed upon by the time of acceptance of the order.

This structure shall be confirmed either by metallographic examination or by non-destructive methods. In case of dispute, the results of the microscopic examination shall prevail.

Additional information regarding nodularity is given in Annex H.

7.6 Matrix structure

The matrix structure of the various grades of ausferritic spheroidal graphite cast iron consists predominantly of ferrite and austenite, otherwise known as ausferrite. Other matrix constituents (e.g. martensite, carbides) may be present at a level that will not affect the required mechanical properties.

The cooling rate within some sections may not be sufficient to avoid the formation of pearlite or other high-temperature transformation products. In such cases, the maximum acceptable quantities of these micro-constituents, the locations within the casting, and the mechanical properties in these locations may be agreed upon between the manufacturer and the purchaser.

An indirect method to determine if the required microstructure after the heat treatment has been obtained is the impact testing of unnotched Charpy test samples.

The minimum impact energy values to be obtained and details of the unnotched Charpy impact test are given in Annex F.

8 Sampling

8.1 General

Samples shall be provided to represent the castings produced.

Samples shall be made from the same material as that used to produce the castings which they represent.

The same melt and heat treatment processes shall be applied.

Several types of samples (separately cast samples, cast-on samples, samples cut from a casting) can be used, depending on the mass and wall thickness of the casting. (See Table 3.)

Tensile and impact test pieces shall be machined from the samples after the heat treatment.

8.2 Separately cast samples

8.2.1 Frequency and number of tests

Samples representative of the material shall be produced at a frequency in accordance with the in-process quality assurance procedures adopted by the manufacturer.

In the absence of an in-process quality assurance procedure or any other agreement between the manufacturer and the purchaser, a minimum of one tensile test sample shall be produced to confirm the material grade, at a frequency to be agreed between the manufacturer and the purchaser.

When impact tests are required, samples shall be produced at a frequency to be agreed between the manufacturer and the purchaser.

8.2.2 Samples and test pieces

The samples shall be cast separately in sand moulds at the same time as the castings and under representative manufacturing conditions.

The moulds used to cast the separately cast samples shall have comparable thermal behaviour to the moulding material used to cast the castings.

The samples shall meet the requirements of Figures 1, 2 or 3.

The samples shall be removed from the mould at a temperature similar to that of the castings.

If the spheroidisation treatment is carried out in the mould (in-mould process), the samples may be:

- cast in the same mould with the castings, with a joint running system;
- cast separately, using a similar treatment method in the sample mould as the method used to produce the casting.

The samples shall be given the same heat treatment as the castings which they represent.

The tensile test piece is shown in Figure 5. If applicable, the impact test piece shown in Figure 6 shall be machined from a sample shown in Figures 1 and 2 (hatched part) or from the sample shown in Figure 3.

Unless otherwise agreed, the choice is left to the discretion of the manufacturer.

8.3 Cast-on samples

8.3.1 Frequency and number of tests

Cast-on samples are representative of the castings to which they are attached and also of all other castings, of a similar relevant wall thickness, from the same pouring and heat treatment batch.

Cast-on samples shall be produced in accordance with the in-process quality assurance procedures adopted by the manufacturer.

In the absence of an in-process quality assurance procedure or any other agreement between the manufacturer and the purchaser, a minimum of one tensile test shall be carried out to confirm the material, at a frequency to be agreed between the manufacturer and the purchaser.

When impact tests are required, samples shall be produced at a frequency to be agreed between the manufacturer and the purchaser.

8.3.2 Samples and test pieces

The samples from which the test pieces for tensile and/or impact tests are taken are cast onto the casting, or cast side-by-side with the casting with a joint running system.

For a series of castings poured from the same ladle, one cast-on or cast side-by-side sample shall be produced, at a minimum, for the last mould poured.

The samples shall meet the requirements of either Figures 1, 2, 3 or 4.

When the mass of the casting exceeds 2 000 kg and its thickness exceeds 100 mm, cast-on samples should preferably be used; the dimensions and the location of the cast-on sample shall be agreed between the manufacturer and the purchaser by the time of acceptance of the order.

The sample shall have a general shape as indicated in Figure 4 and the dimensions shown therein.

The location of cast-on samples shall be agreed between the manufacturer and the purchaser by the time of acceptance of the order, taking into account the shape of the casting and the running system, in order to avoid any unfavourable effect on the properties of the adjacent material.

All samples shall be adequately marked to guarantee full traceability to the castings which they represent.

The tensile test piece shown in Figure 5 and, if applicable, the impact test piece shown in Figure 6 shall be machined from a sample shown in Figures 1 and 2 (hatched part) or from the samples shown in Figure 3 or 4. Unless otherwise agreed, the choice is left to the discretion of the manufacturer.

Table 3 — Types of separately cast or cast-on samples and size of tensile test pieces in relation to relevant wall thickness

Relevant wall thickness <i>t</i> mm	Type of cast-on sample				Preferred diameter of tensile test piece ^e <i>D</i> mm
	U-shaped ^a	Y-shaped ^b	Round bar shaped ^c	Sample block ^d	
$t \leq 12,5$	I	I	I, II or III	A	7
$12,5 < t \leq 30$	IIa or IIb	II	I, II or III	B	14
$30 < t \leq 60$	III	III	—	C	14
$60 < t \leq 200$	IV	IV	—	D	14
^a See Figure 1. ^b See Figure 2. ^c See Figure 3. ^d See Figure 4. ^e Other diameters, in accordance with Figure 5, may be agreed between the manufacturer and the purchaser.					

8.4 Samples cut from a casting

8.4.1 General

The manufacturer and the purchaser may agree on the properties required (for information, see Annex E) at stated locations in the heat-treated casting. These properties shall be determined by testing test pieces machined from samples cut from the casting at these stated locations.

The manufacturer and the purchaser shall agree on the diameter of these test pieces.

8.4.2 Other conditions

In the absence of any directions by the purchaser, the manufacturer may choose the locations from which to cut the samples and the diameter of the test pieces.

9 Test methods

9.1 Tensile test

The tensile test shall be carried out in accordance with ISO 6892. The preferred test piece diameter is 14 mm but, either for technical reasons or for test pieces machined from samples cut from the casting, it is permitted to use a test piece of different diameter (see Figure 5). For either of these exceptions, the original gauge length of the test piece shall conform to the equation:

$$L_0 = 5,65 \times \sqrt{S_0} = 5 \times d$$

where

L_0 is the original gauge length;

S_0 is the original cross-section area of the test piece;

d is the diameter of the test piece along the gauge length.

If the above equation for L_0 is not applicable, then an agreement shall be made between the manufacturer and the purchaser on the dimensions of the test piece to be made.

A test piece with a different gauge length may be agreed between the manufacturer and the purchaser. In this case, the minimum elongation values as shown in Table B.1 in Annex B shall be used.

9.2 Impact test, Charpy V

The impact test shall be carried out on three Charpy V-notched impact test pieces (see Figure 6), in accordance with ISO 148 (all parts), using test equipment with an appropriate energy to determine the properties correctly.

9.3 Hardness test

The hardness shall be determined as Brinell hardness in accordance with ISO 6506-1.

Alternative hardness tests and the corresponding required hardness values may also be agreed.

The test shall be carried out on the test pieces at one or several points on the casting(s), after preparation of the testing area in accordance with the agreement between the manufacturer and the purchaser.

If the measurement locations are not the subject of an agreement, they shall be chosen by the manufacturer.

If it is not possible to carry out the hardness test on the casting, then by agreement between the manufacturer and the purchaser, the hardness test may be carried out on a knob cast onto the casting.

Further information on hardness is given in Annex C and Annex D.

10 Retests

10.1 Need for retesting

Retests shall be carried out if a test is not valid.

Retests are permitted to be carried out if a test result does not meet the mechanical property requirement for the specified grade.

10.2 Test validity

A test is not valid if there is:

- a) a faulty mounting of the test piece or defective operation of the test machine;
- b) a defective test piece because of incorrect pouring or incorrect machining;
- c) a fracture of the tensile test piece outside the gauge length;
- d) a casting defect in the test piece, evident after fracture.

In the above cases, a new test piece shall be taken from the same sample or from a duplicate sample cast at the same time and having undergone the same heat treatment.

The results of the retest shall be used.

10.3 Non-conforming test results

If any test gives results which do not conform to the specified requirements, for reasons other than those given in 10.2, the manufacturer shall have the option to conduct retests.

If the manufacturer conducts retests, two retests shall be carried out for each failed test.

If both retests give results that meet the specified requirements, the material shall be deemed to conform to this International Standard.

If one or both retests give results that fail to meet the specified requirements, the material shall be deemed not to conform to this International Standard.

10.4 Heat treatment of samples and castings

In the case of castings which have undergone a heat treatment and for which the test results are not valid or not satisfactory, the manufacturer shall be permitted to re-heat-treat the castings and the representative samples. In this event, the samples shall receive the same number of heat treatments as the castings.

If the results of the tests carried out on the test pieces machined from the re-heat-treated samples are satisfactory, then the re-heat-treated castings shall be regarded as conforming to the specified requirements of this International Standard.

11 Additional information

Annex G and Annex I give, respectively, additional information on mechanical and physical properties, and on machinability of ausferritic spheroidal graphite cast irons.

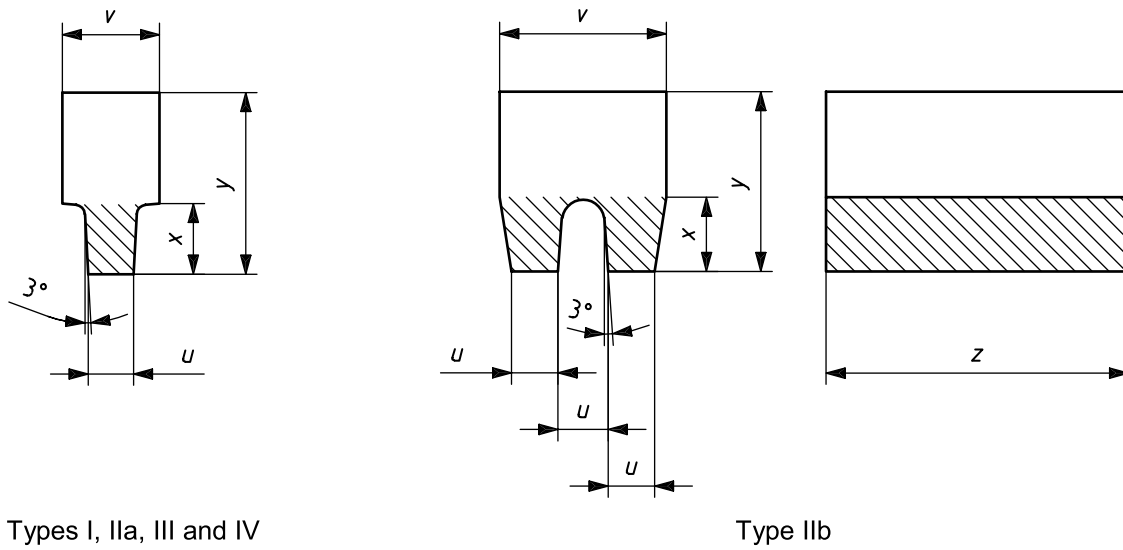

Types I, IIa, III and IV

Type IIb

Dimensions in millimetres

Dimension	Type				
	I	IIa	IIb	III	IV
u	12,5	25	25	50	75
v	40	55	90	90	125
x	30	40	40 to 50	60	65
y^a	80	100	100	150	165
z^b	A function of the test piece length				
^a For information only. ^b z shall be chosen to allow a test piece of dimensions shown in Figure 5 to be machined from the sample.					
The thickness of the sand mould surrounding the samples shall be: <ul style="list-style-type: none"> — 40 mm minimum for types I, IIa, and IIb; — 80 mm minimum for type III. 					
NOTE For the manufacture of thin-walled castings or castings in metal moulds, the tensile properties may, by agreement between the manufacturer and the purchaser, be determined on test pieces taken from samples of thickness u less than 12,5 mm.					

Figure 1 — Separately cast samples — Option 1: I- and U-shaped samples

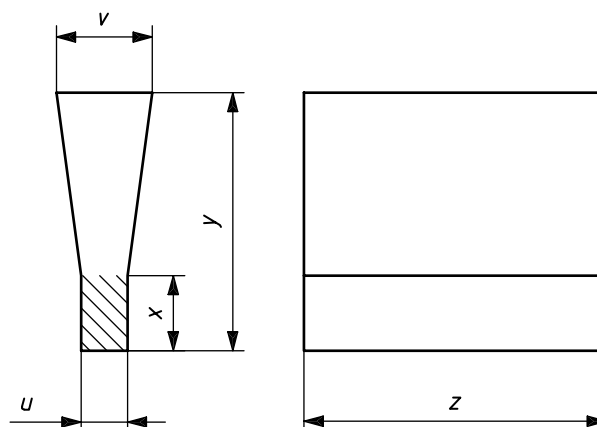

Dimensions in millimetres

Dimension	Type			
	I	II	III	IV
u	12,5	25	50	75
v	40	55	100	125
x	25	40	50	65
y^a	135	140	150	175
z^b	A function of the test piece length			
<p>^a For information only.</p> <p>^b z shall be chosen to allow a test piece of the dimensions shown in Figure 5 to be machined from the sample.</p> <p>The thickness of the sand mould surrounding the samples shall be:</p> <ul style="list-style-type: none"> — 40 mm minimum for types I and II; — 80 mm minimum for type III. <p>NOTE For the manufacture of thin-walled castings or castings in metal moulds, the tensile properties may, by agreement between the manufacturer and the purchaser, be determined on test pieces taken from samples of thickness u less than 12,5 mm.</p>				

Figure 2 — Separately cast samples — Option 2: Y-shaped samples

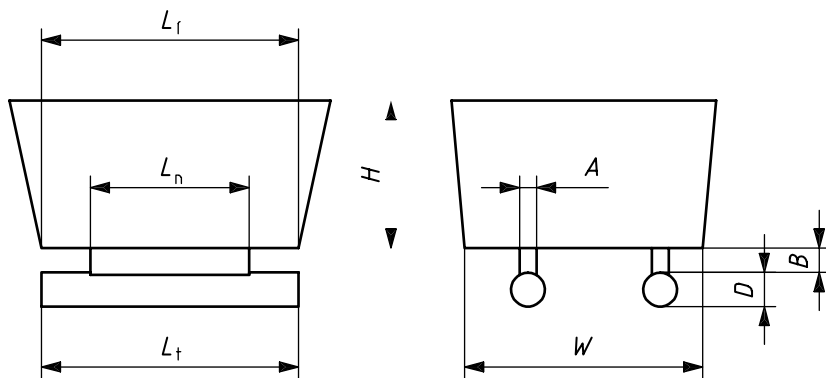

Type I

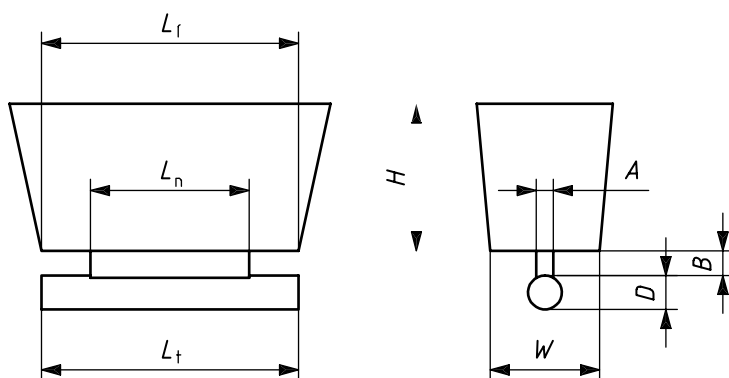

Type II

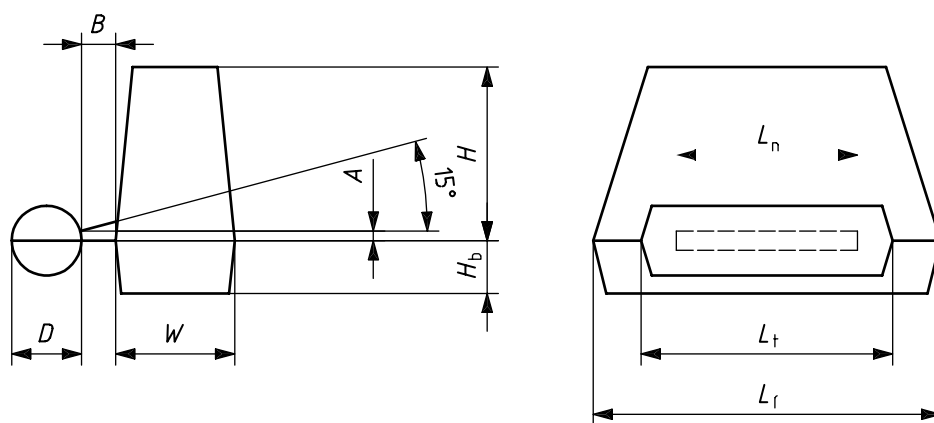

Type III

Sample with feeder

Dimensions in millimetres

Type	A	B	D	H	H_b	L_f	L_n	L_t	W
I	4,5	5,5	25	50	—	$L_t + 20$	$L_t - 50$	See Figure 5	100
II	4,5	5,5	25	50	—	$L_t + 20$	$L_t - 50$		50
III	4,0	5,0	25	50	15	L_t	$L_t - 50$		50

Figure 3 — Separately cast and cast-on samples — Option 3: Round bar-shaped sample for 14 mm tensile test piece

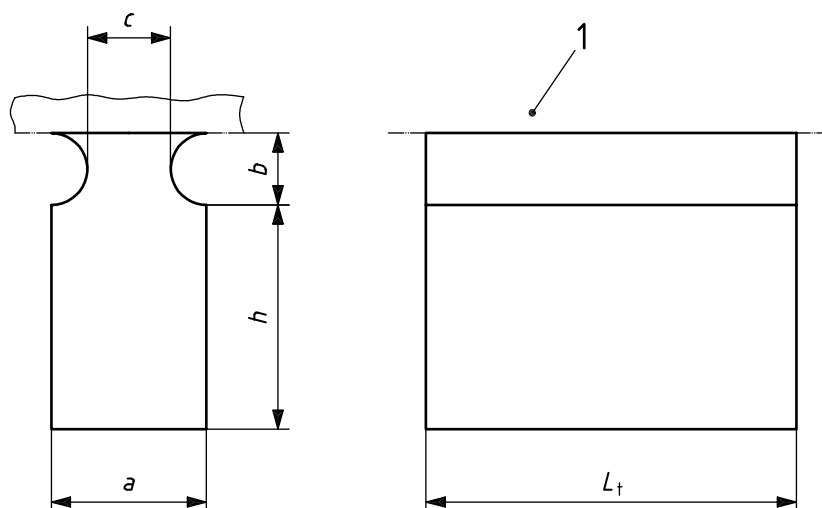
**Key**

1 casting (or running system)

Dimensions in millimetres

Type	Relevant wall thickness of castings t	a	b max.	c min.	h	L_t
A	$t \leq 12,5$	15	11	7,5	20 to 30	^a
B	$12,5 < t \leq 30$	25	19	12,5	30 to 40	^a
C	$30 < t \leq 60$	40	30	20	40 to 65	^a
D	$60 < t \leq 200$	70	52,5	35	65 to 105	^a

^a L_t shall be chosen to allow a test piece of a dimension shown in Figure 5 to be machined from the sample.

NOTE If smaller dimensions are agreed, the following relationships apply:

- $b = 0,75 \times a$
- $c = 0,5 \times a$

Figure 4 — Cast-on samples — Option 4

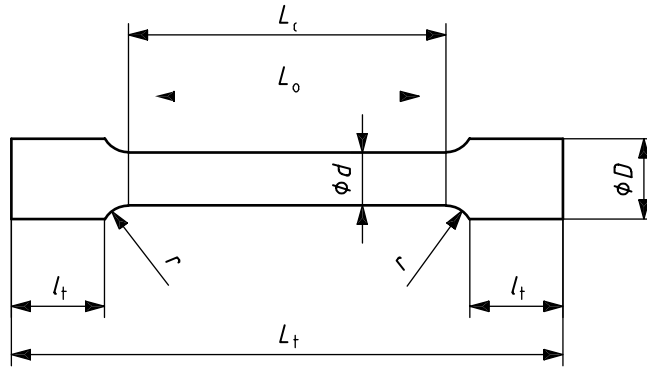

Dimensions in millimetres

d	L_0	L_c min.
5	25	30
7	35	42
10	50	60
14 ^a	70	84
20	100	120

where

- L_0 is the original gauge length, i.e. $L_0 = 5d$;
- d is the diameter of the test piece along the gauge length;
- L_c is the parallel length; $L_c > L_0$ (in principle, $L_c - L_0 > d$);
- L_t is the total length of the test piece, which depends on L_c .

NOTE The method of gripping the ends of the test piece, together with their length l_t , may be agreed between the manufacturer and the purchaser.

^a Preferred dimension.

Figure 5 — Tensile test piece

Dimensions in millimetres

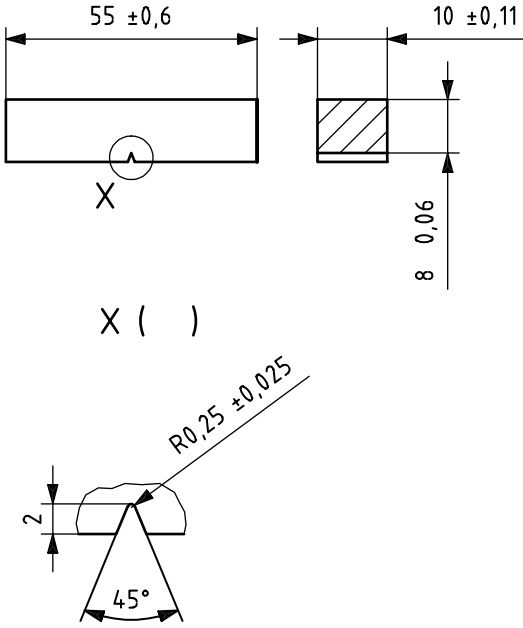

Figure 6 — Charpy V-notched impact test piece

Annex A (normative)

Abrasion-resistant grades of ausferritic spheroidal graphite cast iron

A.1 Scope

This annex defines the grades of abrasion-resistant ausferritic spheroidal graphite cast iron.

It specifies the grades in terms of hardness.

A.2 Requirements

The Brinell hardness for the different grades shall be as specified in Table A.1. Table A.1 also gives other properties for information only.

Table A.1 — Abrasion-resistant ausferritic spheroidal graphite cast irons

Material designation	Brinell hardness		Other properties (for information only)		
	HBW		R_m	$R_{p0,2}$	A
	minimum		N/mm ²	N/mm ²	%
ISO17804/JS/HBW400	400		1 400	1 100	1
ISO17804/JS/HBW450	450		1 600	1 300	—

NOTE 1 The manufacturer and the purchaser may agree on the maximum Brinell hardness.

NOTE 2 1 N/mm² = 1 MPa.

NOTE 3 If the type of sample is to be specified, a "/" is added to the designation, followed by a letter indicating the type of sample:
 — S for a separately cast sample;
 — U for a cast-on sample;
 — C for a casting.

A.3 Sampling

Unless otherwise specified by the purchaser by the time of acceptance of the order, the number and frequency of Brinell hardness tests shall be in accordance with the in-process quality assurance procedures used by the manufacturer.

If it is not possible to carry out the hardness test on the casting, then by agreement between the manufacturer and the purchaser, the hardness test may be carried out on a knob cast onto, and heat treated with, the casting.

A.4 Hardness test

The Brinell hardness test shall be carried out in accordance with ISO 6506-1.

NOTE 1 Hardness determined by one test method is not necessarily comparable to hardness determined by other test methods. Hardness conversion from other test methods can be done by agreement between the manufacturer and the purchaser.

Each Brinell hardness test shall be carried out on a casting at locations agreed between the manufacturer and the purchaser, or on a cast-on test block.

Unless otherwise specified by the purchaser, the dimensions and location of the cast-on block shall be left to the discretion of the manufacturer.

NOTE 2 A cast-on test block can be used when the size of the casting or the number of castings to be tested makes direct testing on the castings impracticable.

If the test is to be carried out on a cast-on block, the latter shall not be removed from the casting until after the heat treatment has been carried out.

When castings are too large or too difficult to be tested in a conventional hardness testing machine or when there is the need for on-line inspection of a large number of castings, a portable hardness-testing device may be used.

When using portable hardness-testing devices, reference shall be made to appropriately calibrated test blocks.

A.5 Retests

Retests shall be permitted and carried out under the same conditions as those specified in Clause 10.

Annex B (normative)

Minimum elongation values for a test piece with original gauge length $L_0 = 4 \times d$

Minimum elongation values are given in Table B.1.

Table B.1 — Mechanical properties measured on test pieces machined from separately cast samples or cast-on samples — Tensile test piece with original gauge length $L_0 = 4 \times d$ [2]

Material designation	Relevant wall thickness of the casting t mm	Tensile strength	0,2 % proof strength	Elongation
		R_m N/mm ² min.	$R_{p0,2}$ N/mm ² min.	$A_{(L_0 = 4 \times d)}$ % min.
ISO 17804/JS/800-10 ISO 17804/JS/800-10RT	$t \leq 30$ $30 < t \leq 60$ $60 < t \leq 100$	800 750 720	500	11 7 6
ISO 17804/JS/900-8	$t \leq 30$ $30 < t \leq 60$ $60 < t \leq 100$	900 850 820	600	9 6 5
ISO 17804/JS/1050-6	$t \leq 30$ $30 < t \leq 60$ $60 < t \leq 100$	1 050 1 000 970	700	7 5 4
ISO 17804/JS/1200-3	$t \leq 30$ $30 < t \leq 60$ $60 < t \leq 100$	1 200 1 170 1 140	850	4 3 2
ISO 17804/JS/1400-1	$t \leq 30$	1 400	1 100	1
	$30 < t \leq 60$ $60 < t \leq 100$	1 170 1 140	To be agreed between the manufacturer and purchaser	

NOTE 1 The properties of castings are not uniform because of the complexity and variation in section thickness.

NOTE 2 With the heat treatment, the specified minimum 0,2 % proof strength values according to Table B.1 can be maintained. However, with increasing casting wall thickness, the tensile strength and elongation values will decrease.

NOTE 3 1 N/mm² = 1 MPa.

NOTE 4 If the type of sample is to be specified, a “/” is added to the designation, followed by a letter indicating the type of sample:

— S for a separately cast sample;

— U for a cast-on sample.

Annex C (informative)

Guidance values for Brinell hardness

Guidance values are given in Table C.1.

Table C.1 — Guidance values for Brinell hardness

Material designation	Brinell hardness range HBW
ISO 17804/JS/800-10	250 to 310
ISO 17804/JS/800-10RT	
ISO 17804/JS/900-8	280 to 340
ISO 17804/JS/1050-6	320 to 380
ISO 17804/JS/1200-3	340 to 420
ISO 17804/JS/1400-1	380 to 480

When necessary or required for machinability, and by agreement between the manufacturer and the purchaser, a narrower range may be adopted at an agreed location on the casting.

A range between 30 and 40 HBW units is commonly acceptable for grades JS/800-10 and JS/800-10RT. Wider ranges may be required as tensile strength and hardness increase.

Annex D (informative)

Procedure for the determination of the hardness range

D.1 General

The following procedure may be used to determine the hardness range for a particular foundry process that is capable of meeting the requirements of a grade specified by tensile properties according to Table 1.

The procedure is most applicable to serial production of castings.

D.1.1 Procedure

D.2.1 Select the required material grade from Table 1.

D.2.2 Select the type of sample to be used according to Table 3.

D.2.3 Use test samples covering the given hardness range for the specified grade shown in Table C.1.

D.2.4 Determine the tensile strength, 0,2 % proof strength, elongation and Brinell hardness for each test piece and for the corresponding castings at the agreed locations. Round the hardness values to the nearest 10 HBW. Conduct as many tests as necessary to obtain the minimum number for each HBW value, as agreed between the manufacturer and the purchaser or to obtain the desired statistical confidence.

D.2.5 Plot the tensile strength, 0,2 % proof strength and elongation versus hardness of castings and/or test pieces in histograms, with HBW as the independent variable.

D.2.6 For each HBW value, adopt the minimum value for each tensile property as the process capability indicator.

D.2.7 Specify the minimum hardness for castings and/or test pieces as the minimum HBW value for which tensile strength and 0,2 % proof strength meet the requirements of the specified grade in Table 1.

D.2.8 Specify the maximum hardness for castings and/or test pieces, a range between 30 and 40 HBW units is commonly acceptable for grades JS/800-10 and JS/800-10RT. Wider ranges may be required as tensile strength and hardness increase.

D.2.9 Using the graph plotted in D.2.5, determine whether the required minimum elongation, as given in Table 1, is met at the maximum hardness specified in D.2.8.

If the required minimum elongation is not met, there are three options:

- maintain this maximum hardness and specify a lower minimum elongation;
- specify a lower maximum hardness and a narrower hardness range;
- specify a lower minimum and maximum hardness. In this case, a lower minimum tensile strength and 0,2 % proof strength shall be specified.

The chosen option shall be agreed between the manufacturer and the purchaser.

D.2.10 If the required minimum elongation is met, a higher minimum elongation for the specified grade may be agreed between the manufacturer and the purchaser.

Annex E (informative)

Guidance values for tensile strength and elongation for test pieces machined from samples cut from a casting [1]

Guidance values are given in Table E.1

Table E.1 — Guidance values for tensile strength and elongation for test pieces machined from samples cut from a casting

Material designation	0,2 % proof strength $R_{p0,2}$ N/mm ² min.	Tensile strength R_m N/mm ² min.			Elongation A % min.		
		Relevant wall thickness, t (mm)					
		$t \leq 30$	$30 < t \leq 60$	$60 < t \leq 100$	$t \leq 30$	$30 < t \leq 60$	$60 < t \leq 100$
ISO 17804/JS/800-10/C	500	790	740	710	8	5	4
ISO 17804/JS/900-8/C	600	880	830	800	7	4	3
ISO 17804/JS/1050-6/C	700	1 020	970	940	5	3	2
ISO 17804/JS/1200-3/C	850	1 170	1 140	1 110	2	1	1
ISO 17804/JS/1400-1/C	1 100	1 360	To be agreed between the manufacturer and the purchaser.				

Annex F (informative)

Unnotched impact test

F.1 Purpose

This annex gives an indirect method to determine conformance to the required microstructure after heat treatment, provided that the required mechanical properties have been verified by other means.

This annex is applicable only when its requirements have been agreed between the manufacturer and the purchaser by the time of acceptance of the order.

F.2 Requirements

The minimum impact-resistance values for the different material grades shall be as specified in Table F.1.

Table F.1 — Unnotched impact-resistance values for ausferritic spheroidal graphite cast iron [3][4]

Material designation	Minimum impact-resistance values at $(23 \pm 5) \text{ }^\circ\text{C}$ J
ISO 17804/JS/800-10	110
ISO 17804/JS/800-10RT	
ISO 17804/JS/900-8	100
ISO 17804/JS/1050-6	80
ISO 17804/JS/1200-3	60
ISO 17804/JS/1400-1	35
ISO 17804/JS/HBW400	25
ISO 17804/JS/HBW450	20
<p>NOTE 1 Values obtained from unnotched test pieces tested at $(23 \pm 5) \text{ }^\circ\text{C}$. The values in this table are the average of the three highest values of four separate tests.</p> <p>NOTE 2 If the type of sample is to be specified, a “/” is added to the designation, followed by a letter indicating the type of sample:</p> <ul style="list-style-type: none"> — S for a separately cast sample; — U for a cast-on sample; — C for a casting. 	

F.3 Sampling

The casting process for the samples shall be agreed between the manufacturer and the purchaser. Impact-resistance requirements apply only after the test material has been austempered. The impact test pieces shall be prepared unnotched with dimensions according to Figure 6 after heat treatment.

F.4 Test method

The impact test shall be carried out on four unnotched test pieces in accordance with ISO 148, using test equipment with an appropriate energy to determine the properties correctly.

The lowest impact energy value shall be discarded, and the average of the three remaining values shall be used.

F.5 Retests

Retests shall be permitted and carried out under the same conditions as those specified in Clause 10.

Annex G (informative)

Additional information on mechanical and physical properties

Table G.1 gives technical data for ausferritic spheroidal graphite cast iron and Table G.2 gives typical properties of ausferritic spheroidal graphite cast irons for gear design.

Table G.1 — Typical properties

Technical data for ausferritic spheroidal graphite cast iron [5]		Material designation ISO 17804/JS/					
		800-10 800-10RT	900-8	1050-6	1200-3	1400-1 HBW400	HBW450
Characteristic	unit	Indicative values for properties ^a					
Compression strength σ_{db}	N/mm ²	1 300	1 450	1 675	1 900	2 200	2 500
0,2 % proof strength	N/mm ²	620	700	840	1 040	1 220	1 350
Shear strength σ_{aB}	N/mm ²	720	800	940	1 080	1 260	1 400
0,2 % proof strength	N/mm ²	350	420	510	590	770	850
Torsional strength σ_{tB}	N/mm ²	720	800	940	1 080	1 260	1 400
0,2 % proof strength	N/mm ²	350	420	510	590	770	850
Fracture toughness K_{IC}	MPa√m	62	60	59	54	50	—
Fatigue limits (Wöhler) (rotating bend) unnotched (diameter 10,6 mm) $N = 2 \times 10^6$ cycles	N/mm ²	375	400	430	450	375	300
Fatigue limits (Wöhler) (rotating bend) notched ^b (diameter 10,6 mm) $N = 2 \times 10^6$ cycles	N/mm ²	225	240	265	280	275	270
Typical values							
Modulus of elasticity E (tension and compression)	kN/mm ²	170	169	168	167	165	165
Poisson's ratio ν	—	0,27	0,27	0,27	0,27	0,27	0,27
Shear modulus	kN/mm ²	65	65	64	63	62	62
Density ρ	g/cm ³	7,1	7,1	7,1	7,0	7,0	7,0
Linear expansion coefficient α from 20 °C to 200 °C [6]	μM/(m·K)	18 ^c to 14					
Thermal conductivity λ at 200 °C	W/(m·K)	23 ^d to 20					
NOTE 1 1 N/mm ² = 1 MPa.							
NOTE 2 Unless otherwise specified, the values given in this table apply to measurements at room temperature.							
^a The minimum values can be obtained on wall thicknesses up to 50 mm. For heavier sections, an agreement between the purchaser and manufacturer is recommended.							
^b Notched after heat treatment, with a circumferential 45° V-notch, having a radius of 0,25 mm.							
^c For the lower strength grades, the linear expansion coefficient α will be higher.							
^d For the lower strength grades, the thermal conductivity λ will be higher.							

Table G.2 — Typical properties of ausferritic spheroidal graphite cast irons for gear design

Technical data for ausferritic spheroidal graphite cast iron		Material designation ISO 17804/JS/			
		800-10 800-10RT	900-8	1050-6	1200-3
Characteristic	Unit	Typical values for properties			
Hertzian pressure fatigue strength $\sigma_{H \text{ lim } 90 \%}$ $N = 10^7$ cycles	N/mm ²	1 050	1 100	1 300	1 350
Tooth-root bending fatigue strength $\sigma_{F \text{ lim } 90 \%}$ $N = 10^7$ cycles	N/mm ²	350	320	300	290

Annex H (informative)

Nodularity (or spheroidal graphite rate)

The nodularity of spheroidal graphite cast iron is defined as the percentage of graphite particles that are spheroidal or nodular in shape (forms VI and V of ISO 945)

The percentage is generally determined at $\times 100$ magnification on a polished cut section of a sample. It may also be determined by image analysis, at higher magnification, or even, after prior calibration, by measuring the ultrasonic velocity across the material.

The level of nodularity depends not only on the manufacturing process (charge material, residual magnesium content, inoculation mode, etc.) but also on the cooling modulus of the section in question. Moreover, some degeneration of the graphite in contact with the mould is occasionally observed.

It is not possible to fix precisely a critical level of nodularity, with respect to the minimum characteristics appearing in this International Standard, even for a specified cooling modulus, because the level varies not only with the measuring method used but also with the grade of cast iron in question (in particular its chemical composition) and, to some extent, the number of graphite particles per unit area.

However, a level of nodularity of 90 %, or more, generally ensures (more than enough for $R_{p0,2}$) the minimum tensile properties appearing in this International Standard. Most of the remaining graphite that is not of forms VI and V is then of form IV.

Annex I (informative)

Machinability of ausferritic spheroidal graphite cast irons

I.1 Introduction

In general, the machinability of a material can be described by four criteria:

- chip form;
- surface quality;
- cutting forces;
- tool wear and tool life.

The following clauses provide a general discussion of the machinability of ausferritic spheroidal graphite cast irons as regards these four criteria. In addition, consideration is given to the influence of chemical composition and heat treatment parameters on machinability.

I.2 Chip form

The chip form that results from machining ausferritic spheroidal graphite cast irons does not differ significantly from the chip obtained when machining other spheroidal graphite cast irons. In general, discontinuous segmented chips are produced which can be handled easily. In certain cases, when negative effective rake angles are present, needle chips can also be formed.

I.3 Surface quality

The surface quality of the machined surface is substantially determined by the embedded graphite nodules. The surface quality that results from machining ausferritic spheroidal graphite cast irons is therefore similar to the surface quality obtained when machining other cast irons with spheroidal graphite. Graphite nodules can break out or smear the machined surface. This means that the best surface quality is obtained with sharp positive cutting edges.

I.4 Cutting forces

Mean cutting forces increase with undeformed chip thickness. Because of the discontinuous segmented chips typical of cast irons, the mean cutting force for cast irons, including ausferritic spheroidal graphite cast irons, increases less rapidly with undeformed chip thickness than is the case for steels of comparable hardness.

In general, the mean cutting forces of cast irons are therefore substantially lower than those of steels of comparable hardness at higher feed rates, and are not substantially higher for ausferritic spheroidal graphite cast irons than for pearlitic grades of spheroidal graphite cast irons. However, the cutting forces for ausferritic spheroidal graphite cast irons contain higher dynamic force factors compared to steels of comparable hardness and to pearlitic grades of spheroidal graphite cast irons.

Cutting force oscillations are relatively independent of the tensile strength of ausferritic spheroidal graphite cast irons and increase with higher feed rates and lower cutting speeds. A short and rigid design of the tool-holder system and rigid clamping of the work piece are important, because tool oscillations can reduce tool life due to a chatter-vibration tendency.

I.5 Tool wear and tool life

Ausferritic spheroidal graphite cast irons have higher hardness and higher ductility (elongation) than pearlitic grades of spheroidal graphite cast irons. Tool wear increases with material hardness, and cutting speed shall be reduced, approximately in proportion to increases in hardness. In addition, wear-resistant cutting-tool materials and coating should be applied. For turning, drilling and milling, wear-resistant tungsten carbides (K-grade) show good performance. Furthermore, higher strength and ductility lead to higher cutting temperatures, which can be counteracted by suitable coatings, for example, titanium aluminium nitride (TiAlN) or aluminium oxide (Al_2O_3). Ceramic tools are applicable in some cases. Tool-life improvements can be attained (for example, when milling and drilling with tungsten carbide tools) by using optimised tool geometries that consider the high specific mechanical load on the cutting edge.

I.6 Other considerations

The quality of ausferritic spheroidal graphite cast-iron microstructures can affect machinability significantly. The following influences shall be considered:

- variations in hardness through the microstructure lead to reductions in tool life;
- tool wear increases as the tensile strength increases, and the applicable cutting speed shall be correspondingly reduced;
- a higher percentage of alloying elements (in particular, of carbide-forming elements such as molybdenum) increases tool wear;
- areas of the casting with insufficiently stabilized austenite have poorer machinability.

Annex J (informative)

Cross-references of similar grades of ausferritic spheroidal graphite cast iron

Table J.1 provides a selection of approximate cross-reference of ISO 17804 grade designations to standard grades from current EN, ASTM, JIS and SAE specifications for ausferritic spheroidal graphite cast iron.

Grades are grouped horizontally by equivalent minimum tensile strength. Specification requirements for 0,2 % proof strength and elongation after fracture may differ between two standard grades of the same minimum tensile strength. Refer to the appropriate standard for complete information.

Table J.1 — Cross-references of similar grades

ISO 17804:2005 ^a	ASTM A897-02	ASTM A897M-02	EN 1564:1997	JIS G5503-1995	SAE J2477 May 2004
—	—	—	—	—	AD750
JS/800-10	—	—	EN-GJS-800-8	—	—
JS/800-10RT	—	—	—	—	—
—	125/80/10	850/550/10	—	—	—
JS/900-8	—	—	—	FCAD 900-8	AD900
—	—	—	EN-GJS-1000-5	FCAD 1000-5	—
JS/1050-6	150/100/7	1050/700/7	—	—	AD1050
JS/1200-3	175-125/4	1200/850/4	EN-GJS-1200-2	FCAD 1200-2	AD1200
JS/1400-1	200/155/1	1400/1100/1	EN-GJS-1400-1	FCAD 1400-1	AD1400
—	230/185/—	1600/1300/—	—	—	AD1600
JS/HBW400	200/155/1	1400/1100/1	EN-GJS-1400-1	FCAD 1400-1	AD1400
JS/HBW450	230/185/—	1600/1300/—	—	—	AD1600

^a The complete ISO grade designation includes the ISO standard number (undated), e.g. ISO 17804/JS/800-10.

Bibliography

- [1] ISO/TC 25/WG 2 No. 15, *Statistical report on mechanical properties for different thicknesses*, February 2002
- [2] ISO/TC 25/WG 2 No. 16, *Evaluation of elongation results for gauge length $5 \times d$ (A5) and $4 \times d$ (A4)*, February 2002
- [3] ASTM A897/A897M, *Specification for Austempered Ductile Iron Castings*
- [4] SAE J2477, *Automotive Austempered Ductile (Nodular) Iron Castings (ADI)*
- [5] GILBERT, G.N.J. *BCIRA Journal*, May 1986, Vol. 34, pp. 203-232 (BCIRA Research Report 1663)
- [6] Applied Process Inc., *Coefficient of Thermal Expansion and Thermal Conductivity for various ASTM Grades of ADI*, 1994
- [7] ISO 6336-5, *Calculation of load capacity of spur and helical gears — Part 5: Strength and quality of materials*
- [8] ISO 1083, *Spheroidal graphite cast irons — Classification*

BSI — British Standards Institution

BSI is the independent national body responsible for preparing British Standards. It presents the UK view on standards in Europe and at the international level. It is incorporated by Royal Charter.

Revisions

British Standards are updated by amendment or revision. Users of British Standards should make sure that they possess the latest amendments or editions.

It is the constant aim of BSI to improve the quality of our products and services. We would be grateful if anyone finding an inaccuracy or ambiguity while using this British Standard would inform the Secretary of the technical committee responsible, the identity of which can be found on the inside front cover. Tel: +44 (0)20 8996 9000. Fax: +44 (0)20 8996 7400.

BSI offers members an individual updating service called PLUS which ensures that subscribers automatically receive the latest editions of standards.

Buying standards

Orders for all BSI, international and foreign standards publications should be addressed to Customer Services. Tel: +44 (0)20 8996 9001. Fax: +44 (0)20 8996 7001. Email: orders@bsi-global.com. Standards are also available from the BSI website at <http://www.bsi-global.com>.

In response to orders for international standards, it is BSI policy to supply the BSI implementation of those that have been published as British Standards, unless otherwise requested.

Information on standards

BSI provides a wide range of information on national, European and international standards through its Library and its Technical Help to Exporters Service. Various BSI electronic information services are also available which give details on all its products and services. Contact the Information Centre. Tel: +44 (0)20 8996 7111. Fax: +44 (0)20 8996 7048. Email: info@bsi-global.com.

Subscribing members of BSI are kept up to date with standards developments and receive substantial discounts on the purchase price of standards. For details of these and other benefits contact Membership Administration. Tel: +44 (0)20 8996 7002. Fax: +44 (0)20 8996 7001. Email: membership@bsi-global.com.

Information regarding online access to British Standards via British Standards Online can be found at <http://www.bsi-global.com/bsonline>.

Further information about BSI is available on the BSI website at <http://www.bsi-global.com>.

Copyright

Copyright subsists in all BSI publications. BSI also holds the copyright, in the UK, of the publications of the international standardization bodies. Except as permitted under the Copyright, Designs and Patents Act 1988 no extract may be reproduced, stored in a retrieval system or transmitted in any form or by any means – electronic, photocopying, recording or otherwise – without prior written permission from BSI.

This does not preclude the free use, in the course of implementing the standard, of necessary details such as symbols, and size, type or grade designations. If these details are to be used for any other purpose than implementation then the prior written permission of BSI must be obtained.

Details and advice can be obtained from the Copyright & Licensing Manager. Tel: +44 (0)20 8996 7070. Fax: +44 (0)20 8996 7553. Email: copyright@bsi-global.com.