



BSI Standards Publication

# Textiles — Bare elastane yarns — Determination of resistance to chlorinated water (swimming-pool water)

**National foreword**

This British Standard is the UK implementation of ISO 17608:2015.

The UK committee draws attention to the fact that it voted against the adoption of ISO 17608 as a British Standard, as it is not relevant to testing within the UK.

The UK participation in its preparation was entrusted to Technical Committee TCI/24, Physical testing of textiles.

A list of organizations represented on this committee can be obtained on request to its secretary.

This publication does not purport to include all the necessary provisions of a contract. Users are responsible for its correct application.

© The British Standards Institution 2015.  
Published by BSI Standards Limited 2015

ISBN 978 0 580 77180 4

ICS 59.080.30

**Compliance with a British Standard cannot confer immunity from legal obligations.**

This British Standard was published under the authority of the Standards Policy and Strategy Committee on 30 November 2015.

**Amendments/corrigenda issued since publication**

Date	Text affected
------	---------------

---

INTERNATIONAL  
STANDARD

**ISO**  
**17608**

First edition  
2015-09-01

---

---

**Textiles — Bare elastane yarns  
— Determination of resistance to  
chlorinated water (swimming-pool  
water)**

*Textiles — Fils d'élasthane nu — Détermination de la résistance à  
l'eau chlorée (eau de piscine)*



Reference number  
ISO 17608:2015(E)

© ISO 2015



## **COPYRIGHT PROTECTED DOCUMENT**

© ISO 2015, Published in Switzerland

All rights reserved. Unless otherwise specified, no part of this publication may be reproduced or utilized otherwise in any form or by any means, electronic or mechanical, including photocopying, or posting on the internet or an intranet, without prior written permission. Permission can be requested from either ISO at the address below or ISO's member body in the country of the requester.

ISO copyright office  
Ch. de Blandonnet 8 • CP 401  
CH-1214 Vernier, Geneva, Switzerland  
Tel. +41 22 749 01 11  
Fax +41 22 749 09 47  
copyright@iso.org  
www.iso.org

# Contents

	Page
Foreword .....	iv
<b>1 Scope .....</b>	<b>1</b>
<b>2 Normative references .....</b>	<b>1</b>
<b>3 Terms and definition .....</b>	<b>1</b>
<b>4 Principle .....</b>	<b>1</b>
<b>5 Apparatus .....</b>	<b>2</b>
<b>6 Reagents .....</b>	<b>3</b>
<b>7 Conditioning and testing atmosphere .....</b>	<b>4</b>
<b>8 Preparing test specimens .....</b>	<b>4</b>
<b>9 Testing procedure .....</b>	<b>4</b>
<b>10 Results .....</b>	<b>6</b>
<b>11 Test report .....</b>	<b>6</b>
<b>Bibliography .....</b>	<b>7</b>

## Foreword

ISO (the International Organization for Standardization) is a worldwide federation of national standards bodies (ISO member bodies). The work of preparing International Standards is normally carried out through ISO technical committees. Each member body interested in a subject for which a technical committee has been established has the right to be represented on that committee. International organizations, governmental and non-governmental, in liaison with ISO, also take part in the work. ISO collaborates closely with the International Electrotechnical Commission (IEC) on all matters of electrotechnical standardization.

The procedures used to develop this document and those intended for its further maintenance are described in the ISO/IEC Directives, Part 1. In particular the different approval criteria needed for the different types of ISO documents should be noted. This document was drafted in accordance with the editorial rules of the ISO/IEC Directives, Part 2 (see [www.iso.org/directives](http://www.iso.org/directives)).

Attention is drawn to the possibility that some of the elements of this document may be the subject of patent rights. ISO shall not be held responsible for identifying any or all such patent rights. Details of any patent rights identified during the development of the document will be in the Introduction and/or on the ISO list of patent declarations received (see [www.iso.org/patents](http://www.iso.org/patents)).

Any trade name used in this document is information given for the convenience of users and does not constitute an endorsement.

For an explanation on the meaning of ISO specific terms and expressions related to conformity assessment, as well as information about ISO's adherence to the WTO principles in the Technical Barriers to Trade (TBT) see the following URL: [Foreword - Supplementary information](#)

The committee responsible for this document is ISO/TC 38, *Textiles*, Subcommittee SC 23, *Fibres and yarns*.

# Textiles — Bare elastane yarns — Determination of resistance to chlorinated water (swimming-pool water)

## 1 Scope

This International Standard specifies a method to determine the resistance of bare elastane yarns to chlorinated aqueous environments, such as swimming pools, through testing of the breaking force retention.

Different alternative test conditions are specified. Three different concentrations and two different exposure hours are considered.

This International Standard is applicable to bare elastane yarns only. Result achieved from yarns cannot be used to predict the fabric performance.

## 2 Normative references

The following documents, in whole or in part, are normatively referenced in this document and are indispensable for its application. For dated references, only the edition cited applies. For undated references, the latest edition of the referenced document (including any amendments) applies.

ISO 139, *Textiles — Standard atmospheres for conditioning and testing*

ISO 3696, *Water for analytical laboratory use — Specification and test methods*

## 3 Terms and definition

For the purposes of this document, the following terms and definitions apply.

### 3.1

#### **elastane yarn**

fibre composed of at least 85 % by mass of a segmented polyurethane and which, if stretched to three times its unstretched length, rapidly reverts substantially to the unstretched length when the tension is removed

### 3.2

#### **breaking force retention**

capability of a specimen to retain breaking force after a specified treatment whereby the breaking force of the treated specimen is expressed as a percentage of the initial breaking force

## 4 Principle

Bare elastane yarn is subjected to a “chlorinated-water exposure test”. The physical properties are affected by active chlorine in the solution.

The breaking force retention is the parameter used to determine the chlorine-resistant performance.

## 5 Apparatus

**5.1 Suitable mechanical device**, consisting of a water bath containing a rotatable shaft which supports, radially, stainless steel containers of a diameter of  $(75 \pm 5)$  mm and a height of  $(125 \pm 10)$  mm in  $(550 \pm 50)$  ml capacity, with covers to be sealed.

The bottom of each container is  $(45 \pm 10)$  mm from the centre of the shaft. The shaft/container assembly is rotated at a frequency of  $(40 \pm 2)$  r/min.

The temperature of the water bath is thermostatically controlled to maintain the prescribed temperature  $\pm 2$  °C.

Other mechanical devices may be used for the test provided that equivalent results are obtained.

**5.2 CRE (constant-rate-of-extension) machine**, which meets the following requirements.

- a) The gauge length is set to be  $(50 \pm 0,5)$  mm and constant rates of extension to be  $(500 \pm 10)$  mm per min.
- b) The error of the indicated or recorded maximum force, at any point in the range in which the machine is used, shall not exceed 1 %.

The error of the indicated or recorded jaw separation shall not exceed 0,5 mm.

- c) The jaws shall be capable of holding the test specimen without allowing it to slip.

It is designed so that the jaws do not cut or otherwise weaken the test specimen.

- d) The machine shall be provided with the means for indicating or recording the force within gauge length.
- e) The machine is capable of applying a pre-tension as prescribed by the method.

**5.3 Winding frame**, designed to wind elastane yarn with pre-tension (see [Figure 1](#)).

Dimensions in millimetres

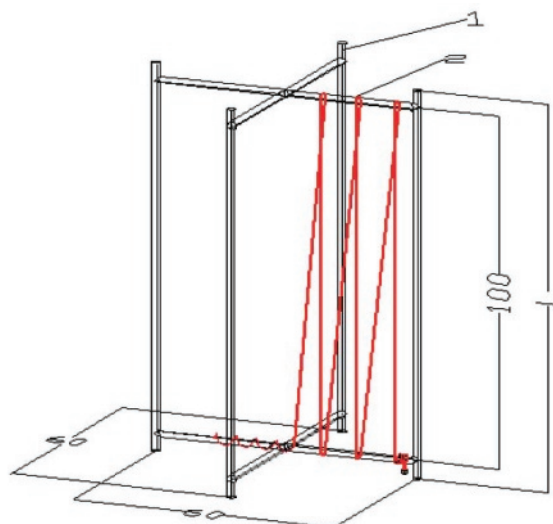

**Figure 1 — Winding frame**



## Key

- 1 winding frame
- 2 specimen
- L height of the frame, subjected to height of the containers (5.1), as to avoid shaking while rotated

**5.4 pH-meter**, having an accuracy of 0,02 units.

## 6 Reagents

**6.1 Deionized water**, Grade 3 quality as specified in ISO 3696.

**6.2** Use only reagents of recognized analytical grade.

**6.3 Sodium hypochlorite**, (NaClO), **aqueous solution**, having the following composition:

- Active chlorine: 40 g/l to 160 g/l.
- Sodium chloride (NaCl): 120 g/l to 170 g/l.
- Sodium hydroxide (NaOH): 20 g/l maximum.
- Sodium carbonate (Na<sub>2</sub>CO<sub>3</sub>): 20 g/l maximum.
- Iron (Fe): 0,01 g/l maximum.

**6.4 Potassium dihydrogenphosphate** (KH<sub>2</sub>PO<sub>4</sub>).

**6.5 Disodium hydrogenphosphate dihydrate** (Na<sub>2</sub>HPO<sub>4</sub>·2H<sub>2</sub>O), or **disodium hydrogenphosphate dodecahydrate** (Na<sub>2</sub>HPO<sub>4</sub>·12H<sub>2</sub>O).

**6.6 Sodium hypochlorite**, (NaClO), **aqueous solution**, containing 100 mg of active chlorine per litre, at pH = 7,50 ± 0,05.

Prepare solutions as follows, using deionized water (6.1).

- Solution 1: dilute 20,0 ml sodium hypochlorite solution (6.3) to 1 l.
- Solution 2: 14,35 g KH<sub>2</sub>PO<sub>4</sub> (6.4) per litre.
- Solution 3: 20,05 g Na<sub>2</sub>HPO<sub>4</sub>·2H<sub>2</sub>O (6.5) per litre, or 40,35 g Na<sub>2</sub>HPO<sub>4</sub>·12H<sub>2</sub>O (6.5) per litre.

To 25,0 ml of Solution 1, add excess of potassium iodide (KI) and hydrochloric acid (HCl), and titrate the liberated iodine with a sodium thiosulfate solution,  $c(\text{Na}_2\text{S}_2\text{O}_3) = 0,1 \text{ mol/l}$ , using starch solution as indicator.

Let the volume of sodium thiosulfate solution required be  $V$  ml.

For each litre of working solution at pH 7,50 ± 0,05, use:

- 705,0/ $V$  ml of Solution 1;
- 100,0 ml of Solution 2;
- 500,0 ml of Solution 3.

Dilute to 1 l, with water.

Before use, check the pH of the solution with a pH-meter (5.4).

If necessary, adjust the pH using either sodium hydroxide,  $c(\text{NaOH}) = 0,1 \text{ mol/l}$ , or acetic acid,  $c(\text{CH}_3\text{COOH}) = 0,1 \text{ mol/l}$ .

All sodium hypochlorite solutions should be prepared just prior to use.

**6.7 Sodium hypochlorite, (NaClO), aqueous solution**, containing 50 mg of active chlorine per litre, at  $\text{pH} = 7,50 \pm 0,05$ .

Follow the same procedure as in 6.6, except that, for each litre of working solution at  $\text{pH} 7,50 \pm 0,05$ , use:

705,0/2V ml of Solution 1.

All sodium hypochlorite solutions should be prepared just prior to use.

**6.8 Sodium hypochlorite, (NaClO), aqueous solution**, containing 20 mg of active chlorine per litre, at  $\text{pH} = 7,50 \pm 0,05$ .

Follow the same procedure as in 6.6, except that, for each litre of working solution at  $\text{pH} 7,50 \pm 0,05$ , use:

705,0/5V ml of Solution 1.

All sodium hypochlorite solutions should be prepared just prior to use.

## 7 Conditioning and testing atmosphere

The standard atmosphere for conditioning and testing shall comply with ISO 139.

## 8 Preparing test specimens

**8.1** Prepare 2 samples for each package and number from 1 to 2 in sequence.

Specimens from number 1 will be tested breaking force 'before exposure', while those from number 2 will be tested 'after exposure'.

**8.2** Discard yarn on the outer layer of a package (about 1 g) and cut yarn to a length of 1,5 m as the first sample.

Discard more yarn, about 3 m to 5 m, before cutting the next sample from the same package.

Carefully unwind the yarn using the smallest amount of tension as possible, so as to prevent any over-tensioning.

## 9 Testing procedure

**9.1** Fix one end of the yarn on the cross part of the winding frame, to avoid any slipping. Wind sample number 2 (8.1) on the frame (see [Figure 1](#)), with the pre-tension related to nominal linear density as recommended in [Table 1](#). Tie another end of the yarn on the frame and ensure that it does not slip. Try to prevent the parts from touching each other.

**Table 1 — Pre-tension options list**

Nominal linear density	Pre-tension
≤ 25 dtex	0,020 cN ± 0,000 2 cN
> 25 dtex to approximately 35 dtex	0,030 cN ± 0,000 3 cN
> 35 dtex to approximately 50 dtex	0,040 cN ± 0,000 4 cN
> 50 dtex to approximately 90 dtex	0,070 cN ± 0,000 7 cN
> 90 dtex to approximately 120 dtex	0,105 cN ± 0,001 0 cN
> 120 dtex to approximately 160 dtex	0,140 cN ± 0,001 4 cN
> 160 dtex to approximately 250 dtex	0,210 cN ± 0,002 1 cN
> 250 dtex to approximately 350 dtex	0,300 cN ± 0,003 0 cN
> 350 dtex	Calculated as (0,001 0 ± 0,000 01) cN/dtex

**9.2** Treat each sample in a separate container in the mechanical device (5.1). Immerse the frame with the sample into the sodium hypochlorite solution (6.6, 6.7, or 6.8), ensuring that the solution filled the container and the sample is thoroughly wetted. Close and agitate the container at (27 ± 2) °C for 24 h or 72 h.

**9.3** Remove the frame with the sample from the container. Rinse with deionized water (6.1) three times and air-dry at room temperature for at least 15 min.

**9.4** Cut sample number 1 (8.1) into several smaller parts in length of 10 cm with a minimum of 5 parts from each sample. Hereafter, these smaller parts are referred to as “specimens”.

Repeat the same procedure to cut sample number 2, which were “after exposure” (see 9.3), discarding those parts bent around frames.

In all, there are a minimum of 5 specimens from the same sample (8.1).

**9.5** Condition the specimens in a standard atmosphere (see Clause 7), in a tension-free state for over 2 h.

**9.6** Choose an appropriate measurement range on the CRE machine (5.2), such that the indicated or recorded maximum breaking force is between 10 % to 90 % of the full range.

**9.7** Place one end of the specimen in the middle of the upper-clamp and the other end in the middle of the lower-clamp, at a pre-tension specified in 9.1.

Ensure the specimen lies along the axis of CRE machine and tighten the clamps.

Set the traversing clamp in motion and extend the specimen to rupture, recording the breaking force.

**9.8** If the specimen has slipped or broken near the jaw, discard it and replace it with another one.

**9.9** Repeat procedure 9.7 and test 5 specimens cut from same numbered sample.

**9.10** Test 5 specimens from number 1.

Calculate the mean value of the 5 individual breaking forces. Report this mean value as the breaking force “before exposure” ( $F_1$ ).

**9.11** Test 5 specimens from number 2.

Calculate the mean value of the 5 individual breaking forces. Report this mean value as the breaking force “after exposure” ( $F_2$ ).

## 10 Results

The result is expressed as breaking force retention, calculated according to Formula (1).

$$\lambda = \frac{F_2}{F_1} \times 100\% \quad (1)$$

where

$\lambda$  is the breaking force retention;

$F_1$  is the breaking force “before exposure”, expressed in cN;

$F_2$  is the breaking force “after exposure”, expressed in cN.

The result is to be rounded to the nearest 0,1%.

## 11 Test report

The test report shall include the following information:

- a) a reference to this International Standard, i.e. ISO 17608;
- b) all details necessary for the identification of the sample tested (including method of preparation, if applicable);
- c) test conditions (concentration of active chlorine, time of exposure and pre-tension);
- d) test results (breaking force “before exposure”, breaking force “after exposure” and breaking force retention);
- e) any deviation, by agreement or otherwise, from the procedure specified;
- f) any unusual phenomena observed.

## Bibliography

- [1] ISO 105-E03, *Textiles — Tests for colour fastness — Part E03: Colour fastness to chlorinated water (swimming-pool water)*
- [2] ISO 5079, *Textile fibres — Determination of breaking force and elongation at break of individual fibres*





# British Standards Institution (BSI)

BSI is the national body responsible for preparing British Standards and other standards-related publications, information and services.

BSI is incorporated by Royal Charter. British Standards and other standardization products are published by BSI Standards Limited.

## About us

We bring together business, industry, government, consumers, innovators and others to shape their combined experience and expertise into standards-based solutions.

The knowledge embodied in our standards has been carefully assembled in a dependable format and refined through our open consultation process. Organizations of all sizes and across all sectors choose standards to help them achieve their goals.

## Information on standards

We can provide you with the knowledge that your organization needs to succeed. Find out more about British Standards by visiting our website at [bsigroup.com/standards](http://bsigroup.com/standards) or contacting our Customer Services team or Knowledge Centre.

## Buying standards

You can buy and download PDF versions of BSI publications, including British and adopted European and international standards, through our website at [bsigroup.com/shop](http://bsigroup.com/shop), where hard copies can also be purchased.

If you need international and foreign standards from other Standards Development Organizations, hard copies can be ordered from our Customer Services team.

## Subscriptions

Our range of subscription services are designed to make using standards easier for you. For further information on our subscription products go to [bsigroup.com/subscriptions](http://bsigroup.com/subscriptions).

With **British Standards Online (BSOL)** you'll have instant access to over 55,000 British and adopted European and international standards from your desktop. It's available 24/7 and is refreshed daily so you'll always be up to date.

You can keep in touch with standards developments and receive substantial discounts on the purchase price of standards, both in single copy and subscription format, by becoming a **BSI Subscribing Member**.

**PLUS** is an updating service exclusive to BSI Subscribing Members. You will automatically receive the latest hard copy of your standards when they're revised or replaced.

To find out more about becoming a BSI Subscribing Member and the benefits of membership, please visit [bsigroup.com/shop](http://bsigroup.com/shop).

With a **Multi-User Network Licence (MUNL)** you are able to host standards publications on your intranet. Licences can cover as few or as many users as you wish. With updates supplied as soon as they're available, you can be sure your documentation is current. For further information, email [bsmusales@bsigroup.com](mailto:bsmusales@bsigroup.com).

## BSI Group Headquarters

389 Chiswick High Road London W4 4AL UK

## Revisions

Our British Standards and other publications are updated by amendment or revision.

We continually improve the quality of our products and services to benefit your business. If you find an inaccuracy or ambiguity within a British Standard or other BSI publication please inform the Knowledge Centre.

## Copyright

All the data, software and documentation set out in all British Standards and other BSI publications are the property of and copyrighted by BSI, or some person or entity that owns copyright in the information used (such as the international standardization bodies) and has formally licensed such information to BSI for commercial publication and use. Except as permitted under the Copyright, Designs and Patents Act 1988 no extract may be reproduced, stored in a retrieval system or transmitted in any form or by any means – electronic, photocopying, recording or otherwise – without prior written permission from BSI. Details and advice can be obtained from the Copyright & Licensing Department.

## Useful Contacts:

### Customer Services

**Tel:** +44 845 086 9001

**Email (orders):** [orders@bsigroup.com](mailto:orders@bsigroup.com)

**Email (enquiries):** [cservices@bsigroup.com](mailto:cservices@bsigroup.com)

### Subscriptions

**Tel:** +44 845 086 9001

**Email:** [subscriptions@bsigroup.com](mailto:subscriptions@bsigroup.com)

### Knowledge Centre

**Tel:** +44 20 8996 7004

**Email:** [knowledgecentre@bsigroup.com](mailto:knowledgecentre@bsigroup.com)

### Copyright & Licensing

**Tel:** +44 20 8996 7070

**Email:** [copyright@bsigroup.com](mailto:copyright@bsigroup.com)



...making excellence a habit.™