

BS ISO 17497-2:2012



BSI Standards Publication

Acoustics — Sound-scattering properties of surfaces

Part 2: Measurement of the directional diffusion coefficient in a free field

bsi.

...making excellence a habit.™

National foreword

This British Standard is the UK implementation of ISO 17497-2:2012.

The UK participation in its preparation was entrusted to Technical Committee EH/1/6, Building acoustics.

A list of organizations represented on this committee can be obtained on request to its secretary.

This publication does not purport to include all the necessary provisions of a contract. Users are responsible for its correct application.

© The British Standards Institution 2012. Published by BSI Standards Limited 2012

ISBN 978 0 580 71826 7

ICS 91.120.20

Compliance with a British Standard cannot confer immunity from legal obligations.

This British Standard was published under the authority of the Standards Policy and Strategy Committee on 31 May 2012.

Amendments issued since publication

Date	Text affected
------	---------------

**Acoustics — Sound-scattering properties
of surfaces —**

Part 2:

**Measurement of the directional diffusion
coefficient in a free field**

Acoustique — Propriétés de dispersion du son par les surfaces —

Partie 2: Mesurage du coefficient de diffusion directionnel en champ libre





COPYRIGHT PROTECTED DOCUMENT

© ISO 2012

All rights reserved. Unless otherwise specified, no part of this publication may be reproduced or utilized in any form or by any means, electronic or mechanical, including photocopying and microfilm, without permission in writing from either ISO at the address below or ISO's member body in the country of the requester.

ISO copyright office
Case postale 56 • CH-1211 Geneva 20
Tel. + 41 22 749 01 11
Fax + 41 22 749 09 47
E-mail copyright@iso.org
Web www.iso.org

Published in Switzerland

Contents

Page

Foreword	iv
Introduction	v
1 Scope	1
2 Normative references	1
3 Terms and definitions	1
4 Measurement principle	3
5 Frequency range	4
6 Test arrangement	4
6.1 Measurement environment	4
6.2 Measurement field	5
6.3 Test specimen	6
7 Test procedure	7
7.1 Test signals	7
7.2 Source and receiving equipment	7
7.3 Measurements	7
7.4 Polar response processing	8
8 Expression of results	11
8.1 Directional diffusion coefficient	11
8.2 Normalized directional diffusion coefficient	12
8.3 Calculation of area factors	12
8.4 Random incidence diffusion coefficient	12
8.5 Presentation of results	13
9 Test report	13
Annex A (normative) Qualification of a measurement space	14
Bibliography	15

Foreword

ISO (the International Organization for Standardization) is a worldwide federation of national standards bodies (ISO member bodies). The work of preparing International Standards is normally carried out through ISO technical committees. Each member body interested in a subject for which a technical committee has been established has the right to be represented on that committee. International organizations, governmental and non-governmental, in liaison with ISO, also take part in the work. ISO collaborates closely with the International Electrotechnical Commission (IEC) on all matters of electrotechnical standardization.

International Standards are drafted in accordance with the rules given in the ISO/IEC Directives, Part 2.

The main task of technical committees is to prepare International Standards. Draft International Standards adopted by the technical committees are circulated to the member bodies for voting. Publication as an International Standard requires approval by at least 75 % of the member bodies casting a vote.

Attention is drawn to the possibility that some of the elements of this document may be the subject of patent rights. ISO shall not be held responsible for identifying any or all such patent rights.

ISO 17497-2 was prepared by Technical Committee ISO/TC 43, *Acoustics*, Subcommittee SC 2, *Building acoustics*.

ISO 17497 consists of the following parts, under the general title *Acoustics—Sound-scattering properties of surfaces*:

- *Part 1: Measurement of the random-incidence scattering coefficient in a reverberation room*
- *Part 2: Measurement of the directional diffusion coefficient in a free field*

Introduction

The degree of acoustic scattering from surfaces is very important in all aspects of room acoustics, e.g. in concert halls, sound studios, industrial halls and reverberation chambers. The degree of scattering and absorption in a room are important factors related to the acoustic quality of the room. This part of ISO 17497 addresses the measurement and characterization of scattering surfaces.

The scattering coefficient is introduced in ISO 17487-1. In this part of ISO 17487, a measurement method for the directional diffusion coefficient is introduced. The diffusion coefficient is different from, but related to, the random incidence scattering coefficient. While the scattering coefficient is a rough measure that describes the degree of scattered sound, the diffusion coefficient describes the directional uniformity of the scattering, i.e. the quality of the diffusing surface. Consequently, there is a need for both concepts, and they have different applications.

The work has been coordinated with the working group of the Audio Engineering Society, AES SC-04-02 for the Characterization of Acoustical Materials.

Acoustics — Sound-scattering properties of surfaces —

Part 2:

Measurement of the directional diffusion coefficient in a free field

1 Scope

This part of ISO 17497 specifies a method of measuring the directional diffusion coefficient of surfaces.

The diffusion coefficient characterizes the sound reflected from a surface in terms of the uniformity of the reflected polar distribution. The diffusion coefficient is a measure of quality designed to inform producers and users of surfaces that, either deliberately or accidentally, diffuse sound. It can also inform developers and users of geometric room acoustic models. The diffusion coefficient is not suitable for direct use as an input to current diffusion algorithms in geometric room acoustic models.

This part of ISO 17497 details a free-field characterization method.

2 Normative references

The following documents, in whole or in part, are normatively referenced in this document and are indispensable for its application. For dated references, only the edition cited applies. For undated references, the latest edition of the referenced document (including any amendments) applies.

ISO 266, *Acoustics — Preferred frequencies*

IEC 61260, *Electroacoustics — Octave-band and fractional-octave-band filters*

3 Terms and definitions

For the purposes of this document, the following terms and definitions apply.

3.1

sound ray

line following one possible direction of sound propagation from a source point

3.2

specular reflection

reflection that obeys Snell's law, i.e. the angle of reflection is equal to the angle of incidence

Note 1 to entry Specular reflection can be obtained approximately from a plane, rigid surface with dimensions much larger than the wavelength of the incident sound.

3.3

specular zone

area contained by imaginary lines that are constructed from the image source, which is created about the plane of a specified reference flat surface via the edges of that surface to the receiver arc or hemisphere

Note 1 to entry The reference flat surface is a plane and rigid surface, with the same projected shape or footprint as the test surface.

Note 2 to entry The position at which an imaginary line from the image source to a receiver crosses the diffuser is the specular reflection point (see Figure 1).

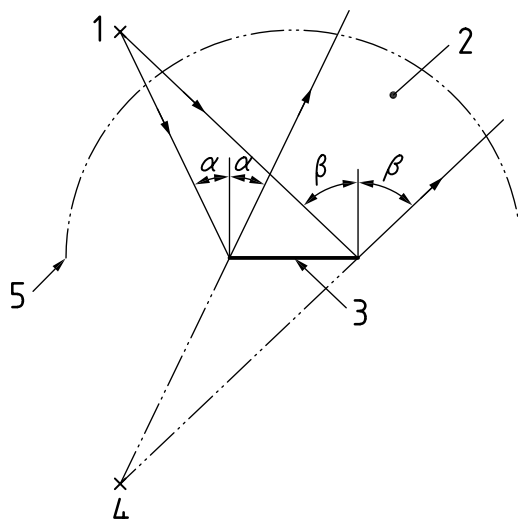

Key

- 1 source
- 2 specular zone
- 3 diffuser
- 4 image source
- 5 receiver arc

Figure 1 — Representation of specular zone

**3.4
far field**

region in which the reflected sound pressure level from the test surface decays by 6 dB per doubling of distance

Note 1 to entry In the near field, the shape of the angular field distribution is dependent on the distance from the diffuser.

**3.5
single plane diffuser**

surface that displays distinct anisotropic behaviour, as can be the case for a cylinder or a one-dimensional Schroeder diffuser

Note 1 to entry For these surfaces, the diffusion is measured in the plane of maximum diffusion.

**3.6
multiple-plane diffuser**

surface that is expected to display more approximately isotropic behaviour, as can be the case for a hemisphere or a two-dimensional Schroeder diffuser

Note 1 to entry For these surfaces, hemispherical evaluation is appropriate, yielding a single diffusion coefficient. Alternatively, measurements can be done in two orthogonal planes.

**3.7
semicircular polar response**

sound pressure level created by energy scattered from the surface as a function of angle measured about the reference normal, generated under free-field or pseudo-free-field conditions, in a specified plane, on a semicircle centred at the reference point, at an appropriate radial distance

Note 1 to entry The reference normal is an outward-pointing vector perpendicular to the front face of a reference flat surface. The reference point is the geometric centre of gravity of the reference flat surface

3.8**hemispherical polar response**

sound pressure level scattered from the surface as a function of spherical coordinates measured about the reference normal, generated under free-field or pseudo-free-field conditions, on a hemisphere centred at the reference point

3.9**directional diffusion coefficient** $d_{\theta,\phi}$

measure of the uniformity of diffusion produced by a surface for one source position

Note 1 to entry The value of $d_{\theta,\phi}$ is bounded between 0 and 1. When complete diffusion is achieved by the surface, the diffusion coefficient is 1. However, real diffusers rarely have diffusion coefficients higher than 0.7. If only one receiver receives non-zero scattered sound pressure, the diffusion coefficient is 0. The subscript θ is used to indicate the angle of incidence relative to the reference normal of the surface. The ϕ indicates the azimuth angle.

3.10**random incidence diffusion coefficient** d

measure of the uniformity of diffusion for a representative sample of sources over a complete semicircle for a single plane diffuser, or a complete hemisphere for a hemispherical diffuser

Note 1 to entry A mean or a weighting of the directional diffusion coefficients for the difference source positions is used to calculate the diffusion coefficient, as specified in 8.4. A guideline to achieve a representative sample of sources is given in 6.2.2. The lack of a subscript for d indicates random incidence.

3.11**normalized directional diffusion coefficient** $d_{\theta,\phi,n}$

directional diffusion coefficient of the test specimen normalized to that of the reference flat surface

3.12**normalized diffusion coefficient** d_n

random incidence diffusion coefficient determined from the normalized directional diffusion coefficient

3.13**physical scale ratio** $1:N$

ratio of linear dimension in a physical scale model to the same linear dimension in full scale

Note 1 to entry The wavelength of the sound used in a scale model for acoustic measurements obeys the same physical scale ratio. Therefore, if the speed of sound is the same in the model as in full scale, the frequencies used for the model measurements are a factor of N times higher than in full scale.

4 Measurement principle

The diffusion coefficient quantifies how the energy reflected from a surface is spatially distributed. This spatial distribution is described by polar responses of the reflected sound pressure level. A source is used to irradiate the test surface, and microphones at radial positions in front of the surface are used to measure the sound. The reflected sound is extracted from the microphone signals using the process outlined in Clause 7. The diffusion coefficient is then calculated from the reflected sound pressure levels using the equations shown in Clause 8. To remove finite-panel effects, which cause the diffusion coefficient to decrease as the frequency increases, a normalized diffusion coefficient is calculated.

The microphone positions should map out a semicircle or hemisphere, for a single plane or hemispherical measurement, respectively. Single-plane diffusers can be measured using a two-dimensional goniometer, either using a boundary plane measurement (see Figure 3) or in an anechoic chamber. A multi-plane diffuser can be characterized by making two single plane measurements in orthogonal planes in a two-dimensional goniometer — this is the quickest and easiest approach. Alternatively, a hemispherical measurement can be done using a three-dimensional goniometer (see Figure 2).

5 Frequency range

The measurements shall be performed in one-third-octave bands with centre frequencies covering the frequency range from 100 Hz to 5 000 Hz, in accordance with IEC 61260 and ISO 266. This refers to full-scale measurements. If a physical scale factor of $1:N$ is used, the centre frequencies should cover the frequency range from $N \times 100$ Hz to $N \times 5\,000$ Hz.

If the scale model is filled with a gas in which the speed of sound is different from that in atmospheric air, the measurement frequencies shall be chosen in such a way that the wavelength obeys the physical scale ratio $1:N$.

High frequencies may be omitted from the measurements if the attenuation in the air is too high.

6 Test arrangement

6.1 Measurement environment

Annex A describes the measurement environments that shall be used. A qualified anechoic chamber can be used. An implementation of such a set-up is illustrated in Figure 2. Alternatively, a large non-anechoic space can be used to simulate a reflection-free environment if certain techniques described in Annex A are used.

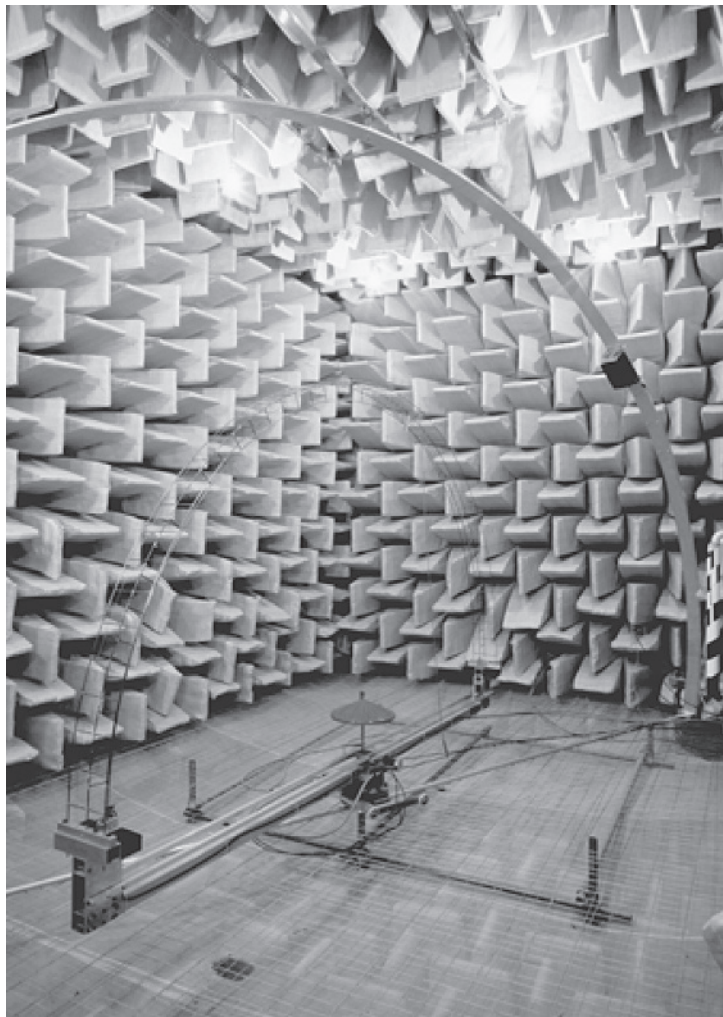

Figure 2 — Three-dimensional measurement goniometer

Boundary measurements may also be carried out to remove the necessity for a space to be anechoic in one plane provided conditions in Annex A are satisfied. An implementation of such a set-up is illustrated in Figure 3.

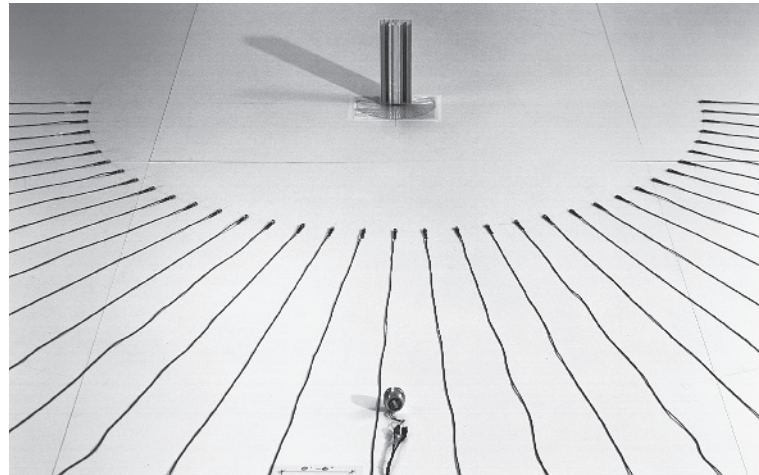

Figure 3 — Two-dimensional boundary measurement technique

Scale models may be used to evaluate the diffusion from test surfaces. If the speed of sound is the same in the model as in full scale, then the frequencies used for the model measurements shall be a factor of N higher than in full scale. For scale models, the absorption properties shall be the same for both the full-scale surface at full-scale frequencies and the test surface sample at the equivalent model-scale frequency. When considering absorption from samples, losses due to viscous boundary layer effects shall be included. This inclusion can limit the useable model scales.

6.2 Measurement field

6.2.1 Near-field versus far-field measurements

Diffusers may be applied in situations where some or all sources and receivers are in the near field. In such cases, measurements to determine the diffusion coefficient should take place both at application-realistic near-field positions and in the far field. The tests in the far field monitor the amount of diffusion achieved, measurements in the near field shall be used to check for near-field aberrations, particularly focusing.

An exception to the preceding rule occurs if the diffuser is to be applied only for far field sources and receivers, in which case, diffusion coefficient measurements may be undertaken only in the far field.

When comparing test surfaces, the same geometry shall be used in each case to avoid errors. Full geometry information, source locations, receiver positions, and test surface dimensions and construction shall be quoted in reports.

6.2.2 Far-field measurements

Approximate far-field conditions can be achieved if at least 80 % of the receiver positions are outside the specular zone, see Figure 4. The source to reference-point distance should be 10 m and the receiver's semi-circle or hemisphere should have a radius of 5 m.

Measurements shall be made with a maximum receiver angular resolution of 5° (i.e. $\Delta\theta \leq 5^\circ$ and $\Delta\phi \leq 5^\circ$). This may be achieved using either a discrete fixed position system or a continuous moving system.

To obtain a random-incidence diffusion coefficient of a hemispherical diffuser, source positions covering a hemisphere shall be selected with the azimuth and elevation angles as given in Table 1. For the definition of angles, see Figure 7. For a survey measurement, the four positions with numbers 1, 8, 10, and 12 in Table 1 should be used.

When the two-dimensional boundary measurement technique is used, the preferred source positions are at the angles 0° , $\pm 30^\circ$, and $\pm 60^\circ$ relative to the reference normal.

Table 1 — Source positions for hemispherical measurements

Position number	Elevation θ	Azimuth ϕ
1	0	-
2	30	0
3	30	60
4	30	120
5	30	180
6	30	240
7	30	300
8	60	0
9	60	60
10	60	120
11	60	180
12	60	240
13	60	300

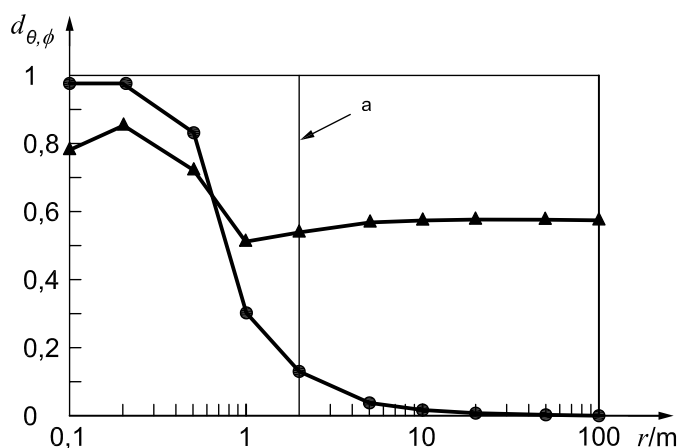

Key

$d_{\theta, \phi}$ diffusion coefficient
 r radius of receiver arc

a Here, 80 % of receivers are outside the specular zone.

Figure 4 — Variation of diffusion coefficient with receiver distance

6.2.3 Near-field measurements

Near-field receiver and source locations should be a representative sample from the anticipated application positions. Where these are not known, source and receivers should be chosen to ensure that any focusing effects are measured in typical application-realistic positions.

6.3 Test specimen

6.3.1 Single-plane diffusers

For a test sample to be a single plane diffuser, it shall have a surface structure and acoustic impedance that is constant in one direction, x . A single plane diffusion coefficient can then be measured in a plane, usually

orthogonal to x , to give a figure of merit for the plane of maximum diffusion. Initially, testing for uniformity of the surface structure and impedance should be done by visual inspection.

6.3.2 Multiple-plane diffusers

When uniformity cannot be determined by visual inspection, then measurements of diffusion coefficients on multiple planes should be made. Measurements in two orthogonal planes should normally be sufficient to determine whether the surface is anisotropic or isotropic, and consequently whether a hemispherical measurement or a series of single plane measurements best represent the diffusion from the surface.

6.3.3 Selection of test sample

When choosing whether part or all of a surface is to be used as a test sample, the application of the surface in real rooms and of the geometric limitations set forth in this part of ISO 17497 shall be considered, particularly the requirement to keep 80 % of the receivers outside the specular zone. Where possible, the test surface should be chosen so that the entire structure to be applied in the real room is tested. This choice ensures that the diffraction due to surface roughness and edge effects are properly characterized.

For large samples, it may be impossible to test the entire structure. In such cases, the following scheme may be applied for reducing the test surface size.

For a periodic sample test surface, at least three complete repeat sequences and if possible more periods should be included, so that the lobing effects of repetition can approach reality as closely as possible.

For aperiodic surfaces or random surfaces, representative samples of the surface roughness should be tested. These samples should be large enough to ensure that surface effects rather than edge effects are more prominent in the scattering.

The geometry suggested for the measurement in this part of ISO 17497 is applicable for frequencies up to and including the 5 kHz one-third-octave band full scale.

7 Test procedure

7.1 Test signals

Measurements of the magnitude polar response are obtained using transfer-function techniques (e.g. impulse response measurements, FFT, TDS, swept sine, or MLS in accordance with ISO 18233^[7]).

7.2 Source and receiving equipment

A loudspeaker that illuminates the entire diffuser as if it were an omnidirectional source should be chosen. The loudspeaker shall create a sound pressure distribution equivalent to what would be expected from a true omnidirectional source, to within ± 2 dB in magnitude and $\pm 20^\circ$ in phase, over the reference flat surface.

Microphones should have the same sensitivity to all conceivable reflection paths from the diffuser directly to the microphone, to within ± 1 dB in magnitude and $\pm 10^\circ$ in phase.

7.3 Measurements

For each source and receiver pair the following measurements shall be made:

- the impulse response with the test surface present, $h_1(t)$;
- the impulse response with no test surface present, $h_2(t)$;
- if more than one microphone or source is used, the impulse response without the test surface present and with the source centred on the reference point, facing the receiver position, $h_3(t)$.

The transfer function may be obtained as an equivalent measure to the impulse response.

7.4 Polar response processing

7.4.1 General

The principle is to measure the impulse response in such a way that the reflection from the test sample can be isolated from other reflections. The data reduction process is represented in Figure 5 and Figure 6.

The influence of background reflections shall be removed by subtracting $h_2(t)$ from $h_1(t)$.

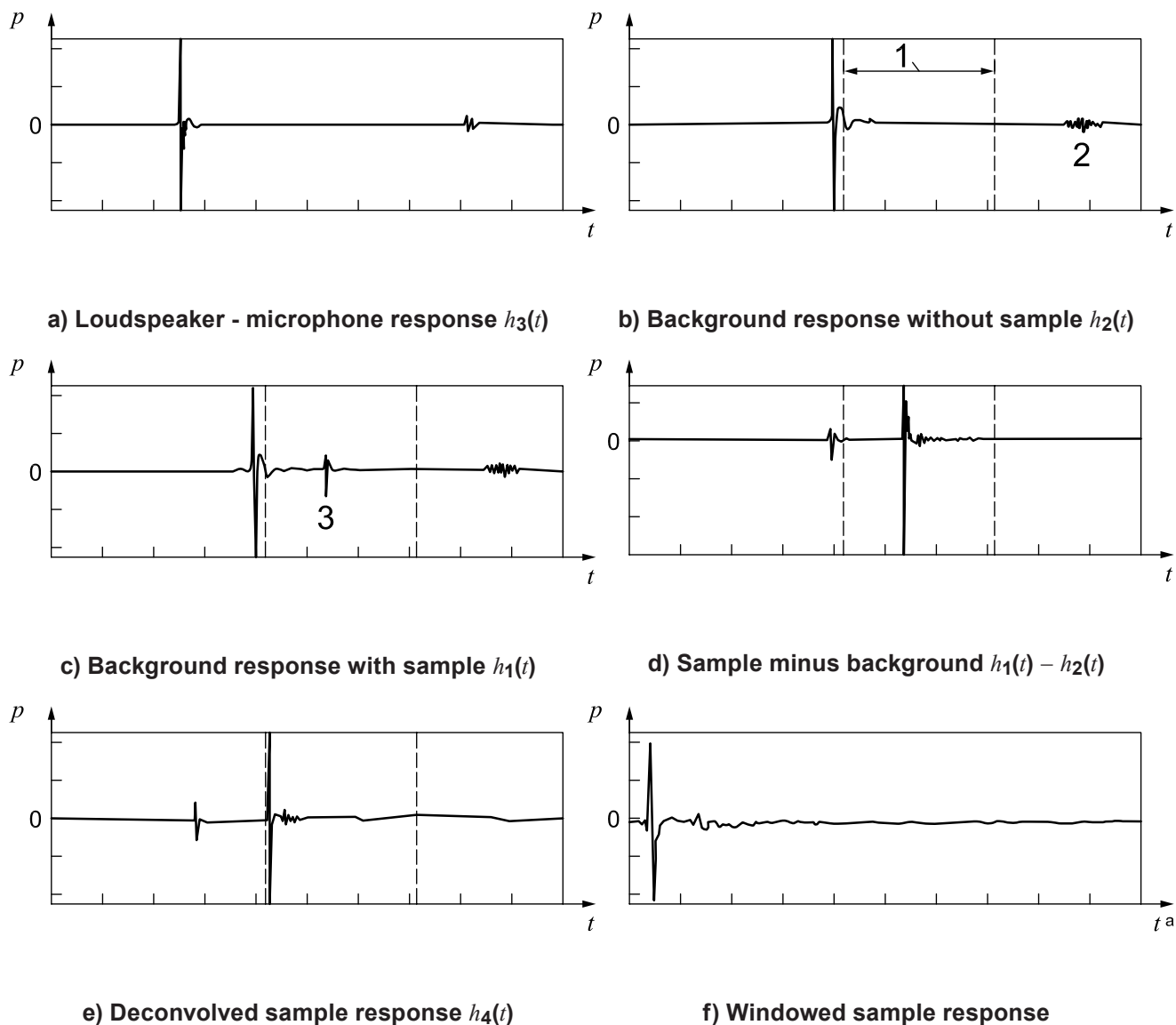

Key

p	pressure	1	time window
t	time	2	interference
t^a	time (expanded axis)	3	sample

Figure 5 — Data reduction process

NOTE All graphs are relative sound pressure as function of time.

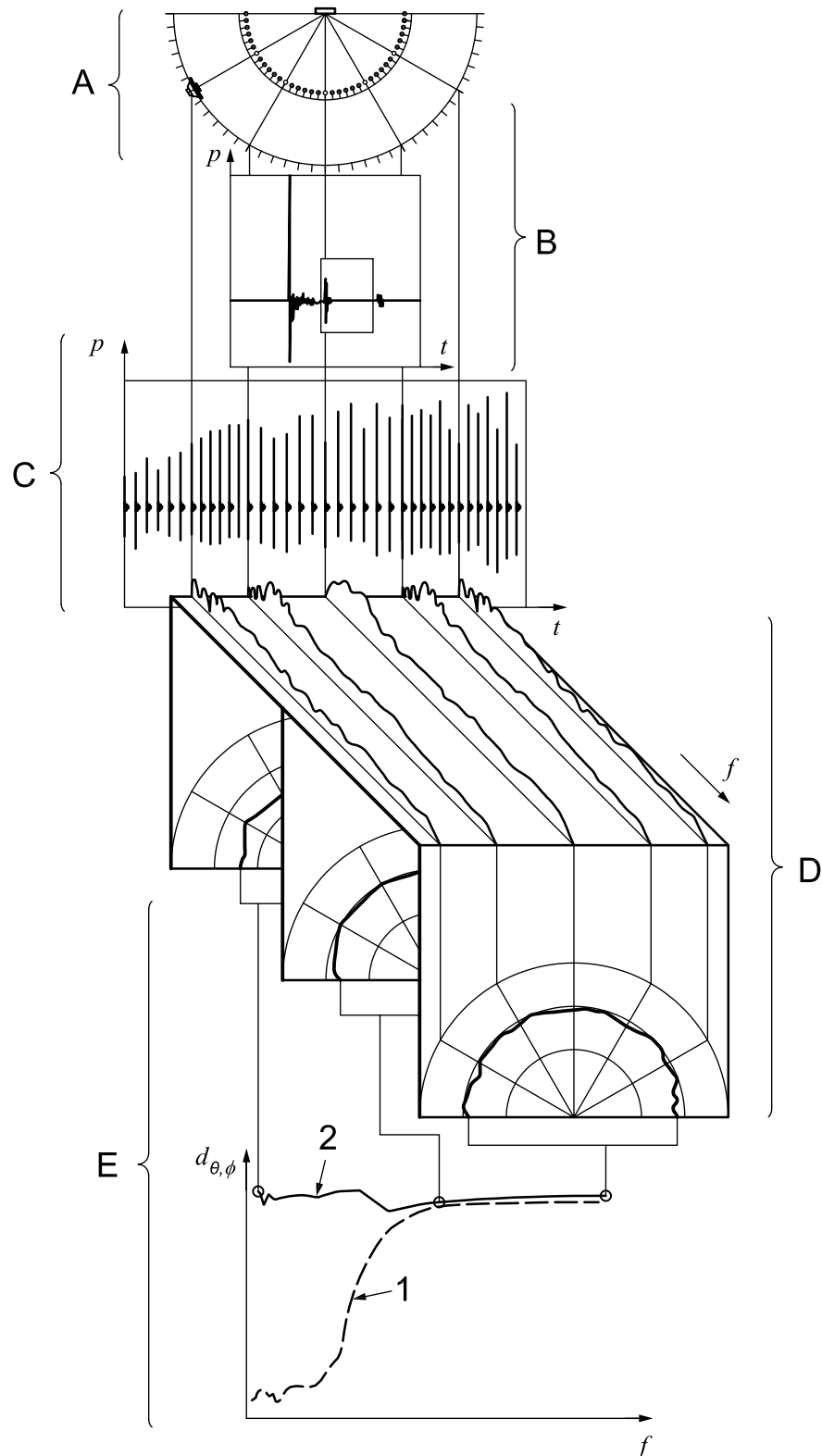

Key

$d_{\theta, \phi}$	diffusion coefficient	p	pressure	1	normalized
f	frequency	t	time	2	without normalization

Figure 6 — Process to extract the diffusion coefficient from the impulse response: A — measurement geometry; B — time response, h_1 ; C — concatenated time responses; D — one-third-octave polar responses; E — diffusion coefficient as a function of frequency

7.4.2 Loudspeaker-microphone response

For systems using more than one microphone and loudspeaker, the loudspeaker and microphone response is deconvoluted from the subtracted impulse response as given in Formula (1):

$$h_4(t) = F^{-1} \left\{ \frac{F[h_1(t) - h_2(t)]}{F[h_3(t)]} \right\} \quad (1)$$

where

F is a forward Fourier transform;

F^{-1} an inverse Fourier transform.

7.4.3 Windowing

A rectangular window is applied to the impulse response. The window has unity gain where the diffuser reflections are present, and is zero elsewhere. The window removes residual reflections clearly separated from the diffuser reflections in time. The size of the window is determined by considering the shortest and longest time for reflections from the surface. The shortest time can be calculated from simple geometric consideration. For the longest possible reflection path, it is necessary to consider more than just the first order reflections from the surface to ensure that the full diffuser response is obtained. Visual inspection of the impulse response is a recommended method for determining the window location and size.

Within the windowed section of the impulse response, a signal-to-noise ratio of at least 40 dB should be obtained for the reference flat surface. In such a case, noise not only refers to random measurement error, but also to biases due to unwanted reflections from objects other than the surface being measured. This signal-to-noise ratio can be obtained by calculating Formula (2):

$$10 \lg \left\{ \frac{\int_T [h_1(t) - h_2(t)]^2 dt}{\int_T h_2^2(t) dt} \right\} \text{ dB} \quad (2)$$

where T is the length of the rectangular window.

The signal-to-noise ratio should be tested in each of the one-third-octave bands being measured.

NOTE A high pass filter to reduce low frequencies below the measurement bandwidth can facilitate the visual inspection of the impulse response for determining window location and size.

The deconvolution of Formula (1) causes the location of the direct sound in h_4 to be different from h_3 and this needs to be considered when windowing.

7.4.4 Fourier transformation

The windowed impulse response shall then undergo Fourier transformation and the one-third-octave level, L' , in decibels, is obtained in each frequency band of interest. These frequencies should conform to ISO 266. The one-third-octave levels are the powers in each frequency band obtained by a numerical integration assuming infinite roll-off filters at the edge of the band. After the Fourier transformation, at least three one-spectral points shall lie in each one-third-octave band of interest. Zero padding shall not be used to satisfy this criterion.

NOTE For the numerical integration, filters conforming to IEC 61260 are not used because they are too exacting for use in this method.

7.4.5 Corrections

If a range of source and receiver distances r_1 and r_2 are used, then the measured levels should be corrected to allow for spherical or cylindrical spreading. The combined distance r is given by Formula (3):

$$r = \frac{2 r_1 r_2}{r_1 + r_2} \text{ m} \quad (3)$$

Normalizing to standard distances of $r_1 = 10$ m and $r_2 = 5$ m, the i th correct measured levels are given by Formula (4):

$$L_i = L'_i + \varepsilon 10 \lg \left(\frac{r}{6,67} \right) \text{ dB} \quad (4)$$

where

ε is equal to 1 for cylindrical spreading;

ε is equal to 2 for spherical spreading.

However, where possible, measurements should be made over an arc to remove distance variation. This is because the distance correction in Formula (4) is approximate, as test surfaces do not reflect sound to form exact spherical or cylindrical waves.

8 Expression of results

8.1 Directional diffusion coefficient

For a fixed source position, in each one-third-octave band, the directional diffusion coefficient may be calculated from the set of sound pressure levels L_i in decibels, from the n receivers by using Formula (5):

$$d_\theta = \frac{\left(\sum_{i=1}^n 10^{L_i/10} \right)^2 - \sum_{i=1}^n \left(10^{L_i/10} \right)^2}{(n-1) \sum_{i=1}^n \left(10^{L_i/10} \right)^2} \quad (5)$$

Formula (5) is only valid when each receiver position samples the same measurement area. This sampling is automatically achieved for single plane measurements on an arc with an even angular spacing between receivers.

NOTE The fact that receiver positions at $\pm 90^\circ$ actually sample half the area of the other receivers can be ignored, since a correction makes no significant difference to the diffusion coefficient.

For some measurements, the area sampled by a receiver varies with receiver position. In that case, Formula (6) should be used:

$$d_\theta = \frac{\left(\sum_{i=1}^n 10^{L_i/10} N_i \right)^2 - \sum_{i=1}^n N_i \left(10^{L_i/10} \right)^2}{\left(\sum_{i=1}^n N_i - 1 \right) \sum_{i=1}^n N_i \left(10^{L_i/10} \right)^2} \quad (6)$$

where N_i is proportional to the area sampled by receiver point i and should be calculated from Formula (8).

This arises for hemispherical measurements using an even angular spacing between receiver positions in azimuth, ϕ , and elevation, θ , see Figure 7.

8.2 Normalized directional diffusion coefficient

The normalized directional diffusion coefficient is calculated from the Formula (7)

$$d_{\theta,n} = \frac{d_{\theta} - d_{\theta,r}}{1 - d_{\theta,r}} \quad (7)$$

where $d_{\theta,r}$ is the directional diffusion coefficient for the reference flat surface.

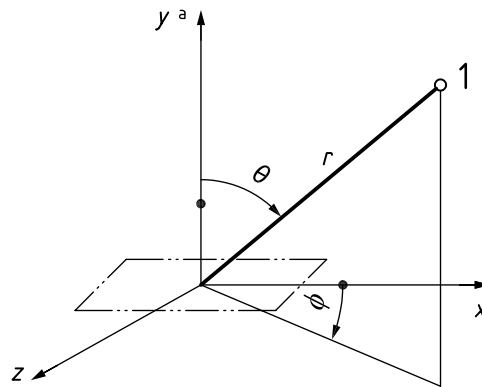

Key

- 1 Receiver
- ^a Reference normal

Figure 7 — Coordinate system

8.3 Calculation of area factors

For the hemispherical case, the factors N_i may be calculated as follows:

$$A_i = \frac{4\pi}{\Delta\phi} \sin^2\left(\frac{\Delta\theta}{4}\right) \quad \theta = 0^\circ$$

$$A_i = 2 \sin(\theta) \sin\left(\frac{\Delta\theta}{2}\right) \quad \theta \neq 0^\circ, |\theta| \neq 90^\circ$$

$$A_i = \sin\left(\frac{\Delta\theta}{2}\right) \quad |\theta| = 90^\circ$$

where $\Delta\phi$ and $\Delta\theta$ are the angular spacings, each usually 5° , in azimuth and elevation between adjacent receivers. Formula (8) assumes a single measurement at $\theta = 0^\circ$.

The area factor N_i assigned to receiver point i is calculated from Formula (8):

$$N_i = \frac{A_i}{A_{\min}} \quad (8)$$

where A_{\min} is the smallest value of A_i for $i = 1 \dots n$.

8.4 Random incidence diffusion coefficient

The normalized or non-normalized directional diffusion coefficients are averaged over all sources to obtain the normalized or non-normalized random incidence diffusion coefficient. When measured with all the source positions given in 6.2.2, then the coefficient may be termed a random-incidence diffusion coefficient.

For hemispherical measurements, all source positions are averaged with equal weightings.

For two-dimensional measurements, the averaging is performed with different weightings; the source position at 0° is given a weight of 1, and the four source positions at other angles are each given a weight of 3.

8.5 Presentation of results

The corrected one-third-octave polar responses of L_i for the normal incidence source position shall be tabulated at the angular resolution of the measurement for the frequency range as specified in Clause 5. For hemispherical measurements, only the polar response at an incidence angle of 0° azimuth shall be tabulated. The polar responses should be rounded to the nearest 0,1 dB.

The polar responses should be presented in a graphical representation on a semi-circular polar plot. A separate graph shall be given for each one-third octave band and each source position, with both the reference flat surface and diffuser measurement shown. The points of measurement for each surface should be connected by straight lines. The radial axis shall be in decibels.

The diffusion coefficient and normalized diffusion coefficient shall be presented in a table for each one-third-octave band. The coefficients should be rounded to two decimal places.

In a graphical representation, the points of the measurement should be connected by straight lines, the abscissa giving the frequency on a logarithmic scale and the ordinate showing the results from 0 to 1 on a linear scale. The abscissa should be in equivalent full-scale values with a statement of the scale ratio 1: N . The ratio of the ordinate distance from 0 to 1, to the abscissa distance of five octaves should be 2:3.

9 Test report

The test report shall include at least the following information:

- a) reference to this part of ISO 17497 (i.e. ISO 17497-2:2012);
- b) name of the organization that performed the test;
- c) date of test;
- d) description of the test specimen, its surface area, the structural depth, with sectional drawings and a photo;
- e) scale of the test sample relative to the full size product;
- f) coordinates of the source and receiver positions;
- g) whether the measurements were made in a single plane, multiple planes, or over a hemisphere, and a statement of the planes used;
- h) details of the measurement technique used to obtain the polar responses;
- i) results, reported in accordance with 8.5.

Annex A (normative)

Qualification of a measurement space

A.1 Space criteria

For the frequency and distance range in which measurements are to be undertaken, the measured sound pressure level from the measurement loudspeaker alone should not deviate by more than 1 dB from the sound pressure level described by the free-field inverse distance law (i.e. sound pressure from a point source is inversely proportional to distance).

The measurement space shall exhibit a 40 dB signal-to-noise ratio within the rectangular window as described in 7.4.3.

A.2 Environments

An anechoic chamber where the sound pressure reflection coefficient of the walls is no more than 0,05, which is equivalent to having an absorption coefficient greater than 0,997 5, may be used.

A large non-anechoic space may be used to simulate a reflection-free environment by putting a time window on a measured impulse response before applying a FFT or by using TDS measurements to exclude the reflections.

A.3 Placement

Microphones, loudspeakers and test surface may be placed on a fully reflective surface to enable the measurements to be made in a hemi-anechoic chamber or a pseudo-hemi-anechoic environment. The surface should have a sound pressure reflection coefficient of at least 0,99. The fully reflective surface shall be sufficiently large to ensure that edge diffraction from this surface is at least 40 dB below the signal within the rectangular window.

Sources and receivers shall be sufficiently close to the reflective surface to ensure that all frequencies being measured do not suffer from destructive interference due to grazing reflections.

NOTE 1 This condition can be achieved by ensuring that measurement elements are no further than $\lambda/4$, where λ is wavelength, from the fully reflective surface.

NOTE 2 For full scale measurement, time variance needs to be considered, and it may be advisable to measure h_1 , h_2 and h_3 for each source-receiver pair one after the other, rather than measure h_1 for all sources and receivers, followed by all h_2 , followed by all h_3 .

NOTE 3 Window length affects the resolution of low frequency measurement; however, this is normally below the frequency range within which most surfaces cause significant diffusion.

Bibliography

- [1] COX, T.J., LAM, Y.W. Evaluation of methods for predicting the scattering from simple rigid panels. *Appl. Acoust.* 1993, **40**, pp. 123-140
- [2] COX, T.J., LAM, Y.W. Prediction and evaluation of the scattering from quadratic residue diffusors. *J. Acoust. Soc. Am.* 1994, **95**, pp. 297-305
- [3] D'ANTONIO, P., KONNERT, J. The directional scattering coefficient: Experimental determination. *J. Audio Eng. Soc.* 1992, **40**, pp. 997-1017
- [4] D'ANTONIO, P., KONNERT, J.H., KOVITZ P. The disc project: Experimental measurement of the directional scattering properties of architectural acoustic surfaces. *Wallace Clement Sabine centennial symposium*, Cambridge, MA. New York, NY: Acoustical Society of America, 1994, pp. 141-144
- [5] HARGREAVES, T.J., COX, T.J., LAM, Y.W., D'ANTONIO, P. Surface diffusion coefficients for room acoustics: free field measures. *J. Acoust. Soc. Am.* 2000, **108**, pp. 1710-1720
- [6] COX, T.J., DALENBACK, B.I., D'ANTONIO, P., EMBRECHTS, J.J., JEON, J.Y., MOMMERTZ, E., VORLANDER, M. A tutorial on scattering and diffusion coefficients for room acoustic surfaces. *Acta Acust. Acust.* 2006, **92**, pp. 1-15
- [7] ISO 18233, *Acoustics — Application of new measurement methods in building and room acoustics*

British Standards Institution (BSI)

BSI is the national body responsible for preparing British Standards and other standards-related publications, information and services.

BSI is incorporated by Royal Charter. British Standards and other standardization products are published by BSI Standards Limited.

About us

We bring together business, industry, government, consumers, innovators and others to shape their combined experience and expertise into standards-based solutions.

The knowledge embodied in our standards has been carefully assembled in a dependable format and refined through our open consultation process. Organizations of all sizes and across all sectors choose standards to help them achieve their goals.

Information on standards

We can provide you with the knowledge that your organization needs to succeed. Find out more about British Standards by visiting our website at bsigroup.com/standards or contacting our Customer Services team or Knowledge Centre.

Buying standards

You can buy and download PDF versions of BSI publications, including British and adopted European and international standards, through our website at bsigroup.com/shop, where hard copies can also be purchased.

If you need international and foreign standards from other Standards Development Organizations, hard copies can be ordered from our Customer Services team.

Subscriptions

Our range of subscription services are designed to make using standards easier for you. For further information on our subscription products go to bsigroup.com/subscriptions.

With **British Standards Online (BSOL)** you'll have instant access to over 55,000 British and adopted European and international standards from your desktop. It's available 24/7 and is refreshed daily so you'll always be up to date.

You can keep in touch with standards developments and receive substantial discounts on the purchase price of standards, both in single copy and subscription format, by becoming a **BSI Subscribing Member**.

PLUS is an updating service exclusive to BSI Subscribing Members. You will automatically receive the latest hard copy of your standards when they're revised or replaced.

To find out more about becoming a BSI Subscribing Member and the benefits of membership, please visit bsigroup.com/shop.

With a **Multi-User Network Licence (MUNL)** you are able to host standards publications on your intranet. Licences can cover as few or as many users as you wish. With updates supplied as soon as they're available, you can be sure your documentation is current. For further information, email bsmusales@bsigroup.com.

BSI Group Headquarters

389 Chiswick High Road London W4 4AL UK

Revisions

Our British Standards and other publications are updated by amendment or revision.

We continually improve the quality of our products and services to benefit your business. If you find an inaccuracy or ambiguity within a British Standard or other BSI publication please inform the Knowledge Centre.

Copyright

All the data, software and documentation set out in all British Standards and other BSI publications are the property of and copyrighted by BSI, or some person or entity that owns copyright in the information used (such as the international standardization bodies) and has formally licensed such information to BSI for commercial publication and use. Except as permitted under the Copyright, Designs and Patents Act 1988 no extract may be reproduced, stored in a retrieval system or transmitted in any form or by any means – electronic, photocopying, recording or otherwise – without prior written permission from BSI. Details and advice can be obtained from the Copyright & Licensing Department.

Useful Contacts:

Customer Services

Tel: +44 845 086 9001

Email (orders): orders@bsigroup.com

Email (enquiries): cservices@bsigroup.com

Subscriptions

Tel: +44 845 086 9001

Email: subscriptions@bsigroup.com

Knowledge Centre

Tel: +44 20 8996 7004

Email: knowledgecentre@bsigroup.com

Copyright & Licensing

Tel: +44 20 8996 7070

Email: copyright@bsigroup.com



...making excellence a habit.™