

BS ISO 17458-1:2013



BSI Standards Publication

Road vehicles — FlexRay communications system

Part 1: General information and use case
definition

bsi.

...making excellence a habit.™

National foreword

This British Standard is the UK implementation of ISO 17458-1:2013.

The UK participation in its preparation was entrusted to Technical Committee AUE/16, Electrical and electronic equipment.

A list of organizations represented on this committee can be obtained on request to its secretary.

This publication does not purport to include all the necessary provisions of a contract. Users are responsible for its correct application.

© The British Standards Institution 2013.
Published by BSI Standards Limited 2013

ISBN 978 0 580 76712 8

ICS 43.040.15

Compliance with a British Standard cannot confer immunity from legal obligations.

This British Standard was published under the authority of the Standards Policy and Strategy Committee on 28 February 2013.

Amendments issued since publication

Date	Text affected
------	---------------

INTERNATIONAL
STANDARD

BS ISO 17458-1:2013

ISO
17458-1

First edition
2013-02-01

**Road vehicles— FlexRay
communications system —**

Part 1:
**General information and use case
definition**

*Véhicules routiers — Système de communications FlexRay —
Partie 1: Information générale et définition de cas d'utilisation*



Reference number
ISO 17458-1:2013(E)

© ISO 2013



COPYRIGHT PROTECTED DOCUMENT

© ISO 2013

All rights reserved. Unless otherwise specified, no part of this publication may be reproduced or utilized in any form or by any means, electronic or mechanical, including photocopying and microfilm, without permission in writing from either ISO at the address below or ISO's member body in the country of the requester.

ISO copyright office
Case postale 56 • CH-1211 Geneva 20
Tel. + 41 22 749 01 11
Fax + 41 22 749 09 47
E-mail copyright@iso.org
Web www.iso.org

Published in Switzerland

Contents

Page

1	Scope	1
2	Terms, definitions, symbols and abbreviated terms	1
2.1	Terms and definitions	1
2.2	Abbreviated terms	4
3	Conventions	4
4	Document overview.....	4
4.1	General	4
4.2	Document overview and structure	5
4.3	Open Systems Interconnection (OSI) model	5
4.4	Document reference according to OSI model	6
5	Use case overview and principles	7
5.1	Basic principles for use case definition.....	7
5.2	Use case clusters	7
6	FlexRay communications system use case definition	8
6.1	UC 1 FlexRay processes.....	8
6.2	UC 2 TT modes in clusters	11
6.3	UC 3 Communication protocol.....	17
6.4	UC 4 Electrical physical layer	20

Foreword

ISO (the International Organization for Standardization) is a worldwide federation of national standards bodies (ISO member bodies). The work of preparing International Standards is normally carried out through ISO technical committees. Each member body interested in a subject for which a technical committee has been established has the right to be represented on that committee. International organizations, governmental and non-governmental, in liaison with ISO, also take part in the work. ISO collaborates closely with the International Electrotechnical Commission (IEC) on all matters of electrotechnical standardization.

International Standards are drafted in accordance with the rules given in the ISO/IEC Directives, Part 2.

The main task of technical committees is to prepare International Standards. Draft International Standards adopted by the technical committees are circulated to the member bodies for voting. Publication as an International Standard requires approval by at least 75 % of the member bodies casting a vote.

Attention is drawn to the possibility that some of the elements of this document may be the subject of patent rights. ISO shall not be held responsible for identifying any or all such patent rights.

ISO 17458-1 was prepared by Technical Committee ISO/TC 22, *Road vehicles*, Subcommittee SC 3, *Electrical and electronic equipment*.

ISO 17458 consists of the following parts, under the general title *Road vehicles — FlexRay communications system*:

- *Part 1: General information and use case definition*
- *Part 2: Data link layer specification*
- *Part 3: Data link layer conformance test specification*
- *Part 4: Electrical physical layer specification*
- *Part 5: Electrical physical layer conformance test specification*

Introduction

The FlexRay communications system is an automotive focused high speed network and was developed with several main objectives which were defined beyond the capabilities of established standardized bus systems like CAN and some other proprietary bus systems. Some of the basic characteristics of the FlexRay protocol are synchronous and asynchronous frame transfer, guaranteed frame latency and jitter during synchronous transfer, prioritization of frames during asynchronous transfer, single or multi-master clock synchronization, time synchronization across multiple networks, error detection and signalling, and scalable fault tolerance.

The FlexRay communications system is defined for advanced automotive control applications. It serves as a communication infrastructure for future generation high-speed control applications in vehicles by providing:

- A message exchange service that provides deterministic cycle based message transport;
- Synchronization service that provides a common time base to all nodes;
- Start-up service that provides an autonomous start-up procedure;
- Error management service that provides error handling and error signalling;
- Wakeup service that addresses the power management needs;

Since start of development the automotive industry world-wide supported the specification development. The FlexRay communications system has been successfully implemented in production vehicles today.

The ISO 17458 series specifies the use cases, the communication protocol and physical layer requirements of an in-vehicle communication network called "FlexRay communications system".

This part of ISO 17458 has been established in order to define the use cases for vehicle communication systems implemented on a FlexRay data link.

To achieve this, it is based on the Open Systems Interconnection (OSI) Basic Reference Model specified in ISO/IEC 7498-1 and ISO/IEC 10731, which structures communication systems into seven layers. When mapped on this model, the protocol and physical layer requirements specified by ISO 17458 are broken into:

- Diagnostic services (layer 7), specified in ISO 14229-1 [3], ISO 14229-4 [5];
- Presentation layer (layer 6), vehicle manufacturer specific;
- Session layer services (layer 5), specified in ISO 14229-2 [4];
- Transport layer services (layer 4), specified in ISO 10681-2 [1];
- Network layer services (layer 3), specified in ISO 10681-2 [1];
- Data link layer (layer 2), specified in ISO 17458-2, ISO 17458-3;
- Physical layer (layer 1), specified in ISO 17458-4, ISO 17458-5;

in accordance with Table 1.

Table 1 — FlexRay communications system specifications applicable to the OSI layers

Applicability	OSI 7 layers	ISO 17458 FlexRay communications system	Vehicle manufacturer enhanced diagnostics
Seven layer according to ISO 7498-1 and ISO/IEC 10731	Application (layer 7)	vehicle manufacturer specific	ISO 14229-1, ISO 14229-4
	Presentation (layer 6)	vehicle manufacturer specific	vehicle manufacturer specific
	Session (layer 5)	vehicle manufacturer specific	ISO 14229-2
	Transport (layer 4)	vehicle manufacturer specific	ISO 10681-2
	Network (layer 3)	vehicle manufacturer specific	
	Data link (layer 2)	ISO 17458-2, ISO 17458-3	
	Physical (layer 1)	ISO 17458-4, ISO 17458-5	

Table 1 shows ISO 17458 Parts 2 – 5 being the common standards for the OSI layers 1 and 2 for the FlexRay communications system and the vehicle manufacturer enhanced diagnostics.

The FlexRay communications system column shows vehicle manufacturer specific definitions for OSI layers 3 – 7.

The vehicle manufacturer enhanced diagnostics column shows application layer services covered by ISO 14229-4 which have been defined in compliance with diagnostic services established in ISO 14229-1, but are not limited to use only with them. ISO 14229-4 is also compatible with most diagnostic services defined in national standards or vehicle manufacturer's specifications. The presentation layer is defined vehicle manufacturer specific. The session layer services are covered by ISO 14229-2. The transport protocol and network layer services are specified in ISO 10681.

Road vehicles — FlexRay communications system — Part 1: General information and use case definition

1 Scope

This part of ISO 17458 gives an overview of the structure and the partitioning of ISO 17458 and shows the relation between the different parts. In addition, it outlines the use case scenarios where the ISO 17458 series will be used. The terminology defined in this part of ISO 17458 is common for all FlexRay communication systems and is used throughout all parts of ISO 17458.

2 Terms, definitions, symbols and abbreviated terms

2.1 Terms and definitions

For the purposes of this document, the following terms and definitions apply.

2.1.1

active star

AS

active element which passes bus signals automatically from one input port to several output ports, where usually a passive net is plugged to each port

NOTE1 An AS refreshes the bus signal slopes and levels; an AS does not refresh the bit-timing.

NOTE2 An AS may be implemented in a monolithic way or a non-monolithic way.

NOTE3 Optionally an AS may have a CC interface included.

2.1.2

branch

component within active star topologies

NOTE A branch can be built from a point-to-point connection, a linear bus or a passive star.

2.1.3

bus driver

BD

physical interface between the CC and the wiring harness

NOTE A BD is a mandatory FlexRay component that converts the data stream of the physical interface and supports the node with a power mode controlling optionally.

2.1.4

cable

FlexRay transmission line.

2.1.5
cluster

communication system of multiple nodes connected via at least one communication channel directly (bus topology), by active stars (star topology) or by a combination of bus and star connections (hybrid topologies)

NOTE Clusters can be coupled by gateways.

2.1.6
communication channel

node connection through which signals are conveyed for the purpose of communication

NOTE FlexRay allows a single CC to distribute data-frames independent from each other on two different hardware paths or topologies. From an abstract view each path is named "communication channel" (short: "channel"). The two channels are distinguished by using the extensions "A" and "B".

2.1.7
communication controller
CC

electronic component in a node that is responsible for implementing the protocol aspects of the FlexRay communications system

2.1.8
communication element
symbol and frame

NOTE FlexRay distinguishes two types of communication elements which can be transmitted on the communication channel: symbols and frames.

2.1.9
communication cycle

one complete instance of the communication structure that is periodically repeated to comprise the media access method of the FlexRay system

NOTE The communication cycle consists of a static segment, an optional dynamic segment, an optional symbol window, and a network idle time.

Figure 1 illustrates the segmentation of a communication cycle during FlexRay's normal operation.

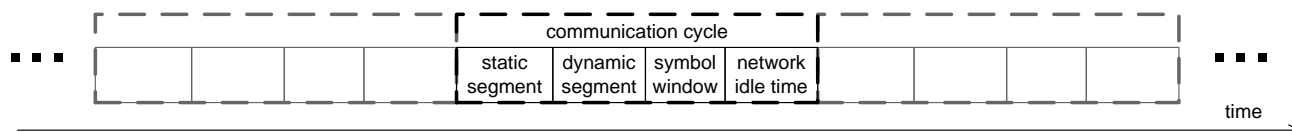

Figure 1 — Segmentation of a communication cycle during normal operation

The static segment is configured into a selectable number of static slots. The segmentation in the time domain is based on FlexRay's distributed clock. FlexRay frames are transmitted synchronously during these static slots.

The dynamic segment is configured into mini slots. They support prioritised event driven transmission of FlexRay frames.

The symbol window is used to transmit FlexRay symbols which support e.g. wake-up of a FlexRay communication system.

The network idle time is used for clock correction.

2.1.10

gateway

node that is connected to two or more independent communication networks that allows information to flow between the networks

2.1.11

host

part of an ECU where the application software is executed, separated by the CHI from the FlexRay protocol engine

NOTE The host offers interfaces which enable the application software to control the CC and the BD.

2.1.12

hybrid topology

design of a communication cycle using various topology components

EXAMPLE An AS with one branch as point-to-point connection, one branch as linear bus and one branch as passive star.

2.1.13

passive net

summary of all possible implementations of passive connections among FlexRay BDs and Ass

NOTE A passive summarizes all point-to-point connections, linear busses and passive stars.

2.1.14

physical layer

BDs, ASs, CC I/O stages, cables, connectors, common mode filters, ESD protection circuits, termination networks etc.

NOTE All timing relevant hard-ware components are included which are needed to transfer communication elements among the protocol machines.

2.1.15

point-to-point

two terminated FlexRay nodes which are linked by a single FlexRay cable without any stub

2.1.16

splice

implementation of a connection-point where 3 or more transmission lines are plugged together.

NOTE A splice may contain passive components to damp radiation, e.g.a splice in a linear bus allows connecting a stub to a FlexRay node.

2.1.17

stub

single FlexRay cable connected to the centre of a passive star or to a linear bus (short: plugged to a splice)

NOTE1 A stub represents a component within passive nets. A stub consists of a single FlexRay cable connected to the centre of a passive star or to a linear bus (short: plugged to a splice).

NOTE2 The stub ends at the BD pins within an FlexRay node.

2.1.18

topology

distributed FlexRay system which consists of several components like nodes, busses, active and passive stars etc.

NOTE The topology represents the non-hierarchical flat geometric structure of a FlexRay communication channel.

2.1.19 wiring harness

summary of all components inside the component "vehicle wiring harness" to transmit FlexRay communication elements

NOTE The FlexRay wiring harness consists of

- connectors to plug ECUs,
- in-line connectors,
- cables,
- splices etc.

2.2 Abbreviated terms

AM	amplitude modulation
AS	active star
BD	bus driver
BD/AS	bus driver or active star
CC	communication controller
CW	continuous wave
ECU	electronic control unit
EMC	electromagnetic compatibility
EPL	electrical physical layer
ESD	electro static discharge
SAP	service access point

3 Conventions

ISO 17458, ISO 10681 [1] and ISO 14229-4 [5] are based on the conventions specified in the OSI Service Conventions (ISO/IEC 10731) [2] as they apply for physical layer, protocol, network & transport protocol and diagnostic services.

4 Document overview

4.1 General

ISO 17458 has been established in order to define common requirements for vehicle communication systems implemented on a FlexRay communication data link.

4.2 Document overview and structure

The ISO 17458 series provides an implementer with all documents and references required to support the implementation of the requirements related to.

- Part 1: General information and use case definitions
This part provides an overview of the document set and structure along with the use case definitions and a common set of resources (definitions, references) for use by all subsequent parts.
- Part 2: Data link layer specification
This part specifies the requirements for implementations of the FlexRay protocol on the logical level of abstraction. Hardware related properties are hidden in the defined constraints.
- Part 3: Data link layer conformance test specification
This part specifies tests to check the compliance of a given protocol implementation (logical level of abstraction) to the Data link layer specification.
- Part 4: Electrical physical layer specification
This part specifies the requirements for implementations of active hardware components which are necessary to interconnect several distributed protocol implementations. Requirements for necessary passive components are specified partly.
- Part 5: Electrical physical layer conformance test specification
This part specifies tests to check the compliance of a given active hardware component implementation to the electrical physical layer specification.

4.3 Open Systems Interconnection (OSI) model

ISO 17458 is based on the Open Systems Interconnection (OSI) Basic Reference Model as specified in ISO/IEC 7498 which structures communication systems into seven layers.

All parts of ISO 17458 are guided by the OSI service conventions as specified in ISO/IEC 10731 to the extent that they are applicable to diagnostic services. These conventions define the interaction between the service user and the service provider through service primitives.

The aim of this subclause is to give an overview of the OSI model and show how it has been used as a guideline for this part of ISO 17458. It also shows how the OSI service conventions have been applied to ISO 17458.

The OSI model structures data communication into seven layers called (top down) *Application layer* (layer 7), *Presentation layer*, *Session layer*, *Transport layer*, *Network layer*, *Data Link layer* and *Physical layer* (layer 1). A subset of these layers is used in ISO 17458.

ISO 17458 specifies data link layer and physical layer for the FlexRay communications system.

The purpose of each layer is to provide services to the layer above. The active parts of each layer, implemented in software, hardware or any combination of software and hardware, are called *entities*. In the OSI model, communication takes place between entities of the same layer in different nodes. Such communicating entities of the same layer are called *peer entities*.

The services provided by one layer are available at the *Service Access Point* (SAP) of that layer. The layer above can use them by exchanging data parameters

ISO 17458 distinguishes between the services provided by a layer to the layer above it and the protocol used by the layer to send a message between the peer entities of that layer. The reason for this distinction is to make the services, especially the application layer services and the transport layer services, reusable also for other types of networks than FlexRay. In this way the protocol is hidden from the service user and it is possible to change the protocol if special system requirements demand it.

4.4 Document reference according to OSI model

Figure 2 illustrates the document references.

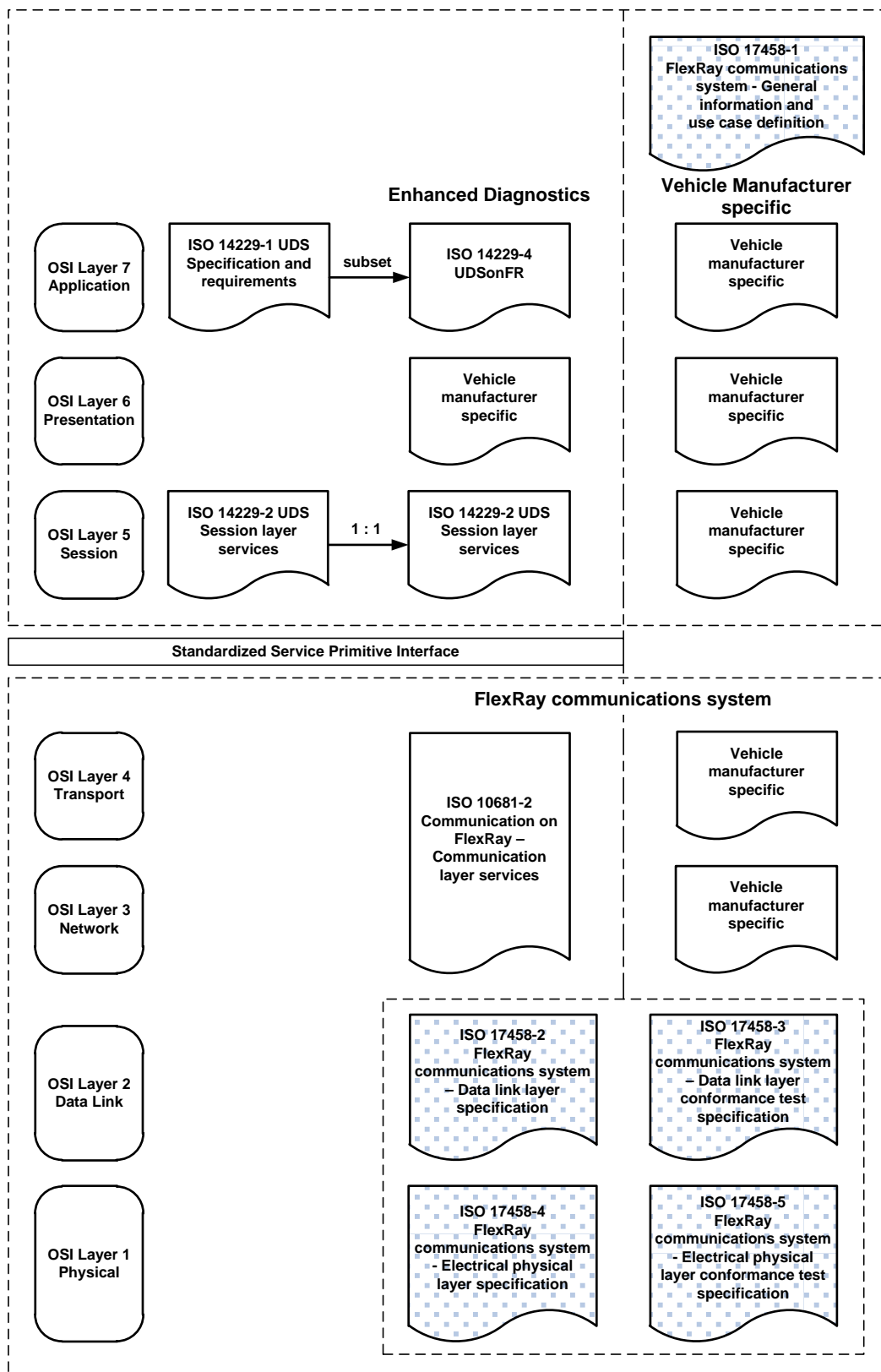

Figure 2 — FlexRay document reference according to OSI model

5 Use case overview and principles

5.1 Basic principles for use case definition

Basic principles have been established as a guideline to define the use cases:

- pointing out features which support usual operating modes of networked systems in OEMs products;
- pointing out features which support future expected properties of networked systems in OEMs products;
- comparing the contrast between normal operating functionalities in the absence of errors and limp-home operation functionalities in the presence of errors;
- distributed applications inside vehicles expect completely different properties of their interconnecting networks. FlexRay systems are allowed being implemented and parameterized by taking use of various features. These stress fields are reflected by several use cases.

5.2 Use case clusters

This chapter defines use case clusters of the FlexRay communications system.

Table 2 provides an overview of the main FlexRay use case clusters. A main FlexRay use case cluster may have one or more use case definition.

Table 2 — FlexRay communications system main use case clusters

#	Main title of use case cluster	Brief description
1	FlexRay processes	The purpose of these use cases requires basic functionalities of a FlexRay system when being built in vehicles and when being used for the distribution of application data during the various operating modes of vehicles.
2	TT-D, TT-L and TT-E clusters	The purpose of these use cases is the description of various methods to provide a common time base to all FlexRay nodes communicating among each other.
3	Communication protocol	The purpose of these use cases is the description of the protocol driven property range of systems and applications when using FlexRay for their internal communication.
4	Electrical physical layer	The purpose of these use cases is the description of the electrical physical layer properties when interconnecting the logical links of the distributed FlexRay ECUs by electrical hardware components inside a vehicle.

6 FlexRay communications system use case definition

6.1 UC 1 FlexRay processes

6.1.1 UC 1.1 Execute normal communication cycle

Table 3 specifies the use case to execute normal communication cycle.

Table 3 — UC 1.1 Execute normal communication cycle

Actor	Communication module
Goal	Run the communication and the observation procedures during the communication cycle (static segment, the dynamic segment, the symbol window and the network idle time).
Use case input	Start-up complete
Use case output	Data stream to and from the logical link (physical layer), data stream to and from the host, control stream to and from the host.
Brief description	The use case includes the detailed functionality, behaviour and data structures of FlexRay in its main operating mode when running the communication cycle. Examples are: <ul style="list-style-type: none"> — receive communication elements; — transmit communication elements. <p>The complete functionality is implemented inside the communication controller.</p>

6.1.2 UC 1.2 Check for wakeup condition

Table 4 specifies the use case to check for wakeup condition.

Table 4 — UC 1.2 Check for wakeup condition

Actor	Bus driver module
Goal	Monitoring for presence of wake-up events and signal them.
Use case input	Low power mode active.
Use case output	Signal available which announces a detected wake-up event.
Brief description	The bus-driver module monitors optionally the availability of wake-up conditions at its interfaces. Several types are distinguished: <ul style="list-style-type: none"> — remote wake-up from the bus due to wakeup symbols; — remote wake-up from the bus due to payload; — local wakeup.

6.1.3 UC 1.3 Configure communication module

Table 5 specifies the use case to configure communication module.

Table 5 — UC 1.3 Configure communication module

Actor	Host
Goal	Configure the communication module to ensure the participation in the FlexRay communication.
Use case input	Set of communication parameters
Use case output	Communication module is parameterized faultless.
Brief description	<p>The communication module (hardware implementation of the FlexRay protocol) offers a broad range of features to be adjusted or selected by the system designer. The deduced set of parameters initializes the module to take part in the FlexRay communication. Examples of what to parameterize are:</p> <ul style="list-style-type: none"> — communication schedule; — transmit message buffer configuration; — receive message buffer configuration.

6.1.4 UC 1.4 Clock synchronization

Table 6 specifies the use case to clock synchronization.

Table 6 — UC 1.4 Clock synchronization

Actor	Communication module
Goal	Distributed clocks based on marginally differing local cycles shall be synchronized during start-up and re-synchronized during normal communication.
Use case input	Sampled local time-stamps based on faultless communication elements on the bus.
Use case output	Net wide synchronized local clock.
Brief description	<p>The FlexRay protocol uses two different procedures to synchronize protocol internal local clocks:</p> <ul style="list-style-type: none"> — Each communication module individually synchronizes itself to the FlexRay communication system by observing the timing of transmitted sync frames from other communication modules; — Each communication module individually synchronizes itself to the FlexRay communication system by observing timing information transmitted from a synchronization master. <p>The local clocks are going to be decelerated and / or accelerated to guarantee a net wide maximal deviation.</p>

6.1.5 UC 1.5 Start communication module

Table 7 specifies the use case to start communication module.

Table 7 — UC 1.5 Start communication module

Actor	Networked system
Goal	A non-communicating FlexRay system (usually in a low-power mode) shall establish a regular communication on demand.
Use case input	Wake-up event at any FlexRay node.
Use case output	Established communication among the connected and powered FlexRay nodes.
Brief description	The FlexRay protocol supports strategies to wake-up each powered FlexRay node and to synchronize their local communication modules. The strategies are based on transmitted wakeup and start-up communication elements.

6.1.6 UC 1.6 Shutdown communication module

Table 8 specifies the use case to shutdown communication module.

Table 8 — UC 1.6 Shutdown communication module

Actor	Host
Goal	The communication module of a node executes on demand the termination of node's participation in the regular communication
Use case input	The host commands to stop node's participation in the regular communication.
Use case output	The mentioned node finished the participation in the regular communication.
Brief description	The FlexRay communication module supports strategies to finish the participation in a regular communication. After the successful shut-down the mentioned node does not participate any longer in the optionally on-going regular communication.

6.1.7 UC 1.7 Repeating function & branch error handling

Table 9 specifies the use case to repeating function & branch error handling.

Table 9 — UC 1.7 Repeating function & branch error handling

Actor	Repeater module (active star)
Goal	Passing of FlexRay communication elements from one branch to all other branches (repeating function) in the absence of any error, suppressing the influence of a branch, if there is any error in the branch present.
Use case input	Communicating FlexRay nodes which are connected via an active star.
Use case output	Faultless communication among the FlexRay nodes which are connected to faultless branches.
Brief description	<p>An active star supervises each of its branches independently for the presence of errors:</p> <ul style="list-style-type: none"> — Noise; — short circuit to ground or the battery; — broken bus-line; — short circuit among the bus-lines. <p>In case of "no error" an active star passes FlexRay communication elements from any receiving branch to the other (transmitting) branches (repeater function).</p> <p>In case of "error detected" the corresponding branch will be deactivated and excluded from the repeating function.</p>

6.2 UC 2 TT modes in clusters

6.2.1 Basic principles for TT mode definition

FlexRay supports a common time base for all nodes which are connected to a single cluster and to all nodes which are connected to several clusters coupled by gateways.

Figure 3 illustrates an example of two coupled FlexRay clusters.

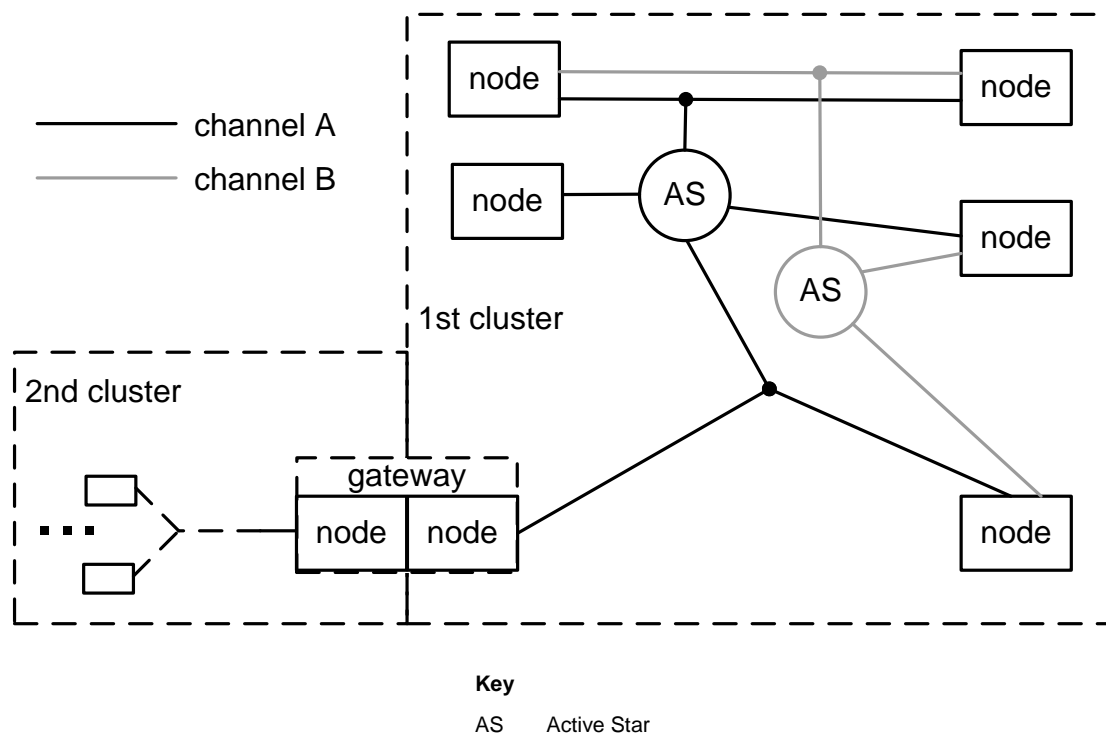

Figure 3 — Example of a FlexRay communication cluster consisting of 2 channels, two active stars and a gateway to a 2nd cluster

Three basic methods are supported to synchronize the distributed clocks:

- TT-D
FlexRay communication modules operating in time-triggered distributed (TT-D) method use a fault tolerant distributed clock synchronization mechanism;
- TT-L
FlexRay communication modules operating in time-triggered local-controlled (TT-L) method use a clock synchronization mechanism based on the local clock of a single node;
- TT-E
FlexRay communication modules operating in time-triggered external-controlled (TT-E) method derive their clock synchronization directly from the clock synchronization of another FlexRay cluster via a time gateway.

Three clusters with various TT-methods are pointed out as use case examples. Additional combinations or use cases are possible.

6.2.2 UC 2.1 TT-D cluster

Table 10 specifies the use case for a TT-D cluster.

Table 10 — UC 2.1 TT-D cluster

Actor	System designer
Goal	FlexRay communication on one channel where slot-timing is based on distributed fault tolerant clock synchronizations mechanisms
Use case input	FlexRay message scheduling according to applications' requirements, robust against faulty local clocks
Use case output	Clocks are cluster-wide synchronized to enable a regular communication.
Brief description	<p>Message scheduling is based on time. To achieve a common understanding of time the local clocks are synchronized cluster-wide.</p> <p>Two kinds of nodes are distinguished:</p> <ul style="list-style-type: none"> — Sync nodes: These nodes participate in the clock synchronization mechanism and they provide timing information to all other nodes; — Non-sync nodes: These nodes receive the timing information provided by the sync nodes. Their local clocks do not influence any other clock.

Figure 4 illustrates an example of a TT-D cluster.

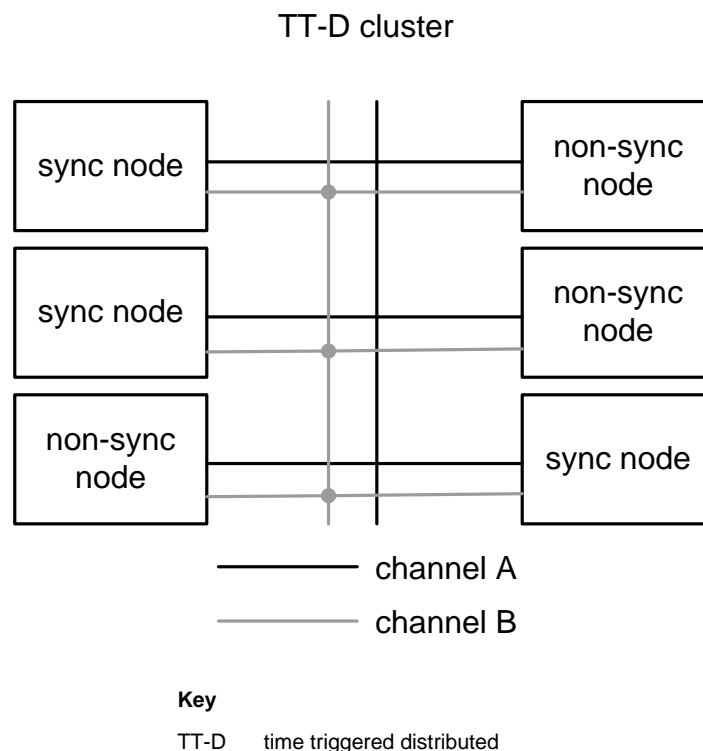

Figure 4 — Example of a FlexRay TT-D cluster

6.2.3 UC 2.2 TT-L cluster

Table 11 specifies the use case for a TT-L cluster.

Table 11 — UC 2.2 TT-L cluster

Actor	System designer
Goal	FlexRay communication on one channel where slot-timing is based on the clock of a single pre-defined node
Use case input	FlexRay message scheduling according to applications' requirements synchronized to a pre-defined node's clock
Use case output	clocks are cluster-wide synchronized to enable a regular communication
Brief description	<p>Message scheduling is based on time. To achieve a common understanding of time the local clocks are synchronized cluster-wide. In a TT-L-cluster a single node provides the timing information to all other nodes.</p> <p>Two kinds of nodes are distinguished:</p> <ul style="list-style-type: none"> — TT-L coldstart node: This node is the only node in the cluster which provides timing information. The clock of this node dictates the clocks of the other nodes in the cluster; — Non-sync nodes: These nodes receive the timing information provided by the TT-L coldstart node. Their local clocks do not influence any other clock.

Figure 5 illustrates an example of a FlexRay TT-L cluster.

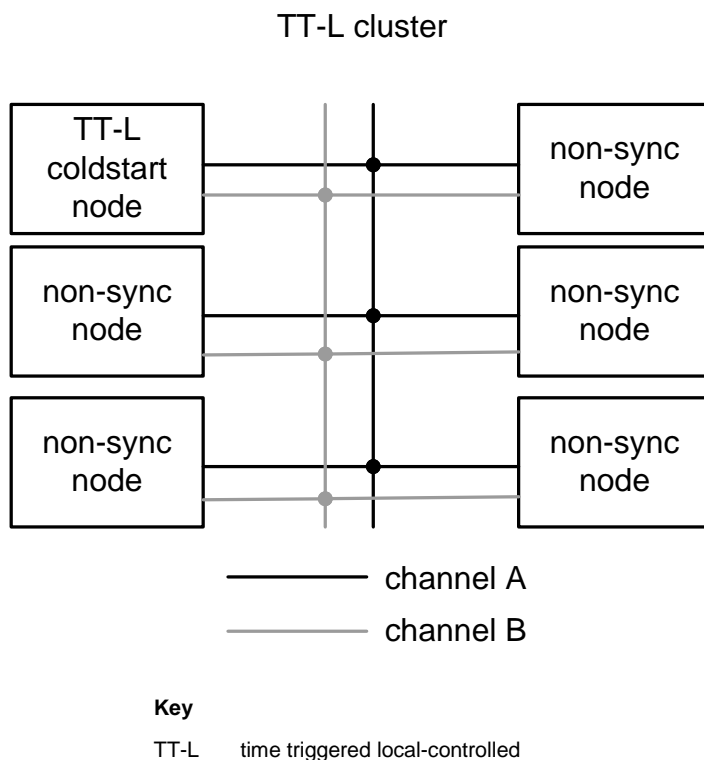

Figure 5 — Example of a FlexRay TT-L cluster

6.2.4 UC 2.3 TT-D cluster linked with a TT-E cluster

Table 12 specifies the use case for TT-D cluster linked with a TT-E cluster.

Table 12 — UC 2.3 TT-D cluster linked with a TT-E cluster

Actor	System designer
Goal	Synchronized operation of two FlexRay clusters coupled via a gateway.
Use case input	FlexRay message scheduling according to applications' requirements synchronized among each other to a distributed clock.
Use case output	Clocks are net-wide synchronized to enable a regular communication.
Brief description	<p>Message scheduling is based on time. To achieve a common understanding of time the local clocks are synchronized cluster-wide. The nodes in the TT-D cluster (time source cluster) use the time synchronization mechanism as described in Table 10. The nodes in the TT-E cluster (time sink cluster) are connected to the TT-D cluster via a time gateway. The nodes in the gateway pass the timing information from the time source cluster to the time sink cluster. Three kinds of nodes are distinguished:</p> <ul style="list-style-type: none"> — Sync nodes: These nodes participate in the clock synchronization mechanism and they provide timing information to all other nodes; — TT-E coldstart nodes: These nodes provide the timing information in the TT-E cluster. The clocks of these nodes dictate the clocks of the non-sync nodes in the TT-E cluster. A TT-E coldstart node is part of a time gateway and is located on the time sink side. It gets its time information from the time source side which is a node in a separate TT-D, TT-L or a TT-E cluster; — Non-sync nodes: These nodes receive the timing information provided by the sync nodes or the TT-E coldstart nodes. Their local clocks do not influence any other clock.

Figure 6 illustrates an example of a FlexRay TT-D cluster linked with two TT-E clusters via TT-E gateways.

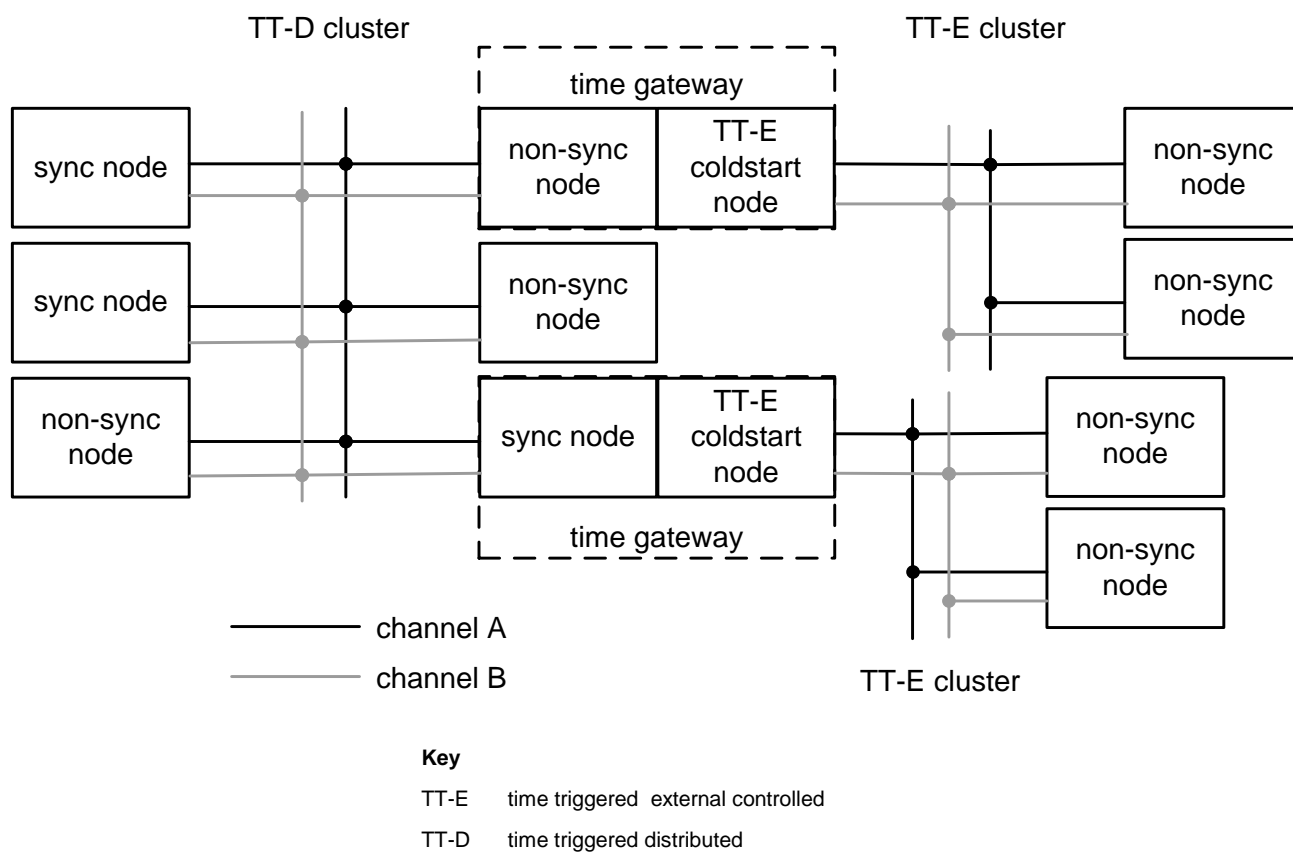

Figure 6 — Example of a FlexRay TT-D cluster linked with two TT-E clusters via time gateways

6.3 UC 3 Communication protocol

6.3.1 UC 3.1 Flexibility in communication schemes

Table 13 specifies the use case to flexibility in communication schemes

Table 13 — UC 3.1 Flexibility in communication schemes

Actor	System designer
Goal	The system designer adjusts the FlexRay communication cycle best to his requirements.
Use case input	Communication requirements driven by automotive networked applications.
Use case output	Communication cycle design
Brief description	<p>The FlexRay protocol offers the system designer a broad range of parameters to adjust the communication cycle to the system requirements best.</p> <p>Examples are:</p> <ul style="list-style-type: none"> — selectable fragmentation of the communication cycle in dynamic part and static part; — selectable range of communication cycle times; — selectable multiplexed slots to support a broad range of message cycles at a fixed communication cycle time; — selectable protocol parameters to be adapted to the EPL topology timing properties.

6.3.2 UC 3.2 Scalable expansion stages

Table 14 specifies the use case to scalable expansion stages.

Table 14 — UC 3.2 Scalable expansion stages

Actor	System designer
Goal	The system designer adjusts the FlexRay communication options best to his requirements.
Use case input	Communication requirements driven by the automotive networked application.
Use case output	Selected communication options
Brief description	<p>The FlexRay protocol offers the system designer a broad range of selectable communication options to meet the requirements optimally.</p> <p>Examples are:</p> <ul style="list-style-type: none"> — one channel at 2,5, 5 or 10 MBit / s; — two channels each at 2,5, 5 or 10 MBit / s to get finally 5, 10 or 20 MBit / s; — two channels each at 2,5, 5 or 10 MBit / s with redundant communication to support best availability; — two channels each at 2,5, 5 or 10 MBit / s in which redundant communication and increased data throughput is combined.

6.3.3 UC 3.3 Suppressible glitches

Table 15 specifies the use case to Suppressible glitches.

Table 15 — UC 3.3 suppressible glitches

Actor	System in operation
Goal	The communication shall only be influenced minimal by any electrical disturbance which may probably lead to glitches and faulty samples inside the communication modules' RxD input path.
Use case input	Automotive electrical stress, e. g.: ISO 7637-3:1995, test pulses 3a and 3b
Use case output	Faultless final sampling of the serial data stream.
Brief description	A stepped filtering approach is realized in FlexRay. First the BD shall be insensible against electromagnetic stress and shall provide the CC with a perfect data stream. Second the FlexRay protocol includes a glitch filter to suppress faulty samples. The filter is able to suppress one faulty sample or two faulty samples in a row. The glitch filter delays the sampled data stream by 3 sample periods.

6.3.4 UC 3.4 Composability

Table 16 specifies the use case to composability.

Table 16 — UC 3.4 Composability

Actor	System designer
Goal	Reusability of two distributed independent functions, which were validated and verified separately from each other.
Use case input	Two separately validated and verified distributed functions, independent from each other.
Use case output	One common validated and verified distributed system consisting of two independent and distributed functions.
Brief description	The communication scheme timing in the static part of the FlexRay communication cycle is pre-defined and deterministic. It is neither influenced by priorities nor influenced by the payload. This allows running two independently developed and tested distributed functions together in one FlexRay system if both functions use separate slots. A re-test of the integrated system is not necessary.

6.3.5 UC 3.5 Synchronisation of application tasks

Table 17 specifies the use case to synchronisation of application tasks.

Table 17 — UC 3.5 Synchronisation of application tasks

Actor	Application designer
Goal	Each task of a distributed application may run synchronously to all the other involved tasks.
Use case input	Absolute timing requirements and tolerance of tasks supporting distributed applications.
Use case output	Guaranteed timing constrains or real time error signalling.
Brief description	The FlexRay communication system supports to run distributed tasks synchronously to each other. The FlexRay timing based on the synchronized distributed clocks can be used to generate timing events for the activation of local tasks. The clocks can be synchronized inside a FlexRay topology as well as among several FlexRay topologies which are coupled among each other by gateways.

6.3.6 UC 3.6 Communication controller implementation conformance tests

Table 18 specifies the use case to communication controller implementation conformance tests.

Table 18 — UC 3.6 Communication controller implementation conformance tests

Actor	System responsible
Goal	Any system responsible (at the OEM, ECU or silicon manufacturer) shall have the possibility to order one test house at least. It shall offer the operation of a standardized conformance test.
Use case input	Model or sample of a protocol implementation.
Use case output	Report "conformance between the specification and the digital model of the protocol implementation CC_name ^a "
Brief description	The conformance test checks of the data link layer specification against the model or sample of a protocol implementation. Some dedicated HW parameters documented in the data sheet of the corresponding CC implementation are checked against ISO 17458-4 (e. g. HW-related symmetric and asymmetric delays on the CCs' internal communication path).
^a type of the communication controller implementation used in the conformance test	

6.3.7 UC 3.7 Distributed closed loop control application

Table 19 specifies the use case to distributed closed loop control application.

Table 19 — UC 3.7 Distributed closed loop control application

Actor	Application designer
Goal	Enable to run closed loop control systems with distributed control modules.
Use case input	Closed loop control data to be distributed among the networked control modules.
Use case output	The closed loop control data is distributed cyclically within guaranteed real-time limits.
Brief description	The FlexRay protocol guarantees the distribution of cyclic data among networked applications. The cycles are based on clocks which are implemented inside each protocol implementation. The achievable accuracy (e. g. a few μ s) depends for example on the minimal and maximal propagation delay of frames. Local tasks can be synchronized to interrupts coupled to the slots.

6.4 UC 4 Electrical physical layer

6.4.1 UC 4.1 Partial networking

Table 20 specifies the use case to partial networking.

Table 20 — UC 4.1 Partial networking

Actor	Autonomously or user-driven system in operation
Goal	Faultless communication via a communication channel although several connected nodes are not powered (broken power line or power supply switched off).
Use case input	A node connected to the passive net of a channel is un-powered due to failure or due to system operating mode.
Use case output	Faultless communication among the supplied nodes.
Brief description	An un-powered node behaves high ohmic at the bus lines (negligible quiescent current) and influences the communication among the remaining nodes only marginally.

6.4.2 UC 4.2 Electrical stress

Table 21 specifies the use case to electrical stress.

Table 21 — UC 4.2 Electrical stress

Actor	System in operation
Goal	The communication may not be influenced by any electrical disturbances according to OEMs' or ECU-suppliers' EMC specifications.
Use case input	FlexRay topology with present automotive electrical stress, e. g.: AM and CW irradiated signal, test pulses, ground shift.
Use case output	Faultless communication among the connected stressed und un-stressed components and nodes.
Brief description	The communication procedures e. g. wakeup, normal communication and shut down are going to operate faultlessly even in the presence of electrical disturbances. The components of the EPL are able to suppress electrical influences.

6.4.3 UC 4.3 ESD protection

Table 22 specifies the use case to ESD protection.

Table 22 — UC 4.3 ESD protection

Actor	Worker in the production or in the garage.
Goal	The BD may not be damaged by workers' usual handling procedures.
Use case input	The worker touches the accessible BD / AS connections with his fingers or the worker establishes the connection between the wiring harness and the BD / AS containing ECUs.
Use case output	No (pre-)damage may happen to the BD in the ECU.
Brief description	ESD caused by usual handling procedures is not going to (pre-) damage the BD / AS in the ECU.

6.4.4 UC 4.4 Babbling idiot protection

Table 23 specifies the use case to babbling idiot protection.

Table 23 — UC 4.4 Babbling idiot protection

Actor	System in operation
Goal	Decoupling of a passive net which is connected to a permanently transmitting node.
Use case input	Permanently (idle never occurs) communication on a passive net.
Use case output	De-activation of the affected passive net by the AS.
Brief description	The AS detects an error and switches off the involved passive net (branch). The branch will be re-activated in case of detected faultless state of the affected passive net (branch).

6.4.5 UC 4.5 Error confinement

Table 24 specifies the use case to error confinement.

Table 24 — UC 4.5 Error confinement

Actor	System in operation
Goal	Errors which occur in a passive net may not influence the communication inside and among the other passive nets of the same communication channel permanently. A temporarily disturbance of the communication is possible.
Use case input	Any error according to specification, e. g. short circuit of a bus wire to ground, to the battery or among each other, broken line.
Use case output	De-activation of the faulty passive net (branch) by the AS.
Brief description	The AS detects an error and switches off the involved passive net (branch). The branch will be re-activated in case of detected faultless state of the affected passive net (branch).

6.4.6 UC 4.6 Wake-up during operation

Table 25 specifies the use case to wake-up during operation.

Table 25 — UC 4.6 Wake-up during operation

Actor	System in operation
Goal	Wake-up of nodes which are in low-power during an on-going regular communication
Use case input	Any node is in low-power mode although an on-going regular communication (due to e. g.: a long start-up delay, temporary watchdog-resets or non-interruptible commands)
Use case output	The affected node will be woken up.
Brief description	Several mechanisms are available which guarantee that a BD / AS detects wake-up events during a regular communication. The detection is based on the transmission of dedicated communication elements.

6.4.7 UC 4.7 Adaptable topology

Table 26 specifies the use case to adaptable topology.

Table 26 — UC 4.7 Adaptable topology

Actor	System designer
Goal	The system designer may adjust the FlexRay topology best to his requirements.
Use case input	System designers' communication requirements (e. g. number and location of the FlexRay nodes, data rate, availability) and the OEM specific boundary conditions (e. g.: wiring harness topology, cables, in-line connectors, EMC stress levels)
Use case output	FlexRay topology which meets the requirements optimally.
Brief description	ISO 17458-4 offers the possibility to adjust the topology by using several basic designs like point-to-point nets, passive busses, passive stars and active stars. Different termination concepts are described. Procedures to check the communication quality is specified (e. g. bit-deformations on the path and signal masks). If implementing two channels different topologies can be chosen for each of them.

Figure 7 illustrates examples of different passive and active topologies (single channel use case).

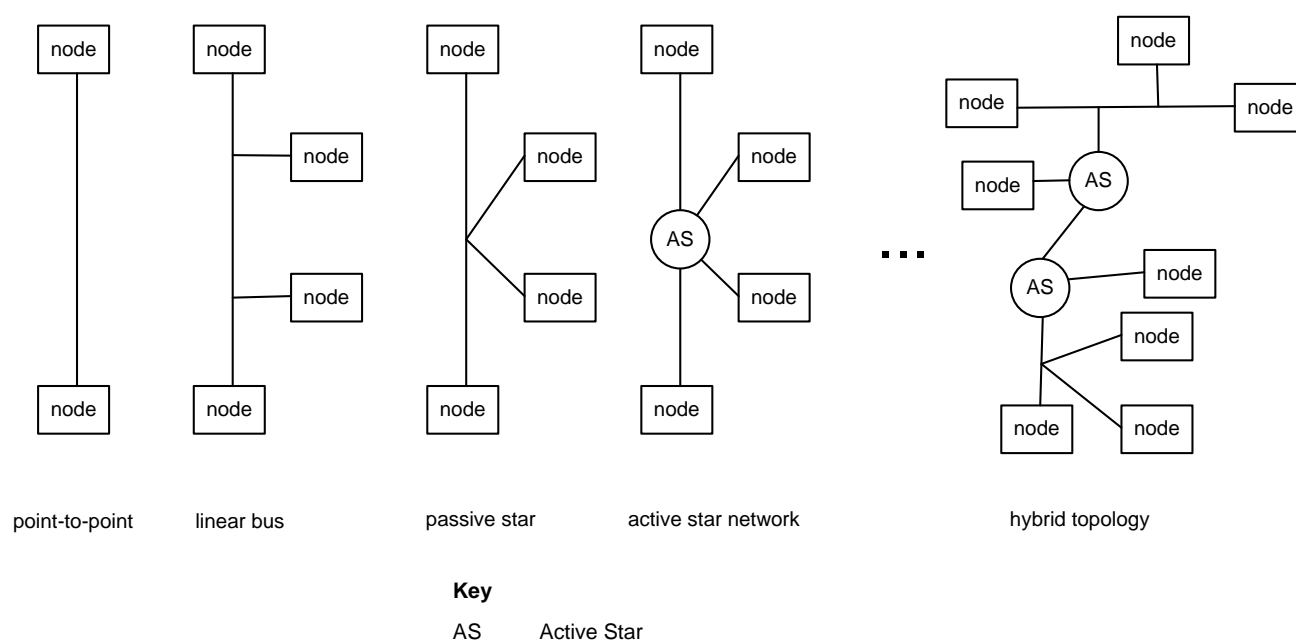

Figure 7 — Example of passive and active FlexRay topologies (single channel use case)

6.4.8 UC 4.8 Bus driver implementation conformance tests

Table 27 specifies the use case to BD releases.

Table 27 — UC 4.8 Bus driver implementation conformance tests

Actor	System responsible
Goal	Any system responsible (at the OEM, ECU or silicon manufacturer) shall have the possibility to order one test house at least. It shall offer the operation of a standardized conformance test.
Use case input	Collection of BD and / or AS samples (e. g. new design, re-design, metal-fix etc).
Use case output	Report "conformance between the specification and the BD type BD_name ^a and AS type AS_name ^b "
Brief description	The conformance test checks ISO 17458-4 against the BD / AS data sheet and a collection of BD / AS samples built in a topology consisting of passive and active networks.
^a	type of the BD implementation used in the conformance test
^b	type of the AS implementation used in the conformance test

Bibliography

- [1] ISO 10681 (all parts); *Road vehicles — Communication on FlexRay*
- [2] ISO/IEC 10731, *Information technology — Open Systems Interconnection — Basic Reference Model — Conventions for the definition of OSI services*
- [3] ISO 14229-1:2012, *Road vehicles — Unified diagnostic services (UDS) — Part 1: Specification and requirements*
- [4] ISO 14229-2:2012, *Road vehicles — Unified diagnostic services (UDS) — Part 2: Session layer services*
- [5] ISO 14229-4:2012, *Road vehicles — Unified diagnostic services (UDS) — Part 4: Unified diagnostic services on FlexRay implementation (UDSonFR)*
- [6] [Z100] ITU-T Recommendation Z.100 (03/93), *Programming Languages - CCITT Specification and Description Language (SDL)*, International Telecommunication Union, Geneva, 1993.
Source: <http://www.itu.int/rec/T-REC-Z.100-199303-S/en>
- [7] ISO/IEC 7498-1, *Information technology — Open Systems Interconnection — Basic Reference Model: The Basic Model*
- [8] ISO 17458-2, *Road vehicles — FlexRay communications system — Part 2: Data link layer specification*
- [9] ISO 17458-3, *Road vehicles — FlexRay communications system — Part 3: Data link layer conformance test specification*
- [10] ISO 17458-4, *Road vehicles — FlexRay communications system — Part 4: Electrical physical layer specification*
- [11] ISO 17458-5, *Road vehicles — FlexRay communications system — Part 5: Electrical physical layer conformance test specification*

British Standards Institution (BSI)

BSI is the national body responsible for preparing British Standards and other standards-related publications, information and services.

BSI is incorporated by Royal Charter. British Standards and other standardization products are published by BSI Standards Limited.

About us

We bring together business, industry, government, consumers, innovators and others to shape their combined experience and expertise into standards-based solutions.

The knowledge embodied in our standards has been carefully assembled in a dependable format and refined through our open consultation process. Organizations of all sizes and across all sectors choose standards to help them achieve their goals.

Information on standards

We can provide you with the knowledge that your organization needs to succeed. Find out more about British Standards by visiting our website at bsigroup.com/standards or contacting our Customer Services team or Knowledge Centre.

Buying standards

You can buy and download PDF versions of BSI publications, including British and adopted European and international standards, through our website at bsigroup.com/shop, where hard copies can also be purchased.

If you need international and foreign standards from other Standards Development Organizations, hard copies can be ordered from our Customer Services team.

Subscriptions

Our range of subscription services are designed to make using standards easier for you. For further information on our subscription products go to bsigroup.com/subscriptions.

With **British Standards Online (BSOL)** you'll have instant access to over 55,000 British and adopted European and international standards from your desktop. It's available 24/7 and is refreshed daily so you'll always be up to date.

You can keep in touch with standards developments and receive substantial discounts on the purchase price of standards, both in single copy and subscription format, by becoming a **BSI Subscribing Member**.

PLUS is an updating service exclusive to BSI Subscribing Members. You will automatically receive the latest hard copy of your standards when they're revised or replaced.

To find out more about becoming a BSI Subscribing Member and the benefits of membership, please visit bsigroup.com/shop.

With a **Multi-User Network Licence (MUNL)** you are able to host standards publications on your intranet. Licences can cover as few or as many users as you wish. With updates supplied as soon as they're available, you can be sure your documentation is current. For further information, email bsmusales@bsigroup.com.

BSI Group Headquarters

389 Chiswick High Road London W4 4AL UK

Revisions

Our British Standards and other publications are updated by amendment or revision.

We continually improve the quality of our products and services to benefit your business. If you find an inaccuracy or ambiguity within a British Standard or other BSI publication please inform the Knowledge Centre.

Copyright

All the data, software and documentation set out in all British Standards and other BSI publications are the property of and copyrighted by BSI, or some person or entity that owns copyright in the information used (such as the international standardization bodies) and has formally licensed such information to BSI for commercial publication and use. Except as permitted under the Copyright, Designs and Patents Act 1988 no extract may be reproduced, stored in a retrieval system or transmitted in any form or by any means – electronic, photocopying, recording or otherwise – without prior written permission from BSI. Details and advice can be obtained from the Copyright & Licensing Department.

Useful Contacts:

Customer Services

Tel: +44 845 086 9001

Email (orders): orders@bsigroup.com

Email (enquiries): cservices@bsigroup.com

Subscriptions

Tel: +44 845 086 9001

Email: subscriptions@bsigroup.com

Knowledge Centre

Tel: +44 20 8996 7004

Email: knowledgecentre@bsigroup.com

Copyright & Licensing

Tel: +44 20 8996 7070

Email: copyright@bsigroup.com



...making excellence a habit.™