

BS ISO 17364:2013



BSI Standards Publication

# Supply chain applications of RFID — Returnable transport items (RTIs) and returnable packaging items (RPIs)

**bsi.**

...making excellence a habit.™

**National foreword**

This British Standard is the UK implementation of ISO 17364:2013. It supersedes BS ISO 17364:2009, which is withdrawn.

The UK participation in its preparation was entrusted to Technical Committee IST/34, Automatic identification and data capture techniques.

A list of organizations represented on this committee can be obtained on request to its secretary.

This publication does not purport to include all the necessary provisions of a contract. Users are responsible for its correct application.

© The British Standards Institution 2013.  
Published by BSI Standards Limited 2013.

ISBN 978 0 580 70608 0

ICS 35.240.60; 55.020

**Compliance with a British Standard cannot confer immunity from legal obligations.**

This British Standard was published under the authority of the Standards Policy and Strategy Committee on 31 March 2013.

**Amendments issued since publication**

Date	Text affected
------	---------------

---

INTERNATIONAL  
STANDARD

**ISO**  
**17364**

Second edition  
2013-03-01

---

---

**Supply chain applications of RFID —  
Returnable transport items (RTIs) and  
returnable packaging items (RPIs)**

*Applications de chaîne d'approvisionnement de RFID — Éléments  
restituables de transport (RTIs) et éléments d'emballage  
restituables (RPIs)*



Reference number  
ISO 17364:2013(E)

© ISO 2013



**COPYRIGHT PROTECTED DOCUMENT**

© ISO 2013

All rights reserved. Unless otherwise specified, no part of this publication may be reproduced or utilized otherwise in any form or by any means, electronic or mechanical, including photocopying, or posting on the internet or an intranet, without prior written permission. Permission can be requested from either ISO at the address below or ISO's member body in the country of the requester.

ISO copyright office  
Case postale 56 • CH-1211 Geneva 20  
Tel. + 41 22 749 01 11  
Fax + 41 22 749 09 47  
E-mail [copyright@iso.org](mailto:copyright@iso.org)  
Web [www.iso.org](http://www.iso.org)

Published in Switzerland

# Contents

Page

<b>Foreword</b> .....	<b>v</b>
<b>Introduction</b> .....	<b>vi</b>
<b>1 Scope</b> .....	<b>1</b>
<b>2 Conformance and performance specifications</b> .....	<b>1</b>
<b>3 Normative references</b> .....	<b>1</b>
<b>4 Terms and definitions</b> .....	<b>3</b>
<b>5 Concepts</b> .....	<b>5</b>
5.1 Differentiation between this layer and the preceding layers.....	5
5.2 Unique RTI and RPI identification.....	7
5.3 Other identification requirements.....	9
<b>6 Differentiation within this layer</b> .....	<b>9</b>
<b>7 Data content</b> .....	<b>11</b>
7.1 Introduction.....	11
7.2 System data elements.....	12
7.3 Tag structure.....	12
7.4 Protocol control (PC) bits.....	14
7.5 Data elements.....	15
7.6 Traceability.....	16
7.7 Combined RTI/RPI and transport unit data.....	16
7.8 Unique item serialization.....	17
<b>8 Data security</b> .....	<b>17</b>
8.1 Confidentiality.....	17
8.2 Data integrity.....	17
8.3 Data preservation.....	18
8.4 Interrogator authentication.....	18
8.5 Non-repudiation/audit trail.....	18
<b>9 Identification of RFID labelled material</b> .....	<b>18</b>
<b>10 Human readable information</b> .....	<b>18</b>
10.1 Human readable interpretation.....	18
10.2 Human readable translation.....	19
10.3 Data titles.....	19
10.4 Backup.....	19
<b>11 Tag operation</b> .....	<b>20</b>
11.1 Data protocol.....	20
11.2 Minimum performance requirements (range and rate).....	20
11.3 Environmental parameters.....	20
11.4 Tag orientation.....	21
11.5 Packaging material.....	21
11.6 Shock loads and abrasions.....	21
11.7 Tag lifetime.....	21
11.8 Minimum system reliability.....	21
11.9 Air interface.....	22
11.10 Memory requirements for application.....	22
11.11 Sensor interface, if applicable.....	22
11.12 Real time clock option.....	22
11.13 Safety and regulatory considerations.....	22
11.14 Tag reusability.....	22
<b>12 Tag location and presentation</b> .....	<b>22</b>
12.1 Material on which the tag is mounted or inserted.....	23

12.2	Geometry of the package/tag environment.....	23
12.3	Working environment.....	23
<b>13</b>	<b>Interrogator and reader requirements.....</b>	<b>23</b>
13.1	Safety and regulatory considerations.....	23
13.2	Data privacy.....	23
<b>14</b>	<b>Interoperability, compatibility and non-interference with other RF systems .....</b>	<b>23</b>
<b>Annex A</b>	<b>(informative) Returnable packaging items.....</b>	<b>24</b>
<b>Annex B</b>	<b>(normative) Encoding .....</b>	<b>33</b>
<b>Annex C</b>	<b>(informative) Table of useful data elements for product life cycle management.....</b>	<b>43</b>
<b>Bibliography</b>	<b>.....</b>	<b>45</b>

## Foreword

ISO (the International Organization for Standardization) is a worldwide federation of national standards bodies (ISO member bodies). The work of preparing International Standards is normally carried out through ISO technical committees. Each member body interested in a subject for which a technical committee has been established has the right to be represented on that committee. International organizations, governmental and non-governmental, in liaison with ISO, also take part in the work. ISO collaborates closely with the International Electrotechnical Commission (IEC) on all matters of electrotechnical standardization.

International Standards are drafted in accordance with the rules given in the ISO/IEC Directives, Part 2.

The main task of technical committees is to prepare International Standards. Draft International Standards adopted by the technical committees are circulated to the member bodies for voting. Publication as an International Standard requires approval by at least 75 % of the member bodies casting a vote.

Attention is drawn to the possibility that some of the elements of this document may be the subject of patent rights. ISO shall not be held responsible for identifying any or all such patent rights.

ISO 17364 was prepared by Technical Committee ISO/TC 122, *Packaging*.

This second edition cancels and replaces the first edition (17364:2009).

This International Standard has three annexes, two of which, A and B, provide normative information, and one which provides informative information.

## Introduction

The 'Supply Chain' is a multi-level concept that covers all aspects of taking a product from raw materials to a final product, including shipping to a final place of sale, use and maintenance, and potentially disposal. Each of these levels covers many aspects of dealing with products, and the business process for each level is both unique and overlapping with other levels.

This International Standard has been created in order to ensure compatibility at the physical, command and data levels with the four other International Standards under the general title: *Supply chain applications of RFID*. Where possible, this compatibility takes the form of interchangeability. Where interchangeability is not feasible, the International Standards within this suite are interoperable and non-interfering. The International Standards within the complete series of *Supply chain applications of RFID* include

- ISO 17363, *Supply chain applications of RFID — Freight containers*;
- ISO 17364, *Supply chain applications of RFID — Returnable transport items (RTIs) and returnable packaging items (RPis)*;
- ISO 17365, *Supply chain applications of RFID — Transport units*;
- ISO 17366, *Supply chain applications of RFID — Product packaging*;
- ISO 17367, *Supply chain applications of RFID — Product tagging*.

These International Standards define the technical aspects and data hierarchy of information required in each layer of the supply chain. The air-interface and communications protocol standards supported within these International Standards are ISO/IEC 18000 and ISO/IEC/IEEE 8802; commands and messages are specified by ISO/IEC 15961 and ISO/IEC 15962; semantics are defined in ISO/IEC 15418; syntax is defined in ISO/IEC 15434.

Although not pertinent to this International Standard, the following work is considered valuable:

- ISO/IEC JTC 1, *Information technology, SC 31, Automatic identification and data capture techniques*, in the areas of air interface, data semantic and syntax construction, and conformance standards;
- ISO/TC 104, *Freight containers*, in the area of freight container security, including electronic seals (e-seals) (i.e. ISO 18185) and container identification;
- ISO/TC 51, *Pallets for unit load method of materials handling*, in the area of associated terminology, pallet dimensions, design, and testing.

This International Standard defines the requirements for RFID tags for returnable transport items (RTIs). RTIs are defined as all means to assemble goods for transportation, storage, handling and product protection in the supply chain which are returned for further usage, including, for example, pallets with and without cash deposits as well as all forms of reusable crates, trays, boxes, roll pallets, barrels, trolleys, pallet collars and lids.

An important concept here is the use cases of such things as *unitized loads*, pallets and returnable transport items. How a pallet is used can determine whether it is covered under this International Standard as a *returnable transport item* or within ISO 17365 as a *transport unit*. If ownership title of the pallet remains with its owner (shipper) then this International Standard is applicable. If the ownership title of a pallet is transferred to the customer as part of a unitized load then it is considered an element of that unitized load, and the applicable International Standard is ISO 17365.

Additionally, this edition of 17364 introduces the concept of returnable packaging items (RPis). RPis are components of the RTI that must be tracked as well as the RTI itself as an asset of the owner/shipper. [Annex A](#) provides guidance on RPis.

Specific to RTIs is the placement of tagged packed products and products inside the RTI.



Owners and other users of RTIs can use this International Standard. It ensures the unambiguous and optimal use of RTIs in the supply chain. In conjunction with the complete series of these International Standards, a seamless application of the RTIs within the total supply chain is enabled.



# Supply chain applications of RFID — Returnable transport items (RTIs) and returnable packaging items (RPis)

## 1 Scope

This International Standard defines the basic features of RFID for use in the supply chain when applied to returnable transport items (RTIs). In particular it

- provides specifications for the identification of the RTI and the returnable packaging item (RPI),
- makes recommendations about additional information on the RF tag,
- specifies the semantics and data syntax to be used,
- specifies the data protocol to be used to interface with business applications and the RFID system,
- specifies the minimum performance requirements,
- specifies the air interface standards between the RF interrogator and RF tag, and
- specifies the reuse and recyclability of the RF tag.

## 2 Conformance and performance specifications

All of the devices and equipment that claim conformance with this International Standard shall also conform to the appropriate sections and parameters specified in ISO/IEC 18046 (all parts) for performance and ISO/IEC 18047-6 (for ISO/IEC 18000-63, Type C) and ISO/IEC 18047-3 (for the ASK interface of ISO/IEC 18000-3, Mode 3) for conformance.

When through trading-partner agreement, other specific ISO/IEC 18000 air interfaces are employed (i.e. ISO/IEC 18000-2, Type A and ISO/IEC 18000-7) the corresponding part of ISO/IEC 18047 shall be used.

## 3 Normative references

The following referenced documents are indispensable for the application of this document. For dated references, only the edition cited applies. For undated references, the latest edition of the referenced document (including any amendments) applies.

ISO 445, *Pallets for materials handling — Vocabulary*

ISO 830, *Freight containers — Vocabulary*

ISO 8601, *Data elements and interchange formats — Information interchange — Representation of dates and times*

ISO/IEC/IEEE 8802-15, 4, *Information technology — Telecommunications and information exchange between systems — Local and metropolitan area networks — Specific requirements — Part 15.4: Wireless medium access control (MAC) and physical layer (PHY) specifications for low-rate wireless personal area networks (WPANs)*

ISO/IEC 15418, *Information technology — Automatic identification and data capture techniques — GS1 Application Identifiers and ASC MH10 Data Identifiers and maintenance*

ISO/IEC 15434, *Information technology — Automatic identification and data capture techniques — Syntax for high-capacity ADC media*

ISO/IEC 15459-3, *Information technology — Automatic identification and data capture techniques — Unique identification — Part 3: Common rules*

ISO/IEC 15459-5, *Information technology — Automatic identification and data capture techniques — Unique identification — Part 5: Individual returnable transport items (RTIs)*

ISO/IEC 15961, *Information technology — Radio frequency identification (RFID) for item management — Data protocol: application interface*

ISO/IEC 15962:—<sup>1)</sup>, *Information technology — Radio frequency identification (RFID) for item management — Data protocol: data encoding rules and logical memory functions*

ISO/IEC 15963, *Information technology — Radio frequency identification for item management — Unique identification for RF tags*

ISO 17365, *Supply chain applications of RFID — Transport units*

ISO/IEC 18000-3, *Information technology — Radio frequency identification for item management — Part 3: Parameters for air interface communications at 13,56 MHz*

ISO/IEC 18000-63, *Information technology — Radio frequency identification for item management — Part 63: Parameters for air interface communications at 860 MHz to 960 MHz Type C*

ISO/IEC 18046 (all parts), *Information technology — Automatic identification and data capture techniques — Radio frequency identification device performance test methods*

ISO/IEC 18047-2, *Information technology — Radio frequency identification device conformance test methods — Part 2: Test methods for air interface communications below 135 kHz*

ISO/IEC 18047-3, *Information technology — Radio frequency identification device conformance test methods — Part 3: Test methods for air interface communications at 13,56 MHz*

ISO/IEC 18047-6, *Information technology — Radio frequency identification device conformance test methods — Part 6: Test methods for air interface communications at 860 MHz to 960 MHz*

ISO/IEC 18047-7, *Information technology — Radio frequency identification device conformance test methods — Part 7: Test methods for active air interface communications at 433 MHz*

ISO/IEC 19762 (all parts), *Information technology — Automatic identification and data capture (AIDC) techniques — Harmonized vocabulary*

ISO 21067, *Packaging — Vocabulary*

ISO/IEC/IEEE 21451-7, *Information technology — Smart transducer interface for sensors and actuators — Part 7: Transducer to radio frequency identification (RFID) systems communication protocols and Transducer Electronic Data Sheet (TEDS) formats*

ISO/IEC/TR 24729-1, *Information technology — Radio frequency identification for item management — Implementation guidelines — Part 1: RFID-enabled labels and packaging supporting ISO/IEC 18000-6C*

ANS MH10.8.2, *Data Identifiers and Application Identifiers*

GS1 EPC, *Tag Data Standard, Version 1.6*

GS1 *General Specifications*

ICNIRP Guidelines, *Guidelines for limiting exposure to time-varying electric, magnetic, and electromagnetic fields (up to 300 GHz)*

IEEE C95-1, *IEEE Standard for Safety Levels with Respect to Human Exposure to Radio Frequency Electromagnetic Fields, 3 kHz to 300 GHz*

---

1) To be published.

## 4 Terms and definitions

For the purposes of this document, the terms and definitions given in ISO 445, ISO 830, ISO/IEC 19762-1, ISO/IEC 19762-3, ISO 21067 and the following apply. For the purposes of this document, hexadecimal characters are represented as 0xnn, where “nn” is the hexadecimal value.

### 4.1

#### **product**

useable content of a package

Note 1 to entry: A special case exists where the usable content is not enclosed in any form of packaging.

### 4.2

#### **product package**

packaging, containing one or more products (same or different), together with any protective or other materials where required to ease handling, storage, transport, etc

Note 1 to entry: A product package may be an item packaged singularly, multiple quantities of the same item packaged together, or a group of parts packaged together.

Note 2 to entry: Adapted from ISO 22742:2010, definition 3.32.

### 4.3

#### **returnable transport item**

##### **RTI**

any product for the purposes of transport, handling and/or distribution of one or more products or product packages that are returned for further usage

**EXAMPLE** Pallets with and without cash deposits, as well as all forms of reusable crates, trays, boxes, roll pallets, barrels, and trolleys.

Note 1 to entry: The term “returnable transport item” implies that the ownership title of the item, e.g. pallet, remains with its owner (shipper), in which case this International Standard is applicable. If the ownership title of the item, e.g. pallet, is transferred to the customer as part of a unitized load then it is considered an element of that unitized load, and the applicable International Standard is ISO 17365.

Note 2 to entry: Freight containers, trailers and other similar enclosed modules are not covered by the term “returnable transport item”.

Note 3 to entry: The term “returnable transport equipment” is considered to have the same definition as the term “returnable transport item” within an electronic data interchange environment.

Note 4 to entry: Ownership does not change at time of purchase or delivery.

### 4.4

#### **freight container**

article of transport equipment which is

- a) of a permanent character and accordingly strong enough to be suitable for repeated use;
- b) specially designed to facilitate the carriage of goods by one or more modes of transport, without intermediate reloading;
- c) fitted with devices permitting its ready handling, particularly its transfer from one mode of transport to another;
- d) so designed as to be easy to fill and empty;
- e) having an internal volume of 1 m<sup>3</sup> (approximately 35,3 ft<sup>3</sup>)

[ISO 830:1999, definition 3.1]

**4.5  
packaging**

any material used for the containment, protection, handling, delivery, storage, transport and presentation of goods

Note 1 to entry: Ownership changes at time of purchase or delivery.

**4.6  
transport package  
transport packaging**

any material used for the purposes of transport, handling and/or distribution of one or more products or product packages

Note 1 to entry: Ownership changes at time of purchase or delivery.

**4.7  
transport unit**

transport packaging containing a single product/product package or collection of product/product packages (same or different) designed to enable these to be handled as a single transport entity

Note 1 to entry: Either a transport package or a unit load.

**4.8  
unitized**  
secured together so as to be handled as an entity

**4.9  
unit load**

one or more transport packages or other items held together by means such as pallet, slip sheet, strapping, interlocking, glue, shrink wrap, or net wrap, making them suitable for transport, stacking, and storage as a unit

**4.10  
returnable packaging item  
RPI**

any material used for the "protection" of goods during handling, delivery, storage and transport that are returned for further usage

Note 1 to entry: See [Annex A](#).

Note 2 to entry: Ownership does not change at time of purchase or delivery.

**4.11  
integrity**

designed such that any modification of the electronically stored information, without proper authorization, is not possible

**4.12  
ISO tag  
international unique identification tag**

ISO/IEC 18000-63, Type C or ISO/IEC 18000-3 Mode 3 tag with Protocol Control bit 17 set at "1" indicating that what follows is an Application Family Identifier (AFI)

**4.13  
EPC tag**

ISO/IEC 18000-63, Type C or ISO/IEC 18000-3 Mode 3 tag with Protocol Control bit 17 set at "0" indicating that what follows is an EPC header

**4.14  
monolithic memory structure**

memory storage that is addressable by a single addressing element

#### 4.15

##### **segmented memory structure**

memory storage that is separated into more than one element and requires multiple addressing elements for access

#### 4.16

##### **conveyable**

item that can be moved efficiently and safely on handling devices used to move material over a fixed line of travel

Note 1 to entry: For the purposes of this International Standard, such material handling devices or conveyors are considered to be continuous-loop belted systems moving packages or objects in a predetermined path and having fixed or selective points of loading or discharge. The width of the belt, height permitted within the facility, and weight capacity of the belt may determine whether the items are conveyable.

#### 4.17

##### **non-conveyable**

item of such width, height or mass to preclude its movement on conveyor systems

#### 4.18

##### **use case**

detailed description of a single activity in a business process that identifies data inputs and outputs, performance/timing requirements, the handling of error conditions and interfaces with external applications

## 5 Concepts

### 5.1 Differentiation between this layer and the preceding layers

[Figures 1](#) and [2](#) give a graphical representation of the supply chain. They show a conceptual model of possible supply chain relationships, not a one-for-one representation of physical things. Although several layers in [Figure 2](#) have clear physical counterparts, some common supply chain physical items fit in several layers depending on the use case. For example, a repetitively used pallet, under constant ownership, would be covered by this International Standard as an RTI; a pallet that is part of a consolidated unit load would be covered by ISO 17365 as a transport unit; and a pallet that is integral to a single item would be covered by ISO 17366 as product packaging.

The term “supply chain layers” is a multi-level concept that covers all aspects of taking a product from raw materials to a final product to shipping to a final place of sale, use, maintenance and potentially disposal and returned goods. Each of these levels covers many aspects of dealing with products and the business process for each level is both unique and overlapping with other levels.

The Item Level through to the Freight Container Level layers are addressed within the suite of standards for “supply chain applications of RFID” (see Introduction) and are intended to enhance supply chain visibility. The Movement Vehicle Level is the purview of ISO TC 204/WG 7.

The RTI Level in [Figure 2](#) and the RPIs (as defined in 4.10) are the subject of this International Standard.

RTI and RPI tags can be distinguished from other layer tags by use of a *group select* methodology contained in the RFID interrogator/reader. This group select function allows the interrogator and supporting automated information systems (AIS) to quickly identify RTI or RPI layer tags. As indicated in [5.2.2](#), the group select methodology is further elaborated in ISO/IEC 15961.

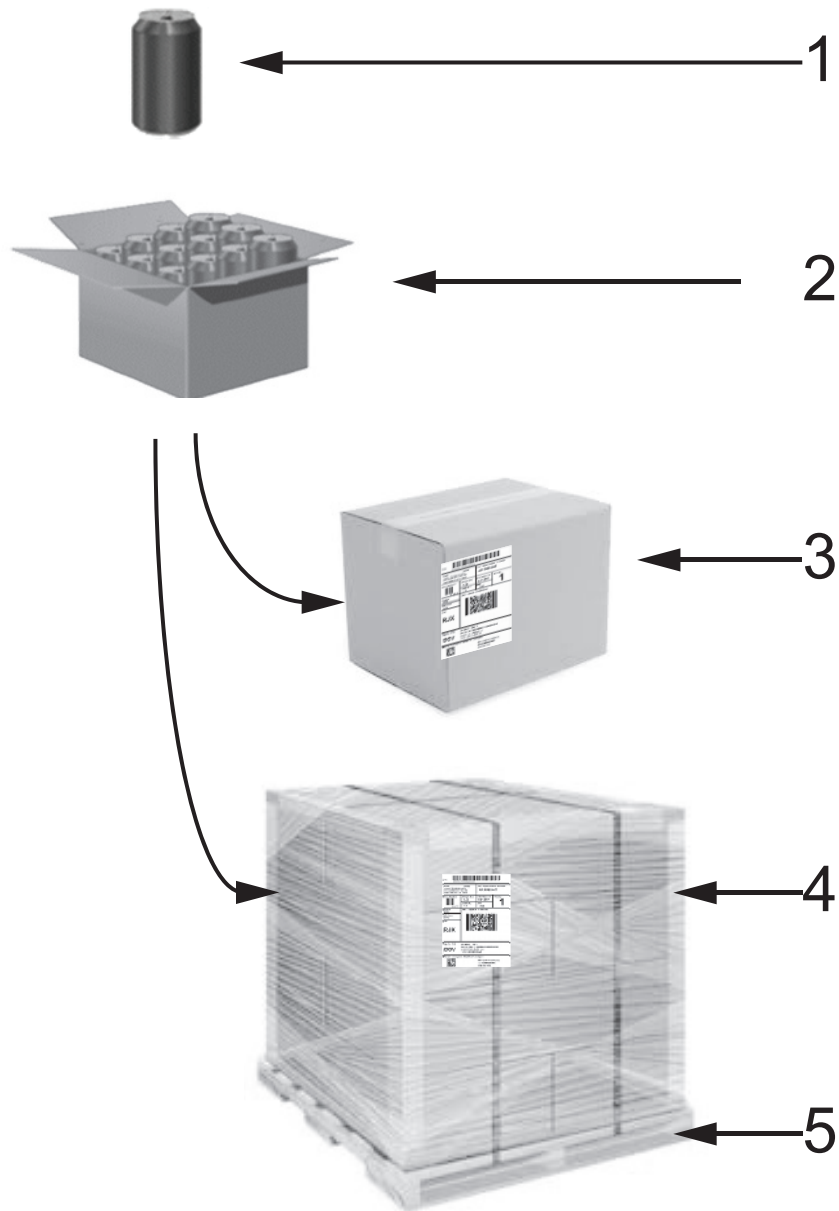

**Key**

- 1 primary packaging — consumer packaging — *(product)*
- 2 secondary packaging — outer packaging — *(product package)*
- 3 tertiary packaging — transport packaging — *(transport unit)*
- 4 tertiary packaging — unitized transport packaging — *(transport unit)*
- 5 pallet — *(returnable transport item — RTI)*

**Figure 1 — Packaging**



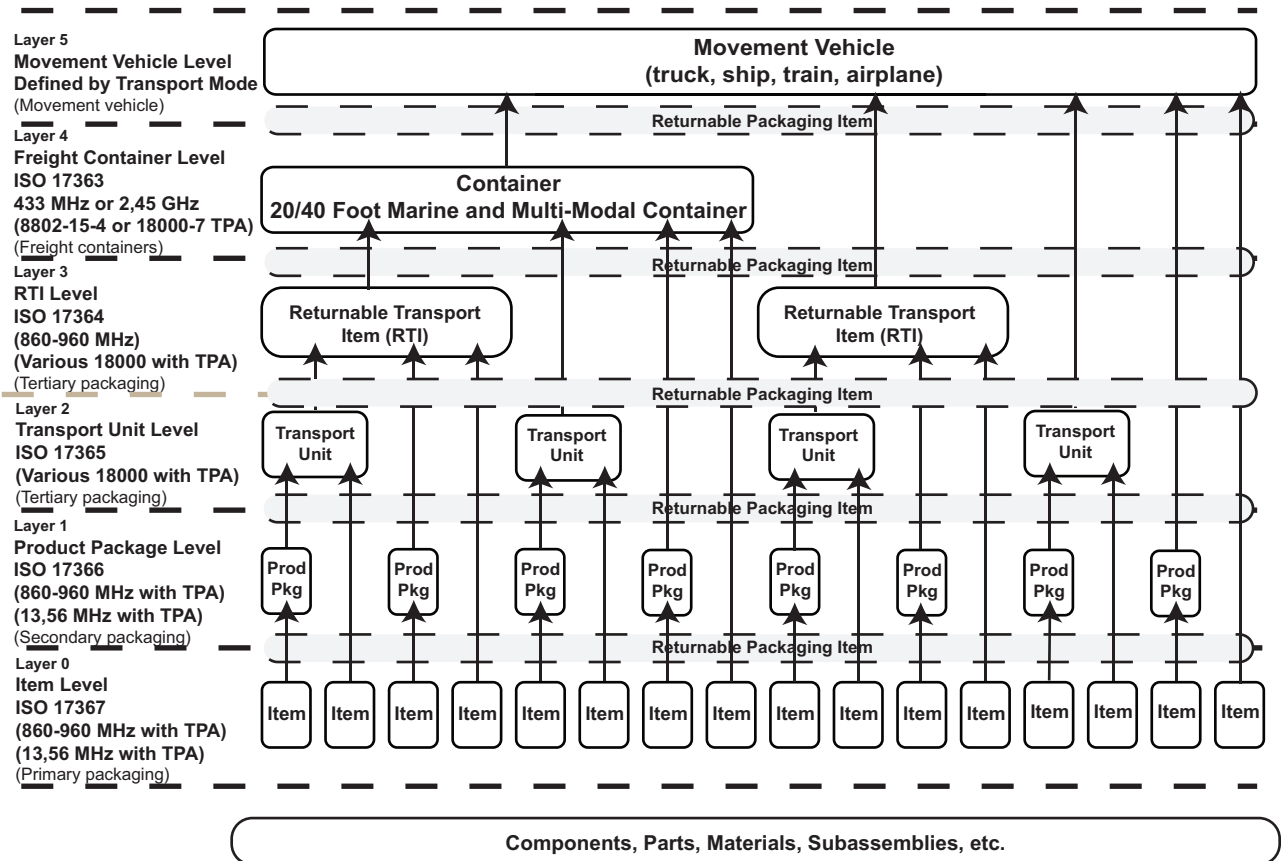

Figure 2 — Supply chain layers

## 5.2 Unique RTI and RPI identification

### 5.2.1 General

Unique RTI and RPI identification is a process that assigns a unique data string to an individual RTI or RPI, or in this case to an RFID tag that is associated to the RTI or RPI. The unique data string is called the unique RTI or RPI identifier. Unique item identification of RTIs or RPIs allows data collection and management at a granular level. The benefits of granular level data are evident in such areas as maintenance, warranties and enabling electronic transactions of record. This granularity is possible only if each tagged item has a unique item identifier.

The information on items in the supply chain is often held on computer systems and may be exchanged between parties involved via electronic data interchange (EDI) and extensible mark-up language (XML) schemas. The unique item identifier should be used as a key to access this information.

The unique RTI or RPI identifier described above shall be the unique identifier as described in ISO/IEC 15459-5. The unique item identifier (UII) provides granular discrimination between like items that are identified with RFID tags. The unique tag ID (as defined by ISO/IEC 15963) is a mechanism to uniquely identify RFID tags and is not the unique RTI identifier defined in this International Standard.

RTI or RPI tagging provides unique identification of RTIs or RPIs. The minimum data elements required for unique identification are an enterprise identifier/company identification number (CIN) and a serial number (SN) that is unique within that enterprise identifier.

This International Standard uses the following identification mechanisms for unique RTI or RPI identification:

- unique identifier for RTIs (ISO/IEC 15459-5;

— global returnable asset identifier (GRAI).

## 5.2.2 International unique identification of RTIs or RPIs

The unique identifier of ISO/IEC 15459 provides identification schemes for various layers of the supply chain, from layer 1 (products) up to layer 4 (returnable transport items). The unique identification of RTIs or RPIs shall use ISO/IEC 15459-5. Unique identification is provided by three components:

- a) issuing agency code (IAC),
- b) company identification number (CIN),
- c) serial number (SN),

preceded by an AFI and Data Identifier (DI). The AFI code assignments table in ISO/IEC 15961-3, Data Constructs Register and shown below in [Table 1](#) permits identification of the supply chain layer, i.e. product = 0xA1, transport unit = 0xA2, returnable transport item = 0xA3, and product package = 0xA5.

**Table 1 — 1736x AFI Assignments**

AFI	Assigned organization or function
0xA1	ISO 17367 product tagging
0xA2	ISO 17365 transport unit
0xA3	ISO 17364 returnable transport item or returnable packaging item
0xA4	ISO 17367 product tagging, containing hazardous materials
0xA5	ISO 17366 product packaging
0xA6	ISO 17366 product packaging, containing hazardous materials
0xA7	ISO 17365 transport unit, containing hazardous materials
0xA8	ISO 17364 returnable transport item or returnable packaging item, containing hazardous materials
0xA9	ISO 17363 freight containers
0xAA	ISO 17363 freight containers, containing hazardous materials

EPC does not use AFIs; consequently, there are no AFIs used for RTIs employed in retail applications using EPC. AFI 0xA3 may be used for RTIs intended solely for commodities other than consumer goods. [Annex B](#) provides an in-depth discussion of the ISO approach to encoding.

To define its class (in the ISO/IEC 15459 sense), the unique identifier shall have an associated class identifier, identified with the Data Identifier “25B”. [Clause 7](#) addresses data content for a unique identifier for returnable transport items. A unique identifier of returnable transport items should be no more than 35 alphanumeric characters in length, excluding the Data Identifier (an3+an..35). See [Table 2](#). With mutual agreement of the trading partners this length may be extended and shall be no more than 50 characters (an3+an..50). A unique identifier of returnable packaging items (55B) can be up to 50 alphanumeric characters in length, excluding the Data Identifier (an3+an..50). See [Table 3](#).

NOTE In view of current and future food safety legislation, differentiation between food and non-food applications could be beneficial, if not necessary. In particular, the risk analysis of cross-contamination would be addressed.

**Table 2 — ISO RTI Ull element string**

Format of the license plate	
Data Identifier	IAC, company identification number (CIN), serial number
25B	N <sub>1</sub> N <sub>2</sub> N <sub>3</sub> N <sub>4</sub> N <sub>5</sub> N <sub>6</sub> N <sub>7</sub> N <sub>8</sub> N <sub>9</sub> N <sub>10</sub> N <sub>11</sub> N <sub>12</sub> N <sub>13</sub> N <sub>14</sub> N <sub>15</sub> N <sub>16</sub> N <sub>17</sub> . . . N <sub>35</sub>

**Table 3 — ISO RPI Ull element string**

Format of the license plate	
Data Identifier	IAC, company identification number (CIN), serial number
55B	N <sub>1</sub> N <sub>2</sub> N <sub>3</sub> N <sub>4</sub> N <sub>5</sub> N <sub>6</sub> N <sub>7</sub> N <sub>8</sub> N <sub>9</sub> N <sub>10</sub> N <sub>11</sub> N <sub>12</sub> N <sub>13</sub> N <sub>14</sub> N <sub>15</sub> N <sub>16</sub> N <sub>17</sub> ... N <sub>35</sub>

### 5.2.3 Global returnable asset identifier (GRAI)

The global returnable asset identifier (GRAI) is a unique item identifier (UII) capable of providing unique item identification of RTIs.

The GRAI, as shown in [Table 4](#), consists of the following information elements:

The *Company Prefix*, assigned by GS1 to a managing entity. The Company Prefix is the same as the Company Prefix digits within a GS1 GRAI decimal code.

The *Asset Type*, assigned by the managing entity to a particular class of asset.

- The *Serial Number* assigned by the managing entity to an individual object. The EPC representation is only capable of representing a subset of Serial Numbers allowed in the GS1 General Specifications. Specifically, only those Serial Numbers consisting of one or more digits, with no leading zeros, are permitted.

**Table 4 — GRAI element string**

Format of the element string			
Application Identifier	Global returnable asset identifier		Serial Number
	GS1 Company Prefix / Asset Type	Check digit	
8003	0 N <sub>1</sub> N <sub>2</sub> N <sub>3</sub> N <sub>4</sub> N <sub>5</sub> N <sub>6</sub> N <sub>7</sub> N <sub>8</sub> N <sub>9</sub> N <sub>10</sub> N <sub>11</sub> N <sub>12</sub>	N <sub>13</sub>	X <sub>1</sub> variable X <sub>16</sub>

To define its class the unique item identifier shall have an associated class identifier, which is the Application Identifier 8003. [Clause 7](#) addresses data content for a GRAI.

## 5.3 Other identification requirements

This International Standard does not supersede or replace any applicable safety or regulatory marking or labelling requirements.

This International Standard is meant to satisfy the minimum RTI or RPI identification requirements of numerous applications and industry groups. As such, its applicability is to a wide range of industries, each of which may have specific implementation guidelines for this International Standard. This International Standard is to be applied in addition to any other mandated labelling requirements.

## 6 Differentiation within this layer

**6.1** The layer represented by RTIs and RPIs is characterized by the following unique aspects.

- The RTI/RPI may be used more than once.
- The same RTI/RPI can be used by different users and/or for different or multiple shipments at different moments.

The content of the RTI/RPI may consist of tagged (packed) products and/or non-tagged (packed) products.

- The RTI/RPI has a value of its own, not directly and necessarily derived from the product that it contains.

- The possibility to have selective access to the data elements stored and/or written into the RTI/RPI RF tag is required.
- The physical handling of the RTI/RPI includes specific steps, such as cleaning, storage, repair, maintenance and transport.

A typical RTI/RPI pool system can be described as follows:

- a) Manufacturer produces product.
- b) Primary packing is added; this can also be the RTI/RPI, for instance in the case of drums and bags for concentrated juices, water or beer.
- c) Packed products are packed in RTIs (multiple and different products can be included in one RTI). Small RTIs (crates, trays, boxes, barrels) are stored on large RTIs (pallet and/or roll container). Possibly protected/secured/covered by RPIs.
- d) RTIs are placed in transport vehicle (truck, boat, train, aeroplane) for direct transport to end user (mostly industrial) or regrouping in distribution centre (retail). Possibly protected/secured/covered by RPIs.
- e) RTIs/RPIs are redirected and can be (partially) emptied and refilled at distribution centre.
- f) RTIs/RPIs are unloaded and emptied at end-user site or retail outlet.
- g) Empty RTIs/RPIs are stored (nested, stacked) and collected by the (pool) owner or shipped back to the manufacturer of the packed product.
- h) Empty RTIs/RPIs are cleaned, stored, repaired and reprogrammed for new shipment of (packed) products.

**6.2** The relevant functions in RTI/RPI management and logistics are RTI/RPI supplier, dispatcher, receiver and service providers:

RTI/RPI suppliers own the RTI/RPI, control an RTI/RPI pool and make them available for use by dispatchers (RTI/RPI supplier and pool operator are used as synonymous terms).

- Dispatchers use RTIs/RPIs in the distribution of their goods. Dispatchers fill empty RTIs/RPIs with goods and hand over filled RTI/RPI to receivers. Dispatchers can be fillers, brand manufacturers, distribution centres, consolidation points, etc.
- Receivers receive RTIs/RPIs from dispatchers and make these items available for collection by service providers. Receivers can be retailers, distribution centres, consolidation points, etc.
- Service providers collect RTI/RPI from receiver and are responsible, in the case of items subject to a deposit, for refunding this deposit, and make the sorted RTI/RPI available to RTI/RPI suppliers or dispatchers.

**6.3** A company can fulfil more than one of these functions, for example:

- a beverage producer can use his own crates for bottles; in this case the producer acts as an RTI/RPI supplier and a dispatcher;
- a retail distribution centre (RDC) sends received units to its outlets; in this case the RDC acts as a receiver as well as a dispatcher;
- an RDC can sort and collect empty crates after use; in this case the RDC acts as a receiver and a service provider;
- a pool operator collects and sorts empty crates; in this case the pool operator acts as an RTI/RPI supplier and a service provider.

**6.4** Business processes such as those described below are illustrative of the applications envisioned by this International Standard.

- Receipt: receiving goods/empty or filled RTI/RPI/unit loads for further use, e.g. transshipment, storage, selling, recording of data, collecting, sorting or reconditioning.
- Unloading: physical movement of unit loads out of a means of transport.
- Identification: systematic determination and registration (including measuring) of objects following this International Standard for numbering systems in order to distinguish them from each other. This includes the possibility of electronic identification (scanning).
- Inspection: checking completeness of goods/empty or filled RTI/RPI/unit loads; checking if goods/empty or filled RTI/unit loads fulfil specific and defined criteria for quality.
- Order picking: assembling goods to unit loads according to order (list).
- Retaining: means (e.g. straps) to guarantee safe unit loads during transport.
- Loading: physical movement of unit loads into a means of transport.
- Storage: maintaining stocks of products/empty or filled RTI/RPI/unit loads in a warehouse, including internal movement activities.
- Transshipment/cross docking: transferring goods/empty or filled RTI/RPI/unit loads from one means of transport to another during the course of one transport operation according to order.
- Dispatching: shipping of goods/empty or filled RTI/RPI/unit loads, including recording of data.
- Labelling: putting on labels/writing on tags following the recommendations of GS1, covering e.g. logistic data.
- Transport: movement of goods/empty or filled RTI/RPI/unit loads by means of transport from point-to-point.
- Warehousing: all activities of receiving, holding, handling and dispatching goods/empty or filled RTI/RPI/unit loads in a store.
- Collecting: retrieving goods/empty RTI/RPI from a location according to order, including recording of data (reverse logistics).
- Sorting: separating different kinds of RTI/RPI and making them available for further activities, including recording of data.
- Reconditioning: all physical activities that enable RTI/RPI to be reused, e.g. repairing, washing.

Different business processes within the supply chain will employ distinctly different groupings of functions and processes outlined above. The reading, writing or erasing of data to/from a tag is intended to effect identification and data capture about the product and the process involved, and shall be integrated into business processes as required by the business process owner.

The RTI and the system in which it is used are closely intertwined. Additionally, all variations possible in different supply chains are also observed in the RTI layer of the supply chain due to the nature of the RTI and its usage.

## **7 Data content**

### **7.1 Introduction**

Subclauses 7.2 to 7.8 describe the data content of RFID tags for the RTI layer. They identify, amongst others,

- the data elements that shall or may be present on the tag,

- the way in which the data elements are identified (semantics),
- the representation of data elements in tag memory, and
- the placement of data elements in the memory of the tag.

NOTE 1 As specified elsewhere in this International Standard, use is made of ISO/IEC 18000-63, Type C, and ISO/IEC 18000-3, Mode 3 tags. Where necessary, use is made of the specific (memory) terminology of those tags.

NOTE 2 For the purpose of RTI tagging, only read/write tags are used. This is done to enable RTI pool owners to assign specific and permanent UIIs to their RTIs.

## 7.2 System data elements

### 7.2.1 Unique RTI/RPI identification

The first data element on a compliant tag shall be the unique identification described in ISO/IEC 15459-5. The length and nature of this unique identification is defined in this data element. For an ISO/IEC 18000-63, Type C compliant tag, the unique identification data element is segregated from any additional (User Data) by the memory architecture. The unique identification data element shall be stored in UII memory (Bank 01), with any additional data being stored in user memory (Bank 11). A unique identifier of returnable transport items can be up to 35 alphanumeric characters in length, excluding the Data Identifier (an3+an..35). With the mutual agreement of the trading partners this length can be extended to 50 characters (an3+an..50). A unique identifier of returnable packaging items can be up to 50 alphanumeric characters in length, excluding the Data Identifier (an3+an..50). [Annex B](#) provides an in-depth analysis of encoding.

### 7.2.2 Data semantics

Tags that only encode the unique RTI identity should conform to ISO/IEC 15961. This data structure shall conform to [Annex B](#). Tags containing complex data structures or larger data sets shall include semantics that conform to ISO/IEC 15418 and [Annex B](#) of this International Standard.

### 7.2.3 Data syntax

Tags that only encode identity are considered to have no syntax. Tags containing complex data structures or larger data sets shall conform to [Annex B](#) of this International Standard.

### 7.2.4 Tag character set

Tags using Data Identifiers shall employ characters from the character set 0, 1, 2, 3, 4, 5, 6, 7, 8, 9, A, B, C, D, E, F, G, H, I, J, K, L, M, N, O, P, Q, R, S, T, U, V, W, X, Y, Z, [, \, ], ;, :, <, =, >, ?, @, (, ), \*, +, -, ., /, <GS>, <RS>, <FS>, <US>, <EOT>, and Space, as shown in Table B.1.

## 7.3 Tag structure

### 7.3.1 Tag header

Tag headers shall contain either an ISO/IEC defined AFI or an EPC defined Attribute bits. The ISO/IEC 15961, AFI for returnable transport items is 0xA3, in bits 0x18 – 0x1F as described in [Tables 1](#) and [5](#). Support for ISO standards (including AFIs) is indicated when bit 0x17 is set to “1”. Alternatively, such headers may contain an EPC header as described in the GS1 EPC Tag Data Standard. Support for EPC coding is indicated when bit 0x17 is set to “0”.

NOTE A 96-bit GRAI is represented by EPC header 0x33.

### 7.3.2 Tag memory

Figure 3 provides a graphical representation of tag memory.

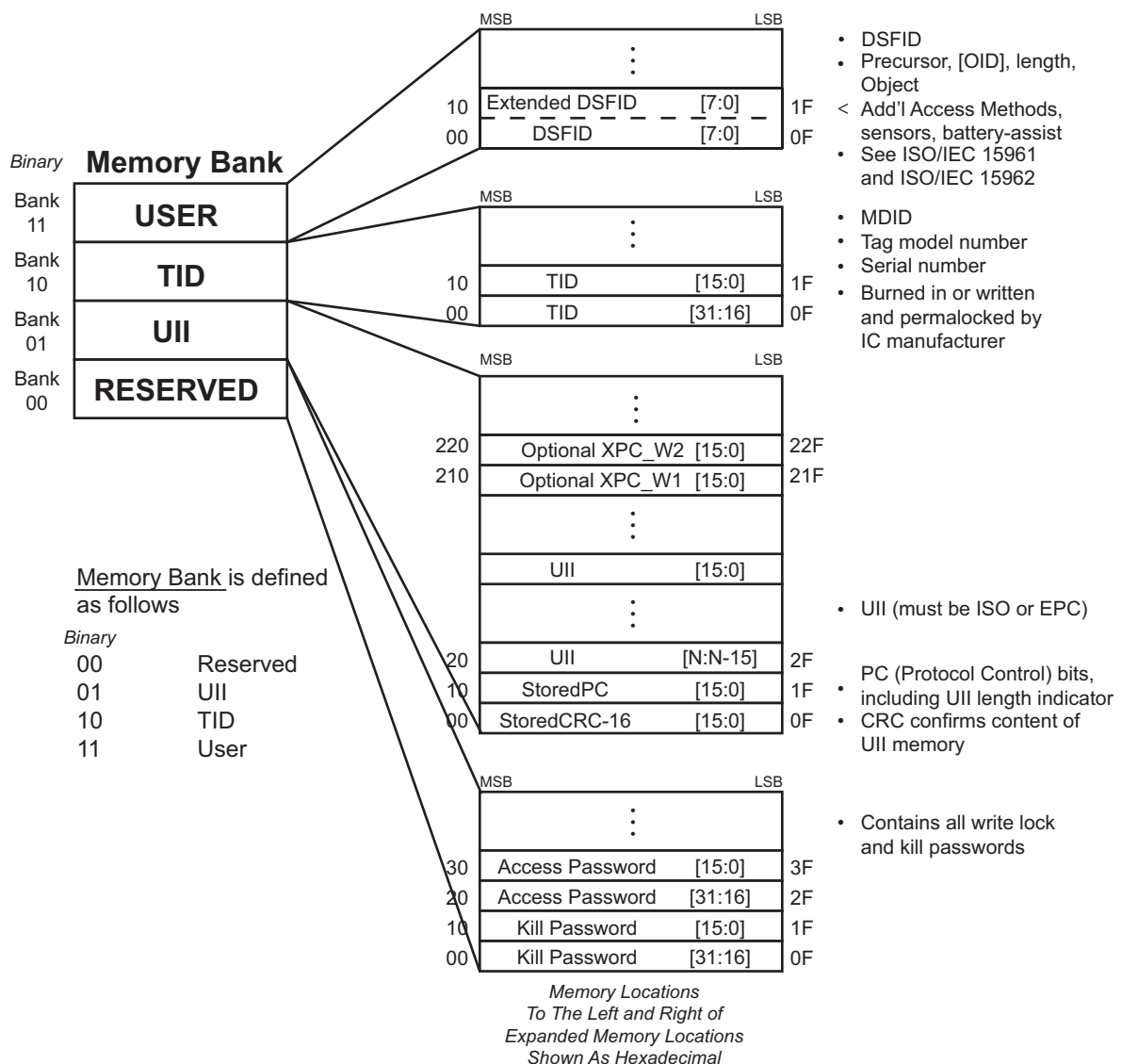

Figure 3 — Segmented memory map

### 7.3.3 Tag memory banks

Tag memory shall be logically separated into four distinct banks, each of which may comprise one or more memory words. A logical memory map is given in Figure 3. The memory banks are as follows.

- Reserved memory (MB00): shall contain the kill and access passwords. The kill password shall be stored at memory addresses 0x00 to 0x1F; the access password shall be stored at memory addresses 0x20 to 0x3F. If a tag does not implement the kill and/or access password(s), the tag shall act as though it had zero-valued password(s) that are permanently read/write locked, and the corresponding memory locations in reserved memory need not exist.
- UII memory (MB01): shall contain a CRC-16 at memory addresses 0x00 to 0x0F, Protocol-Control (PC) bits at memory addresses 0x10 to 0x1F, and a code, i.e. a UII, that identifies the object to which the tag is or will be attached beginning at address 0x20. The PC is subdivided into a UII length field in memory locations 0x10 to 0x14, an indication of user memory bit in memory location 0x15, a PC extension indicator bit in memory location 0x16, an ISO/EPC bit in memory location 0x17, and

Attribute bits in memory locations 0x18 to 0x1F. The CRC-16, PC, and UII shall be stored MSB first (the UII's MSB is stored in location 0x20).

- c) TID memory (MB10): shall contain an 8-bit ISO/IEC 15963 allocation class identifier at memory locations 0x00 to 0x07. TID memory shall contain sufficient identifying information above 0x07 for an Interrogator to uniquely identify the custom commands and/or optional features that a tag supports.

For EPC tags whose ISO/IEC 15963-allocation class identifier is 11100010<sub>2</sub> (0xE2), this identifying information shall comprise a 12-bit tag mask-designer identifier at memory locations 0x08 to 0x13 and a 12-bit tag model number at memory locations 0x14 to 0x1F. Tags may contain tag- and vendor-specific data (for example, a tag serial number) in TID memory above 0x1F.

For ISO/IEC 15459-5 tags operating conformant to ISO/IEC 18000-63, Type C and whose ISO/IEC 15963 allocation class identifier is 11100000<sub>2</sub> (0xE0), this identifying information shall comprise an 8-bit IC manufacturer registration number at memory locations 0x08 to 0x0F and a 48-bit serial number allocated by the IC manufacturer from memory locations 0x10 to 0x3F.

For ISO/IEC 15459-5 tags operating conformant to ISO/IEC 18000-3, Mode 3 and whose ISO/IEC 15963 allocation class identifier is 11100000<sub>2</sub> (0xE0), this identifying information shall comprise an 8-bit IC manufacturer registration number at memory locations 0x08 to 0x0F and a 48-bit serial number allocated by the IC manufacturer from memory locations 0x10 to 0x3F.

For ISO/IEC 15459-5 tags operating conformant to ISO/IEC 18000-63, Type C or ISO/IEC 18000-3, Mode 3 and whose ISO/IEC 15963 allocation class identifier is 11100011<sub>2</sub> (0xE3), this identifying information shall comprise an 8-bit IC manufacturer registration number at memory locations 0x08 to 0x0F, a 16-bit user memory and size definition according to ISO/IEC 15963 from memory locations 0x10 to 0x1F, and a 48-bit serial number allocated by the IC manufacturer from memory locations 0x20 to 0x4F.

For ISO/IEC 15459-5 tags operating conformant to ISO/IEC 18000-7 and whose ISO/IEC 15963 allocation class identifier is 00010001<sub>2</sub> (0x11), this identifying information shall comprise an 8-bit tag mask-designer identifier at memory locations 0x08 to 0x0F and a 32-bit tag serial number at memory locations 0x16 to 0x1F.

For ISO/IEC 15459-5 tags operating conformant to ISO/IEC 18000-2, Type A and whose ISO/IEC 15963 allocation class identifier is 11100000<sub>2</sub> (0xE0), this identifying information shall comprise an 8-bit tag manufacturer identification at memory locations 0x08 to 0x15 and a 48-bit tag serial number at memory locations 0x16 to 0x3F.

- d) User memory (MB11): allows user-specific data storage. The storage format described in ISO/IEC 15961 and ISO/IEC 15962 defines the memory organization. The presence of data in user memory in MB11 shall be indicated by the presence of a "1" in the 0x15 PC bit. A zero in the 0x15 PC bit shall indicate that there is no user memory at MB11 or that there is no data in MB11. Further information on MB11 can be found in [Annex B](#).

## 7.4 Protocol control (PC) bits

The PC bits contain physical-layer information that a tag backscatters with its UII during an inventory operation. There are 16 PC bits, stored in UII memory at addresses 0x10 to 0x1F, with bit values defined as follows:

- Bits 0x10 to 0x14: The length of the (PC + UII) that a tag backscatters, in words:
  - 00000<sub>2</sub>: one word (addresses 0x10 to 0x1F in UII memory).
  - 00001<sub>2</sub>: two words (addresses 0x10 to 0x2F in UII memory).
  - 00010<sub>2</sub>: three words (addresses 0x10 to 0x3F in UII memory).



- 11111<sub>2</sub>: 32 words (addresses 0x10 to 0x20F in UII memory).
- Bit 0x15: User Memory; shall be set to “0” for tags without data in user memory (MB “11”) or tags without User Memory and shall be set to “1” for tags with data in user memory.
- Bit 0x16: Shall be set to “0” if there is no extension of the PC bits and shall be set to “1” if the PC bits are extended by an additional 16 bits.

NOTE 1 If a tag implements XPC bits then PC bit 0x16 shall be the logical OR of the XPC bits contents. The tag computes this logical OR, and maps the result into PC bit 0x16, at power up. Readers can select on this bit, and tags will backscatter it.

NOTE 2 The XPC will be logically located at word 32 of UII memory. If a reader wants to select on the XPC bits, then it issues a Select command targeting this memory location.

- Bit 0x17: Shall be set to “0” if encoding an EPC and shall be set to “1” if encoding an ISO/IEC 15961, AFI in Bits 0x18 – 0x1F.
- Bits 0x18 – 0x1F: A numbering system identifier Attribute bits whose default value is 00000000<sub>2</sub> and which may include an AFI as defined in ISO/IEC 15961 (when encoding the tag pursuant to ISO standards). The MSB of the Attribute bits is stored in memory location 0x18. Bit 0x1F has been designated within the GS1 EPC system to be used as an indicator that the RTI contains Hazardous Materials.

The default (unprogrammed) PC value shall be 0x0000. [Table 5](#) summarizes the content.

**Table 5 — Segmented memory — Memory bank “01”**

Protocol Control bits run from 0x10 to 0x1F															
10	11	12	13	14	0/1 15	0/1 16	0/1 17	18	19	1A	1B	1C	1D	1E	1F
Length indicator					User memory	XPC bit	EPC/ISO bit = 1	ISO Application family identifier (AFI)							
Length indicator					User memory	XPC bit	EPC/ISO bit = 0	EPC Attribute bits							Haz Mat

## 7.5 Data elements

### 7.5.1 Unique RTI/RPI identifier

The UII–RTI shall be present on all conformant RTI tags. For non-retail tags, the unique RTI identifier shall conform to ISO/IEC 15459-5 and shall be used as described in [5.2.2](#). For retail tags, the unique RTI identifier shall conform to GS1 EPC, *Tag Data Standard*, Version 1.6 for the GRAI-96 and shall be used as described in [5.2.2](#).

One tag represents the unique RTI identification and the second represents the shipment unique identification. Shipment unique identification is addressed at length in ISO 17365.

For full read/write tags, additional tag data shall include the appropriate ISO/IEC 15459-5 unique identifier. The mandatory data to be written to the tag shall be a function of the type of tag and the purpose of the specific tag application. For the purposes of this International Standard, the only required data element in compliant tags is the UII–RTI identifier, however, for practical purposes, both the UII–RTI and the UII–Transport Unit Identifier would be encoded using ISO/IEC 15961, the syntax of ISO/IEC 15434 and the semantics of ISO/IEC 15418 and ISO/IEC 15962.

The UII–RTI shall be locked, under password protection.

## 7.5.2 Hazardous goods

RFID tags for items that are classified as hazardous for storage, transportation or use shall contain a bit reference indicating that the item is hazardous. In addition, the tag, regulations and statutes may require a more detailed categorization of the hazard. The setting of this bit ("1") directs the material handler to the included material safety data sheet. This additional categorization shall not be mandatory unless it provides an approved replacement for hazard data otherwise required by the requiring authority.

The specific hazardous goods code shall include the appropriate Data Identifier and qualifier and shall be reflected in the user data memory. The presence of hazardous material for EPC RTIs is indicated by bit "1F" of memory bank MB01 as defined in ISO/IEC 18000-63, Type C and ISO/IEC 18000-3 Mode 3. The presence of hazardous material for ISO RTIs is indicated by the AFI "0xA8" in bits "0x18" to "0x1F" of memory bank MB01 as defined in ISO/IEC 18000-63, Type C and ISO/IEC 18000-3 Mode 3.

This International Standard does not supersede or replace any applicable safety or regulatory marking or labelling requirements. This International Standard is meant to satisfy the minimum RTI identification requirements of numerous applications and industry groups. As such, it is applicable to a wide range of industries, each of which may have specific implementation guidelines for this International Standard. This International Standard is to be applied in addition to any other mandated labelling requirements.

## 7.5.3 Optional data

Depending on the tag type and capacity, optional data may be written to tags as required. Agreement between trading partners is not required. Optional data may be encrypted or otherwise secured at the discretion of the tag writer. The semantics of other user data shall conform to [Annex B](#). The syntax of other user data shall conform to [Annex B](#). ISO 15394 provides specific examples of other data elements using the ISO/IEC 15418 semantics and the ISO/IEC 15434 syntax.

## 7.6 Traceability

Unique identification enables traceability. Traceability can relate to specific items yielding the ability to differentiate between like items; it can also relate to groups of like items differentiating them from unlike items.

Serialization schemes shall comply with ISO/IEC 15459-5.

## 7.7 Combined RTI/RPI and transport unit data

### 7.7.1 General

RFID tags are available in different formats. There are read only, write once/read many (WORM) and full read/write. All tags shall have the tag ID written to them by the manufacturers in accordance with ISO/IEC 15963 and locked. If read only or WORM tags are employed, two tags shall be used. One tag represents the unique transport unit identifier and the second represents the unique RTI. Unique transport unit identification shall be as addressed at length in ISO 17365.

### 7.7.2 ISO data structures

Where there are application requirements to encode both the identity of the asset (this International Standard) as well as a shipment ID or license plate (ISO 17365), it is possible to encode these unique identities in either one or two RF tags. In the case of two tags within the ISO system, each tag would include its own unique AFI, that is, "0xA2" for license plate (shipment identification) and "0xA3" for the RTI AFI. The AFIs shall be followed by the respective ASC MH10 Data Identifier as specified in ISO/IEC 15418. In the case of the RTI, that DI is "25B" and in the case of an RPI, that DI is "55B". In the case of the transport unit, that DI is the appropriate "J" Data Identifier.

When encoding both data structures in a single tag that has a monolithic memory structure (e.g. ISO/IEC 18000-2, Type A), the first data structure shall be the UII-RTI, preceded by the DI "25B" and

shall be locked, and the second data structure shall be the UII–transport unit that will change with each trip of the RTI, preceded by the “J” DI.

For tags having a segmented memory structure (e.g. ISO/IEC 18000-63, Type C and ISO/IEC 18000-3 Mode 3), the UII–RTI shall be written to the UII memory and locked. The UII–transport unit (ISO 17365) shall be preceded by the “J” DI and, along with any additional data (with the appropriate DI), be written and locked in user memory. When combining multiple data structures, the syntax of the data shall comply with ISO/IEC 15434. For ISO/IEC 18000-7 tags, the memory segmentation will be as described in that International Standard.

### **7.7.3 GS1 EPC data structures**

Where there are application requirements to encode both the identity of the asset (GRAI) as well as a unique pointer to a database, e.g. shipment ID or GS1 Serialized Shipping Container Code (SSCC), it is possible to encode these unique identities in either one or two RF tags. In the case of two tags within the EPC system, each tag would include its own unique header, that is, “31” for SSCC and “33” for GRAI. In the case of encoding both data structures in a single tag, the first data structure (96 bits) shall be the GRAI and shall be locked, and the second data structure (96 bits) shall be the SSCC that will change with each trip of the RTI. Since both data fields are fixed length, there is no requirement for a data element separator.

GS1 Member Organizations allocate the GS1 Company Prefix to a system user (see GS1 *General Specifications*). This makes the SSCC unique worldwide but does not identify the origin of the unit.

## **7.8 Unique item serialization**

Unique item identification shall be assured by concatenating three elements of data: the issuing agency code (IAC), an enterprise identifier (relating to the IAC) and a unique serialization as described in ISO/IEC 15459-5 using the rules of ISO/IEC 15459-3.

RTI-RFID tag data formats shall make a clear distinction in the leading eight bits of the tag between unique RTI identification and its contents, in addition to a ninth bit (at the 17<sup>th</sup> position in [Table 5](#)) indicating ISO (AFI) or EPC.

The data structure identifying the asset shall be locked. This information shall only be changed in the case of change of ownership. For tags having a monolithic memory structure, the data structure identifying the shipment shall be appended to the asset license plate and shall be rewritable for new shipments.

For tags having a segmented memory structure, the asset license plate shall be stored in the memory segment dedicated to the item license plate (i.e. UII memory). The data structure identifying the shipment shall be stored in the memory segment dedicated to additional data (i.e. user memory) and shall be rewritable.

## **8 Data security**

### **8.1 Confidentiality**

Tag users wanting to have their tags read only by authorized users shall be able to secure/protect data written to a tag. The tag shall be capable of having secured/protected data written to it and read from it without interference from the tag design or structure. Use of this feature shall be at the discretion of the user.

### **8.2 Data integrity**

Tags shall be able to prevent the alteration or erasure of data commonly known as *Locking* data. Locking of data shall be at the discretion of the user, except for Tag ID (MB10), which shall be serialized and locked by the manufacturer. A CRC-16 is required to enhance the integrity of the data. The location of the stored CRC-16 shall be as per the memory map in [Figure 3](#).

### 8.3 Data preservation

For an RTI in the supply chain, it shall be impossible at the point-of-sale of any (packed) product to disable the tag, e.g. by a kill-command. The rationale for not killing the tag is that the RTI does not change ownership to the consumer and it is highly unlikely that the privacy of the individual will be affected by data from an RTI.

### 8.4 Interrogator authentication

A tag's data storage and transfer protocols shall provide for the user-enabled option to require authentication of the interrogator's authorization prior to reading the tag data.

### 8.5 Non-repudiation/audit trail

Tags shall be capable of supporting non-repudiation when programmed to provide non-forgable evidence that a specific action occurred.

## 9 Identification of RFID labelled material

RTIs, RF tags and RF label inlays compliant with this International Standard shall include one or more of the internationally accepted RFID emblems. The accepted emblems given in [Figure 4](#) are examples of the RFID emblem and EPC seal as described in ISO/IEC 29160.



NOTE 1 The above emblems only represent the 860 MHz to 960 MHz air interface for this application standard. Other air interface designations can be found in ISO/IEC 29160.

NOTE 2 These graphics can be scaled to the appropriate size and are available in either dark-on-light or light-on-dark.

**Figure 4 — ISO and EPC RFID compliance emblems**

## 10 Human readable information

### 10.1 Human readable interpretation

Human readable interpretation is the literal representation of all of the data on the tag, including semantics. When human readable interpretation is used, it shall be placed on the exterior of the RTI, as required elsewhere in this section. Where used, the mandatory information (UII) contained in the binary encodings in RF tags shall be represented in their octal or hexadecimal equivalent as specified in ISO/IEC/TR 24729-1. ISO standard two-dimensional symbols, for example QR Code, Data Matrix ECC 200 or PDF417, encoded in conformance with ISO/IEC 15418 and ISO/IEC 15434, should be considered as a primary backup to RF tags on RTIs. An additional level of backup of human readable interpretation may be considered.

ISO/IEC/TR 24729-1 shows how to encode within a 2D symbol everything that is in an RF tag. What is most likely needed, however, is to encode the same data in a 2D symbol and RF tag, so that a host

computer receives the same information, regardless of media. This is accomplished by the means contained in [Annex B](#).

Human readable interpretation of the data on an RTI RFID tag is optional, except when required by regulation or statute.

## 10.2 Human readable translation

Human readable translation of the data on the tag is selected data rather than complete data and may or may not contain data semantics. Human readable translation should be used when space constraints or privacy considerations do not permit the use of human readable interpretation.

HRI of either ISO UII or EPC tags shall be the upper case alphabetic and numeric representation of the encoded data as set forth in ISO/IEC/TR 24729-1 and [Annex B](#).

## 10.3 Data titles

The use of data titles shall be as specified in ANS MH10.8.2 or in GS1 *General Specifications*.

## 10.4 Backup

Use of human readable information, either “interpretation” or “translation”, is required for data that is critical to the item’s use and shall function as the first backup in the event that the RFID tag is unreadable/misleading for any reason. If optically readable media is used, trading partners shall agree upon a linear symbol such as Code 128, as described in ISO/IEC 15417, or a two-dimensional symbol such as Data Matrix, as described in ISO/IEC 16022 or QR Code, as described in ISO/IEC 18004.

If optically readable media is used, the International Standards shown in [Figure 5](#) shall be used.

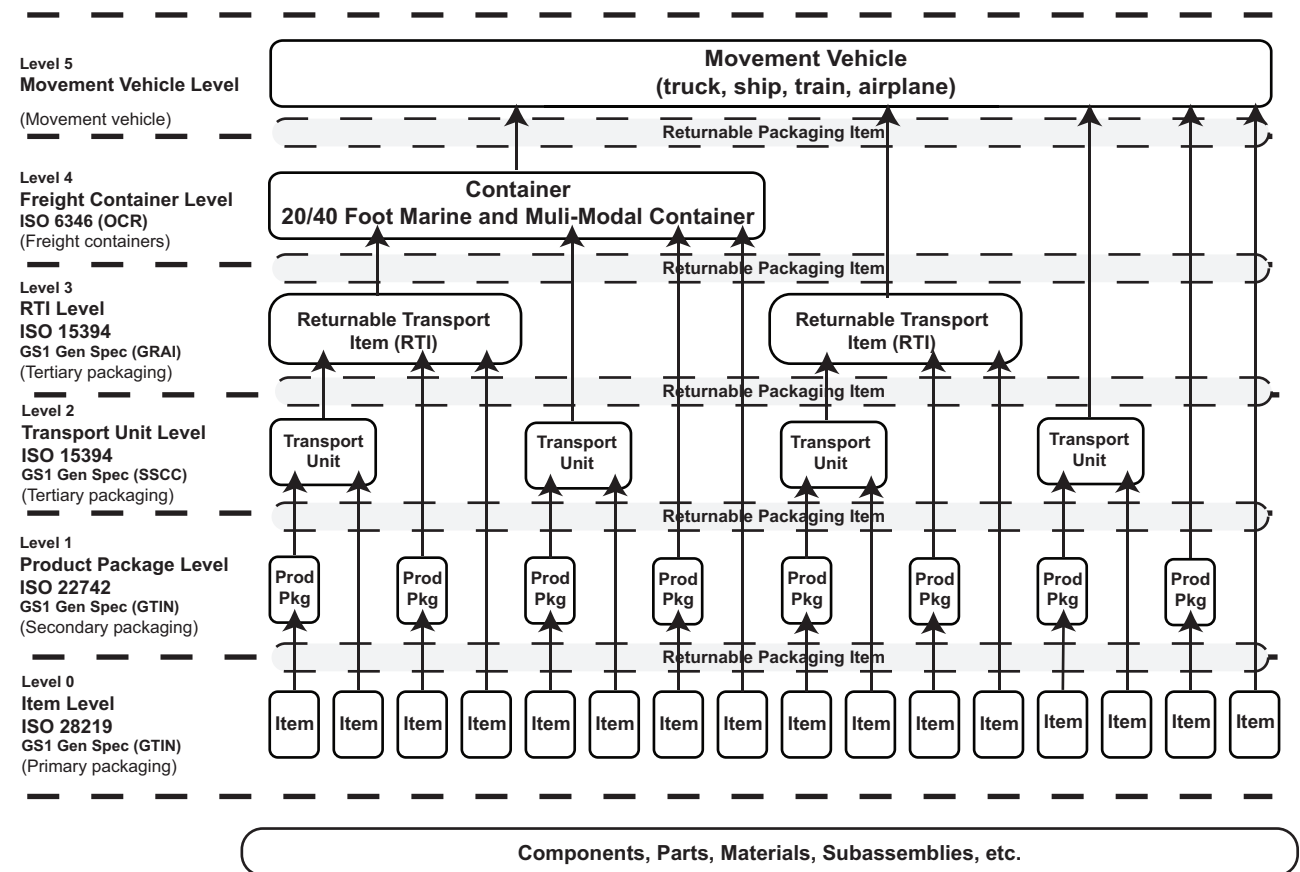

Figure 5 — Supply chain standards for bar codes and two-dimensional symbols

## 11 Tag operation

### 11.1 Data protocol

The data protocol for this International Standard shall support the requirements of [Annex B](#).

### 11.2 Minimum performance requirements (range and rate)

The performance for tags shall be measured in accordance with ISO/IEC 18046-3. Minimum performance requirements will vary for different functional applications of RFID. [Table 6](#) shows the typical performance requirements for passive tags to transfer tag data of 256 bits. These specifications also relate to the writing of the tag. Greater distances can be achieved in reading from RF tags than writing to RF tags.<sup>2)</sup> The performance for interrogator shall be measured in accordance with ISO/IEC 18046-2. The performance for systems shall be measured in accordance with ISO/IEC 18046-1.

**Table 6 — Typical tag performance**

Parameter	860 MHz to 960 MHz ISO/IEC 18000-63, Type C	13,56 MHz ISO/IEC 18000-3, Mode 3	<135 kHz ISO/IEC 18000-2, Type A	433,92 MHz ISO/IEC 18000-7
How far? [Minimum supported read distance (in metres)]	3	0,7	0,7	30
How fast? [Minimum supported item speed when read (in kilometres per hour)]	16	16	0	16
How many? [Minimum supported effective measure of tag data transfer rate and ability to do anti-collision (in tags per second)]	200 <sup>a</sup> or 500 <sup>b</sup>	200	1	1
<sup>a</sup> This value corresponds to the 200 kHz bandwidth.				
<sup>b</sup> This value corresponds to the 500 kHz bandwidth.				

### 11.3 Environmental parameters

The operating environment will vary significantly by location. A description of various environmental factors associated with RFID can be found in ISO/IEC/TR 18001. Consideration will be given to the following general parameter set, as derived from the RTI user community.

- The RTI RFID tag shall function properly in the temperature range  $-40\text{ }^{\circ}\text{C}$  to  $+70\text{ }^{\circ}\text{C}$  and be able to endure, for a specified period of time, harsher conditions in the range  $-50\text{ }^{\circ}\text{C}$  to  $+85\text{ }^{\circ}\text{C}$ .
- An operating environment with relative humidity of 95 %.
- Warehouse construction, including racking.
- Transportation mode.
- Speed and direction of movement of tag relative to reader.
- Orientation of tag to reader (i.e. controlled or random).
- Read distance.
- Write distance (if applicable).

2) ) In case regulatory restrictions provide fewer channels than there are interrogators in the environment, this performance can only be achieved by appropriate shielding of the interrogators against other interrogators.

- Electromagnetic interference from motors, fluorescent lights and other spectrum users.
- Electromagnetic characteristics of the packaging and contents of the tagged item.
- Shape and size constraints on antenna, and any requirement to decouple antenna from tagged item.
- Form factor constraints in terms of size, shape, resistance to pressure, temperature, moisture, cleaning and contaminants [dust, oil (natural food, petroleum and synthetic), acids and alkalis].
- Method of attachment of form factor.
- Resistance of readers to heat, moisture, impact damage.
- Health and safety regulations.

Operational parameters for RTIs strongly depend on the type of (packed) products in the RTI and the type of supply chain (industrial or consumer, high value or high volume) wherein the RTI plays its role. Two main areas can be distinguished related to the physical environment and the data handling.

The performance of passive RFID (range and rate) can be adversely affected by the presence of metal and/or liquids in the container, transport unit or (packaged) product. Appropriate shielding can be used to reduce interference.

If the process requires read rates in excess of 200 tags per second sequentially, parallel readings should be considered.

#### **11.4 Tag orientation**

It should be assumed that the handling operation is unable to predict the orientation of the individual (packed) products in the RTI and the individual small RTIs [crates, boxes, etc., in the large RTIs (roll containers, pallets, etc.)]. This can hamper the effective use of the reading equipment on site and/or *en route*.

#### **11.5 Packaging material**

A wide range of materials (such as wood, metal, plastic, glass, paper and textile) is utilized in primary packaging and small and large RTIs. Additionally, materials for coding and identification, in addition to branding and the representation of legally required information, are used. These can interfere with the RFID equipment.

#### **11.6 Shock loads and abrasions**

Typically, the various RTIs are subject to shock loads during the physical handling process. This can result in intentional or unintentional damage to the RFID tag. Placement and insertion of the tag should be done in such a way that damage due to shocks and/or cleaning is minimized.

#### **11.7 Tag lifetime**

Tags attached to the RTI will be used continuously throughout the life of the RTI.

All tags attached to the RTI may be used to facilitate the recycling of the RTI and the tag itself, e.g. by holding information on plastic type. In this respect, it could also be feasible to reuse the tag after reprogramming, provided it does not compromise the supply chain data structure. The exact implementation depends on cost of the tag and environmental implications of reuse/recycling.

#### **11.8 Minimum system reliability**

Systems where tags are positioned, programmed and presented to reading equipment in accordance with the provisions of 11.3 and ISO/IEC 18046 (all parts), shall have a minimum read reliability of 99,99 %, i.e. no more than one no-read event in 10 000 readings, and a read accuracy of 99,998 %, i.e. two undetected incorrect readings in 100 000 readings.

## 11.9 Air interface

The air interface specification recommended by this International Standard is ISO/IEC 18000-63, Type C. ISO/IEC 18000-2, Type A, the ASK air interface of ISO/IEC 18000-3, Mode 3, and ISO/IEC 18000-7 may be used with trading partner agreement. It is recommended that tags supporting ISO/IEC 18000-63, Type C also be able to support ISO/IEC 18000-3, Mode 3.

NOTE ISO/IEC 18000-2, Type A and ISO/IEC 18000-7 do not support EPC tags or data structures.

## 11.10 Memory requirements for application

The memory requirements for RTI RFID tags can be grouped into three basic categories: 96 bits, 256 bits and greater than 256 bits. Industry surveys have yielded recommendations for RF chip manufacturers to provide for 2 kbits and 4 kbits. Use of alternative memory requirements shall not result in changes to the minimum and mandatory data elements of their format or tag data structure, as otherwise specified in this International Standard.

## 11.11 Sensor interface, if applicable

Sensors and batteries integrated into or onto a tag and their tag operations or management shall not interfere with the operation of the tag as required by this International Standard.

Sensor-equipped RTI RFID tags shall conform to ISO/IEC/IEEE 21451-7 for the wired or wireless interface.

The 2,45 GHz O-QPSK option of ISO/IEC/IEEE 8802-15-4 and ISO/IEC/IEEE 21451-5 shall be used for the wireless interface between the tag/access point and the sensor.

## 11.12 Real time clock option

A real time clock shall be included with RTI RFID tags that are sensor equipped and where the application requires a time stamp. The accuracy of the time compared to actual Coordinated Universal Time (UTC) shall be no worse than  $\pm 5$  s per day. The representation of time shall be UTC ("Z" – Zulu) and formatted as described in ISO 8601, namely, yyyy-mm-ddThh:ssZ, for example 2012-01-01T14:55Z. When time is represented, the character "T" serves as the delimiter between "dd" and "hh".

## 11.13 Safety and regulatory considerations

All tags, interrogators and antennas conforming to this International Standard shall meet the safety and regulatory requirements of the country where the technology is used. The use of battery-assisted passive shall also be restricted in hazardous environments, such as near or around explosives or flammable gasses, unless these devices have been certified as safe for such use by the appropriate authorities.

## 11.14 Tag reusability

Technologically, all RFID tags are theoretically reusable. Because of the unique identification aspects of RTI, the permanent nature of the physical attachment of the tag and the low cost of the tags themselves, RTI level tags are generally not reused for commercial retail items and commodity items.

High-value and mission critical items can utilize higher functionality (read/write, larger memory and possibly sensors) tags, the cost of which can justify their reuse. Tags intended for reuse shall clearly be marked with appropriate human readable characters or logos to enable identification, reclamation and return. Prior to reuse, reusable tags shall have their headers checked for data integrity and user memory cleared.

## 12 Tag location and presentation

Guidelines for tag location and presentation can be found in ISO/IEC/TR 24729-1.



Tag location and presentation shall allow multi-reading and omni-reading simultaneously (at a gate) for the RTI and the products it contains. To minimize damage, the tag location should be recessed on the outside of the RTI or inside the RTI.

### **12.1 Material on which the tag is mounted or inserted**

The potential disturbance of metals and other reflective materials as well as liquids and other absorptive materials within the RTI shall be considered in the design to minimize disturbance of the RF signal.

### **12.2 Geometry of the package/tag environment**

Products/product packages and RTIs should be placed into RTIs in such a way to minimize the disturbance of the RF signal. This pertains to both the RTI and the items it is containing. See ISO/IEC/TR 24729-1.

### **12.3 Working environment**

Multiple washing of RTI tags shall be possible without damaging the RTI tag within the lifetime of the RTI. Stocking of RTIs in the open shall be possible without damaging the RTI and/or tag. This includes exposure to rain, dust, UV and other weather conditions.

## **13 Interrogator and reader requirements**

### **13.1 Safety and regulatory considerations**

All RFID tags and readers shall comply with IEEE C95-1 and ICNIRP Guidelines.

All tags, interrogators and antennas conforming to this International Standard shall meet the safety and regulatory requirements of the country where the technology is used. The use of passive or semi-passive (battery-assisted) RFID tags shall also be restricted in hazardous environments, such as near or around explosives or flammable gasses, unless these devices have been certified as safe for such use by the appropriate authorities.

### **13.2 Data privacy**

#### **13.2.1 Aggregated data**

Security of aggregated data shall be the responsibility of the collector. Data collectors and data storage operators shall comply with all applicable personal privacy regulations and rules governing the collection, storage and dissemination of personal data. Personal data collected by or incident to the reading of an RFID tag shall be accorded the same protection and security as personal data collected by any other means.

#### **13.2.2 Company proprietary data**

Company proprietary data shall be identified beforehand and companies wishing to restrict the collection of company proprietary data from RTI RFID tags shall utilize appropriate forms of data security. As security/protection of tag data can be compromised, use of RFID RTI tags to carry sensitive, classified or proprietary data should be limited.

## **14 Interoperability, compatibility and non-interference with other RF systems**

All RFID systems including tags, interrogators and readers shall operate on a strict non-interference basis with all other RF systems operating in the same spectrum. All RFID systems including tags, interrogators and readers claiming conformance with this International Standard shall be interoperable and compatible at the specific frequency designed.

## Annex A (informative)

### Returnable packaging items

#### A.1 General

The concepts of returnable, reusable, and recyclable are frequently used interchangeably, though conceptually they are quite different. A key underlying concept of difference is ownership, whereby returnable items maintain the original ownership, while the ownership of reusable and recyclable items is transferred between parties. [Figure A.1](#) shows a consumer lifecycle explaining the differences.

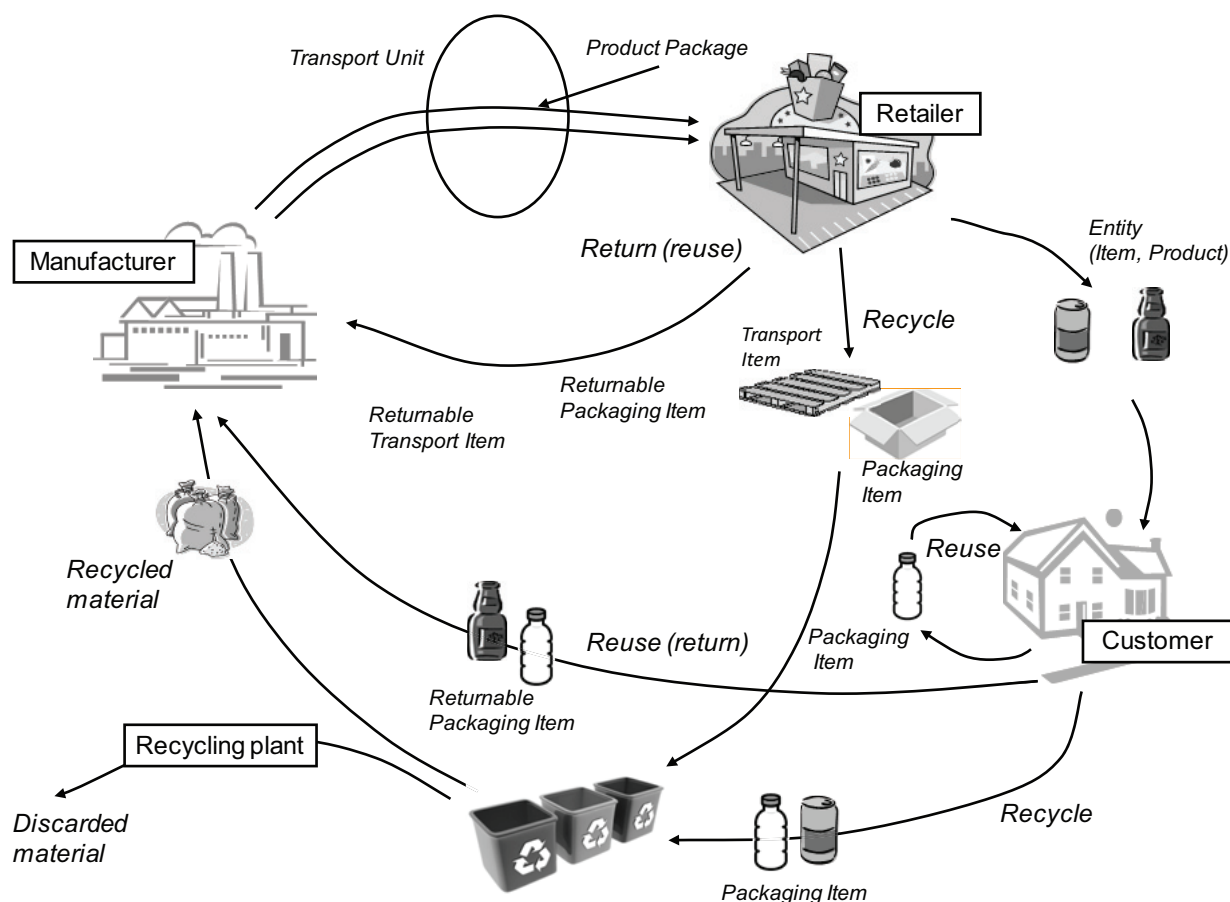

Figure A.1 — Returnable, reusable, and recyclable lifecycle

#### A.2 Recyclable item

With a recyclable item, the ownership of the item is transferred when the item is sold. A typical use recyclable item is a plastic bottle, which can be disposed at a recycling station and parts of the content can be recycled and used for manufacturing of new plastic bottles.

##### A.2.1 Identification

ISO/IEC 15459-4 addresses unique identification for individual recyclable items (products).

### **A.3 Reusable item**

With a reusable item, the ownership of the item is transferred when the item is sold. In some jurisdictions, an incentive to return the reusable packaging is provided at the time of purchase, such as a deposit, which can be recovered when the item is returned to the location from which the item was purchased.

A typical use recyclable item is a hard plastic bottle, which can either be reused by the user (i.e. filling the bottle with new content after cleaning it) or disposed at a recycling station and, depending on whether its constituents parts can be reused (i.e. cleaned and refilled) or recycled, used for “manufacturing” of new bottles.

#### **A.3.1 Identification**

ISO/IEC 15459-4 addresses unique identification for individual reusable items (products).

### **A.4 Returnable items**

With a returnable item the ownership of the item remains with the party providing the item, even though the item is sent to a customer. The supplier retains ownership of the asset with the anticipation that the customer will return the asset once it has served its original purpose.

A typical use of a returnable item is for transportation of goods where the item can be reused in that the content and carrier can change but the owner is still the same.

#### **A.4.1 Identification**

ISO/IEC 15459-5 addresses unique identification for returnable items.

### **A.5 Returnable transport items and returnable packaging items**

#### **A.5.1 Partitions**

Some pallets and returnable boxes are equipped with shock absorbing material to protect them from potential damage occurring during the transportation and handling process. An effective solution is the use of partitions or sorting boards for separating the contents into appropriate groups, making it possible to place many items on a single pallet or returnable box. This kind of accessory for a pallet or returnable box is defined as a “partition”. The typical example of this is a post-type partition used with the post pallet. Also included in this group is packing material used to place or arrange the contents between the posts, or packaging material for dividing the inside of the returnable box into several smaller sections.

#### **A.5.2 Posts**

[Figure A.2](#) shows a post that is normally used to securely fix packing materials or returnable box on the pallet. Most of these posts are made of highly durable substances like plastic or metal.

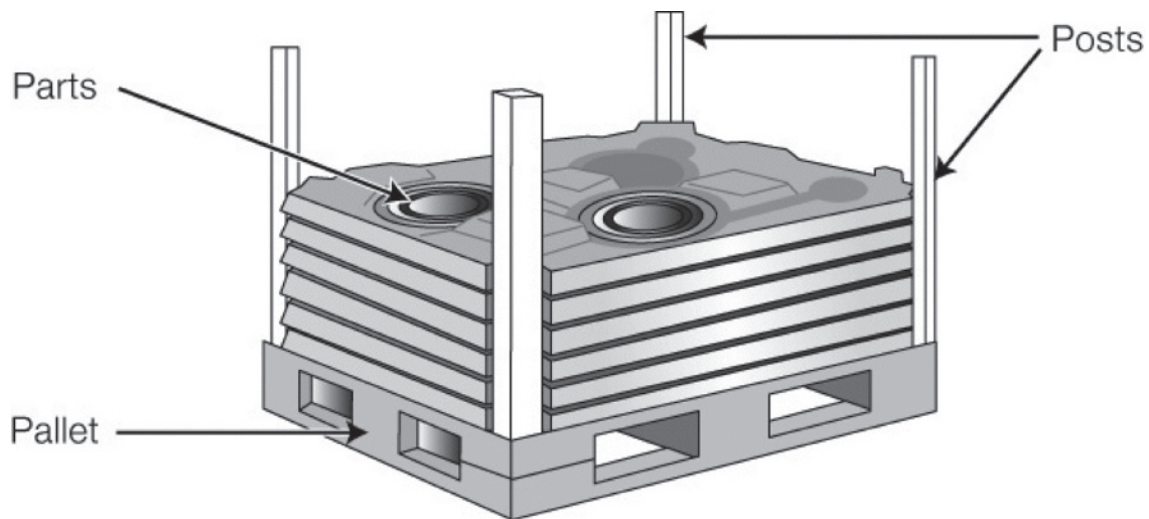

Figure A.2 — Post

### A.5.3 Packing materials

Some kind of packing materials should be provided to protect the items from a shock or vibration that may be encountered during transportation, or protect them from being touched or hit by the pallet or returnable box in which they are placed. Most of the packing materials are made of highly resilient flexible substances like plastic, urethane, and polystyrene foam. This guideline is applicable to these kinds of packing materials (see [Figure A.3](#) and [Figure A.4](#)).

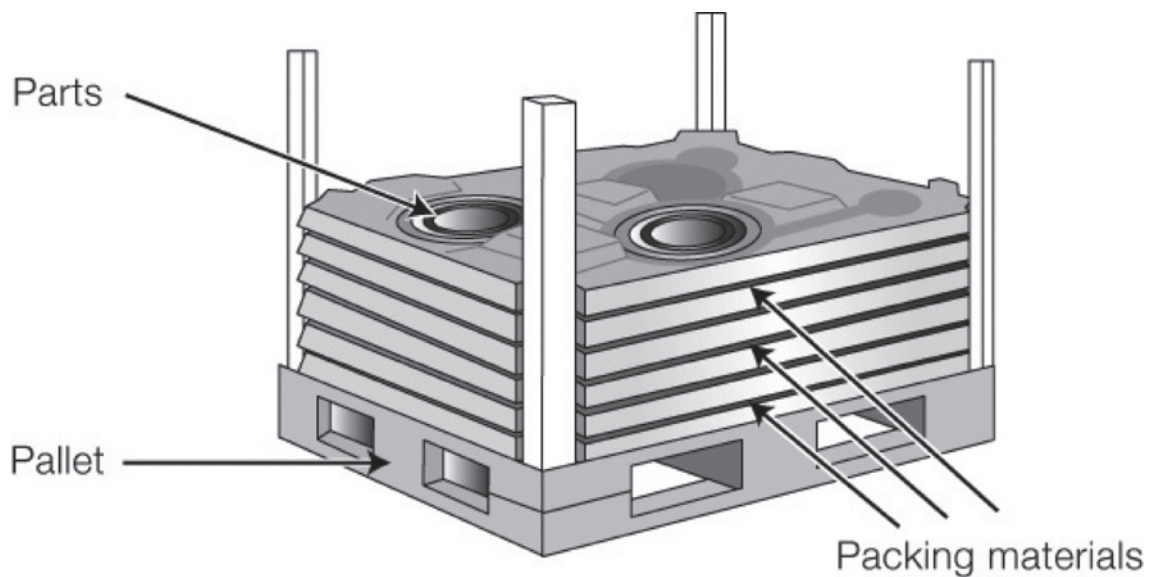
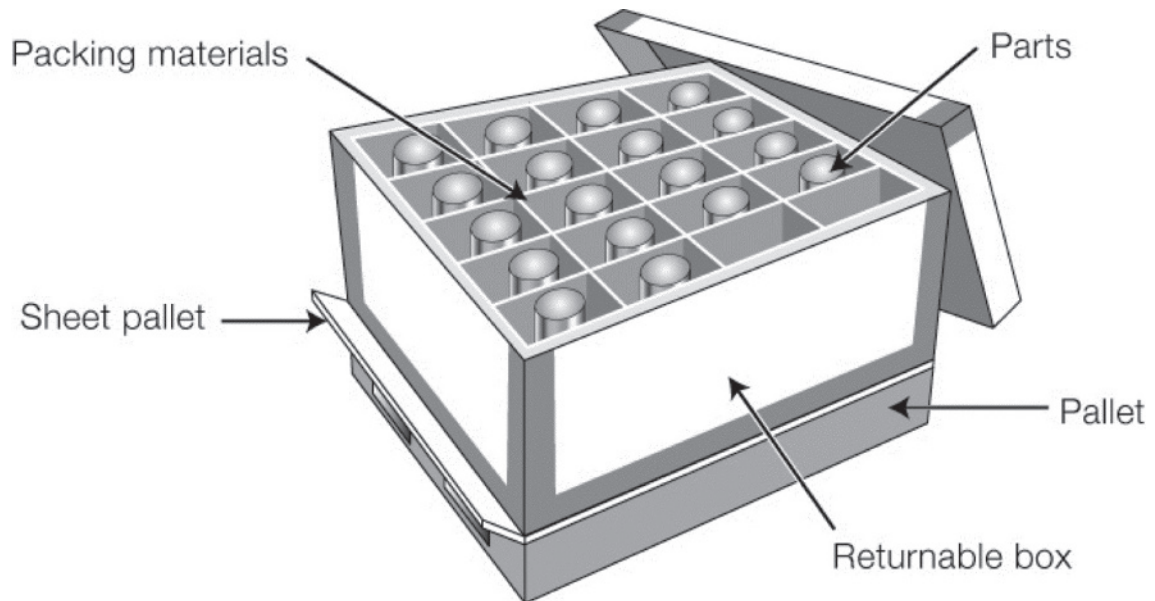

Figure A.3 — Packing material



**Figure A.4 — Packing material**

## **A.5.4 Identification**

This International Standard provides for a choice of two identification management patterns for users who manage all returnable transport items as a set or manage them independently. Mutual agreement between the trading partners shall identify which of the management patterns are to be used.

### **A.5.4.1 Returnable items managed as RTI set**

To manage returnable transport items shipped with transport unit, users should adopt a unique identity for the RTI set representing all RTIs and RPis included in each transport unit, e.g. pallet, returnable box, shock absorbing material, etc., and associate identity of each RTI as child element of its RTI set.

When managing RTIs mixed with transport units and products, an RTI set should be expressed as direct child of a transport unit.

#### **A.5.4.1.1 First example where returnable items are managed as an RTI set**

In [Figure A.5](#), the base pallet, the moulded plastic layers and posts are the actual RTIs. In this example, the RTI (set) is a representative of all returnable items and it may have a unique identity of "25BUN043325711R000001". The pallet, the four posts and the six plastic layers might have a unique identity described in the following two patterns layer chart which are manage RTI only or manage RTI with products.

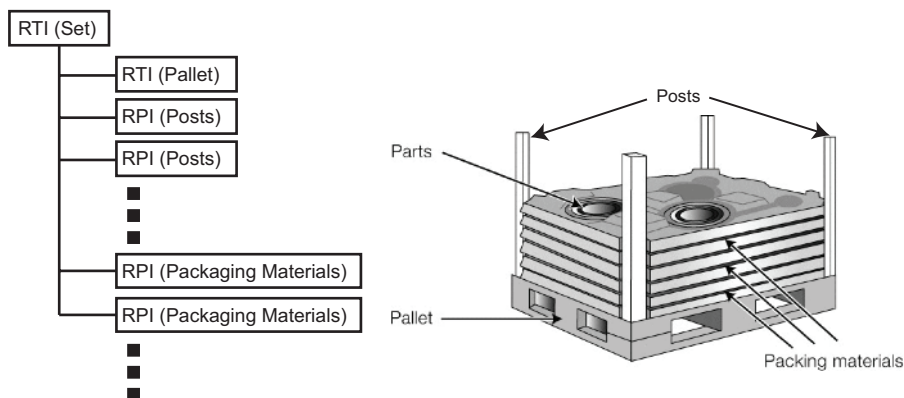

Figure A.5 — Returnable items managed as an RTI set — First example

A.5.4.1.1.1 Case (1): Returnable transport items only (separate from product shipment)

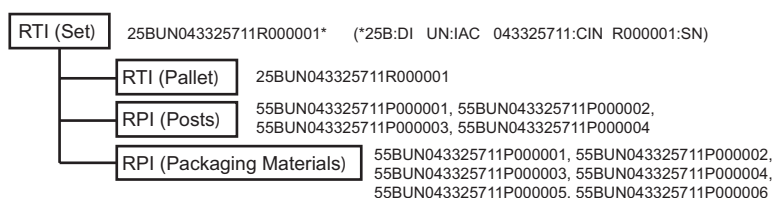

Figure A.6 — RTI set only — First example case 1

A.5.4.1.1.2 Case (2): Returnable transport items with product shipment

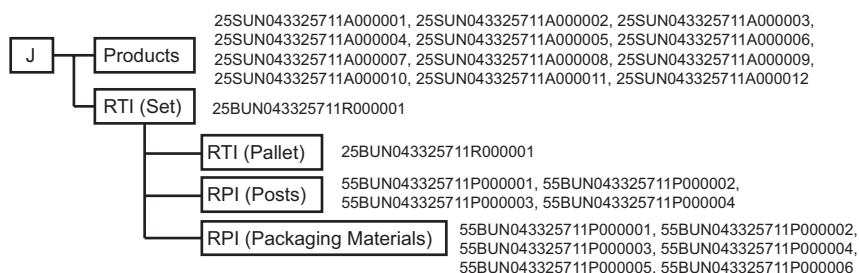

Figure A.7 — RTI set only — First example case 2

A.5.4.1.1.3 Second example where returnable items are managed as an RTI set

In [Figure A.7](#), the base pallet, the sheet pallet, the returnable box, the box lid, packaging materials are the actual RTIs. In this example, the RTI (set) represents all of the returnable items and has a unique identity of “25BUN043325711R000001”. The base pallet, the sheet pallet, the returnable box, the box lid, and packaging materials have a unique identity described in the following two-pattern layer chart that is managed as RTI only or managed as RTI with products.

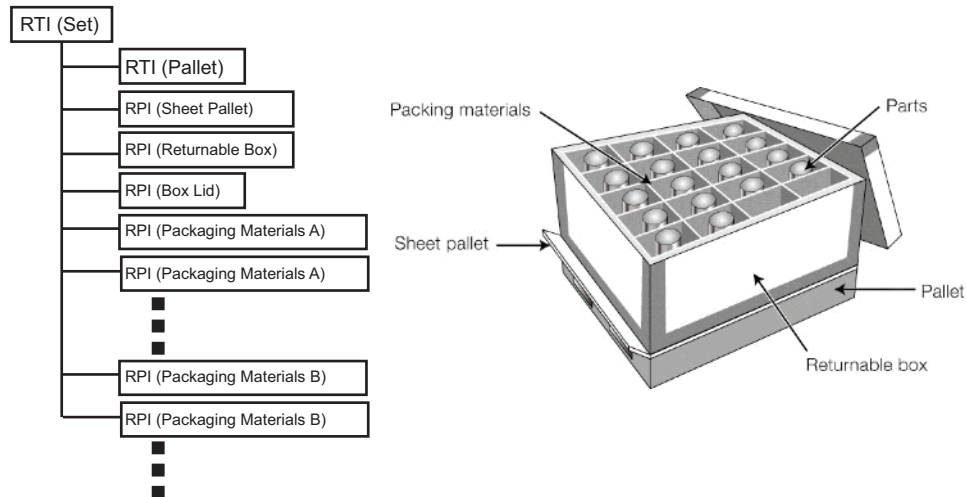

Figure A.8 — RTI set only — Second example

**A.5.4.1.1.4 Data example of returnable transport items only — Separate from product shipment**

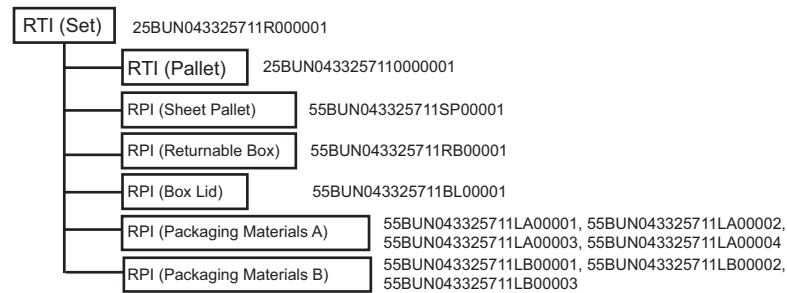

Figure A.9 — RTI set only — Second example case 1

**A.5.4.1.1.5 Data example of returnable transport items with products shipment**

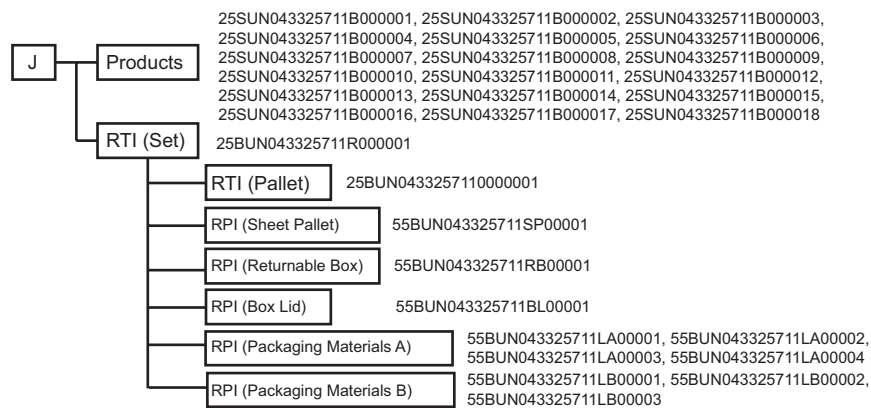

Figure A.10 — RTI set only — Second example case 2

**A.5.4.2 All returnable items are managed independently not as a set**

To manage all RTIs included in transport unit without having layered structure between the RTIs, all RTIs (pallet, returnable box, shock absorbing material, etc.) are dealt with independently.

When managing RTIs mixed with transport units and products, all RTIs are expressed as direct child of a transport unit, and expressed in the same layer as products.

**A.5.4.2.1 First example where returnable items are managed as an RTI set**

In [Figure A.3](#), the base pallet is the moulded plastic layers and posts are the actual RTIs. In this example, the pallet, the four posts and the six plastic layers might have a unique identity described in the following two-pattern layer chart which is manage RTI only or manage RTI with products.

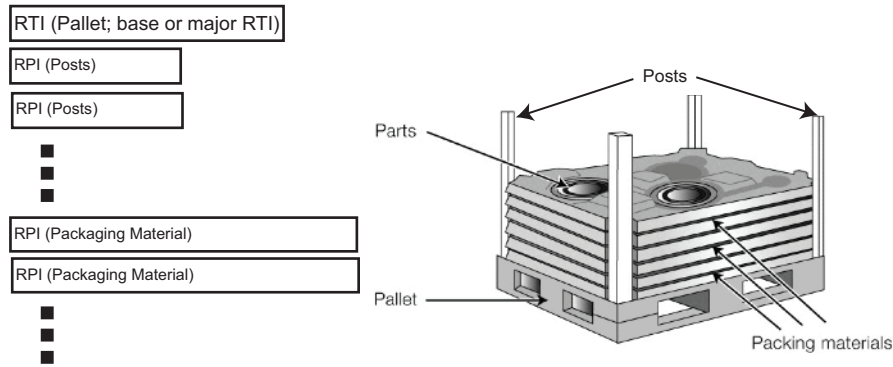

**Figure A.11 — Returnable items managed independently**

**A.5.4.2.1.1 Case (1): Returnable transport items only (separate from product shipment)**

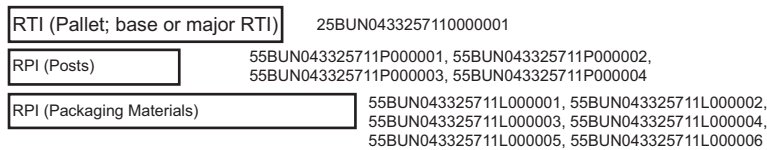

**Figure A.12 — Returnable items managed independently — First example case 1**

**A.5.4.2.1.2 Case (2): Returnable transport items with product shipment**

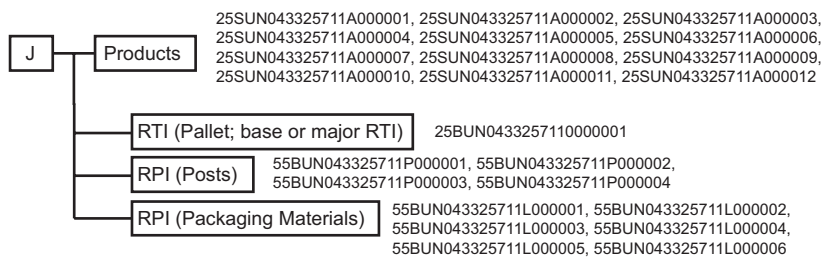

**Figure A.13 — Returnable items managed independently — First example case 2**

**A.5.4.2.2 Second example where returnable items are managed as an RTI set**

In [Figure A.13](#), the base pallet, the sheet pallet, the returnable box, the box lid and packaging materials are the actual RTIs. In this example, the base pallet, the sheet pallet, the returnable box, the box lid and packaging materials might have a unique identity described in the following two-pattern layer chart which is manage RTI only or manage RTI with products.



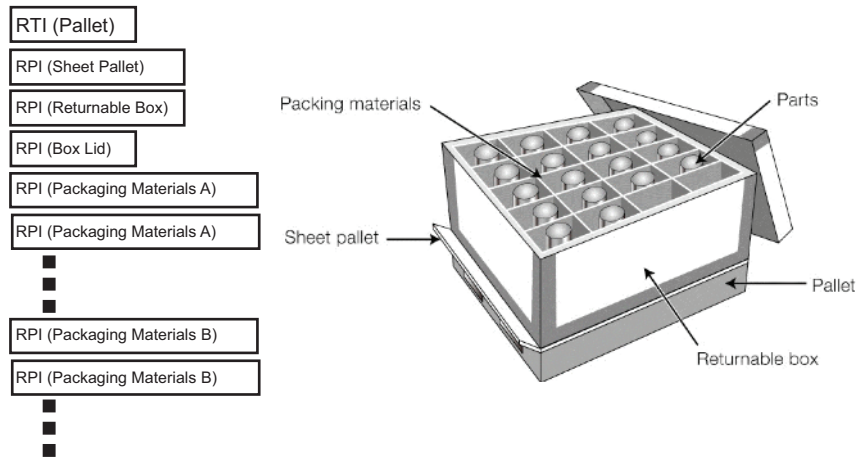

Figure A.14 — Returnable items managed independently — Second example

A.5.4.2.2.1 Case (1) Returnable transport items (separate from products shipment)

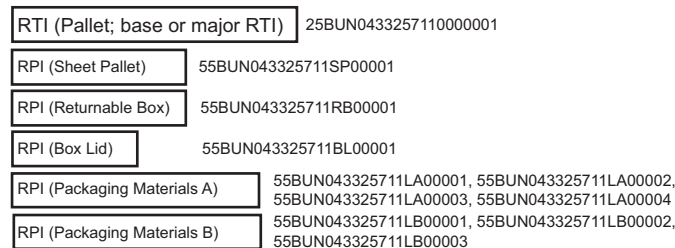

Figure A.15 — Returnable items managed independently — Second example case 1

A.5.4.2.2.2 Case (2) Returnable transport items with product shipment

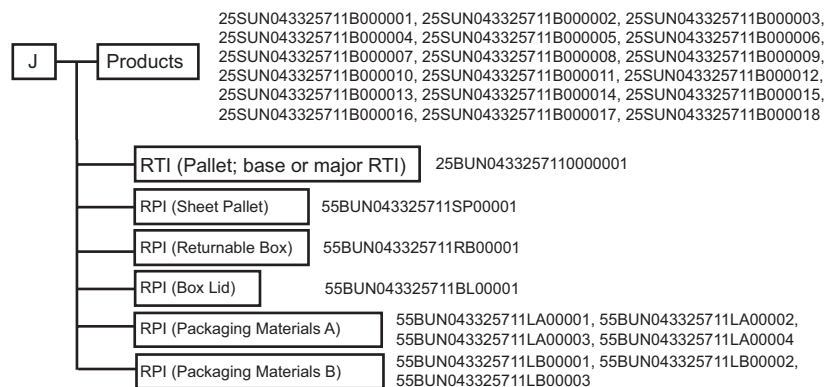

Figure A.16 — Returnable items managed independently — Second example case 2

A.5.4.3 All returnable items are managed independently and not as an RTI set

To manage returnable transport items included in a transport unit without having layered structure between RTIs and RPIs (pallet, returnable box, shock absorbing material, etc.) users should adopt a program of independent identification.

When managing RTIs as mixed with transport units and products, all RTIs are expressed as direct child of a transport unit, and express it as the same layer as a product.

In [Figure A.3](#), the base pallet is the actual RTI and the moulded plastic layers and posts are the RPIs. If each is serialized, it may be important to associate the RPIs with the parent RTI. In this example, the RTI may have a unique identity of “25BUN0433257110000001”. The four posts might have a unique identity, using the RPI Data Identifier “55B”, of

“55BUN043325711P0000001”

“55BUN043325711P0000002”

“55BUN043325711P0000003”

“55BUN043325711P0000004”

... and the six plastic layers might have a unique identity of

“55BUN043325711L0000001”

“55BUN043325711L0000002”

“55BUN043325711L0000003”

“55BUN043325711L0000004”

“55BUN043325711L0000005”

“55BUN043325711L0000006”

#### **A.5.4.4 My parent is ...**

One possibility to associate the RPIs with the parent RTI is with the use of the Data Identifier “1F” which declares, “My parent is ...” Using this example the 3<sup>rd</sup> plastic layer would be encoded

55BUN043325711L0000003<GS>1F25BUN0433257110000001.

The other layers and posts would be similarly encoded.

#### **A.5.4.5 I have \_\_\_ children and they are...**

Yet another possibility is to simply identify the number of RPIs associated with the parent RTI using the Data Identifier “5F” which declares, “I have \_\_\_ children and they are...”. Using the same example the base pallet would be encoded

25BUN0433257110000001<GS>5F10<GS>55BUN043325711L0000001<GS>55BUN043325711L0000002<GS>55BUN043325711L0000003<GS>55BUN043325711L0000004<GS>55BUN043325711L0000005<GS>55BUN043325711L0000006<GS>55BUN043325711P0000001<GS>55BUN043325711P0000002<GS>55BUN043325711P0000003<GS>55BUN043325711P0000004

#### **A.5.4.6 I have \_\_\_ children**

Yet another possibility is to simply identify the number of RPIs associated with the parent RTI using the Data Identifier “3F” which declares, “I have \_\_\_ children”. Using the same example the base pallet would be encoded

25BUN0433257110000001<GS>3F10

Likewise, any combination of the three associative DIs might be used.

## Annex B (normative)

### Encoding

This International Standard recommends three possible forms of encoding for ISO/IEC 18000-63, Type C and ISO/IEC 18000-3, Mode 3 RF tags:

- an EPC GS1 compliant form for either or both the Unique Item Identifier (UII) in Memory Bank “01” and User Memory in Memory Bank “11”. The segmentation of Type C and Mode 3 tags is illustrated in [Figure B.1](#) below. EPC encoding is detailed in GS1 EPC TDS 1.6;
- a structure employing ISO/IEC 15962;
- a simplified structure, encoding an entire ISO/IEC 15434 message as a unit, employing a no directory, encoding six-bit defined in ISO/IEC 15962 as described in the remainder of this annex.

#### B.1 Basics

Each of these encoding forms can be unambiguously discerned from the other by the content of bits 0x17 through 0x1F of Memory Bank “01”, as illustrated in [Figure B.2](#), and bits 0x00 through 0x1F of Memory Bank “11”.

When ISO/IEC 15434 was created, it was intended to support all AIDC media, including RFID. As RFID developed, a completely different set of encoding schema was developed around a set of standards, ISO/IEC 15961 and ISO/IEC 15962.

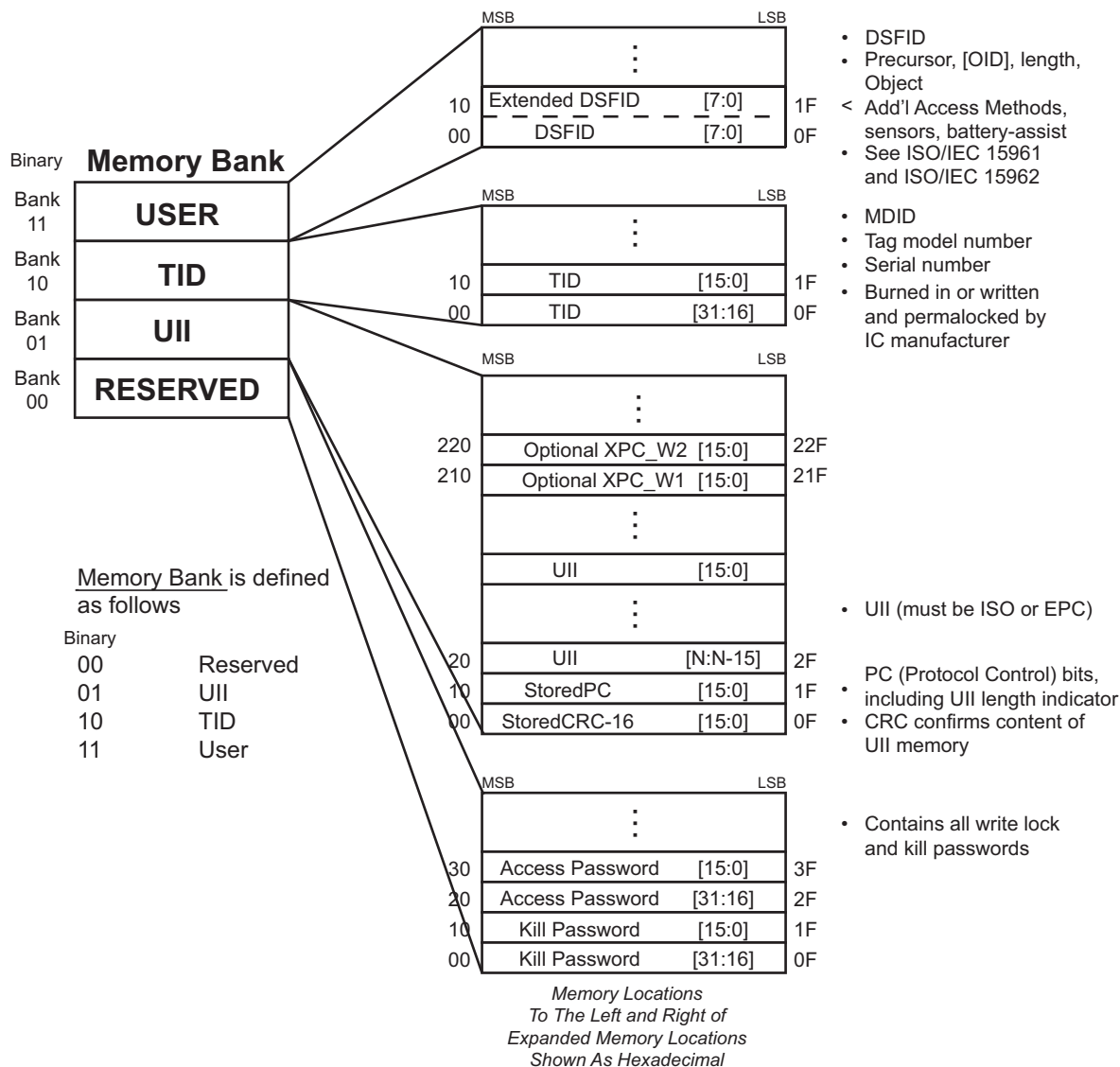

**Figure B.1 — ISO/IEC 18000-63, Type C and ISO/IEC 18000-3, Mode 3 Logical Memory Structure**

A key concept in this simplified encoding form, in both MB01 and MB11, is the use of a six-bit encoding as shown in Table B.1.

**Table B.1 — Six-bit encoding**

Space	100000	0	110000	@	000000	P	010000
<EOT>	100001	1	110001	A	000001	Q	010001
<Reserved>	100010	2	110010	B	000010	R	010010
<FS>	100011	3	110011	C	000011	S	010011
<US>	100100	4	110100	D	000100	T	010100
<Reserved>	100101	5	110101	E	000101	U	010101
<Reserved>	100110	6	110110	F	000110	V	010110
<Reserved>	100111	7	110111	G	000111	W	010111
(	101000	8	111000	H	001000	X	011000
)	101001	9	111001	I	001001	Y	011001
*	101010	:	111010	J	001010	Z	011010
+	101011	;	111011	K	001011	[	011011
,	101100	<	111100	L	001100	\	011100
-	101101	=	111101	M	001101	]	011101
.	101110	>	111110	N	001110	<GS>	011110
/	101111	?	111111	O	001111	<RS>	011111

NOTE Table B.1 is six-bit encoding created through the simple removal of the two high-order bits from the ISO/IEC 646-8-bit ASCII character set, save the shaded values. The shaded values are re-assigned, as provided, to minimize the bit count when using the ISO/IEC 15434 envelope.

The <Reserved> values in Table B.1 are not to be used without a re-issuance of this International Standard that reflects the defined values and functionality. An example would be a decision of the GS1 community to use this encoding and petitioning for the encoding of an ECI. Additionally, the presence of one or more of these characters might signal a different behaviour on the part of the decoder. While these <Reserved> values are not used in this iteration of this International Standard, they should not be used for any other purpose than defined by this International Standard.

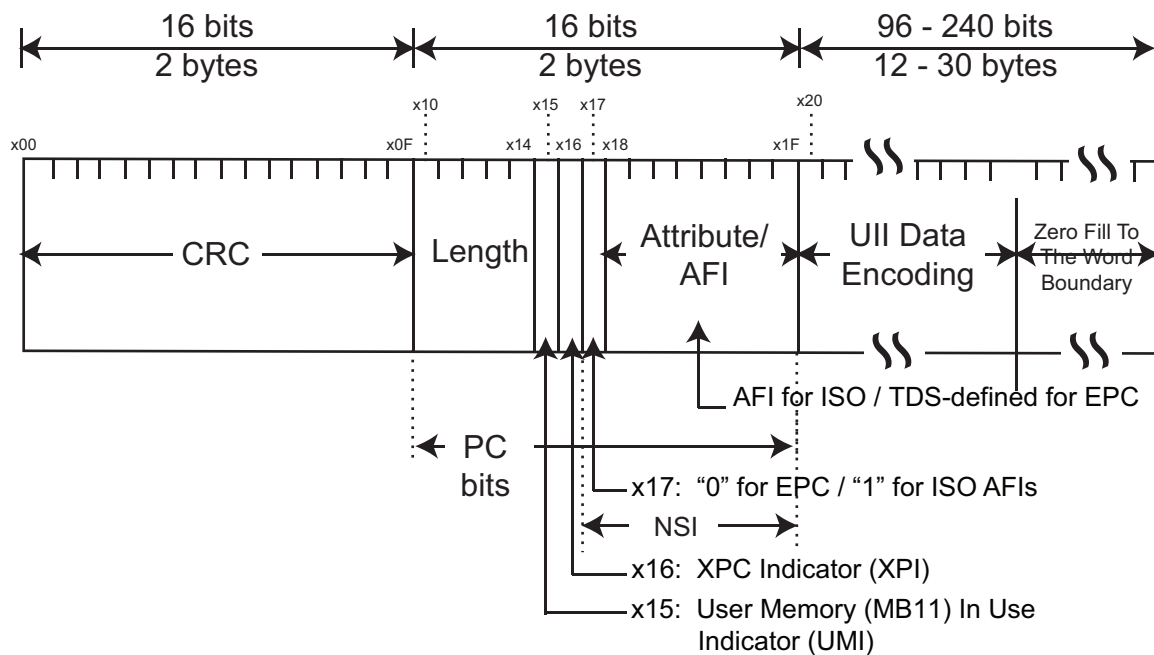

- Note 1 User Memory (MB11) in Use Indicator (UMI).
- Note 2 XPC Indicator.
- Note 3 "0=Binary / 1=AFI+ISO/IEC 15459".
- Note 4 AFI for ISO / TDS-defined for EPC / 29161 defined for ISO binary.
- Note 5 Last bit of AFI for ISO / Haz Mat for EPC.

**Figure B.2 — Type C and Mode 3 Structure of Memory Bank “01”**

## B.2 Encoding of Memory Bank “01” Unique Item Identifier

Bit 0x17 is the switch between ISO formats and EPC formats. When Bit 0x17 is set to a “0”, the UII encoding is as per the GS1 EPC Tag Data Standard, Version 1.6. When Bit 0x17 is set to a “1”, the UII encoding is as per ISO/IEC 15459 preceded by an ISO/IEC 15961, Application Family Identifier (AFI). The specific AFIs defined for the ISO 1736x series of International Standards are shown in [Table B.2](#).

**Table B.2 — 1736x Application Family Identifiers (AFIs)**

AFI	Assigned organization or function
0xA1	ISO 17367 product tagging
0xA2	ISO 17365 transport unit
0xA3	ISO 17364 returnable transport unit
0xA4	ISO 17367 product tagging, but for hazardous materials
0xA5	ISO 17366 product packaging
0xA6	ISO 17366 product packaging, but for hazardous materials
0xA7	ISO 17365 transport unit, but containing hazardous materials
0xA8	ISO 17364 returnable transport unit, but containing hazardous materials
0xA9	ISO 17363 freight containers
0xAA	ISO 17363 freight containers, but containing hazardous materials

For the purposes of illustration, encoding of a product is shown. Transport units would be identically encoded except for the AFI and the DI. A linear bar code symbol encoding the data providing unique item identification is comprised of the Data Identifier (DI), Issuing Agency Code (IAC), Company Identification (CIN), and Serial Number (SN). Such a unique item identification linear bar code would be represented in Code 128 as shown in [Figure B.3](#).

- DI = 25S
- IAC = UN (DUNS)
- CIN = 043325711
- SN = MH8031200000000001

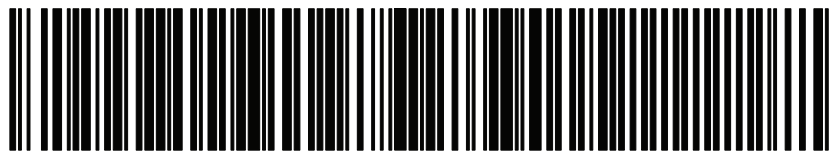

**Figure B.3 — Code 128 encoding “25SUN043325711MH8031200000000001”**

Adding the AFI to the structure for RFID purposes we have

- AFI = 0xA1
- DI = 25S
- IAC = UN (DUNS)
- CIN = 043325711
- SN = MH8031200000000001

Looking then at a completed data structure, using the encoding defined above and using DUNS as the Issuing Agency Code (IAC), we find that MB01, when encoding a product, this data structure is 25SUN043325711MH8031200000000001 and is represented in MB01 as follows:

**Table B.3 — MB01 structure of AFI and UII (DUNS) using six-bit encoding**

AFI = 0xA1			2	5	S	U	N	0	4	3	3	2	5	7	1
1010 0001			110010	110101	010011	010101	001110	110000	110100	110011	110011	110010	110101	110111	110001
<b>1</b>	<b>M</b>	<b>H</b>	<b>8</b>	<b>0</b>	<b>3</b>	<b>1</b>	<b>2</b>	<b>0</b>	<b>0</b>	<b>0</b>	<b>0</b>	<b>0</b>	<b>0</b>	<b>0</b>	<b>0</b>
110001	001101	001000	111000	110000	110011	110001	110010	110000	110000	110000	110000	110000	110000	110000	110000
<b>0</b>	<b>0</b>	<b>1</b>													
110000	110000	110001													

Alternatively, looking at a completed data structure using the encoding defined above, using ODETTE as the Issuing Agency Code (IAC), we find that MB01 when encoding a product has an:

- AFI = 0xA1
- DI = 25S
- IAC = OD (ODETTE)
- CIN = CIN1
- SN = 0000000RTIA1B2C3DOSN12345 (This example shows the SN composed of Object Type and Object Serial Number)

... we have an MB01 structure as shown in [Table B.4](#).

**Table B.4 — MB01 structure of AFI and UII (ODETTE) using six-bit encoding**

AFI = 0xA1			2	5	S	O	D	C	I	N	1	0	0	0	0
1010 0001			110010	110101	010011	001111	000100	000011	001001	001110	110001	110000	110000	110000	110000
0	0	0	R	T	I	A	1	B	2	C	3	D	O	S	N
110000	110000	110000	010010	010100	001001	000001	110001	000010	110010	000011	110011	000100	001111	010011	001110
1	2	3	4	5											
110001	110010	110011	110100	110101											

In both cases, once the AFI is stripped from the message, the output of the RFID reader is identical to that of the linear bar code.

### B.3 Encoding of Memory Bank “11” User Memory

To indicate that data resides in MB11 (User Memory) bit 0x15 of MB01 is set to a “1”. Likewise, the presence of an AFI in MB01 cannot declare the format for MB11 because some users may choose to implement EPC encoding for MB01 and ISO encoding for MB11, in cases where MB01 is to be read by retailers and MB11 by industrial consumers. Further, it is preferable that there exists no confusion between the structures defined herein and those defined in ISO/IEC 15962. Consequently, MB11 shall declare its access method and format.

#### B.3.1 DSFID

Data encoding starts with the DSFID (Data Storage Format Identifier) that encodes the access method and Data Format. When using direct ISO/IEC 15434 encoding, the DSFID is “0x03”. See [Figure B.4](#) for how this byte fits into the sequence of the first three encoded bytes.

##### B.3.1.1 Precursor byte

Data encoding continues with the Precursor and it encodes the extension bit in the most significant position, the compaction type (next three bits) and the ISO/IEC 15434 format envelope (four least significant bits). For ISO/TC 122 applications the only permitted Precursor is byte “0 100 0110” or “0x46” (i.e. extension bit is a “0” in the case of no sensors or battery assist, a compaction type 4 which indicates use of the special 6-bit table defined in this annex and an ISO/IEC 15434 format envelope “06”). See [Figure B.4](#) for how this byte fits into the sequence of the first three encoded bytes.

##### B.3.1.2 Data byte-count indicator

Some air interface protocols allow for optimization in noisy environments by varying the number of bytes sent in each transmission. Therefore, it is useful to know at the beginning the number of bytes in tag memory that contain data. For many ISO/IEC 15434, DI data encoding applications, the number of bytes needed to encode the data will be a number less than 127 and therefore handled in one byte. For larger messages, two bytes are used where the first byte begins with “1” and the second byte begins with “0” as in ISO/IEC 15962:—, D.2. The number of bytes is encoded in the 14 remaining bits (e.g. 200 bytes is encoded as “10000001 01001000”).

For example, if a message contains 51 6-bit characters, it will be encoded in 39 bytes (i.e. the last bit of the last character is in the 39<sup>th</sup> byte and in this case there are six un-encoded bits which require padding). Therefore, the data byte-count indicator is “0x27”. See [Figure B.4](#) for how this byte fits into the sequence of the first three encoded bytes.



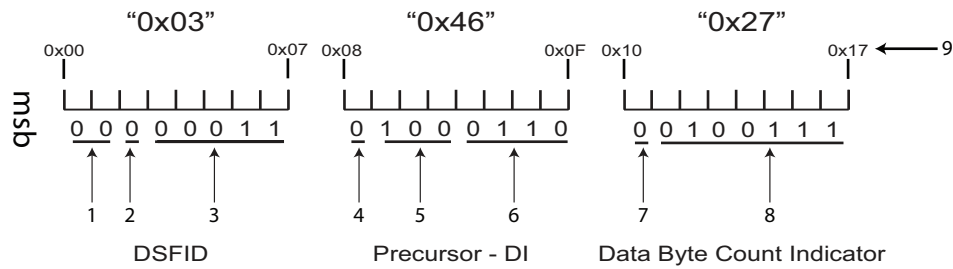

- NOTE 1 Access Method (#0 as listed in Table 7 of ISO/IEC 15962:—).
- NOTE 2 Extended Syntax – turns on additional byte of DSFID byte (turned off in this instance).
- NOTE 3 Data Format 03 (ISO/IEC 15434).
- NOTE 4 Extension Bit – not specified in this example.
- NOTE 5 Compaction bits (indicating 6-bit table).
- NOTE 6 Format Envelope (specifically DI "06").
- NOTE 7 Byte Count Indicator switch (set to "0" to signify final byte of byte count).
- NOTE 8 Bit values for Byte Count Indicator (variable based on length of data).
- NOTE 9 Physical memory addresses (0x00, 0x07, 0x08, 0x0F, 0x10, and 0x17).
- NOTE 10 For the purpose of the above example battery-assist and sensors are shown as not present.

**Figure B.4 — Type C and Mode 3 structure of Memory Bank "11" 1st 24 bits**

## B.4 Encoding and decoding

### B.4.1 Encode process

- Starting with a valid ISO/IEC 15434, DI message, strip "[ ] > RS 06 GS" from the front and "<RS> <EOT>" from the end.
- Convert every data character into its code value using Table B.1.
- When encoding multiple "06" Format Envelopes (e.g. to represent a message containing several "records" from the same data format in order to describe the subassemblies of a complex part) reduce each internal ISO/IEC 15434 sequence "<RS> <06> <GS>" indicating a new "record" to a single <RS> character (encoded as "011111" from Table B.1).
- Encode an <EOT> pattern after the last encoded data character.
- Lay out the 6-bit characters as bits and then group them into 8-bit bytes.
- Add the first 2 or 4 bits of an <EOT> character (i.e. "10" or "1000") or the entire <EOT> character (i.e. "100001" from the 6-bit character set) to fill un-encoded bits in the last byte, if any, as padding bits.
- Determine the byte number that contains the last bit of the <EOT> character, convert the decimal count into binary and encode explicitly as the data byte-count indicator.
- Encode the DSFID, Precursor, data byte-count indicator, data, <EOT> and padding bits (if any) into memory.

NOTE Because only one ISO/IEC 15434 message is allowed to be encoded in a single RFID data carrier, there is no need to encode a zero byte as a terminator after the last data byte.

## B.4.2 Decode process

1. Examine the DSFID and Precursor bytes and verify that they are equivalent to "0x03 0x46".
2. Process the next 8 bits, convert to decimal to determine the number of bytes containing data.
3. Starting with the next bit, group the following bits into character bit-sets from the 6-bit code table and continue until the number of bytes containing data has been parsed.
4. Assign data characters according to Table B.1 and delete all complete and incomplete <EOT> characters from the end.
5. For any encoded <RS> character that is not immediately followed by "06" and a <GS> character, expand the <RS> to "RS 06 GS".
6. Add "[ ] > RS 06 GS" to the beginning of the transmission and "RS EOT" at the end.
7. Transmit the entire ISO/IEC 15434 compliant message. Optionally, the receiver may wrap the ISO/IEC 15434 message in an OID format as a single data object. When using this option, the complete OID of the message is {1 0 15434 06}.

## B.5 Encoding and decoding example

### B.5.1 Translation and encoding procedure from ISO/IEC 15434 data to Access Method 0 Data Format 3

To prepare a typical DI input message in ISO/IEC 15434 format for encoding using ISO/IEC 15962, Access Method 0 Data-Format 3, the following steps are performed.

Verify that the input message is a valid ISO/IEC 15434, DI message.

The DSFID indicating Access Method 0 and Data Format 3 is encoded.

The leading message envelope characters "[ ] > RS 06 GS" and the trailing "RS EOT" are discarded.

The data is encoded into 6-bit codewords from Table B.1.

Add an <EOT> character.

Add part or all of an <EOT> to fill the last data byte, if necessary.

Encode the DSFID, Precursor, data byte-count indicator, data, <EOT> and padding into memory.

### B.5.2 Decoding and translation procedure from Access Method 0 Data-Format 3 to ISO/IEC 15434 data

The system will see this information as ISO/IEC 15434-6 bit DI data by reading the DSFID byte.

The system discards the DSFID, Precursor and data byte-count indicator at the beginning.

The encoded bytes are parsed into 6-bit codes, discarding any pad bits and the encoded <EOT> character, and then into data according to Table B.1.

The system adds "[ ] > RS 06 GS" to the beginning of the transmission and "RS EOT" at the end.

The system transmits the entire ISO/IEC 15434 compliant message.

Optionally, the receiver may wrap the entire ISO/IEC 15434 message in an OID format as a single data object.

### B.5.3 Data encode and decode example

The following example encodes ISO/IEC 15434, DI data in an application with a mandatory <EOT> requirement.

Starting data:

]><RS>06<GS>25SUN043325711MH8031200000000001<GS>1T110780<GS>Q21<GS>4LUS<RS><EOT>

The data on the tag from the above message is as follows (with DIs in bold font):

**25**SUN043325711MH8031200000000001 <GS> **1T**110780 <GS> **Q**21 <GS> **4L**US <EOT>

Where:

UII = **25**SUN043325711MH8031200000000001

LOT = **1T**110780

QTY = **Q**21

CoO = **4L**US

Data to bit conversion:

There are 51 6-bit characters (50 plus <EOT>), which translates to 39 data bytes. There is a need to fill six trailing bits for byte alignment so in this case an entire <EOT> character is encoded. See [Table B.5](#).

**Table B.5 — Type C and Mode 3 structure of Memory Bank “11” 1<sup>st</sup> 16 bits**

DSFID = 0x03	Precursor = 0x46	Data byte- count = 0x27	2	5	S	U	N	0	4	3	3	2	5
00000011	01000110	00100111	110010	110101	010011	010101	001110	110000	110100	110011	110011	110010	110101
<b>7</b>	<b>1</b>	<b>1</b>	<b>M</b>	<b>H</b>	<b>8</b>	<b>0</b>	<b>3</b>	<b>1</b>	<b>2</b>	<b>0</b>	<b>0</b>	<b>0</b>	<b>0</b>
110111	110001	110001	001101	001000	111000	110000	110011	110001	110010	110000	110000	110000	110000
<b>0</b>	<b>0</b>	<b>0</b>	<b>0</b>	<b>0</b>	<b>0</b>	<b>1</b>	<GS>	<b>1</b>	<b>T</b>	<b>1</b>	<b>1</b>	<b>0</b>	<b>7</b>
110000	110000	110000	110000	110000	110000	110001	011110	110001	010100	110001	110001	110000	110111
<b>8</b>	<b>0</b>	<GS>	<b>Q</b>	<b>2</b>	<b>1</b>	<GS>	<b>4</b>	<b>L</b>	<b>U</b>	<b>S</b>	<EOT>	<b>pad</b>	
111000	110000	011110	010001	110010	110001	011110	110100	001100	010101	010011	100001	100001	

#### B.5.3.1 Complete contents of tag memory

Using the Access Method 0 Format 3 encoding, including a DSFID, ISO/IEC 15434, Precursor byte, 39 bytes of data (compressing 51 6-bit characters including the <EOT>) and six pad bits, the final tag encodation in hexadecimal is as follows.

03 46 27 CB 54 D5 3B 0D 33 CF 2D 77 C7 13 48 E3 0C F1 CB 0C 30 C3 0C 30 C3 0C 31 7B 15 31 C7 0D F8 C1 E4 72 C5 ED 0C 55 38 61

#### B.5.3.2 Transmitted data

The header characters and the “<RS> <EOT>” are reinserted into the message. The following data string is transmitted from the reader.

]> R<sub>S</sub> 06 G<sub>S</sub> 25SUN043325711MH8031200000000001 G<sub>S</sub> 1T110780 G<sub>S</sub> Q21 G<sub>S</sub> 4LUS R<sub>S</sub> EOT

### B.5.3.3 Conclusion

Using the Direct DI Only Encoding Six-Bit approach, the encoding of MB01 of an ISO/IEC 18000-63, Type C or an ISO/IEC 18000-3, Mode 3 RF tag will provide the same output as [Figure B.3](#), supra. Using the Direct DI Only Encoding Six-Bit approach, the encoding of MB11 of an ISO/IEC 18000-63, Type C or an ISO/IEC 18000-3, Mode 3 RF tag will provide the same output as [Figure B.5](#), below. This method also has the benefit of simplifying the data encoding process. When encoded in a 2D symbol, the output would be identical:



Figure B.5 — QR Code encoding the contents of MB01 and MB11 `] > <RS>06<GS>25SUN0433257  
11MH8031200000000001 <GS>1T110780<GS>Q21<GS>4LUS<RS><EOT>`

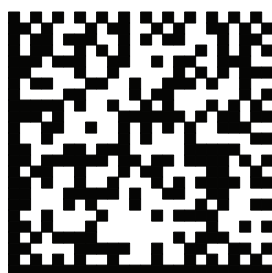

Figure B.6 — DataMatrix encoding the contents of MB01 and MB11 `] > <RS>06<GS>25SUN04332  
5711MH8031200000000001 <GS>1T110780<GS>Q21<GS>4LUS<RS><EOT>`

## Annex C (informative)

### Table of useful data elements for product life cycle management

**Table C.1 — Useful data elements for product life cycle management**

<b>Name</b>	<b>Classification</b>	<b>Item</b>	<b>Explanation</b>	<b>Bytes</b>
TID	TID	TID	Tag Identification Number (ISO/IEC 15963)	(32 bits)
UII	Product identification code assigned by manufacturers (ISO/IEC 15459-4)	EPC	(SGTIN)	(96 bits)
		Data Identifier	Serialized item number ("25S")	3+50
		Issuing Agency Code		
		Manufacturer code		
		Product code	Example: CF-L2M8WAXS	
Serial number	Example: 3AKSB01019			

Table C.1 (continued)

Name	Classification	Item	Explanation	Bytes
User memory	Internal code of manufacturers			30
	Hazardous material	Hazardous material flag	Hazardous material flag	1
		Products revision	Revision identification number of products	5
	Data for maintenance (This data is for maintenance person's use at consumer's office or home)	Maintenance contract date	Maintenance contract date between maintenance company and user (YYM-MDD)	6
		Parts exchange flag	Flag that indicates some parts were exchanged for new parts	1
		Consumable supply flag	Consumable supply flag	1
		Supplies change date	Date consumable supplies put into service (YYMMDD)	6
		Durable hours	How many hours is it possible to use the supply for	1
		Data for Recycling (This data is used in a recycle phase and resale)	Recycle application date	Date that recycle application form was made (Date that user delivers recycle products to recycle company or carrier) YYMMDD
	Recycle application ID number		Number assigned to recycle product to identify each product.	11
	Product classification		Product classification flag (Classification example: Desktop PC, Laptop) This flag is used to pre-sort the products in recycle operation.	2
	Manufacturing date		Manufacturing date YYYYMMDD	8
	Durability period		Durable years from manufacturing date	2
	Resale date		Resale date of lease products (YYMMDD), Product no longer subject to manufacturer's guarantee.	6
	Resale dealer		Identification code of resale dealers	10
			Total	155 bytes

## Bibliography

- [1] ISO/IEC 646, *Information technology — ISO 7-bit coded character set for information interchange*
- [2] ISO 3166-1, *Codes for the representation of names of countries and their subdivisions — Part 1: Country codes*
- [3] ISO/IEC/IEEE 8802 (all parts), *Information technology — Telecommunications and information exchange between systems — Local and metropolitan area networks — Specific requirements*
- [4] ISO 15394, *Packaging — Bar code and two-dimensional symbols for shipping, transport and receiving labels*
- [5] ISO/IEC 15417, *Information technology — Automatic identification and data capture techniques — Code 128 bar code symbology specification*
- [6] ISO/IEC 15459-1, *Information technology — Automatic identification and data capture techniques — Unique identification — Part 1: Individual transport units*
- [7] ISO/IEC 15459-2, *Information technology — Automatic identification and data capture techniques — Unique identification — Part 2: Registration procedures*
- [8] ISO/IEC 15459-4, *Information technology — Automatic identification and data capture techniques — Unique identification — Part 4: Individual products and product packages*
- [9] ISO/IEC 16022, *Information technology — Automatic identification and data capture techniques — Data Matrix bar code symbology specification*
- [10] ISO 17363, *Supply chain applications of RFID — Freight containers*
- [11] ISO 17366, *Supply chain applications of RFID — Product packaging*
- [12] ISO/IEC 18000 (all parts), *Information technology — Radio frequency identification for item management*
- [13] ISO/IEC/TR 18001, *Information technology — Radio frequency identification for item management — Application requirements profiles*
- [14] ISO/IEC 18004, *Information technology — Automatic identification and data capture techniques — QR Code bar code symbology specification*
- [15] ISO 18185 (all parts), *Freight containers — Electronic seals*
- [16] ISO/IEC/IEEE 21451-5 [IEEE 1451.5], *Information technology — Smart Transducer Interface for Sensors and Actuators — Wireless Communication Protocols and Transducer Electronic Data Sheet (TEDS) Formats*
- [17] ISO 22742:2010, *Packaging — Linear bar code and two-dimensional symbols for product packaging*
- [18] ISO/IEC/TR 24729-2, *Information technology — Radio frequency identification for item management — Implementation guidelines — Part 2: Recycling and RFID tags*
- [19] ISO/IEC 29160, *Information technology — Radio frequency identification for item management — RFID Emblem*
- [20] *AIM Global Standard for the use of the AIM RFID Emblem and index to identify RFID-enabled labels*
- [21] EIA 802, *Product Marking Standard*
- [22] EPC™, *Radio-Frequency Identity Protocols Class-1 Generation — 2 UHF RFID Protocol for Communications at 860 MHz — 960 MHz, Version 1.0.9*

[23] EPC, *Tag Notification Brand Guidelines*









# British Standards Institution (BSI)

BSI is the national body responsible for preparing British Standards and other standards-related publications, information and services.

BSI is incorporated by Royal Charter. British Standards and other standardization products are published by BSI Standards Limited.

## About us

We bring together business, industry, government, consumers, innovators and others to shape their combined experience and expertise into standards-based solutions.

The knowledge embodied in our standards has been carefully assembled in a dependable format and refined through our open consultation process. Organizations of all sizes and across all sectors choose standards to help them achieve their goals.

## Information on standards

We can provide you with the knowledge that your organization needs to succeed. Find out more about British Standards by visiting our website at [bsigroup.com/standards](http://bsigroup.com/standards) or contacting our Customer Services team or Knowledge Centre.

## Buying standards

You can buy and download PDF versions of BSI publications, including British and adopted European and international standards, through our website at [bsigroup.com/shop](http://bsigroup.com/shop), where hard copies can also be purchased.

If you need international and foreign standards from other Standards Development Organizations, hard copies can be ordered from our Customer Services team.

## Subscriptions

Our range of subscription services are designed to make using standards easier for you. For further information on our subscription products go to [bsigroup.com/subscriptions](http://bsigroup.com/subscriptions).

With **British Standards Online (BSOL)** you'll have instant access to over 55,000 British and adopted European and international standards from your desktop. It's available 24/7 and is refreshed daily so you'll always be up to date.

You can keep in touch with standards developments and receive substantial discounts on the purchase price of standards, both in single copy and subscription format, by becoming a **BSI Subscribing Member**.

**PLUS** is an updating service exclusive to BSI Subscribing Members. You will automatically receive the latest hard copy of your standards when they're revised or replaced.

To find out more about becoming a BSI Subscribing Member and the benefits of membership, please visit [bsigroup.com/shop](http://bsigroup.com/shop).

With a **Multi-User Network Licence (MUNL)** you are able to host standards publications on your intranet. Licences can cover as few or as many users as you wish. With updates supplied as soon as they're available, you can be sure your documentation is current. For further information, email [bsmusales@bsigroup.com](mailto:bsmusales@bsigroup.com).

## BSI Group Headquarters

389 Chiswick High Road London W4 4AL UK

## Revisions

Our British Standards and other publications are updated by amendment or revision.

We continually improve the quality of our products and services to benefit your business. If you find an inaccuracy or ambiguity within a British Standard or other BSI publication please inform the Knowledge Centre.

## Copyright

All the data, software and documentation set out in all British Standards and other BSI publications are the property of and copyrighted by BSI, or some person or entity that owns copyright in the information used (such as the international standardization bodies) and has formally licensed such information to BSI for commercial publication and use. Except as permitted under the Copyright, Designs and Patents Act 1988 no extract may be reproduced, stored in a retrieval system or transmitted in any form or by any means – electronic, photocopying, recording or otherwise – without prior written permission from BSI. Details and advice can be obtained from the Copyright & Licensing Department.

## Useful Contacts:

### Customer Services

**Tel:** +44 845 086 9001

**Email (orders):** [orders@bsigroup.com](mailto:orders@bsigroup.com)

**Email (enquiries):** [cservices@bsigroup.com](mailto:cservices@bsigroup.com)

### Subscriptions

**Tel:** +44 845 086 9001

**Email:** [subscriptions@bsigroup.com](mailto:subscriptions@bsigroup.com)

### Knowledge Centre

**Tel:** +44 20 8996 7004

**Email:** [knowledgecentre@bsigroup.com](mailto:knowledgecentre@bsigroup.com)

### Copyright & Licensing

**Tel:** +44 20 8996 7070

**Email:** [copyright@bsigroup.com](mailto:copyright@bsigroup.com)



...making excellence a habit.™