

BS ISO 17248:2015



BSI Standards Publication

Corrosion of metals and alloys — Test method for high temperature corrosion testing of metallic materials by embedding in salt, ash, or other solids

bsi.

...making excellence a habit.™

National foreword

This British Standard is the UK implementation of ISO 17248:2015.

The UK participation in its preparation was entrusted to Technical Committee ISE/NFE/8, Corrosion of metals and alloys.

A list of organizations represented on this committee can be obtained on request to its secretary.

This publication does not purport to include all the necessary provisions of a contract. Users are responsible for its correct application.

© The British Standards Institution 2015. Published by BSI Standards Limited 2015

ISBN 978 0 580 78212 1

ICS 77.060

Compliance with a British Standard cannot confer immunity from legal obligations.

This British Standard was published under the authority of the Standards Policy and Strategy Committee on 30 April 2015.

Amendments issued since publication

Date	Text affected
------	---------------

**Corrosion of metals and alloys — Test
method for high temperature corrosion
testing of metallic materials by
embedding in salt, ash, or other solids**

*Corrosion des métaux et alliages — Méthode d'essai pour essais
de corrosion à haute température de matériaux métalliques par
enfouissement dans du sel, des cendres ou d'autres solides*





COPYRIGHT PROTECTED DOCUMENT

© ISO 2015

All rights reserved. Unless otherwise specified, no part of this publication may be reproduced or utilized otherwise in any form or by any means, electronic or mechanical, including photocopying, or posting on the internet or an intranet, without prior written permission. Permission can be requested from either ISO at the address below or ISO's member body in the country of the requester.

ISO copyright office
Case postale 56 • CH-1211 Geneva 20
Tel. + 41 22 749 01 11
Fax + 41 22 749 09 47
E-mail copyright@iso.org
Web www.iso.org

Published in Switzerland

Contents

Page

Foreword	iv
Introduction	v
1 Scope	1
2 Normative references	1
3 Terms and definitions	2
4 Test method	2
4.1 Principle.....	2
4.2 Reagents and materials.....	2
4.2.1 Test pieces.....	2
4.2.2 Corrosive powder.....	3
4.3 Test apparatus.....	3
4.3.1 Design of apparatus.....	3
4.3.2 Temperature monitoring.....	4
4.3.3 Gas supply.....	5
4.4 Procedure.....	5
4.4.1 Preparation and placement of the test piece.....	5
4.4.2 Test environment.....	6
4.4.3 Heating method.....	6
4.4.4 Test duration.....	6
4.4.5 Cooling of test pieces.....	7
4.4.6 Discontinuous testing.....	7
4.5 Determination of mass change.....	7
4.5.1 Principle.....	7
4.5.2 Measurements prior to testing.....	7
4.5.3 Descaling prior to mass determination.....	7
4.5.4 Measurement of corrosion mass loss.....	8
5 Examination of surface and microstructure of corroded test pieces	8
6 Report	8
6.1 Matters to be described.....	8
6.1.1 Test material.....	8
6.1.2 Test piece.....	9
6.1.3 Testing environments.....	9
6.1.4 Test results.....	9
6.2 Supplementary note.....	10
Annex A (informative) Chemical and electrolytic procedures for removal of corrosion products from fully embedded test pieces	11
Bibliography	14

Foreword

ISO (the International Organization for Standardization) is a worldwide federation of national standards bodies (ISO member bodies). The work of preparing International Standards is normally carried out through ISO technical committees. Each member body interested in a subject for which a technical committee has been established has the right to be represented on that committee. International organizations, governmental and non-governmental, in liaison with ISO, also take part in the work. ISO collaborates closely with the International Electrotechnical Commission (IEC) on all matters of electrotechnical standardization.

The procedures used to develop this document and those intended for its further maintenance are described in the ISO/IEC Directives, Part 1. In particular the different approval criteria needed for the different types of ISO documents should be noted. This document was drafted in accordance with the editorial rules of the ISO/IEC Directives, Part 2 (see www.iso.org/directives).

Attention is drawn to the possibility that some of the elements of this document may be the subject of patent rights. ISO shall not be held responsible for identifying any or all such patent rights. Details of any patent rights identified during the development of the document will be in the Introduction and/or on the ISO list of patent declarations received (see www.iso.org/patents).

Any trade name used in this document is information given for the convenience of users and does not constitute an endorsement.

For an explanation on the meaning of ISO specific terms and expressions related to conformity assessment, as well as information about ISO's adherence to the WTO principles in the Technical Barriers to Trade (TBT), see the following URL: [Foreword — Supplementary information](#).

The committee responsible for this document is ISO/TC 156, *Corrosion of metals and alloys*.

Introduction

In contrast to high temperature corrosion occurring in a gaseous environment, which is covered in ISO 21608 and ISO 13573, this International Standard focuses on high temperature corrosion occurring on materials that are in direct contact with solid corrosive substances, commonly referred to as under-deposit corrosion.

This International Standard considers the case of a metallic material embedded, partially or completely, in a corrosive powder that is present in abundance and remains completely or partially in the solid state throughout high temperature exposure. Partially embedded test pieces offer the advantage of allowing investigation of corrosion at three different positions, i.e. under the powder, at the powder/gas phase interface, and in the gas phase above the corrosive powder.

The closely-related condition involving immersion in a molten salt or other liquid is described in ISO 17245, and that involving application of a surface deposit of salt, ash, or other substances in ISO 17224.

Corrosion of metals and alloys — Test method for high temperature corrosion testing of metallic materials by embedding in salt, ash, or other solids

1 Scope

This International Standard specifies the method for high temperature corrosion testing of metallic materials by embedding in a corrosive powder made up of salt, ash, and/or other solids and exposing them to high temperature in a controlled gas environment to evaluate their corrosion resistance.

Two options exist: fully embedding and partially embedding.

Fully embedding is used in cases in which a mass change measurement is required.

Partially embedding is used to investigate three potentially different interaction zones on a single test piece, i.e. the embedded part, the non-embedded part, and the gas/powder interface region. Therefore, gravimetric measurements are not appropriate and metallographic investigations are necessary instead.

This International Standard does not cover methods where test pieces are immersed in a liquid or cases in which a surface deposit is applied to the test pieces. These methods are covered in ISO 17245 and ISO 17224, respectively.

2 Normative references

The following documents, in whole or in part, are normatively referenced in this document and are indispensable for its application. For dated references, only the edition cited applies. For undated references, the latest edition of the referenced document (including any amendments) applies.

ISO 3611, *Geometrical product specifications (GPS) — Dimensional measuring equipment: Micrometers for external measurements — Design and metrological characteristics*

ISO 6906, *Vernier callipers reading to 0,02 mm*

ISO 8044, *Corrosion of metals and alloys — Basic terms and definitions*

ISO 8407:2009, *Corrosion of metals and alloys — Removal of corrosion products from corrosion test specimens*

ISO 21608:2012, *Corrosion of metals and alloys — Test method for isothermal-exposure oxidation testing under high-temperature corrosion conditions for metallic materials*

ISO 26146, *Corrosion of metals and alloys — Method for metallographic examination of samples after exposure to high-temperature corrosive environments*

ASTM E3, *Standard guide for preparation of metallographic specimens*

ASTM E220, *Standard method for calibration of thermocouples by comparison techniques*

ASTM E230, *Standard temperature-electromotive forces tables for standardized thermocouples*

ASTM E407, *Standard practice for microetching metals and alloys*

ASTM E1350, *Standard test method for testing sheathed thermocouples prior to, during and after installation*

3 Terms and definitions

For the purposes of this document, the terms and definitions given in ISO 8044 and the following apply.

3.1 affected layer
layer beneath the test piece surface that is affected in its composition and/or structure due to corrosion

3.2 corrosive powder
powder mixture made up of salt, ash, and/or other solids that contains compounds that are expected to react with the metal at high temperature

3.3 controlled gas environment
flowing gas mixture of defined composition and flow rate which can affect the behaviour of the corrosive powder

3.4 descaling
removal of corrosion products and corrosive phases from the test piece surface before measurement of the mass of the remaining metal

4 Test method

4.1 Principle

Mass change measurements can be performed with fully embedded test pieces. In this case, the test shall be performed with at least three test pieces of each material to ensure reproducibility of the test results. Two test pieces shall be used for determination of mass change or dimensional change, and one shall be used for observation of the surface and/or cross section.

4.2 Reagents and materials

4.2.1 Test pieces

Test pieces for fully embedding shall have the form of a rectangular plate, a disc, or a cylinder with a minimum surface area of 300 mm² and a minimum thickness of 1,5 mm.

Test pieces for partially embedding shall have the form of a rectangular plate with a minimum length of 60 mm and a minimum thickness of 1,5 mm. The rectangular geometry allows accurate metallographic examinations of longitudinal sections as well as transverse sections, which is not possible with a cylindrical test piece.

If the test pieces cannot be made according to these specifications, the shape and dimensions of the test pieces shall be in accordance with the agreement between the parties involved.

The test pieces shall be machined to remove the strata affected by cutting.

The final finishing of the surface of the test pieces shall be performed with abrasives with a mean particle diameter of approximately 15 µm. This can be achieved by the use of abrasives according to [Table 1](#).

Table 1 — Designation and mean diameter of particles of coated abrasives according to regional standards

Standard	Designation	Mean diameter µm	Region
FEPA ^a 43-1984 R 1993: Grit Sizes for Coated Abrasives ISO 6344 Coated abrasives — Grain size analysis	P1200	15,3 ± 1,0	Europe
JIS R6001-87	#1000	15,5 ± 1,0	Japan
ANSI B74.12-92 — Specifications for the Size of Abrasive Grain — Grinding Wheels, Polishing and General Industrial Uses	600	16,0	America
^a Federation of European Producers of Abrasives.			

If another surface finish is required by the parties involved, the surface finish condition shall be described.

Sharp edges of test pieces might give anomalous behaviour. These shall be slightly rounded during the final stages of test piece preparation.

The dimensions of the test pieces shall be measured prior to exposure at a minimum of three positions for each dimension with a precision of ±0,02 mm by means of the measuring instruments specified in ISO 3611 and ISO 6906.

After ultrasonically degreasing in isopropanol or ethanol, the test pieces shall be dried in hot air or in a desiccator.

If it is suspected that test pieces might absorb significant amounts of atmospheric contaminants such as water, it is recommended that the cleaned test pieces be stored in a desiccator prior to weighing and exposure.

4.2.2 Corrosive powder

The type of powder to be used in the test shall be selected in accordance with the environment for which the test is intended. The powder shall be prepared either by taking ash or deposit from actual equipment or by mixing chemicals of reagent grade.

The particle size of the powder shall not exceed 100 µm. When using reagent grade chemicals, the particle size (according to the supplier's specification) shall be recorded.

WARNING — When working with dangerous substances (such as certain ashes, molten salts, heavy metals, and organic materials), all necessary safety precautions shall be taken.

4.3 Test apparatus

4.3.1 Design of apparatus

The apparatus shall be composed as a whole, of the temperature-regulating device for heating all test pieces at a uniform temperature. The heating device shall be equipped with a testing portion capable of separating the test pieces from outside air. The gas supply shall be controlled by a gas flow meter.

A basic design of a closed, horizontal, apparatus is shown in [Figure 1](#). Other designs can use vertical orientation. A design of the complete furnace setup is shown in ISO 21608:2012, Figure 1.

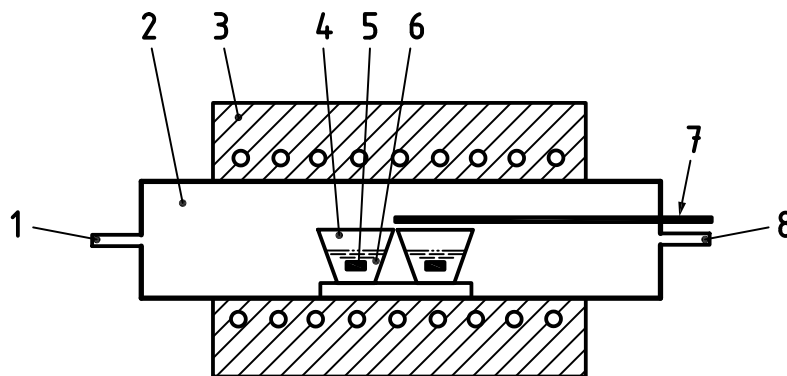

Key

- 1 test gas inlet
- 2 test chamber
- 3 heating unit
- 4 crucible
- 5 test piece
- 6 corrosive substance
- 7 thermocouple
- 8 gas exit

Figure 1 — Apparatus using a horizontal furnace

The test chamber shall not be composed of materials that react significantly with the gas environment or the corrosive substance during the test. If the reaction is not avoidable, the reaction shall be small enough to neglect a change in composition of the atmosphere.

4.3.2 Temperature monitoring

The temperature distribution of the furnace shall be characterized at the exposure temperature prior to the testing to determine the width of the isothermal zone by the use of a movable thermocouple.

The temperature-regulating device shall be capable of guaranteeing that the temperature of the test piece is kept within the permissible range given in [Table 2](#).

Table 2 — Permissible tolerance of temperature of test pieces

Temperature range, °C	≤300	300 to 600	600 to 800	800 to 1 000	1 000 to 1 200	>1 200
Temperature tolerance, °C	±2	±3	±4	±5	±7	By agreement

Thermocouple sheaths shall be used to protect the thermocouple wires and shall fully withstand the test temperature and environment.

A specimen thermocouple shall be positioned as close as possible to the test piece. If the experimental condition does not allow the use of such a thermocouple, the temperature of the test piece has to be deduced from the furnace calibration using dummy test pieces in an appropriate environment.

Calibration of thermocouples shall be performed in accordance with ASTM E220, ASTM E230, and ASTM E1350. A representative thermocouple taken from the batch of wire may be calibrated.

Thermocouples shall be recalibrated annually or at the beginning and the end of each experiment if there is uncertainty about thermocouple stability.

4.3.3 Gas supply

The gas supply system shall be capable of supplying the test gases at a constant flow rate to the test piece chamber described in [4.3.1](#).

When a humidifying regulator is used, it shall be capable of adjusting to the desired humidity. Deionized water of electrical conductivity less than $1 \mu\text{S cm}^{-1}$ shall be used.

The gas line between humidifying regulator and test chamber shall be kept above the dew point in order to avoid condensation. Condensation might have a severe impact on the result.

The gas flow shall be monitored by a gas flow meter. The flow meter shall be located as close as possible to the inlet of the test chamber except where a humidifying regulator is used, in which case, it shall be located upstream from the humidifier.

In the case that the gas is humidified, the water vapour content shall be measured. This can be achieved by e.g., the use of a hygrometer before the test chamber or by measuring the amount of water after condensation of the exhaust gases or by measuring the water consumption of the humidifier over the course of the experiment.

4.4 Procedure

4.4.1 Preparation and placement of the test piece

The crucibles shall be inert to the environment. Each crucible shall contain only one test piece.

Crucibles shall be baked in air to remove volatile compounds before their first use. The recommended baking condition is at least 24 h at a temperature of 1 000 °C. If water absorption is suspected to have occurred, used crucibles shall be dried at significantly above 100 °C.

For fully embedding tests, a layer of at least 3 mm of corrosive powder shall be put in the crucible and the top of the powder shall be flattened by applying a uniform pressure (about 0,04 MPa = 40 g/cm²).

NOTE This can be achieved by applying a flat metal piece with the appropriate mass to area ratio to the entire surface area of the powder in one or more applications.

After the test piece is set on the bed of powder, the additional powder shall be put on top of the test piece to cover it with a powder layer of at least 3 mm in thickness. Finally, the top layer shall be flattened by the procedure described above. The distance between the top of the powder and the top of the crucible shall not exceed 3 mm.

The test pieces for partially embedding tests shall be placed upright in crucibles with a height of at least the length of the test pieces and a diameter that leaves at least 5 mm on each edge of the test pieces. Corrosive powder shall be filled into the crucibles up to half the height of the test pieces and its top layer shall be flattened by the procedure described above.

The configuration of fully embedded and partially embedded test pieces in crucibles is shown in [Figure 2](#).

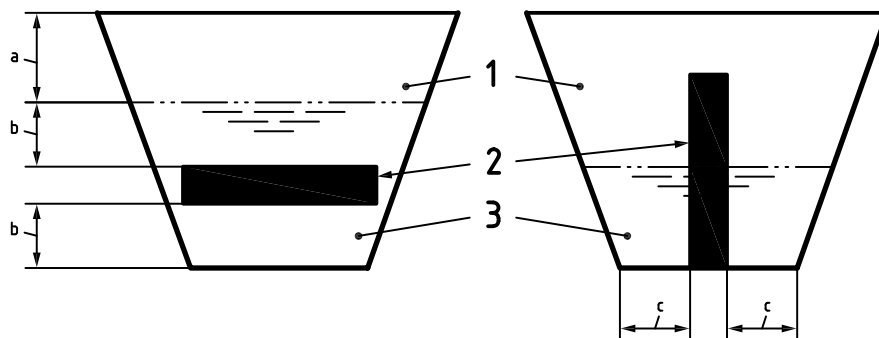

Key

- 1 crucible
- 2 test piece
- 3 corrosive powder
- a Max. 3 mm.
- b Min. 3 mm.
- c Min. 5 mm.

NOTE Left = fully embedding tests; right = partially embedding tests.

Figure 2 — Test piece fully embedded and partially embedded in corrosive powder

4.4.2 Test environment

The composition of the test gas shall be chosen in a way that it keeps the corrosive activity of the corrosive powder stable.

The flow rate of the test gas shall be sufficient as to fill the test chamber at least three times per hour. This is to ensure that the corrosion rate is not determined by the supply of the reactants.

The gas flow shall be preheated to reach equilibrium in the gas phase. An appropriate catalyst shall be used, if necessary.

4.4.3 Heating method

The test pieces in their crucibles shall be placed in the furnace either at room temperature or at the test temperature, by agreement between the parties. In the former case, the time to reach the test temperature shall be recorded.

Where test pieces are loaded into a cold furnace, heating shall be carried out in the test gas. In the case of humidified atmospheres, the humidification shall not be started until the temperature in the coldest part of the test chamber exceeds the dew point of possible condensing phases.

If heating in the test gas is not acceptable from a safety perspective, heating shall be performed in a gas similar in composition to the test gas but with the critical components absent until a temperature has been reached and at which point, the safety concerns have been resolved. Where test pieces are loaded into a hot furnace, a flow of inert gas can be used during the loading procedure.

The heating shall be carried out in a manner that the temperature of test pieces does not exceed the upper limit of permissible range listed in [Table 2](#).

4.4.4 Test duration

The test is defined to commence when the test piece temperature exceeds 97 % of the desired test temperature, T_{dwell} (measured in K).

The test ends when the temperature of the test piece falls below 97 % of the desired test temperature, T_{dwell} (measured in K).

The test duration shall be relevant to the intended application and agreed upon between the parties concerned. The materials' behaviour, observed in short-term exposures, might not continue at long durations. Therefore, for testing of relevance to long-term service conditions, the entire exposure time shall be at least 300 h.

4.4.5 Cooling of test pieces

If furnace cooling is used, it shall be carried out in the test gas down to 200 °C and the time to cool down to 50 °C shall be recorded. The test pieces can also be removed from the furnace at test temperature. A dry purge gas atmosphere shall be applied for a sufficient duration before removing the test pieces from the furnace. In the case of humidified atmospheres, the humidification shall be stopped before the temperature in the coldest part of the test chamber falls below 200 °C.

If cooling in the test gas is not acceptable from a safety perspective, cooling shall be performed in a gas similar in composition to the test gas but with the critical components absent.

4.4.6 Discontinuous testing

For discontinuous exposure, the same heating methods (see [4.4.3](#)) and cooling methods (see [4.4.5](#)) shall be applied each time the test pieces are reloaded for continued exposure.

Each time before the test pieces are reloaded, the corrosive powder shall be completely replaced. If the corrosive powder cannot be completely replaced without damage to the samples, replacement shall be in accordance with the agreement between the parties involved.

4.5 Determination of mass change

4.5.1 Principle

One method to determine corrosion kinetics is to measure mass change. This is possible only with fully embedded test pieces, and only if the corrosive powder can be removed completely after testing. Duplicate test pieces of each material shall be used. Test pieces should be weighed as soon as possible or shall be stored in a desiccator after removal from the furnace until immediately before weighing. When handling test pieces, tweezers shall be used. Test pieces shall never be touched with the hands to avoid contamination (e.g., grease, salts). Care has to be taken when using gloves as the contamination with the separating agent of the gloves leads to falsification in mass determination. If repeated measurements are not consistent, the temperature and humidity of the weighing environment has to be controlled.

4.5.2 Measurements prior to testing

The mass of the test pieces shall be determined prior to exposure [$m_T(t_0)$, in ISO 21608:2012, Figure 5]. At least two individual measurements shall be made for each test piece with a precision of 0,02 mg. The maximum difference between the measurements shall not exceed $\pm 0,05$ mg.

4.5.3 Descaling prior to mass determination

If descaling prior to mass determination is intended, all corrosion products shall be removed from test pieces with a minimum removal of sound metal. This shall be done according to ISO 8407.

Additional procedures are given in [Annex A](#) (see [Table A.1](#) and [Table A.2](#)).

After descaling, the test pieces shall not be used for further corrosion testing.

NOTE These procedures are not suitable to remove internal corrosion products as defined in ISO 26146.

4.5.4 Measurement of corrosion mass loss

The mass loss of the test pieces due to corrosion shall be determined according to ISO 8407.

5 Examination of surface and microstructure of corroded test pieces

Metallographic examination shall be made on the surface and cross section of fully embedded test pieces.

The metallographic examination of partially embedded test pieces serves the purpose of characterizing three potentially different zones on a single test piece (i.e. the embedded part, the non-embedded part, and the gas/powder interface region). Metallographic examination shall be made of the surface in plain view, of a longitudinal section, and, if required, of at least two transverse sections representing the embedded and the non-embedded zones (see [Figure 3](#)).

Detailed procedures for examination are provided in ISO 26146.

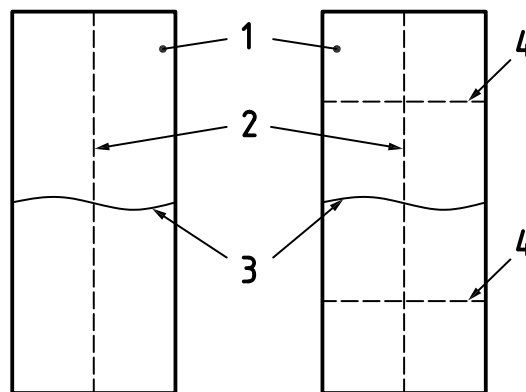

Key

- 1 test piece
- 2 longitudinal section
- 3 gas/powder interface
- 4 transverse sections

Figure 3 — Two examples of preparation of test pieces for metallographic examination

6 Report

6.1 Matters to be described

The following data, where known, shall be included in the report on the test results.

6.1.1 Test material

- a) Manufacturer
- b) Name of material (Manufacturer designation; ASTM, DIN, etc.)
- c) Grade or symbol
- d) Heat number/Batch number
- e) Chemical composition (analysis technique)
- f) Processing condition

- g) Heat treatment condition
- h) Microstructure of the material determined according to ASTM E3 and etching according to ASTM E407

6.1.2 Test piece

- a) Designation of test piece
- b) Sampling conditions of the test piece from raw material (Crystallographic orientation, rolling direction, etc.)
- c) Dimensions (in mm) and surface area, A , (in cm^2) of test piece
- d) Surface finish condition of test piece
- e) Degreasing method of test piece
- f) Initial mass of fully embedded test piece for mass change measurement

6.1.3 Testing environments

- a) Test temperature
- b) Characteristic heating and cooling curves of the test piece in the powder
- c) Test duration
- d) Volume of test chamber
- e) Composition of test gas, including humidity
- f) Volumetric flow rate of test gas in normal cubic metres per second
- g) Chemical composition, particle size distribution (if available), and origin of the corrosive powder
- h) Amount of corrosive powder used per crucible
- i) Size, type, and material of the crucibles used

6.1.4 Test results

- a) Mass loss of fully embedded test pieces caused by descaling procedures, according to [4.5.3](#)
- b) Mass loss of fully embedded test pieces caused by the corrosion experiment, according to [4.5.4](#)
- c) In case of determination of corrosion kinetics: mass loss of fully embedded test pieces, Δm , divided by surface area, A , as a function of time
- d) Image of appearance after testing
- e) Image of cross sections, including the surface layer of the metallographic section of test piece after testing (the chosen magnifications shall clearly show the extent of the total attack in a single micrograph)
- f) Thickness profile of unaffected metal along the longitudinal section of partially embedded test pieces
- g) Minimum thickness of unaffected metal in each zone of partially embedded test pieces
- h) Results of any other metallographic investigations performed according to [Clause 5](#)
- i) Results of analysis of corrosive powder after long-term exposure, if performed, according to [4.2.2](#)

6.2 Supplementary note

It is desirable to additionally describe the following matters in the report on the test results:

- a) mechanical properties of the initial material;
- b) microstructure of the initial material and sampling conditions;
- c) further details of the test apparatus;
- d) characteristics of the corrosive powder determined by differential thermal analysis and thermogravimetry, if available.

Annex A (informative)

Chemical and electrolytic procedures for removal of corrosion products from fully embedded test pieces

A.1 General

In the development of this International Standard, a number of sources were consulted to identify chemical and electrolytic descaling procedures. They can be used in addition to those listed in ISO 8407, and they are specifically designed for the purpose of the tests described in this International Standard. This Annex summarizes the results of the survey.

Prior to adopting these procedures, the user should conduct a test on control test pieces to ensure the efficiency of the chosen method. Excess descaling might result in dissolution not only of corrosion products but also of metal substrates.

A.2 Procedures

[Table A.1](#) and [Table A.2](#) summarize various chemical and electrolytic procedures for removal of corrosion products. The specific choice of procedure for a given material will depend on many factors, including previous experience.

For all the procedures listed, it is recommended that the surfaces should be maintained vertical during cleaning. This will minimize retention of any gases released during the procedure.

The times specified represent recommendations appropriate for mass-loss studies in the context of ISO 8407:2009, Figure 1.

When using electrolytic procedures, selecting adequate electrolysis parameters and using blank specimens is recommended, in order to ensure precise removal of corrosion products. A typical setup is shown in [Figure A.1](#).

WARNING — When working with dangerous substances (such as sodium hydroxide, potassium permanganate, hydrochloric acid, and molten salts), all necessary safety precautions shall be taken.

Table A.1 — Chemical procedures for removal of corrosion products

Designation	Material	Chemical agents	Total time	Temperature	Remarks
C.7.10	Heat-resistant stainless steels and superalloys	Step 1: 180 g of sodium hydroxide (NaOH) 30 g of potassium permanganate (KMnO ₄) Distilled water to make 1 000 ml	30 min to 40 min	boiling	Repetition of step 1/ step 2/ washing is effective for sticky corrosion products
		Step 2: 100 g of ammonium citrate ((NH ₄) ₂ C ₆ H ₆ O ₇) Distilled water to make 1 000 ml	30 min to 40 min	boiling	Brushing by soft brush in the middle of treatment is effective
C.3.4	Carbon steels and low-alloy steels	50 ml of hydrochloric acid (HCl, ρ = 1,19 g/ml) 0,5 g of hexamethylenetetramine or of 1,3-di- <i>n</i> -butyl-2-thiourea Distilled water to make 1 000 ml	30 min to 40 min	60 °C	Repetition of acid cleaning/ washing is effective for sticky corrosion products

Table A.2 — Electrolytic procedures for removal of corrosion products

Designation	Material	Chemical agents	Total time	Temperature	Remarks
E.5.1	Heat-resistant stainless steels and superalloys	Molten salt containing mass fractions of 40 % of sodium hydroxide (NaOH) and 60 % of sodium carbonate (Na ₂ CO ₃)	2 min to 5 min	500 °C to 650 °C	Current density of 0,3 to 1,0 A/cm ² Repetition of electrolysis and washing is effective for sticky scale Brushing by soft brush in the middle of washing is effective Optimization of electrolysis is important

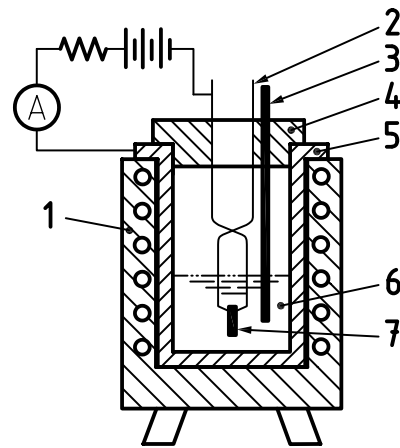

Key

- 1 electric furnace
- 2 specimen holder
- 3 thermocouple
- 4 refractory material
- 5 electrolytic bath
- 6 molten salt
- 7 specimen

Figure A.1 — Typical equipment for the method E.5.1

Bibliography

- [1] ISO 13573, *Corrosion of metals and alloys — Test method for thermal-cycling exposure testing under high-temperature corrosion conditions for metallic materials*
- [2] ISO 17224, *Corrosion of metals and alloys — Test method for high temperature corrosion testing of metallic materials by application of a deposit of salt, ash, or other substances*
- [3] ISO 17245, *Corrosion of metals and alloys — Test method for high temperature corrosion testing of metallic materials by immersing in molten salt or other liquids*
- [4] JIS Z2290-2004, *General rules for high-temperature corrosion test of metallic materials*
- [5] JIS Z2293-2004, *Methods for high-temperature corrosion test of metallic materials by dipping and embedding in molten salts*

British Standards Institution (BSI)

BSI is the national body responsible for preparing British Standards and other standards-related publications, information and services.

BSI is incorporated by Royal Charter. British Standards and other standardization products are published by BSI Standards Limited.

About us

We bring together business, industry, government, consumers, innovators and others to shape their combined experience and expertise into standards-based solutions.

The knowledge embodied in our standards has been carefully assembled in a dependable format and refined through our open consultation process. Organizations of all sizes and across all sectors choose standards to help them achieve their goals.

Information on standards

We can provide you with the knowledge that your organization needs to succeed. Find out more about British Standards by visiting our website at bsigroup.com/standards or contacting our Customer Services team or Knowledge Centre.

Buying standards

You can buy and download PDF versions of BSI publications, including British and adopted European and international standards, through our website at bsigroup.com/shop, where hard copies can also be purchased.

If you need international and foreign standards from other Standards Development Organizations, hard copies can be ordered from our Customer Services team.

Subscriptions

Our range of subscription services are designed to make using standards easier for you. For further information on our subscription products go to bsigroup.com/subscriptions.

With **British Standards Online (BSOL)** you'll have instant access to over 55,000 British and adopted European and international standards from your desktop. It's available 24/7 and is refreshed daily so you'll always be up to date.

You can keep in touch with standards developments and receive substantial discounts on the purchase price of standards, both in single copy and subscription format, by becoming a **BSI Subscribing Member**.

PLUS is an updating service exclusive to BSI Subscribing Members. You will automatically receive the latest hard copy of your standards when they're revised or replaced.

To find out more about becoming a BSI Subscribing Member and the benefits of membership, please visit bsigroup.com/shop.

With a **Multi-User Network Licence (MUNL)** you are able to host standards publications on your intranet. Licences can cover as few or as many users as you wish. With updates supplied as soon as they're available, you can be sure your documentation is current. For further information, email bsmusales@bsigroup.com.

BSI Group Headquarters

389 Chiswick High Road London W4 4AL UK

Revisions

Our British Standards and other publications are updated by amendment or revision.

We continually improve the quality of our products and services to benefit your business. If you find an inaccuracy or ambiguity within a British Standard or other BSI publication please inform the Knowledge Centre.

Copyright

All the data, software and documentation set out in all British Standards and other BSI publications are the property of and copyrighted by BSI, or some person or entity that owns copyright in the information used (such as the international standardization bodies) and has formally licensed such information to BSI for commercial publication and use. Except as permitted under the Copyright, Designs and Patents Act 1988 no extract may be reproduced, stored in a retrieval system or transmitted in any form or by any means – electronic, photocopying, recording or otherwise – without prior written permission from BSI. Details and advice can be obtained from the Copyright & Licensing Department.

Useful Contacts:

Customer Services

Tel: +44 845 086 9001

Email (orders): orders@bsigroup.com

Email (enquiries): cservices@bsigroup.com

Subscriptions

Tel: +44 845 086 9001

Email: subscriptions@bsigroup.com

Knowledge Centre

Tel: +44 20 8996 7004

Email: knowledgecentre@bsigroup.com

Copyright & Licensing

Tel: +44 20 8996 7070

Email: copyright@bsigroup.com



...making excellence a habit.™