

BS ISO 17178:2013



BSI Standards Publication

Adhesives — Adhesives for bonding parquet to subfloor — Test methods and minimum requirements

bsi.

...making excellence a habit.™

National foreword

This British Standard is the UK implementation of ISO 17178:2013.

The UK participation in its preparation was entrusted to Technical Committee PRI/52, Adhesives.

A list of organizations represented on this committee can be obtained on request to its secretary.

This publication does not purport to include all the necessary provisions of a contract. Users are responsible for its correct application.

© The British Standards Institution 2013. Published by BSI Standards Limited 2013

ISBN 978 0 580 75687 0

ICS 83.180

Compliance with a British Standard cannot confer immunity from legal obligations.

This British Standard was published under the authority of the Standards Policy and Strategy Committee on 31 May 2013.

Amendments issued since publication

Date	Text affected
------	---------------

INTERNATIONAL
STANDARD

BS ISO 17178:2013

ISO
17178

First edition
2013-04-15

**Adhesives — Adhesives for bonding
parquet to subfloor — Test methods
and minimum requirements**

*Adhésifs — Adhésifs pour le collage de parquet au sol — Méthodes
d'essai et exigences minimales*



Reference number
ISO 17178:2013(E)

© ISO 2013



COPYRIGHT PROTECTED DOCUMENT

© ISO 2013

All rights reserved. Unless otherwise specified, no part of this publication may be reproduced or utilized otherwise in any form or by any means, electronic or mechanical, including photocopying, or posting on the internet or an intranet, without prior written permission. Permission can be requested from either ISO at the address below or ISO's member body in the country of the requester.

ISO copyright office
Case postale 56 • CH-1211 Geneva 20
Tel. + 41 22 749 01 11
Fax + 41 22 749 09 47
E-mail copyright@iso.org
Web www.iso.org

Published in Switzerland

Contents

	Page
Foreword	iv
1 Scope	1
2 Normative references	1
3 Terms and definitions	1
4 Test methods and procedures	2
4.1 Sampling and test conditions.....	2
4.2 Test method for determining shear strength.....	2
4.3 Test method for the determination of tensile strength.....	4
4.4 Test method for determining shear strength of hard elastic and elastic adhesives.....	6
5 Test report	9
6 Minimum requirements	9

Foreword

ISO (the International Organization for Standardization) is a worldwide federation of national standards bodies (ISO member bodies). The work of preparing International Standards is normally carried out through ISO technical committees. Each member body interested in a subject for which a technical committee has been established has the right to be represented on that committee. International organizations, governmental and non-governmental, in liaison with ISO, also take part in the work. ISO collaborates closely with the International Electrotechnical Commission (IEC) on all matters of electrotechnical standardization.

The procedures used to develop this document and those intended for its further maintenance are described in the ISO/IEC Directives, Part 1. In particular the different approval criteria needed for the different types of ISO documents should be noted. This document was drafted in accordance with the editorial rules of the ISO/IEC Directives, Part 2. www.iso.org/directives

Attention is drawn to the possibility that some of the elements of this document may be the subject of patent rights. ISO shall not be held responsible for identifying any or all such patent rights. Details of any patent rights identified during the development of the document will be in the Introduction and/or on the ISO list of patent declarations received. www.iso.org/patents

Any trade name used in this document is information given for the convenience of users and does not constitute an endorsement.

The committee responsible for this document is ISO/TC 61, *Plastics*, Subcommittee SC 11, *Products*.

Adhesives — Adhesives for bonding parquet to subfloor — Test methods and minimum requirements

SAFETY STATEMENT — Persons using this document should be familiar with the normal laboratory practice. This document does not purport to address all of the safety problems, if any, associated with its use. It is the responsibility of the user to establish appropriate safety and health practices and to ensure compliance with any regulatory conditions.

1 Scope

This International Standard specifies test methods for adhesives for bonding parquet and similar wood floorings to a subfloor. It also specifies the minimum requirements for shear strength, tensile strength to be achieved with these adhesives.

This International Standard does not refer to the selection and installation of parquet floorings.

2 Normative references

The following documents, in whole or in part, are normatively referenced in this document and are indispensable for its application. For dated references, only the edition cited applies. For undated references, the latest edition of the referenced document (including any amendments) applies.

ISO 554, *Standard atmospheres for conditioning and/or testing — Specifications*

ISO 10365, *Adhesives — Designation of main failure patterns*

ISO 15605, *Adhesives — Sampling*

EN 923:2005, *Adhesives — Terms and definitions*

EN 1067, *Adhesives — Examination and preparation of samples for testing*

EN 1323, *Adhesives for tiles — Concrete slab for test*

EN 13488, *Wood flooring — Mosaic parquet elements*

3 Terms and definitions

For the purposes of this document, the terms and definitions given in EN 923:2005 and the following apply.

3.1

hard adhesive

adhesive which shows a shear strength of 3,0 N/mm² or more

Note 1 to entry: Hard adhesives are tested according to [4.2](#).

3.2

hard elastic adhesive

adhesive which shows a shear strength of 2,0 N/mm² or more and a shear elongation of 0,5 or more

Note 1 to entry: Hard elastic adhesives are tested according to [4.4](#).

3.3 elastic adhesive

adhesive which shows a shear strength between 1,0 N/mm² and 2,0 N/mm² and a shear elongation of 1,0 or more

Note 1 to entry: Elastic adhesives are tested according to [4.4](#).

3.4 shear elongation

deformation of the unit thickness of an adhesive under a shear force

4 Test methods and procedures

4.1 Sampling and test conditions

Take the adhesive sample to be tested in accordance with ISO 15605 and examine and prepare it for testing in accordance with EN 1067.

All test methods shall be carried out under standard conditions at (23 ± 2) °C and at (50 ± 5) % relative air humidity in accordance with ISO 554. Condition all test materials for at least 24 h under standard conditions.

The shape of the notches shall be triangular for all notched trowels (see [Figure 1](#)).

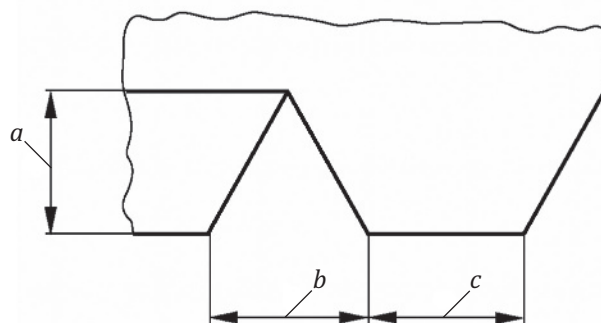

Key

- a* notch depth
- b* notch width
- c* notch distance

Figure 1 — Shape of notches of notched trowels

4.2 Test method for determining shear strength

4.2.1 Principle

Two mosaic parquet fingers are lap bonded and stored under two different conditions. After conditioning, the test specimens are clamped in a tensile testing machine and an increasing deformation is applied until breakage.

The shear strength is then calculated.

4.2.2 Material

4.2.2.1 Mosaic parquet finger according to EN 13488, oak with dimensions of (160 ± 5) mm \times (23 ± 1) mm \times $(8,0 \pm 0,3)$ mm.

4.2.2.2 Sample of adhesive, for testing.

4.2.3 Apparatus

4.2.3.1 Notched trowel (for the shape of the notch, see [Figure 1](#)), dimensions as follows:

- notch depth: $a = (3,25 \pm 0,10)$ mm;
- notch width: $b = (3,70 \pm 0,10)$ mm;
- notch distance: $c = (3,30 \pm 0,10)$ mm.

4.2.3.2 Weights, 2 kg \pm 10 g mass each.

4.2.3.3 Timer, accuracy 1 s.

4.2.3.4 Tensile testing machine, with a transverse rate of (20 ± 2) mm/min and a maximum force of 5 kN to 10 kN.

4.2.3.5 Oven, air circulating oven capable of controlling the temperature to within ± 2 °C.

4.2.4 Preparation of test specimens

With the trowel held vertically, spread the adhesive on one end of the mosaic parquet finger, so that an area of (800 ± 200) mm² is wetted. The ribs of the adhesive shall be nearly at right angles to the length of the mosaic parquet finger. Immediately, or after a waiting time as required by the adhesive manufacturer, form the single test specimen by pressing a second mosaic parquet finger on every prepared finger.

The overlap bond area shall be (600 ± 20) mm². The fingers shall be parallel. Every bond shall be loaded with a weight of 2 kg for 60 s.

Store two groups of test specimens free of tension as follows:

- a) 10 test specimens for 3 days at standard conditions 23/50 in accordance with ISO 554.
- b) 10 test specimens for a total of 28 days, in detail:
 - 1) seven days at standard conditions 23/50 in accordance with ISO 554;
 - 2) 20 days at (40 ± 2) °C;
 - 3) one day at standard conditions 23/50 in accordance with ISO 554.

4.2.5 Test procedure and evaluation of test results

After conditioning, clamp the ends of the test specimen in the jaws of the tensile testing machine. The lengths between the jaws shall be (200 ± 20) mm. Ensure that the force is applied centrally and in the plane of the bond. Load the test specimen until breakage. Determine the maximum force F_{\max} in N.

The shear strength T_S (in N/mm²) is calculated to an accuracy of $\pm 0,1$ N/mm² by Formula (1):

$$T_S = \frac{F_{\max}}{A} \quad (1)$$

where

F_{\max} is the maximum force, in N;

A is the bonded area, in mm².

4.3 Test method for the determination of tensile strength

4.3.1 Principle

Wood parquet pieces are bonded with an adhesive to a concrete slab. After storing under standard conditions for different time intervals, the tensile strength is determined using bonded pull head plates.

4.3.2 Material

4.3.2.1 **Sample of adhesive**, for testing.

4.3.2.2 **Parquet pieces** with dimensions of (50 ± 5) mm \times (50 ± 5) mm \times (approximately 10 mm).

4.3.2.3 **Concrete slab**, standard concrete slab in accordance with EN 1323.

4.3.2.4 **Adhesive** for bonding the pull head plates.

4.3.3 Apparatus

4.3.3.1 **Notched trowel** (for the shape of the notch, see [Figure 1](#)), dimensions as follows:

- notch depth: $a = (3,25 \pm 0,10)$ mm;
- notch width: $b = (3,70 \pm 0,10)$ mm;
- notch distance: $c = (3,30 \pm 0,10)$ mm.

4.3.3.2 **Weights**, 2 kg \pm 10 g mass each.

4.3.3.3 **Pull head plates**, square metal plates with dimensions of (50 ± 1) mm \times (50 ± 1) mm and a minimum thickness of 10 mm with a suitable fitting for connecting them to the testing machine.

4.3.3.4 **Tensile testing machine**, with a suitable capacity and accuracy for the test. The machine shall be capable of applying the load to the pullhead plate at a rate of (250 ± 50) N/s through a suitable fitting that does not exert any bending force.

4.3.3.5 **Oven**, air circulating oven capable of controlling the temperature within ± 2 °C.

4.3.4 Preparation of test specimens

Pour about 300 g of the adhesive onto the concrete slab. Then, using the notched trowel held at an angle of approximately 60 ° to the slab, comb the adhesive to provide a uniform application. Hold the trowel at a right angle to one edge of the slab and draw it across the slab parallel to that edge in a straight line.

After a time recommended by the adhesive manufacturer, place at least 10 parquet pieces on the adhesive at a distance of approximately 50 mm apart and load each bonded parquet piece immediately with a weight of 2 kg for 60 s.

4.3.5 Test procedure

4.3.5.1 Determination of tensile strength after seven days

Prepare the test specimens in accordance with [4.3.4](#) and store them under standard conditions ([4.1](#)).

After six days, bond the pull head plates nearly flush to the parquet pieces with a suitably high strength adhesive (e.g. epoxide resin).

After a further 24 h storage under standard conditions ([4.1](#)), determine the tensile strength by applying a force at a constant rate of (250 ± 50) N/s until breakage.

Record the maximum force in N. Calculate the tensile strength according to [4.3.6](#).

4.3.5.2 Determination of tensile strength after 28 days

Prepare the test specimens in accordance with [4.3.4](#) and store them under standard conditions ([4.1](#)).

After 27 days, bond the pull head plates nearly flush to the parquet pieces with a suitably high strength adhesive (e.g. epoxide resin).

After a further 24 h storage under standard conditions ([4.1](#)), determine the tensile strength by applying a force at a constant rate of (250 ± 50) N/s until breakage.

Record the maximum force in N. Calculate the tensile strength according to [4.3.6](#).

4.3.5.3 Determination of tensile strength after heat ageing

Prepare the test specimens in accordance with [4.3.4](#).

Condition the test specimens under standard conditions ([4.1](#)) for seven days and place them in an air-circulating oven at (40 ± 2) °C for a further 20 days. Remove the test specimens from the oven and bond the pull head plates nearly flush to the parquet pieces with a suitable high strength adhesive (e.g. epoxide resin).

Condition the test specimens for a further 24 h under standard conditions ([4.1](#)). Then apply a force under constant rate of (250 ± 50) N/s until breakage. Record the maximum force in N. Calculate the tensile strength according to [4.3.6](#).

4.3.6 Evaluation and expression of test results

The tensile adhesive strength, T_T (in N/mm²), is calculated using Formula (2) and reported with an accuracy of $\pm 0,1$ N/mm².

$$T_T = \frac{F_{\max}}{A} \quad (2)$$

where

F_{\max} is the maximum force, in N;

A is the bonded area, in mm² (2 500 mm²).

The tensile strength for each set of conditions is determined as follows:

Calculate the arithmetic mean of the 10 results. If one or more of the values differs more than 20 % from the arithmetic mean, discard the value which differs most and recalculate the mean.

If necessary repeat this procedure. If less than five values remain, the whole test shall be repeated. Record the results of the 10 test specimens, the final arithmetic mean and the number of test results used.

The failure mode is inspected to determine the type of failure whether it is adhesive or cohesive in accordance with ISO 10365.

4.4 Test method for determining shear strength of hard elastic and elastic adhesives

4.4.1 Principle

For determining shear strength of elastic adhesives two mosaic parquet finger are lap bonded with the thickness of the adhesive gap being approximately 1 mm. After conditioning, the test specimens are clamped in a tensile testing machine and a deformation is applied until breakage. The maximum force F_{\max} is recorded. Using the thickness of the adhesive gap before testing and the elongation at maximum shear strength, the shear elongation is determined.

4.4.2 Material

4.4.2.1 Mosaic parquet finger according to EN 13488, oak with dimensions of (160 ± 5) mm \times (23 ± 1) mm \times $(8,0 \pm 0,3)$ mm.

4.4.2.2 Sample of adhesive, for testing

4.4.3 Apparatus

4.4.3.1 Template, for preparing the test specimen with an adhesive gap of approximately 1 mm (see [Figure 2](#)), made of plastic or another material, from which dried adhesive residues can be removed easily.

4.4.3.2 Tensile testing machine with a transverse rate of (20 ± 2) mm/min and a maximum force of 5 kN to 10 kN.

4.4.3.3 Micrometer or slip gauge, with an accuracy of $\pm 0,1$ mm.

4.4.3.4 Flat spatula.

4.4.4 Preparation of test specimens

Spread the adhesive on one end of a mosaic parquet finger by means of a spatula or similar tool so that an area of approximately 650 mm² is covered and the thickness of the adhesive layer is more than 1 mm. Place the finger onto the lower level of the template as shown in [Figure 2](#). Immediately, or after a waiting time as required by the adhesive manufacturer, place a second mosaic parquet finger on the upper level of the template, touching the adhesive layer of the lower finger on a bonding area of (600 ± 20) mm² and forming an adhesive gap of (1,0 ± 0,3) mm between both fingers.

Ten specimens shall be prepared this way, placed on the same template with sufficient distance between each other. The test specimens should remain on the template for at least 24 h. Afterwards, take the specimens off the template and remove any excessive adhesive without disturbing the relative position of the parquet fingers. Instead of the template, any other device or method may be used which guarantees the specified adhesive gap and the specified bonding area.

Store the specimens as follows:

- a) 10 test specimens for three days at standard conditions 23/50 in accordance with ISO 554;
- b) 10 test specimens for a total of 28 days, in detail:
 - 1) seven days at standard conditions 23/50 in accordance with ISO 554;
 - 2) 20 days at (40 ± 2) °C;
 - 3) one day at standard conditions 23/50 in accordance with ISO 554.

Dimensions in millimetres

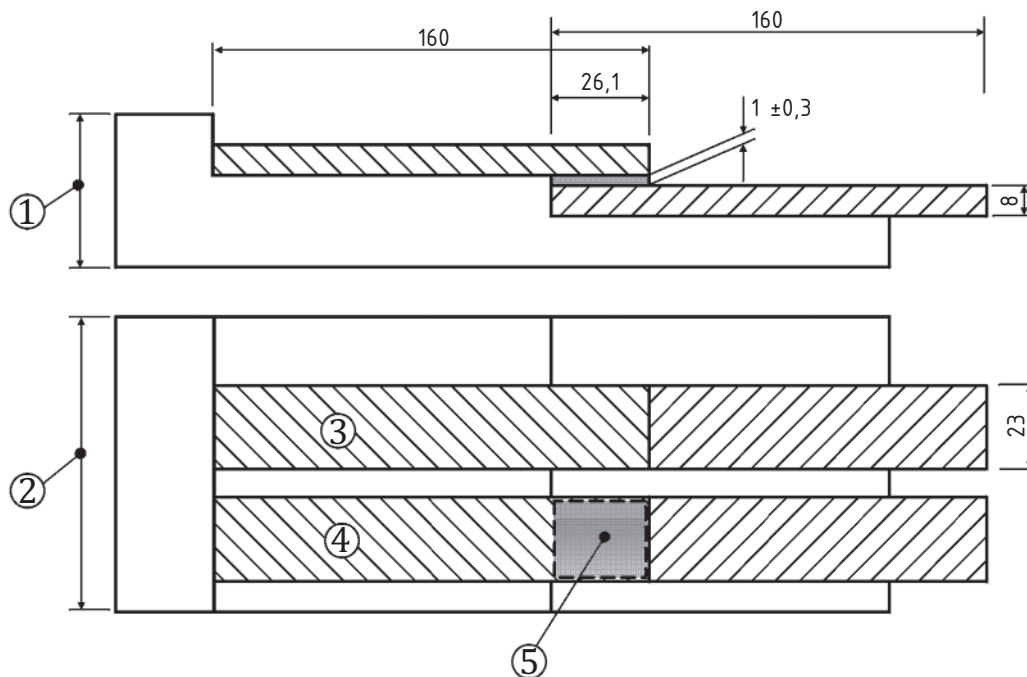

Key

- 1 any suitable height
- 2 length variable for any number of specimens
- 3 specimen 1
- 4 specimen 2
- 5 bonding area of 600 mm²

Figure 2 — Example for template and specimen

4.4.5 Test procedure and evaluation of test results

Determine the thickness, d , of the adhesive gap using a suitable micrometer or slip gauge with an accuracy of $\pm 0,1$ mm.

Perform the test procedure and the evaluation of the test results according to 4.2.5. Further, determine F_{\max} and the elongation D_{\max} at F_{\max} in mm.

The shear strength, T_S (in N/mm²) is calculated to an accuracy of $\pm 0,1$ N/mm² by Formula (3):

$$T_S = \frac{F_{\max}}{A} \tag{3}$$

where

- F_{\max} is the maximum force, in N;
- A is the bonded area, in mm².

The shear elongation γ is calculated to an accuracy of $\pm 0,1$ by Formula (4):

$$\gamma = \frac{D_{\max}}{d} \quad (4)$$

where

D_{\max} is the elongation at F_{\max} , in mm;

d is the thickness of the adhesive gap, in mm.

Calculate the arithmetic mean of the tensile shear strength values, T_S and the shear elongation values γ .

5 Test report

The test report shall include:

- a) reference to this International Standard (i.e. ISO 17178);
- b) designations of the adhesive and the adhesive batch number;
- c) type of mosaic parquet finger used;
- d) number of specimens tested;
- e) storing conditions used;
- f) notched trowel used;
- g) shear strength according to [4.2](#) or [4.4](#) or tensile strength according to [4.3](#) together with the method of test, shear or tensile;
- h) shear elongation in accordance with [4.4](#);
- i) any physical changes or abnormalities observed during the tests;
- j) any factors that have affected the test results;
- k) date of test.

6 Minimum requirements

The minimum requirements for shear strength according to [4.2](#), tensile strength according to [4.3](#) and shear strength of hard elastic or elastic adhesives according to [4.4](#) are specified in [Table 1](#).

Adhesives tested according to this International Standard shall pass at least one of the test methods [4.2](#), [4.3](#) or [4.4](#) and to fulfil the minimum requirements specified for this test in [Table 1](#).

Table 1 — Minimum requirements

Test method	Minimum requirement
4.2 Shear strength for hard adhesives for all storages conditions according 4.2.4	3,0 N/mm ²
4.3 Tensile strength for all storages conditions according 4.3.5	1,0 N/mm ²
4.4 Shear Strength for hard elastic adhesives Shear elongation γ for hard elastic adhesives for all storages conditions according 4.4.4	2,0 N/mm ² 0,5
4.4 Shear Strength for elastic adhesives Shear elongation γ for elastic adhesives for all storages conditions according 4.4.4	1,0 N/mm ² 1,0

British Standards Institution (BSI)

BSI is the national body responsible for preparing British Standards and other standards-related publications, information and services.

BSI is incorporated by Royal Charter. British Standards and other standardization products are published by BSI Standards Limited.

About us

We bring together business, industry, government, consumers, innovators and others to shape their combined experience and expertise into standards-based solutions.

The knowledge embodied in our standards has been carefully assembled in a dependable format and refined through our open consultation process. Organizations of all sizes and across all sectors choose standards to help them achieve their goals.

Information on standards

We can provide you with the knowledge that your organization needs to succeed. Find out more about British Standards by visiting our website at bsigroup.com/standards or contacting our Customer Services team or Knowledge Centre.

Buying standards

You can buy and download PDF versions of BSI publications, including British and adopted European and international standards, through our website at bsigroup.com/shop, where hard copies can also be purchased.

If you need international and foreign standards from other Standards Development Organizations, hard copies can be ordered from our Customer Services team.

Subscriptions

Our range of subscription services are designed to make using standards easier for you. For further information on our subscription products go to bsigroup.com/subscriptions.

With **British Standards Online (BSOL)** you'll have instant access to over 55,000 British and adopted European and international standards from your desktop. It's available 24/7 and is refreshed daily so you'll always be up to date.

You can keep in touch with standards developments and receive substantial discounts on the purchase price of standards, both in single copy and subscription format, by becoming a **BSI Subscribing Member**.

PLUS is an updating service exclusive to BSI Subscribing Members. You will automatically receive the latest hard copy of your standards when they're revised or replaced.

To find out more about becoming a BSI Subscribing Member and the benefits of membership, please visit bsigroup.com/shop.

With a **Multi-User Network Licence (MUNL)** you are able to host standards publications on your intranet. Licences can cover as few or as many users as you wish. With updates supplied as soon as they're available, you can be sure your documentation is current. For further information, email bsmusales@bsigroup.com.

BSI Group Headquarters

389 Chiswick High Road London W4 4AL UK

Revisions

Our British Standards and other publications are updated by amendment or revision.

We continually improve the quality of our products and services to benefit your business. If you find an inaccuracy or ambiguity within a British Standard or other BSI publication please inform the Knowledge Centre.

Copyright

All the data, software and documentation set out in all British Standards and other BSI publications are the property of and copyrighted by BSI, or some person or entity that owns copyright in the information used (such as the international standardization bodies) and has formally licensed such information to BSI for commercial publication and use. Except as permitted under the Copyright, Designs and Patents Act 1988 no extract may be reproduced, stored in a retrieval system or transmitted in any form or by any means – electronic, photocopying, recording or otherwise – without prior written permission from BSI. Details and advice can be obtained from the Copyright & Licensing Department.

Useful Contacts:

Customer Services

Tel: +44 845 086 9001

Email (orders): orders@bsigroup.com

Email (enquiries): cservices@bsigroup.com

Subscriptions

Tel: +44 845 086 9001

Email: subscriptions@bsigroup.com

Knowledge Centre

Tel: +44 20 8996 7004

Email: knowledgecentre@bsigroup.com

Copyright & Licensing

Tel: +44 20 8996 7070

Email: copyright@bsigroup.com



...making excellence a habit.™