



BSI Standards Publication

Fine ceramics (advanced ceramics, advanced technical ceramics) — Mechanical properties of monolithic ceramics at room temperature — Determination of compressive strength

National foreword

This British Standard is the UK implementation of ISO 17162:2014.

The UK participation in its preparation was entrusted to Technical Committee RPI/13, Advanced technical ceramics.

A list of organizations represented on this committee can be obtained on request to its secretary.

This publication does not purport to include all the necessary provisions of a contract. Users are responsible for its correct application.

© The British Standards Institution 2014. Published by BSI Standards Limited 2014

ISBN 978 0 580 81683 3

ICS 81.060.30

Compliance with a British Standard cannot confer immunity from legal obligations.

This British Standard was published under the authority of the Standards Policy and Strategy Committee on 31 March 2014.

Amendments issued since publication

| Date | Text affected |
|------|---------------|
|------|---------------|

INTERNATIONAL
STANDARD

ISO
17162

First edition
2014-03-15

**Fine ceramics (advanced ceramics,
advanced technical ceramics) —
Mechanical properties of monolithic
ceramics at room temperature
— Determination of compressive
strength**

*Céramiques techniques — Propriétés mécaniques des céramiques
monolithiques à température ambiante — Détermination de la
résistance en compression*



Reference number
ISO 17162:2014(E)

© ISO 2014



COPYRIGHT PROTECTED DOCUMENT

© ISO 2014

All rights reserved. Unless otherwise specified, no part of this publication may be reproduced or utilized otherwise in any form or by any means, electronic or mechanical, including photocopying, or posting on the internet or an intranet, without prior written permission. Permission can be requested from either ISO at the address below or ISO's member body in the country of the requester.

ISO copyright office
Case postale 56 • CH-1211 Geneva 20
Tel. + 41 22 749 01 11
Fax + 41 22 749 09 47
E-mail copyright@iso.org
Web www.iso.org

Published in Switzerland

Contents

| | Page |
|--------------------------------------|----------|
| Foreword | iv |
| 1 Scope | 1 |
| 2 Normative references | 1 |
| 3 Terms and definitions | 1 |
| 4 Significance and use | 1 |
| 5 Apparatus | 2 |
| 5.1 Test machine | 2 |
| 5.2 Test jig | 2 |
| 5.3 Length measuring equipment | 5 |
| 6 Test pieces | 5 |
| 6.1 Dimensions and tolerances | 5 |
| 6.2 Surface finish | 5 |
| 6.3 Number of test pieces | 7 |
| 7 Procedure | 7 |
| 8 Calculations | 8 |
| 9 Test report | 8 |

Foreword

ISO (the International Organization for Standardization) is a worldwide federation of national standards bodies (ISO member bodies). The work of preparing International Standards is normally carried out through ISO technical committees. Each member body interested in a subject for which a technical committee has been established has the right to be represented on that committee. International organizations, governmental and non-governmental, in liaison with ISO, also take part in the work. ISO collaborates closely with the International Electrotechnical Commission (IEC) on all matters of electrotechnical standardization.

The procedures used to develop this document and those intended for its further maintenance are described in the ISO/IEC Directives, Part 1. In particular the different approval criteria needed for the different types of ISO documents should be noted. This document was drafted in accordance with the editorial rules of the ISO/IEC Directives, Part 2 (see www.iso.org/directives).

Attention is drawn to the possibility that some of the elements of this document may be the subject of patent rights. ISO shall not be held responsible for identifying any or all such patent rights. Details of any patent rights identified during the development of the document will be in the Introduction and/or on the ISO list of patent declarations received (see www.iso.org/patents).

Any trade name used in this document is information given for the convenience of users and does not constitute an endorsement.

For an explanation on the meaning of ISO specific terms and expressions related to conformity assessment, as well as information about ISO's adherence to the WTO principles in the Technical Barriers to Trade (TBT) see the following URL: Foreword - Supplementary information

The committee responsible for this document is ISO/TC 206, *Fine ceramics*.

Fine ceramics (advanced ceramics, advanced technical ceramics) — Mechanical properties of monolithic ceramics at room temperature — Determination of compressive strength

1 Scope

This International Standard specifies a method for the determination of nominal compressive strength of advanced monolithic technical ceramic materials at room temperature.

2 Normative references

The following documents, in whole or in part, are normatively referenced in this document and are indispensable for its application. For dated references, only the edition cited applies. For undated references, the latest edition of the referenced document (including any amendments) applies.

ISO 3611, *Geometrical product specifications (GPS) — Dimensional measuring equipment: Micrometers for external measurements — Design and metrological characteristics*

ISO 7500-1, *Metallic materials — Verification of static uniaxial testing machines — Part 1: Tension/compression testing machines — Verification and calibration of the force-measuring system*

ISO/IEC 17025, *General requirements for the competence of testing and calibration laboratories*

EN 623-4, *Advanced technical ceramics — Monolithic ceramics — General and textural properties — Part 4: Surface roughness*

EN 843-5, *Advanced technical ceramics — Mechanical properties of monolithic ceramics at room temperature — Part 5: Statistical analysis*

3 Terms and definitions

For the purposes of this document, the following terms and definitions apply.

3.1

nominal compressive strength

$\sigma_{c,m}$

maximum nominal stress supported by the material at the instant of failure when loaded in linear elastic compression

4 Significance and use

Advanced technical ceramics are used for applications in which their corrosion resistance, their high temperature stability, their potential for light-weight constructions, and their high nominal compressive strength can be utilized in an ideal manner. For application of ceramic components, it shall be considered that they are loaded mainly with compressive stresses since this type of loading is considerably less critical than probably appearing tensile stresses.

This International Standard describes the background for a directed material development, quality control, and for component-optimised applications. It ensures the determination of comparable nominal compressive strength data.

The result obtained from a compression strength test is determined by a large number of factors associated with the microstructure of the material, the surface finishing procedure applied for the preparation of the test pieces, the size and shape of the test piece, the rate of load application, and the relative humidity of the ambient atmosphere. Furthermore, the result obtained from a strength test is influenced by possible existing misfit of ram and test piece cross section as well as of elastic constants. These factors are minimized by a sophisticated test assembly in ASTM C 1424-04 [1]. With respect to an applicable and reproducible procedure of the measurement, it is consciously abstained from the adoption of this test assembly. The test assembly defined in this International Standard represents an alternative to the above mentioned ASTM C 1424-04 [1] that is approved and feasible in industrial practice.

As a consequence of the brittle nature of ceramics, there is usually a considerably range of results obtained from a number of nominal identical test pieces. The factors (mentioned above) combined mean that caution in the interpretation of test results is required. For many purposes, and as described in this International Standard, the results of strength test can be described in terms of a mean value and a standard deviation. Further statistical evaluation of results is required for design data acquisition, and can be desirable for other purposes (see EN 843-5).

This method places closely defined restrictions on the size and shape of the test pieces and on the function of the test apparatus in order to minimize the errors that can arise as a consequence of the test method.

5 Apparatus

5.1 Test machine

A test machine shall be used that conforms to the safety requirements defined in ISO 7500-1 and ISO 7500-1 Amendment 1. The test jig shall be surrounded by an adequate shatter protection device.

The test machine shall be capable of applying the force at a constant loading or displacement rate. The machine shall be equipped to continuously record the force applied to the test piece including the maximum force applied to the test piece. The accuracy of the test machine shall be in accordance with ISO 7500-1, grade 1.

5.2 Test jig

The test jig shall be capable to perform compression tests and ensure to meet the requirements described below.

In [Figure 1](#) an example of a test jig is shown and in [Figure 2](#) a schematic representation of the test jig including a compression platen with calotte for self-alignment.

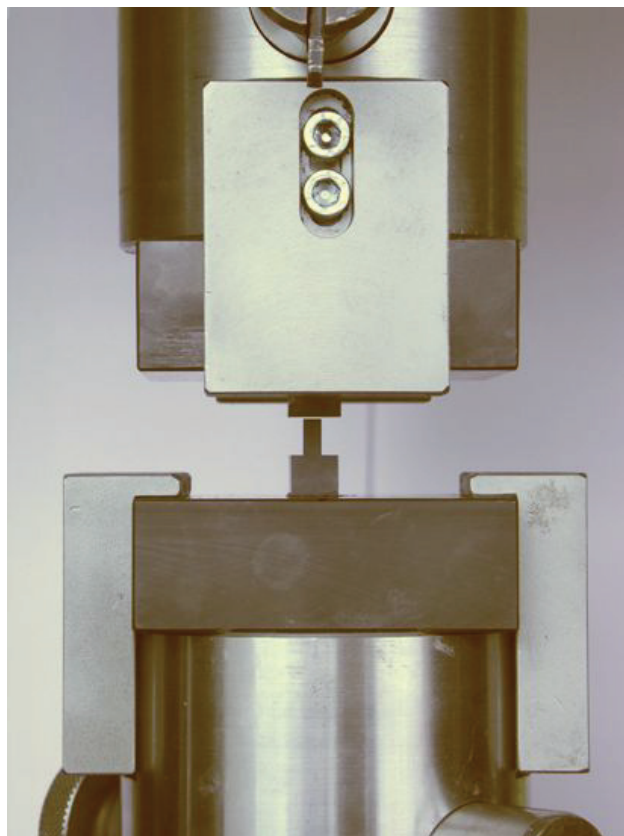
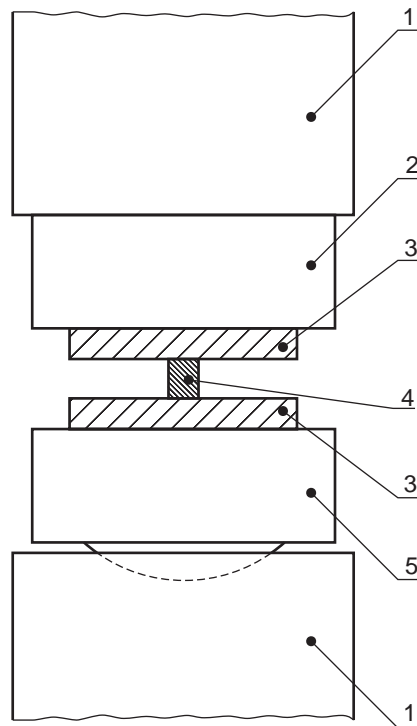

Figure 1 — Example of a test jig



Key

- 1 load ram
- 2 compression platen
- 3 loading block
- 4 compressive test piece
- 5 compression platen with calotte

Figure 2 — Schematic representation of the test jig including a compression platen with calotte for self-alignment

The two compression platens shall be aligned axially to the load line of the test machine. The loading surfaces of the upper and lower compression platens shall be parallel to each other within 0,01 mm per 10 mm and perpendicular to the load line of the test machine.

For a better alignment, one of the compression platens should have a calotte for self-alignment.

Hardness and Young's modulus of the loading blocks and compression platens shall be larger than or equal to the hardness and Young's modulus (≥ 400 GPa, e.g. silicon carbide or cemented carbide) of the test piece.

Loading blocks positioned between compression platens and the test piece as shown in [Figures 1](#) and [2](#) shall be used to minimize mismatches between compression platens and test piece and to protect the compression platens against damage. Loading blocks could be made from the same material as the test pieces.

The surface of the compression platen that is in contact with the loading block shall be larger than the surface of the loading block that is in contact with the compression platen. The cross section of the contact surface of the loading blocks shall be at least five times greater than the cross sections of the contact surfaces (end faces) of the test piece. The loading blocks shall have a thickness large enough to resist the test without fracture and shall be used only once.

The compression platens shall be checked for damage after each compression test. Damaged compression platens shall be replaced or refinished to remove the volume damaged.

The lower loading block shall be placed centred on the lower compression platen and the test piece shall be placed centred on the lower loading block. Subsequently, the upper loading block shall be placed centred on the upper end face of the test piece and the upper compression platen shall be moved towards the upper loading block until force closure. Optical markers or other suitable devices shall be used for central alignment of test piece and loading blocks.

5.3 Length measuring equipment

A micrometer conforming to ISO 3611 and with a resolution $\leq 0,1$ % of the dimension to be measured, or an alternative calibrated device measuring to this resolution, shall be used for the measurement of test piece dimensions.

6 Test pieces

6.1 Dimensions and tolerances

A test piece with a square cross section with side lengths of $(4 \pm 0,1)$ mm or with a cylindrical cross section with a diameter of $(4,5 \pm 0,1)$ mm shall be used. The test piece shall have a height of $(8 \pm 0,2)$ mm with end faces parallel to $0,2$ % relative to the side length or the diameter of the test piece. The long edges of the squared test piece shall be chamfered at approximately 45° to a width of $(0,25 \pm 0,05)$ mm.

Other shapes or dimensions of test pieces can be used according to agreement between the parties and shall be stated in the test report.

6.2 Surface finish

6.2.1 General

This International Standard permits any relevant surface finish described in the following four categories:

- I: as-fired;
- II: machined,;
- III: lapping/polishing;
- IV: agreed procedure.

Categories II or III are recommended when there is no other specified method for the test. The aim of procedures according to categories II and III is to minimize the damage created in the test pieces due to the preparation method in order to examine strength more representative of the material than the machining. The recommended procedures cannot be standardized in the conventional sense because of variation between grinding machines and the different behaviours during grinding of different types of material. The procedures described should thus be considered as guidelines. Furthermore, since there are no methods for exact measurement of the surface finish parameters of ceramic materials, special attention should be paid to the quality of the machining.

6.2.2 Surface finish I: as-fired

The test pieces to be tested in the as-fired (ex-kiln) condition with surface preparation only on the sample end-face (in order to avoid edge stresses) provided shall have dimensions according to [6.1](#). The long edge chamfer of square test pieces shall be applied before firing. Test pieces which are outside these limits shall be rejected.

6.2.3 Surface finish II: finishing by grinding

The test pieces shall be subjected to the following grinding procedure.

- a) Rough grinding with a continuous rim peripheral diamond grinding wheel which is round to within 0,03 mm and of grit size not exceeding 120 mesh (D126), using a depth of cut not exceeding 0,03 mm per pass. Discontinuous rim grinding wheels shall not be used.
- b) Finish grinding with a peripheral grinding wheel of grit size between 320 mesh and 500 mesh (e.g. D46 or finer), using a depth of cut not exceeding 0,002 mm per pass and removing at least 0,06 mm of material. The final pass shall have zero cut.

All grinding shall be performed parallel to the length axis of the test piece, and an adequate quantity of coolant shall be used at all times. Approximately equal amounts of material shall be removed from opposite end faces of test pieces.

Alternatively, an appropriate creep-feed grinding process can be applied by using the same diamond grit size wheels as specified in a) and with the finish grinding procedure according to b) including removal of at least 0,06 mm of material with final passes with depths of cut of 0,002 mm and 0 mm.

If required, measure the surface roughness, R_t , using a profilometer with a stylus tip radius less than 5 μm in accordance with EN 623-4 ignoring obvious pores. The surface roughness R_t shall be less than 2 μm .

6.2.4 Surface finish III: finishing by lapping and/or polishing

The test faces and the adjacent chamfered edges of the test pieces shall be lapped and/or polished using abrasives less than 30 μm grit size, progressively reducing in size. A thickness of at least 50 μm shall be removed from the test faces during this operation in order to remove pre-existing damage from rough grinding or cutting operations. At least 5 μm shall be removed using abrasives of less than 6 μm grit size.

NOTE The recommended depths of material removal are not always essential and depend on the nature of the material, especially its fracture toughness.

Any deviation from the above procedure shall be by agreement between parties and be stated in the test report.

The polished test pieces shall be free from visual scratches, This shall be checked, for example, with a low-power microscope with a magnification of $100\times$. Furthermore, if needed, measure the surface roughness, R_t , using a profilometer with a tip radius of less than 5 μm , in accordance with EN 623-4 ignoring obvious pores. The surface roughness, R_t , shall be less than 1 μm .

6.2.5 Surface finish IV: finishing by agreed procedure

If test pieces shall be prepared from blocks of material and tested as-cut, they shall be carefully cut using a diamond saw [grit size not greater than D151¹⁾: approximately 125 μm to 150 μm in order to obtain a surface roughness R_t not greater than 5 μm (ignoring obvious pores, see EN 623-4)]. The test pieces can be prepared with a saw, ground and/or lapped surface finish using an agreed sequence of abrasives, machining direction and material removal rates. They can also be annealed or refired after machining. Full details of preparation procedures shall be recorded in the test report.

NOTE The effects of previous coarser grinding stages are not necessarily eliminated by the use of a fine abrasive for a finishing process. Caution is advised when interpreting strength dates related to finishing processes.

6.2.6 Chamfers

The long edges of the square test piece shall be chamfered at approximately 45° to a distance of (0,25 ± 0,05) mm as measured along the side of the test piece.

1) Federation of European Abrasives Producers (FEPA) designation.

The machining direction during chamfering shall be performed parallel to the length axis of the test piece.

6.3 Number of test pieces

For material development, characterization or quality control, the minimum number of test pieces shall be ten. For statistical evaluation of strength data (e.g. Weibull parameters) in accordance with EN 843-5, the minimum number shall be 30.

NOTE Weibull parameters can be seriously in error if the number of nominally identical test pieces is less than 30. Because of the uncertainty of the parameters, then a comparison between batches of a material or between different materials becomes meaningless.

7 Procedure

At the beginning of the test series record the ambient temperature of the test environment to the nearest 1 °C and the relative humidity (RH) to the nearest 5 %. The relative humidity shall not change by more than 10 % during the course of the test series.

NOTE By avoiding massive solar radiation and high air exchange it can be assumed that the recommendations given above can be kept.

Measure the height of each test piece to the nearest 0,01 mm and the width and thickness or the diameter to the nearest 0,002 mm. Test piece dimensions shall be measured before the test and stated in the test report.

Load the test piece between the parallel loading blocks with constant loading rate until fracture occurs. Select a rate of load application such that fracture is obtained in a time period of 10 s to 30 s.

Failure by fracture shall be defined as the moment of the first significant decrease of the force. Record the achieved maximum force supported by the test piece at the instant of failure and the loading time until failure occurs in the test report.

8 Calculations

Calculate the nominal compressive strength, $\sigma_{c,m}$, of each test piece, expressed as newton per square millimetre, using Formula (1):

$$\sigma_{c,m} = \frac{F}{A_0} \quad (1)$$

For cylindrical test pieces, calculate A_0 using Formula (2):

$$A_0 = \frac{\pi}{4} d^2 \quad (2)$$

For chamfered square test pieces, calculate A_0 using Formula (3):

$$A_0 = a^2 - 2f^2 \quad (3)$$

where in Formulae (1) to (3)

- F is the maximum force at fracture, in newtons (N);
- A_0 is the cross sectional area of the test piece, in square millimetres (mm²);
- d is the diameter of the cylindrical test piece, in millimetres (mm);
- a is the width (thickness) of the square test piece, in millimetres (mm);
- f is the width of the chamfer, in millimetres (mm).

The nominal compressive strength of each test piece shall be stated in the test report to three significant figures.

9 Test report

The test report shall be in accordance with ISO/IEC 17025 and shall contain the following information:

- a) name and address of the testing establishment;
- b) date of the test, unique identification of the test report and of each page, the customer name and address, and signatory;
- c) reference to this International Standard (i.e. ISO 17162);
- d) assembly of the test jig, i.e. specification of the materials of the compression platens and the loading blocks;
- e) date of the delivery of the test pieces;
- f) description of the test material type, the manufacturing code, and the batch number;
- g) method of production of test pieces and the surface finish category appropriate to the preparation method, i.e. I, II, III, or IV;
- h) dimensions of each test piece and, if known, the direction in that test pieces were machined out of components or blocks;
- i) number of test pieces tested;
- j) average ambient test temperature and average relative humidity during the tests;

- k) individual nominal compressive strength values for each test piece;
- l) unless otherwise agreed, the mean nominal compressive strength and the standard deviation;
- m) remarks about the test or the test results, details of any necessary deviations from this International Standard.

British Standards Institution (BSI)

BSI is the national body responsible for preparing British Standards and other standards-related publications, information and services.

BSI is incorporated by Royal Charter. British Standards and other standardization products are published by BSI Standards Limited.

About us

We bring together business, industry, government, consumers, innovators and others to shape their combined experience and expertise into standards-based solutions.

The knowledge embodied in our standards has been carefully assembled in a dependable format and refined through our open consultation process. Organizations of all sizes and across all sectors choose standards to help them achieve their goals.

Information on standards

We can provide you with the knowledge that your organization needs to succeed. Find out more about British Standards by visiting our website at bsigroup.com/standards or contacting our Customer Services team or Knowledge Centre.

Buying standards

You can buy and download PDF versions of BSI publications, including British and adopted European and international standards, through our website at bsigroup.com/shop, where hard copies can also be purchased.

If you need international and foreign standards from other Standards Development Organizations, hard copies can be ordered from our Customer Services team.

Subscriptions

Our range of subscription services are designed to make using standards easier for you. For further information on our subscription products go to bsigroup.com/subscriptions.

With **British Standards Online (BSOL)** you'll have instant access to over 55,000 British and adopted European and international standards from your desktop. It's available 24/7 and is refreshed daily so you'll always be up to date.

You can keep in touch with standards developments and receive substantial discounts on the purchase price of standards, both in single copy and subscription format, by becoming a **BSI Subscribing Member**.

PLUS is an updating service exclusive to BSI Subscribing Members. You will automatically receive the latest hard copy of your standards when they're revised or replaced.

To find out more about becoming a BSI Subscribing Member and the benefits of membership, please visit bsigroup.com/shop.

With a **Multi-User Network Licence (MUNL)** you are able to host standards publications on your intranet. Licences can cover as few or as many users as you wish. With updates supplied as soon as they're available, you can be sure your documentation is current. For further information, email bsmusales@bsigroup.com.

BSI Group Headquarters

389 Chiswick High Road London W4 4AL UK

Revisions

Our British Standards and other publications are updated by amendment or revision.

We continually improve the quality of our products and services to benefit your business. If you find an inaccuracy or ambiguity within a British Standard or other BSI publication please inform the Knowledge Centre.

Copyright

All the data, software and documentation set out in all British Standards and other BSI publications are the property of and copyrighted by BSI, or some person or entity that owns copyright in the information used (such as the international standardization bodies) and has formally licensed such information to BSI for commercial publication and use. Except as permitted under the Copyright, Designs and Patents Act 1988 no extract may be reproduced, stored in a retrieval system or transmitted in any form or by any means – electronic, photocopying, recording or otherwise – without prior written permission from BSI. Details and advice can be obtained from the Copyright & Licensing Department.

Useful Contacts:

Customer Services

Tel: +44 845 086 9001

Email (orders): orders@bsigroup.com

Email (enquiries): cservices@bsigroup.com

Subscriptions

Tel: +44 845 086 9001

Email: subscriptions@bsigroup.com

Knowledge Centre

Tel: +44 20 8996 7004

Email: knowledgecentre@bsigroup.com

Copyright & Licensing

Tel: +44 20 8996 7070

Email: copyright@bsigroup.com



...making excellence a habit.™