

BS ISO 17101-2:2012



BSI Standards Publication

Agricultural machinery — Thrown-object test and acceptance criteria

Part 2: Flail mowers

bsi.

...making excellence a habit.™

National foreword

This British Standard is the UK implementation of ISO 17101-2:2012. Together with BS ISO 17101-1:2012, it supersedes BS ISO 17101:2004, which is withdrawn.

The UK participation in its preparation was entrusted to Technical Committee AGE/32, Agricultural implements and trailers.

A list of organizations represented on this committee can be obtained on request to its secretary.

This publication does not purport to include all the necessary provisions of a contract. Users are responsible for its correct application.

© The British Standards Institution 2012.

Published by BSI Standards Limited 2012

ISBN 978 0 580 72695 8

ICS 65.060.01; 65.060.50; 65.060.70

Compliance with a British Standard cannot confer immunity from legal obligations.

This British Standard was published under the authority of the Standards Policy and Strategy Committee on 31 July 2012.

Amendments/corrigenda issued since publication

Date	Text affected
-------------	----------------------

**Agricultural machinery — Thrown-object
test and acceptance criteria —**

**Part 2:
Flail mowers**

*Matériel agricole — Essai de projection d'objets et critères
d'acceptation —*

Partie 2: Faucheuses-broyeuses





COPYRIGHT PROTECTED DOCUMENT

© ISO 2012

All rights reserved. Unless otherwise specified, no part of this publication may be reproduced or utilized in any form or by any means, electronic or mechanical, including photocopying and microfilm, without permission in writing from either ISO at the address below or ISO's member body in the country of the requester.

ISO copyright office
Case postale 56 • CH-1211 Geneva 20
Tel. + 41 22 749 01 11
Fax + 41 22 749 09 47
E-mail copyright@iso.org
Web www.iso.org

Published in Switzerland

Contents

Page

Foreword	iv
1 Scope	1
2 Normative references	1
3 Terms and definitions	2
4 Thrown object test	2
4.1 Testing conditions	2
4.2 Target	3
4.3 Test material	18
4.4 Test run conditions	19
4.5 Test procedure	20
4.6 Test results and report	22
4.7 Acceptance criteria	22
Annex A (informative) Illustrations of mowers	23
Annex B (informative) ISO 17101-2 Thrown-object test reports — Flail mowers	26
Bibliography	31

Foreword

ISO (the International Organization for Standardization) is a worldwide federation of national standards bodies (ISO member bodies). The work of preparing International Standards is normally carried out through ISO technical committees. Each member body interested in a subject for which a technical committee has been established has the right to be represented on that committee. International organizations, governmental and non-governmental, in liaison with ISO, also take part in the work. ISO collaborates closely with the International Electrotechnical Commission (IEC) on all matters of electrotechnical standardization.

International Standards are drafted in accordance with the rules given in the ISO/IEC Directives, Part 2.

The main task of technical committees is to prepare International Standards. Draft International Standards adopted by the technical committees are circulated to the member bodies for voting. Publication as an International Standard requires approval by at least 75 % of the member bodies casting a vote.

Attention is drawn to the possibility that some of the elements of this document may be the subject of patent rights. ISO shall not be held responsible for identifying any or all such patent rights.

ISO 17101-2 was prepared by Technical Committee ISO/TC 23, *Tractors and machinery for agriculture and forestry*, Subcommittee SC 7, *Equipment for harvesting and conservation*.

This first edition of ISO 17101-2, together with ISO 17101-1, cancels and replaces ISO 17101:2004, which has been technically revised.

ISO 17101 consists of the following parts, under the general title *Agricultural machinery — Thrown-object test and acceptance criteria*:

- *Part 1: Rotary mowers*
- *Part 2: Flail mowers*

Agricultural machinery — Thrown-object test and acceptance criteria —

Part 2: Flail mowers

1 Scope

This part of ISO 17101 gives specifications and acceptance criteria for the thrown-object testing of flail mowers used in agriculture. Examples of machines are shown in Annex A.

It is not applicable to the following:

- large rotary mowers;
- rotary mowers;
- mowers with an articulated arm;
- mowers with one or more vertical axis designed for mulching;
- pedestrian controlled motor mowers;
- lawn mowers or machines designed as lawn mowers;
- inter-row mowing units;
- machines designed for highway and road maintenance only;
- flail mowers that have the rear part which can be opened for particular field use operations (e.g. row-crop mowers).

NOTE 1 If a machine is also designed for use outside agriculture, in addition to the thrown-object test given in this part of ISO 17101, other thrown object tests might apply.

NOTE 2 Thrown-object tests and acceptance criteria for rotary mowers are dealt with in ISO 17101-1.

2 Normative references

The following documents, in whole or in part, are normatively referenced in this document and are indispensable for its application. For dated references, only the edition cited applies. For undated references, the latest edition of the referenced document (including any amendments) applies.

ISO 536:—¹⁾, *Paper and board — Determination of grammage*

ISO 789-1:1990, *Agricultural tractors — Test procedures — Part 1: Power tests for power take-off*

ISO 1974:2012, *Paper — Determination of tearing resistance — Elmendorf method*

ISO 2758:—²⁾, *Paper — Determination of bursting strength*

ISO 3416:1986, *Textile floor coverings — Determination of thickness loss after prolonged, heavy static loading*

1) To be published. (Revision of ISO 536:1995)

2) To be published. (Revision of ISO 2758:2001)

3 Terms and definitions

For the purposes of this document, the following terms and definitions apply.

3.1 rotary mower
mower in which one or more functional components cut or shear forage crop by impact without mulching and rotate about a vertical axis

[SOURCE: ISO 4254-12:2012, definition 3.1]

3.2 flail mower
mower with a multiplicity of free-swinging cutting elements that rotates about a horizontal axis, cuts the crop by impact and mulches it with the same working elements

[SOURCE: ISO 4254-12:2012, definition 3.2]

3.3 conditioning device
mechanical device allowing the acceleration of the crop-drying process

NOTE Examples of acceleration of the crop-drying process include crushing, impact, abrasion and lamination.

3.4 swath board
adjustable device for controlling the swath width

3.5 Kraft paper
paper produced from pure unbleached sulfate Kraft pulp with machine finished surface

NOTE 1 Kraft paper is mainly used for the manufacture of paper sacks and for lining and laminating.

NOTE 2 See 4.2.1.1 for specific details.

3.6 test
operation consisting of two runs

3.7 run
single pass through the thrown-object material

3.8 impact
hole in the Kraft paper caused by a stone through which a cylindrical stick with a 6 mm diameter semi-spherical end passes without noticeable effort on the hand of the operator

4 Thrown object test

4.1 Testing conditions

4.1.1 Mower used for test

Tests shall be performed using the same flail mower, and the same protective devices. If the flail mower can be operated in different working positions (right side, centre or left side of the tractor, see 4.2.7), the test shall be performed with the flail mower in the rightmost and leftmost working positions behind the tractor as specified by the manufacturer in the operator's manual.

4.1.1.1 Thrown-object guard adjustment

Adjustable devices, which may influence the efficiency of the protective device to prevent projections, shall be located in the least favourable position.

4.1.1.2 Cutting height

The cutting height shall be adjusted at 50 mm. If this is not possible due to the design of the flail mower, the cutting height shall be adjusted as near as possible to 50 mm.

4.1.2 Test surface area

4.1.2.1 Ground conditions

Tests shall be performed on firm and horizontal, hard ground.

EXAMPLES Concrete, asphalt.

4.1.2.2 Coconut matting

The test surface area shall be lined with coconut matting with fibres measuring approximately 20 mm in height, embedded in a support material. The determination of compression behaviour shall be carried out in compliance with ISO 3416.

4.1.2.3 Sand layer (natural, crushed or uncrushed)

The coconut matting shall be covered with a layer of sand and shall be distributed in such a way as to leave visible the top of the coconut matting fibres. This condition shall be restored after each run.

4.1.2.4 Moisture

The test surface area shall be humidified to reach saturation point and be kept moist during the test.

4.2 Target

A target is used to record the impact of stones projected from the protected zone of the flail mower.

4.2.1 Target construction

4.2.1.1 Target material

The panels shall be constructed of a rigid frame. The dimensions of Panels 1 to 4 are shown in Figure 1; the dimensions of Panels 5 and 7 are shown in Figure 3; and the dimensions of Panel 6 are shown in Figure 2 a).

The Kraft paper shall be of $120 \text{ g/m}^2 \pm 10 \text{ g/m}^2$ construction, determined in accordance with ISO 536. The bursting strength shall be 500 kPa minimum, determined by using the method specified in ISO 2758. The tearing resistance shall be 1 200 mN minimum, in the machine direction, determined in accordance with the test method specified in ISO 1974.

4.2.1.2 Target material attachment

There shall be no reinforcing slat within 20 mm from the Kraft paper. There shall be no overlapping of Kraft paper, and, in order to have no overlaps, the Kraft paper should be stretched from the roll in the horizontal direction on the frames.

In order to have no overlaps per panel, it is recommended that the Kraft paper from the roll be stretched in a horizontal direction.

4.2.1.3 Target panels' frame

Panels 1 to 4 shall be made of a rigid frame, 2 000 mm in height, plus the thickness of the top supporting slat (see Figures 2 to 6).

4.2.1.4 Panel reference lines

Three horizontal reference lines, traced along the target at 200 mm, 600 mm and 2 000 mm from the ground level, shall show three zones:

- a lower zone (between 0 mm and 200 mm);
- a middle zone (between 200 mm and 600 mm); and
- an upper zone (between 600 mm and 2 000 mm) (see Figure 1).

If the flail-mower configuration requires the panels shown in Figures 5 to 11 to be moved further from the flail mower, the reference lines shall be moved proportionally upwards [see Figure 2 a)].

The horizontal reference lines of Panel 6, which is used for front-mounted flail mowers [see Figure 2 b)], shall be located 500 mm and 1 000 mm from the ground level and show three zones:

- a lower zone (between 200 mm and 500 mm);
- a middle zone (between 500 mm and 1 000 mm); and
- an upper zone (between 1 000 mm and 1 200 mm).

If Panel 6 needs to be moved towards the rear due to the flail-mower dimensions, reference lines shall be moved proportionally upwards. [see Figure 2 c)].

Panels 1 to 4 shall be divided into vertical sections 1 000 mm wide, starting from one of the edges of the enclosure formed by the target panels. Panel 6, if present, shall also be divided into vertical sections 1 000 mm wide, starting from one of its edges. The sections shall be numbered.

Dimensions in millimetres

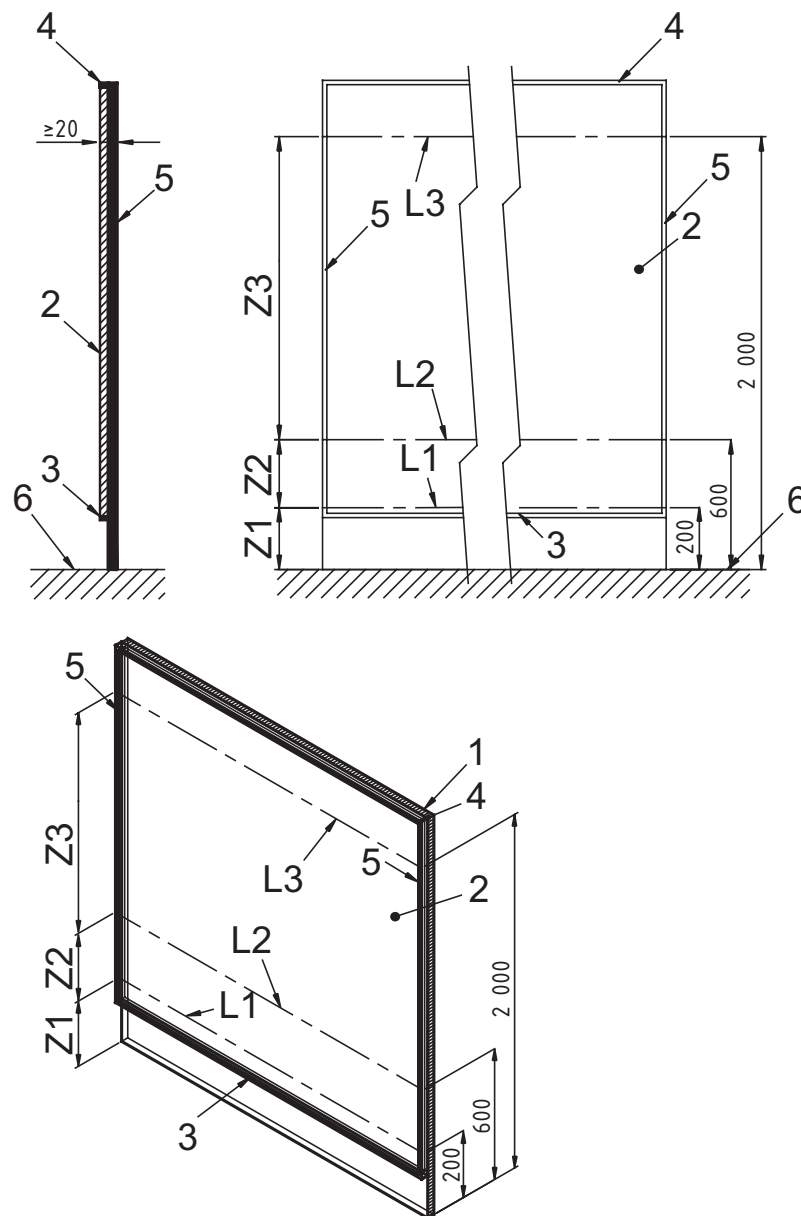

Key

L1	200 mm reference line	1	panel
L2	600 mm reference line	2	Kraft paper
L3	2 000 mm reference line	3	lower reinforcing slat
Z1	lower zone	4	upper reinforcing slat
Z2	middle zone	5	side reinforcing slat
Z3	upper zone	6	ground

Figure 1 — Target panel

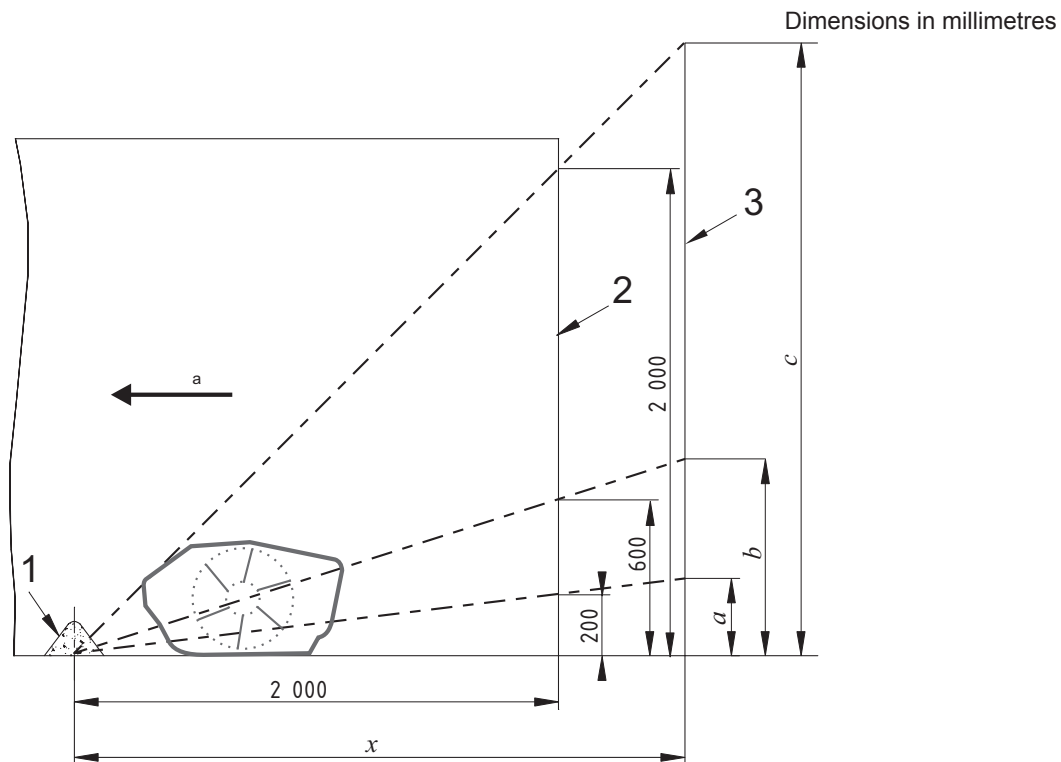

Key

- 1 test material
- 2 panel (as specified)
- 3 panel for adjusted reference lines
- $a = (200x)/(2\ 000)$
- $b = (600x)/(2\ 000)$
- $c = x$
- x equal to panel height c
- a Forward direction.

a) Example of proportional reference line adjustment for Panel 6

Figure 2 (continued on the next page)

Dimensions in millimetres

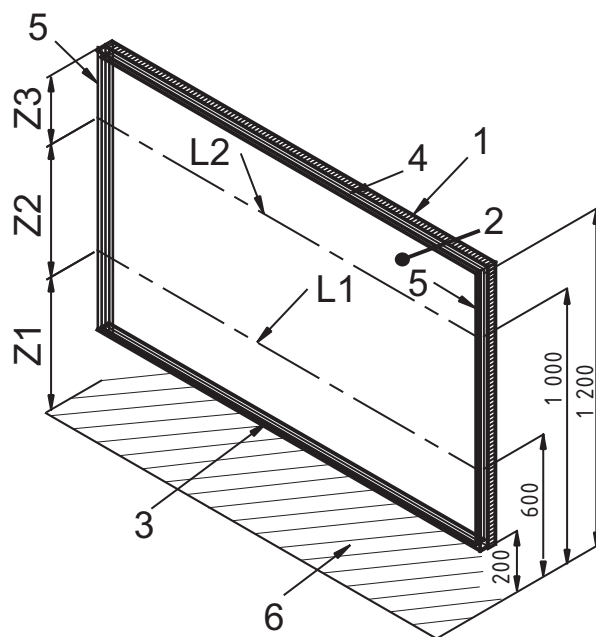
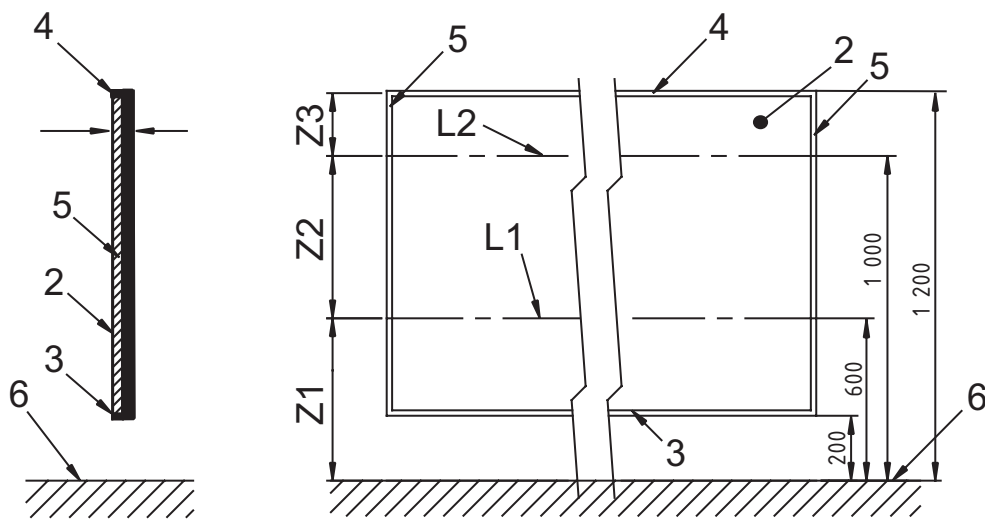

Key

- L1 500 mm reference line
- L2 1 000 mm reference line
- Z1 lower zone
- Z2 middle zone
- Z3 upper zone

- 1 panel
- 2 Kraft paper
- 3 lower reinforcing slat
- 4 upper reinforcing slat
- 5 side reinforcing slat
- 6 ground

b) Reference lines for Panel 6 front-mounted flail mowers

Figure 2 (continued on the next page)

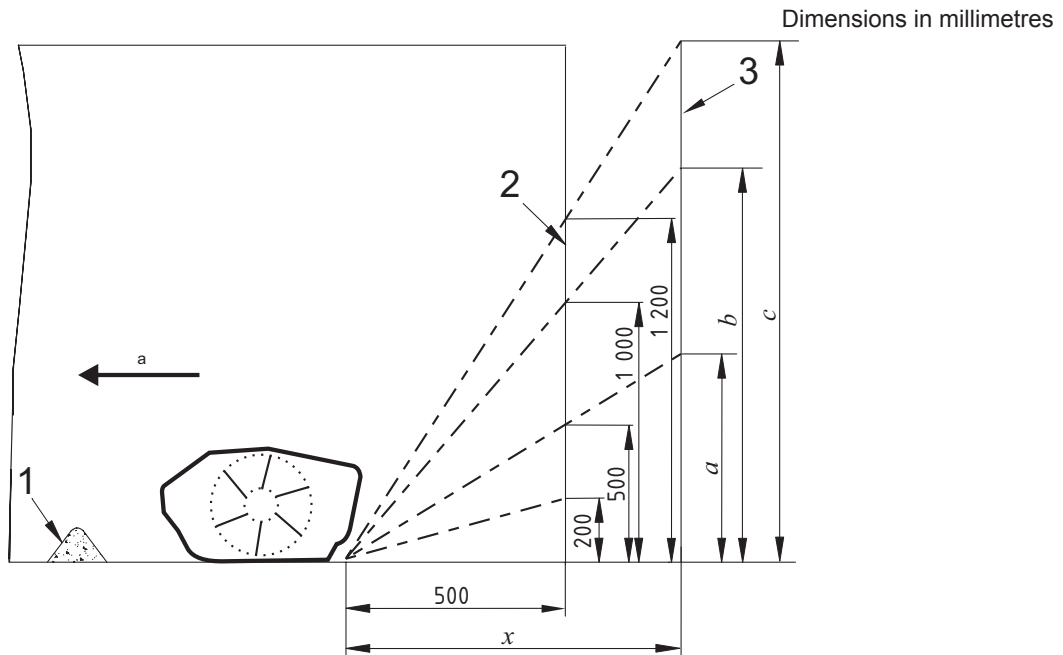

Key

- 1 test material
- 2 panel (as specified)
- 3 panel 6 for adjusted reference lines

$a = x$

$b = (1\,000 \cdot x) / (500)$

$c = (1\,200 \cdot x) / (500)$

x equal to panel height c

a Forward direction.

c) Proportional adjustment for Panel 6

Figure 2 — Panel 6

4.2.2 Panels in the operator’s zone for flail mowers attached at the rear three-point tractor linkage

Panels 5, 7a, and 7b act as a target in the operator’s zone (see Figure 3). They shall be made of a rigid frame and shall comply with the specifications given in Table 1 and Table 2.

At the rear angle of Panels 7a and 7b, there can be a slat in contact with paper and with a maximum thickness of 3 mm.

Panel 5, which shall be in a vertical plane, connects Panels 7a and 7b and shall be perpendicular to them. Panels 7a and 7b shall be parallel to the longitudinal axis of the tractor.

For three-point tractor linkage mowers, Panel 5 shall be located in a horizontal distance of (800 ± 50) mm in front of the axis of the lower hitch points of the mower.

NOTE 1 In order to comply with the required dimensions, it might be necessary to use an intermediate frame on which Panel 5 can be mounted and which is mounted between the hitch points of the tractor and the hitch points of the mower.

Figure 5 shows an example of the location of Panel 5.

For trailed and semi-mounted flail mowers, the following requirements apply.

- a) For lower linkage coupled flail mowers, Panel 5 shall be located in a horizontal distance of (800 ± 50) mm in front of the axis of the hitch points of the flail mower.

NOTE 2 In order to comply with the required dimensions, it might be necessary to use an intermediate frame on which Panel 5 can be mounted and which is mounted between the hitch points of the tractor and the hitch points of the flail mower.

- b) For all other trailed flail mowers, e.g. drawbar, hitch hook, piton fix, ball type, Panel 5 shall be located in a horizontal distance of (600 ± 50) mm in front of the coupling point of the flail mower.

NOTE 3 In order to comply with the required dimensions, it might be necessary to use an intermediate frame on which Panel 5 can be mounted and which is mounted between the coupling point of the tractor and the coupling point of the flail mower.

Dimensions in millimetres

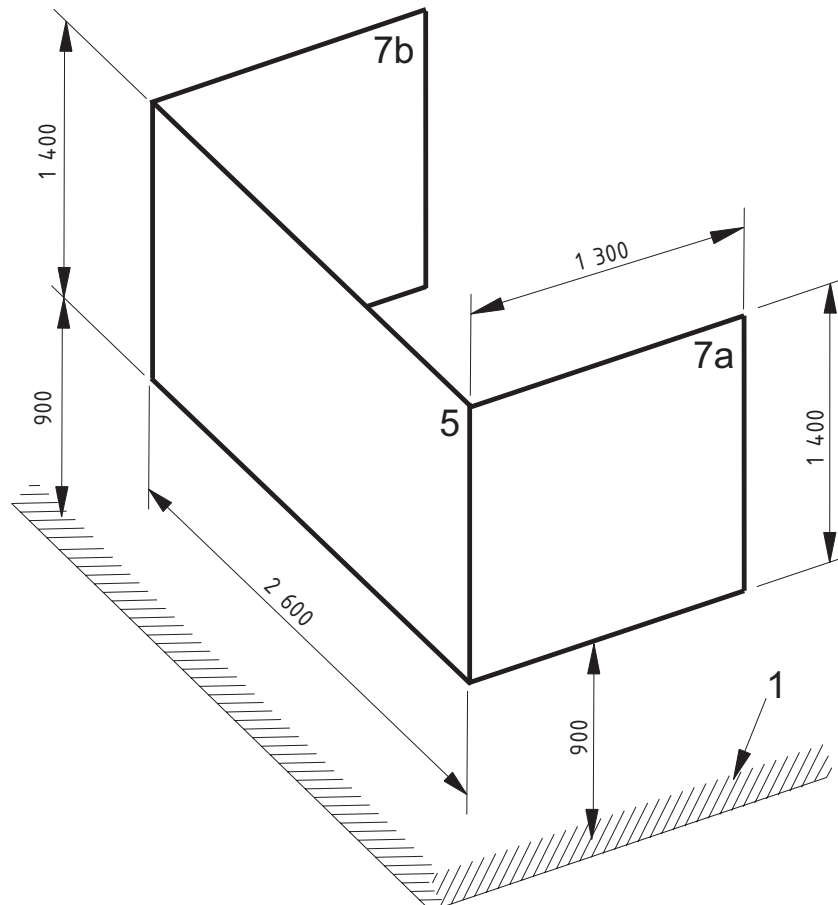

Key

- 1 ground
- 5 Panel 5
- 7a Panel 7a
- 7b Panel 7b

a) Configuration for standard tractors

Table 1 — Dimensions for Panels 5, 7a and 7b in Figure 3 a)

Dimensions in millimetres

	Height	Width	Height above the ground of the lower edge
Panel 5	1 400	2 600	900 ± 10
Panel 7a	1 400	1 300	900 ± 10
Panel 7b	1 400	1 300	900 ± 10

Figure 3 (continued on the next page)

Dimensions in millimetres

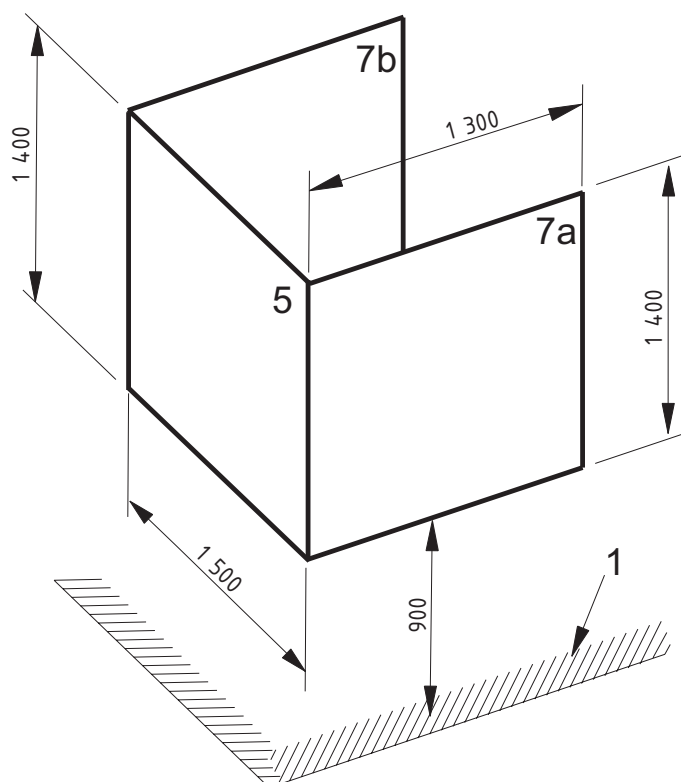

Key

- 1 ground
- 5 Panel 5
- 7a Panel 7a
- 7b Panel 7b

b) Configuration for narrow tractors

Table 2 — Dimensions for narrow tractors for Panels 5, 7a and 7b in Figure 3 b)

Dimensions in millimetres

	Height	Width	Height above the ground of the lower edge
Panel 5	1 400	1 500	900 ± 10
Panel 7a	1 400	1 300	900 ± 10
Panel 7b	1 400	1 300	900 ± 10

Figure 3 — Configuration of panels 5, 7a and 7b in the operator's zone

4.2.3 Target for offset flail mowers attached at the rear three-point tractor linkage (see Figure 4)

Dimensions in millimetres

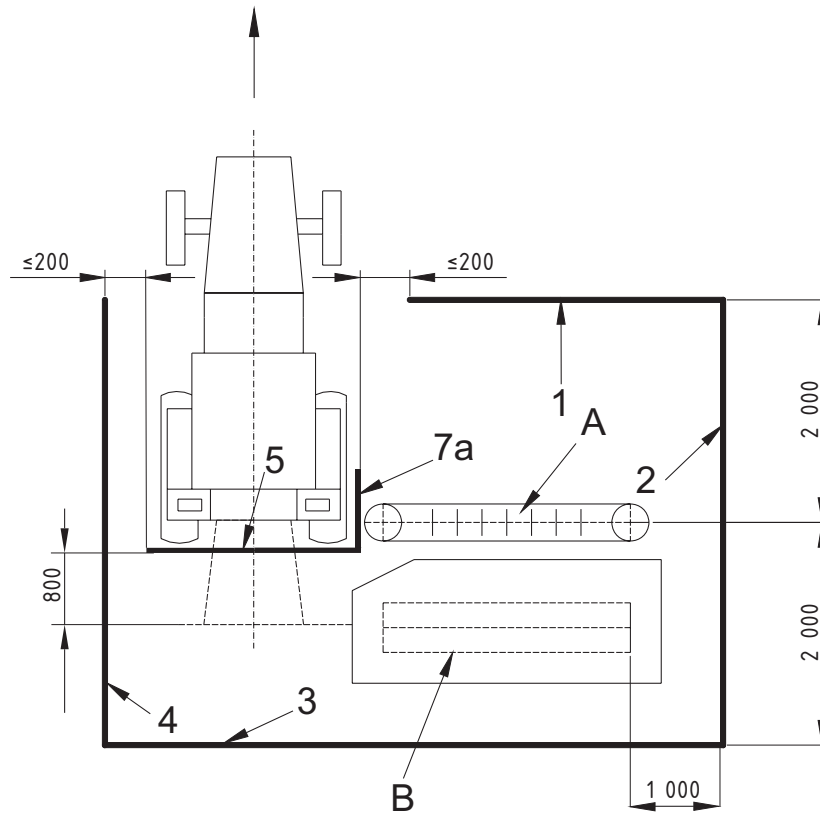

Key

- A test material
- B tool path
- panels (1, 2, 3, 4, 5, 7a)

Figure 4 — Target panel configuration for offset flail mowers

The target shall be constructed of six panels (Panels 1, 2, 3, 4, 5 and 7a) and shall comply with the specifications of 4.2.1 and 4.2.2.

Panels 2 and 4 shall be 4 000 mm long. If, due to flail mower dimensions, it is not possible to achieve this length, it may be increased. In this case, Panel 3 shall be located at a maximum horizontal distance of 200 mm from the rear of the flail mower in the test starting position.

Panel 2 shall be parallel to the longitudinal tractor axis and located at a distance of 1 000 mm from the nearest tool path.

Panel 4 shall be parallel to Panel 2 and located at a distance of 2 000 mm from the nearest tool path. If, due to flail mower dimensions, it is not possible to achieve this length, it may be increased. In this case, Panel 4 shall be located at a maximum horizontal distance of 200 mm from the rear wheel of the tractor or the edge of Panel 5, whichever is wider. The reference lines shall be adjusted accordingly (see 4.2.1.4).

Panel 3 connects Panels 2 and 4 and shall be perpendicular to them.

Panel 1 shall be perpendicular to and immediately adjacent to Panel 2 with the unattached end located at a maximum horizontal distance of 200 mm from a horizontal line projected forward across the outside face of the rear wheel of the tractor nearest to the flail mower in the test starting position.

4.2.4 Target for an in-line flail mower with extended operator's panel location (see Figure 5)

Dimensions in millimetres

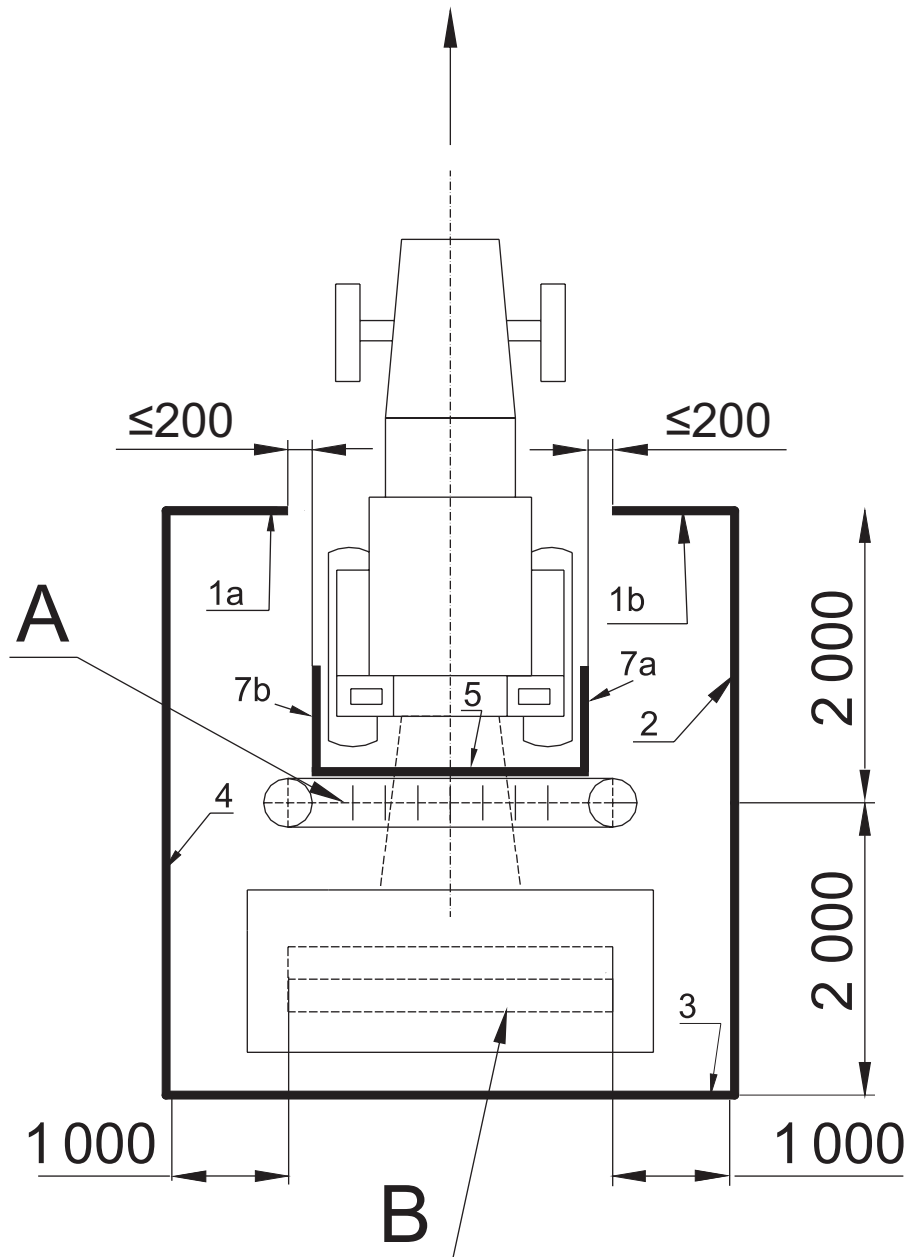

- Key**
- A test material
 - B tool path
 - panels (1a, 1b, 2, 3, 4, 5, 7a, 7b)

Figure 5 — Target panel configuration for an in-line flail mower with extended operator's panel location

The target is made up of six (or eight) panels (Panels 1a, 1b, 2, 3, 4, 5 and, in some cases, 7a and 7b), which shall comply with the specifications of 4.2.1 and 4.2.2.

Panels 7a and 7b shall be used when the cutting width of the flail mower is more than the width of panel 5 or the flail mower can be operated at different working positions (right side, centre or left side of the tractor).

Panels 2 and 4 shall be 4000 mm long. If, due to flail mower dimensions, it is not possible to achieve this length, it may be increased. In this case, Panel 3 shall be located at a maximum horizontal distance of 200 mm from the rear of the flail mower in the test starting position.

Panel 1a shall be perpendicular, and immediately adjacent, to Panel 4, with the unattached end located at a maximum horizontal distance of 200 mm from a horizontal line projected forward across the outside face of the rear wheel of the tractor nearest to Panel 4 in the test starting position or the edge of Panel 5, whichever is wider.

Panel 1b shall be perpendicular, and immediately adjacent, to Panel 2, with the unattached end located at a maximum horizontal distance of 200 mm from a horizontal line projected forward across the outside face of the rear wheel of the tractor nearest to Panel 2 in the test starting position or the edge of Panel 5, whichever is wider.

Panels 2 and 4 shall be parallel to the longitudinal tractor axis and located at a distance of 1 000 mm from the nearest tool path.

Panel 3 connects Panels 2 and 4, and shall be perpendicular to them.

4.2.5 Target for front-mounted flail mowers (see Figure 6)

The target shall be constructed of six panels (Panels 1, 2, 3a, 3b, 4 and 6).

Panels 1 to 4 shall comply with the specifications of 4.2.1.

Panel 6 shall serve as a target at the rear side of the flail mower.

For a mounted flail mower, Panel 6 shall be located in front on an intermediate frame. This frame shall be located between the flail mower and the tractor and at a distance of 500 mm behind the lower link hitch point of the flail mower. The width of Panel 6 shall be equal to the working width of the flail mower and its height shall be 1 000 mm. An adequate opening inside the Panel 6 for the passage of the PTO drive shaft is accepted. Panel 6 shall be placed vertically with its lower edge at a height of 200 mm from the ground.

Panels 2 and 4 shall be 4 000 mm long.

Panel 6 shall be parallel to and at a maximum distance of 200 mm from Panel 3a and Panel 3b.

Panels 2 and 4 shall be parallel to the longitudinal tractor or self-propelled flail-mower axis and located at a distance of 1 000 mm from the nearest tool path.

Panel 1 connects Panels 2 and 4 and shall be perpendicular to them.

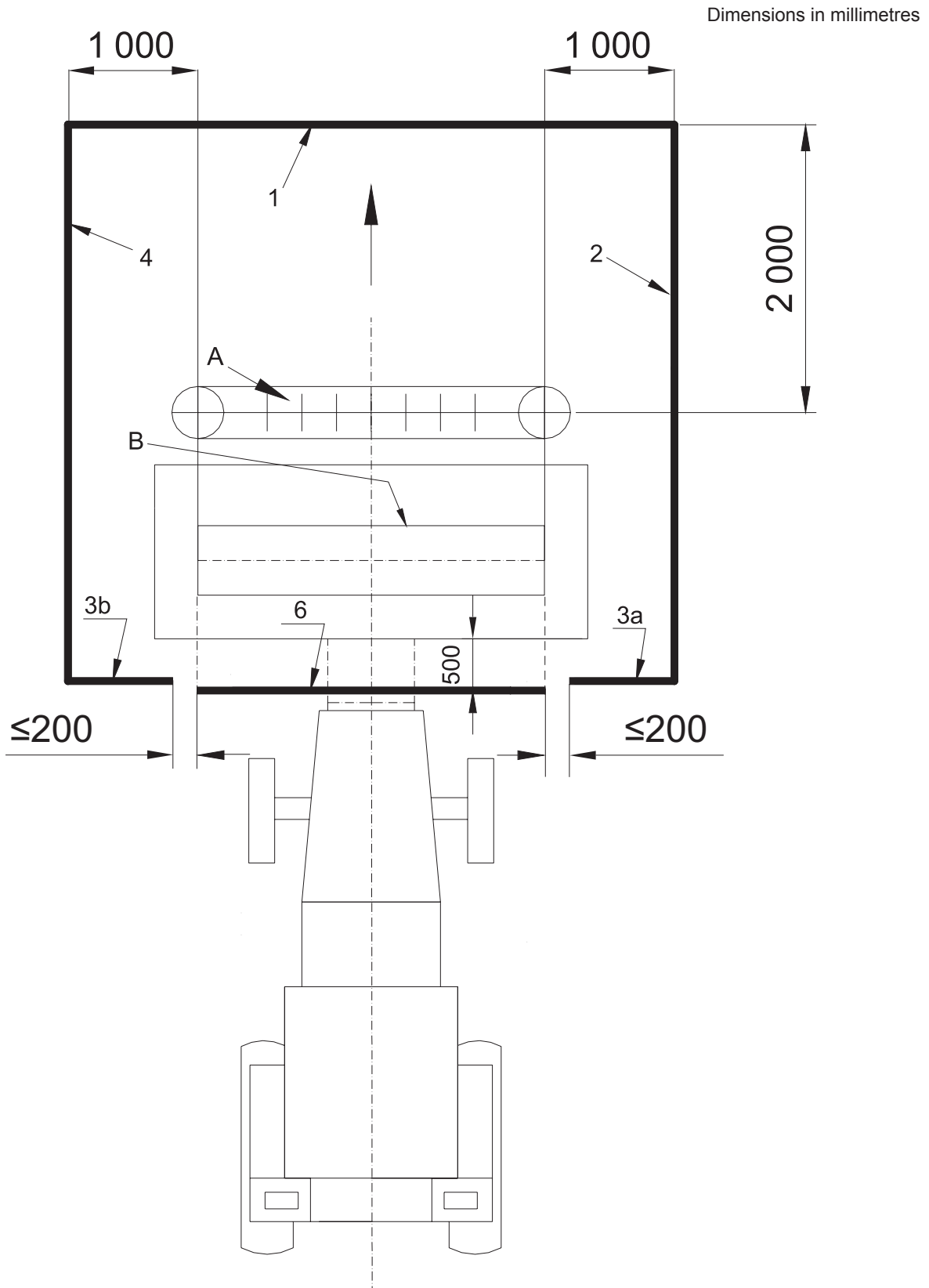

Key

- A test material
- B tool path
- panels (1, 2, 3a, 3b, 4, 6)

Figure 6 — Target panel configuration for a front-mounted flail mower

4.2.6 Target for flail mowers, trailed and semi-mounted (see Figure 7)

The target shall be constructed of six panels (Panels 1, 2, 3, 4, 5 and 7a), which shall comply with the specifications given in 4.2.1 and 4.2.2.

Panels 2 and 4 shall be 4 000 mm long. If, due to the flail-mower dimensions, it is not possible to achieve this length, it may be increased, but Panel 3 shall be located at a maximum horizontal distance of 200 mm from the rear of the flail mower in the test starting position.

Panel 2 shall be parallel to the longitudinal tractor axis and located a distance of 1 000 mm from the nearest tool path.

Panel 4 shall be parallel to Panel 2 and shall be located at a distance of 2 000 mm from the nearest tool path. If, due to the flail-mower dimensions, it is not possible to achieve this length, it may be increased, but Panel 4 shall be located at a maximum horizontal distance of 200 mm from the rear wheel of the tractor or from the edge of Panel 5, whichever is larger. The reference lines shall be adjusted accordingly (see 4.2.1.4).

Panel 3 connects Panels 2 and 4 and shall be perpendicular to them.

Panel 1 shall be perpendicular to and immediately adjacent to Panel 2 with the unattached end located at a maximum horizontal distance of 200 mm from a horizontal line projected forward across the outside face of the rear wheel of the tractor nearest to Panel 2 in the starting position or from Panel 7a, whichever is larger.

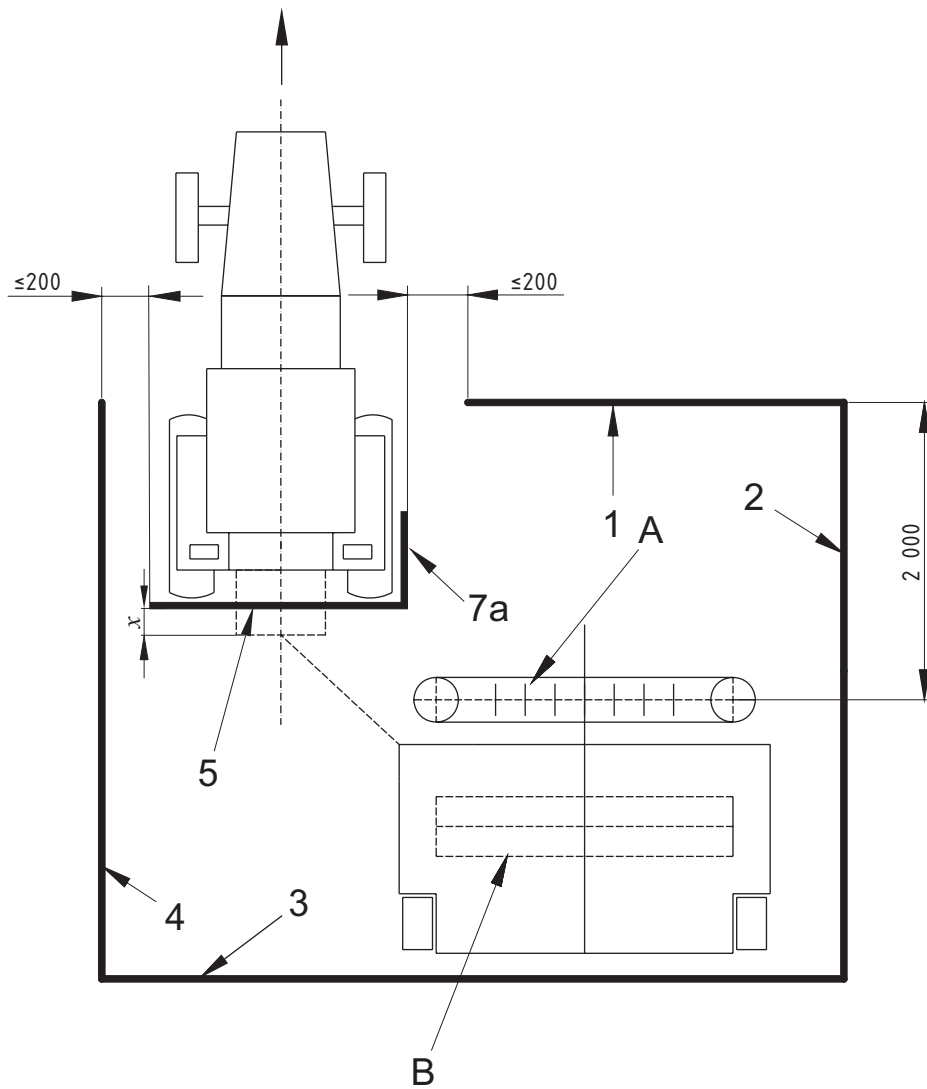

Key

A test material

B tool path

x = 600 mm or 800 mm (see 4.2.2)

— panels (1, 2, 3, 4, 5, 7a)

Figure 7 — Target panel configuration for trailed and semi-mounted flail mowers

4.2.7 Target for trailed flail mowers, which are functional either to the right side, centre or to the left side of the tractor (see Figure 8)

The target shall be constructed of seven panels (Panels 1, 2, 3, 4, 5, 7a and 7b) which shall comply with the specifications of 4.2.1 and 4.2.2. Figure 8 a) shows the target for the flail mower operated at the rightmost position and Figure 8 b) shows the target for the flail mower operated in the leftmost position.

Panel 2 shall be 6 000 mm long, located at a distance of 1 000 mm from the nearest tool path and parallel to the longitudinal axis of the tractor. If, due to flail mower dimensions, it is not possible to achieve this length, it may be increased, but Panel 3 shall be located at a maximum horizontal distance of 200 mm from the rear of the flail mower in the test starting position.

Panel 4 shall be parallel to Panel 2 and shall be located at a distance of 2 000 mm from the nearest tool path. The length of Panel 4 shall be equal to or greater than the length of Panel 2. If, due to flail mower dimensions, it is not possible to achieve this length for Panel 4, it may be increased. In this case, Panel 4 shall be extended towards the tractor parallel to the longitudinal axis of the tractor and terminate at a maximum distance of 200 mm from the drawbar of the flail mower or Panel 5 in the test starting position.

Panel 3 connects Panels 2 and 4 and shall be perpendicular to them.

Panel 1 shall be perpendicular to Panels 2 and 4 and connect at the end of Panel 2. The length of Panel 1 shall be adjusted so that the whole working width of the flail mower is covered. If, due to the dimensions of the flail mower and the drawbar, it is not possible to achieve this, then Panel 1 shall be adjusted so that the drawbar stops within 200 mm (but not in contact with Panel 1) at the conclusion of the test run. If Panel 1 does not intersect the path of the drawbar, then it shall terminate at a maximum horizontal distance of 200 mm from Panel 4.

The opening between the ends of Panels 1 and 4 is acceptable for the passage of the drawbar.

Adjustments to reference lines shall be made according to 4.2.1.4.

Dimensions in millimetres

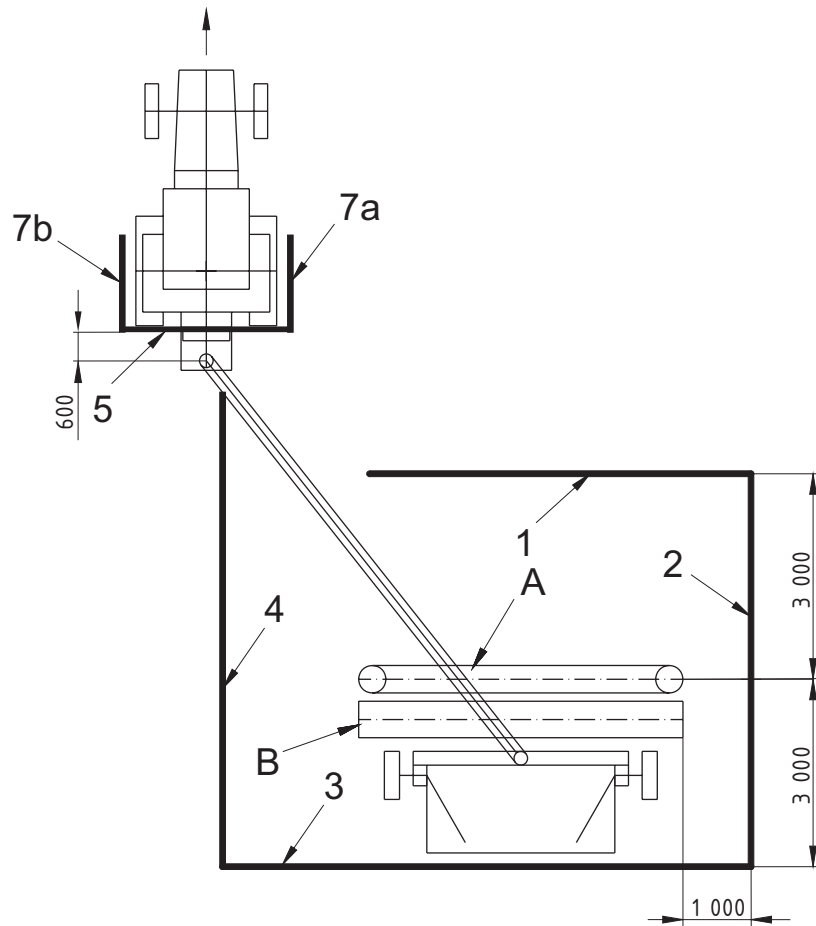

a) Target panel configuration for a trailed flail mower (right side)

Figure 8 (continued on the next page)

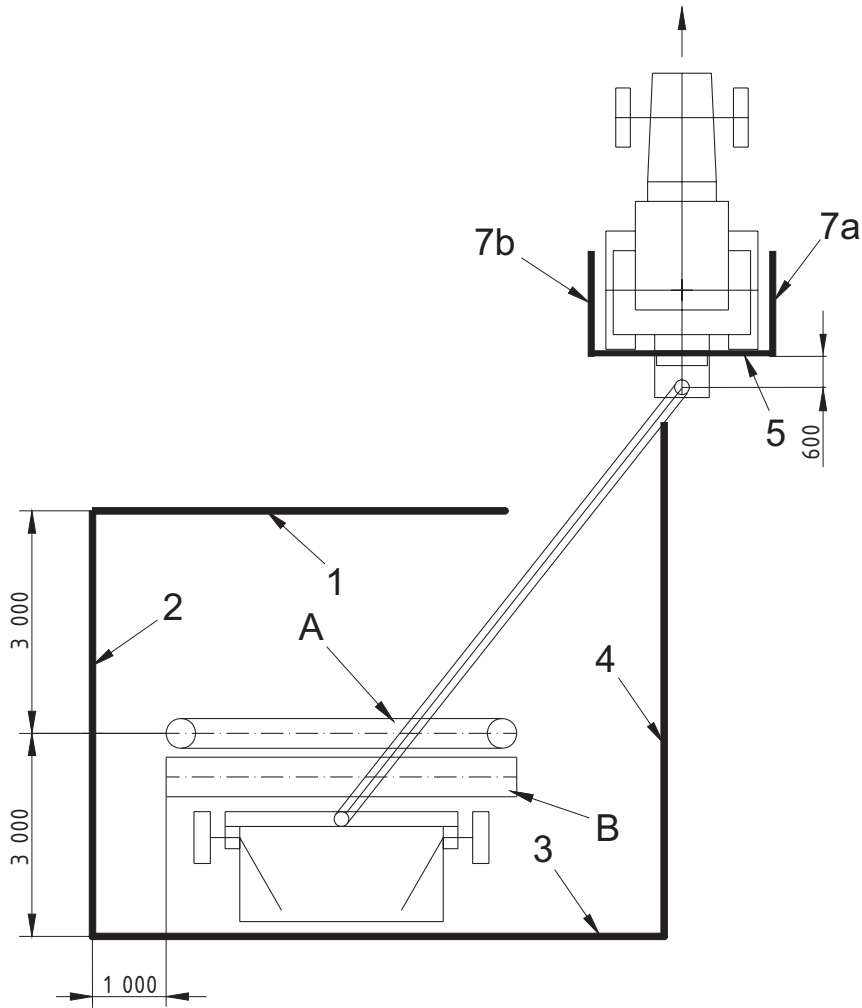

b) Target panel configuration for a trailed flail mower (left side)

Key

- A test material
- B tool path
- panels (1, 2, 3, 4, 5, 7a, 7b)

Figure 8 — Target panel configuration for a trailed flailed mower

4.3 Test material

4.3.1 Test material preparation

The mixture used as projectile material shall be made up by volume of

- 50 % sand (natural, crushed, or uncrushed),
- 25 % gravel of mixture of grain size 8 mm to 16 mm (excluded), and
- 25 % gravel of mixture of grain size 16 mm to 32 mm (excluded).

4.3.2 Moisture for test material

The test material shall be humidified to reach saturation point and be kept damp during the test. The mixture shall be homogeneous.

4.3.3 Test material configuration

The test material mixture described in 4.3.1 shall be placed in front of the flail mower, perpendicular to the forward direction to form conical piles (150 ± 5 mm high or 100 mm higher than the flail-mower cutting height). Each pile shall consist of 10 l (or $0,01 \text{ m}^3$) of the material. This may be achieved for example by using a device as shown in Figure 9.

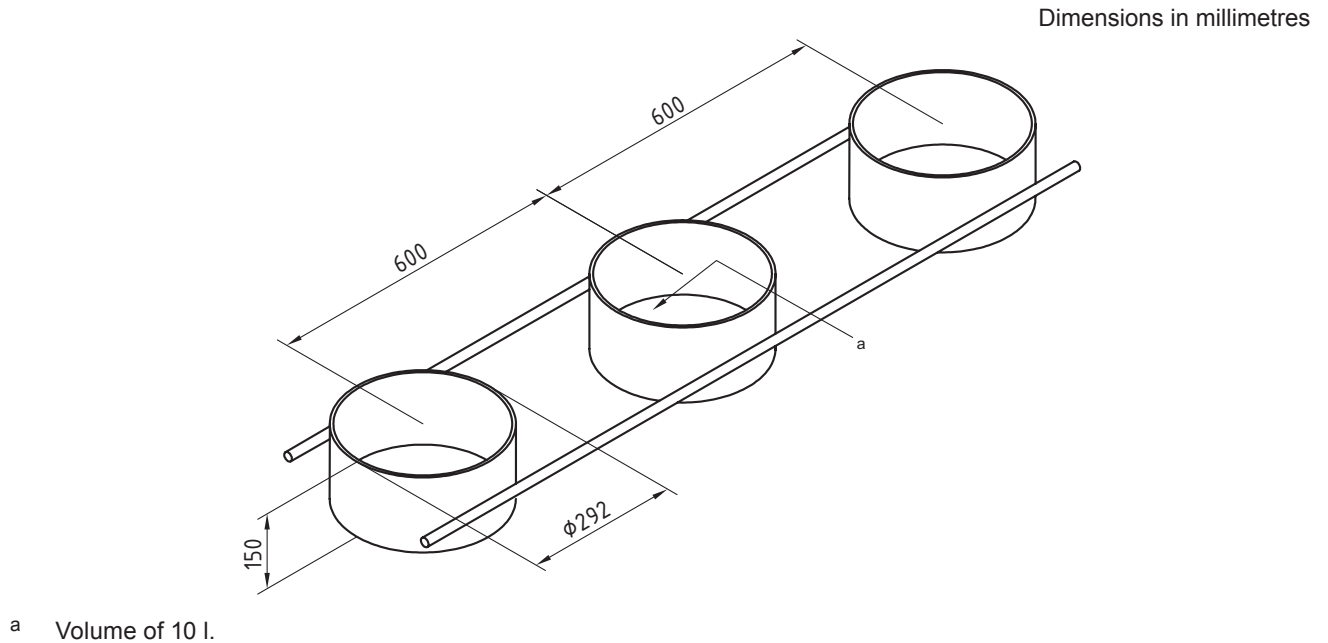

Figure 9 — Example of conical pile location device

4.4 Test run conditions

4.4.1 Test PTO rotation speed

During tests, the flail mowers shall be driven operated at the PTO speed recommended by the manufacturer (e.g. at power take-off speed of 540 min^{-1} or $1\,000 \text{ min}^{-1}$) utilizing a tractor with minimum power at least equal to the minimum power take-off needed for the flail mower measured according to ISO 789-1:1990.

4.4.2 Test forward speed

During tests, the flail mowers shall be moved with a forward speed so that the tools run through the test material with a forward speed from 2 km/h to 4 km/h.

4.4.3 Mower positioning

The flail mower shall be placed as close as possible to the piles of test material.

4.5 Test procedure

- a) At the beginning of each test, the target shall not show any impact other than in the lower zone.
- b) The test shall be performed two times and each test will be comprised of two runs.
 - 1) For the first run, piles 1-3-5, etc. shall be put in place [see Figure 10 a)].
 - 2) For the second run, piles 2-4-6, etc. shall be put in place [see Figure 10 b)].
- c) The number of piles used for the test shall be dependent on the flail mower cutting width.
- d) The centre of the pile n°1 shall be placed on the external limit of the tools path.
- e) The centre of the pile n°2 shall be placed at a distance of 300 mm from the external limit of the tools path.
- f) The centre of the last pile shall be placed outside the tools path.
- g) When the flail mower reaches the nominal rotational speed recommended by the manufacturer, a run shall be made through the test material.
- h) After each run, impacts on the panels shall be marked in order to differentiate them.
- i) After each run, the test material shall be removed from the coconut matting in order to achieve the starting conditions as described in 4.1.2.
- j) The test material shall be changed after each test.

Dimensions in millimetres

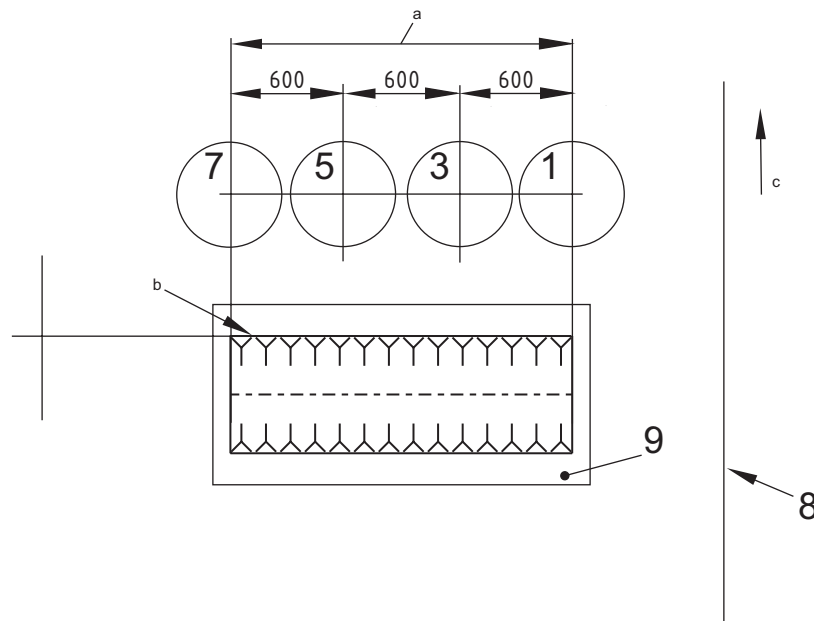

a) Placing of test material, first run

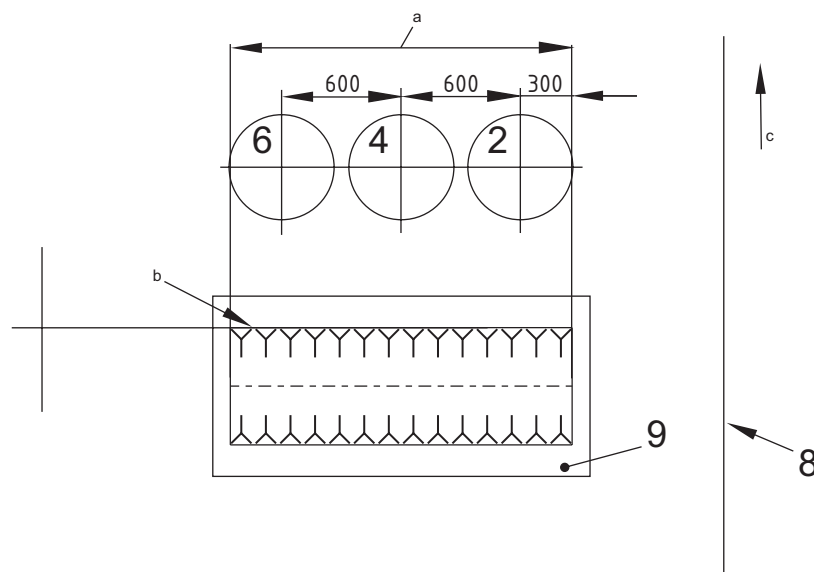

b) Placing of test material, second run

Key

- 1-7 conical piles
- 8 panel
- 9 upper guard
- a Cutting width.
- b Tool path.
- c Forward direction.

Figure 10 — Target material pile locations

4.6 Test results and report

The impacts of each run shall be recorded and included in the report. (See Annex B for an example report.)

The test report shall specify the type of test material that has been used for the test (natural, crushed, or uncrushed).

4.7 Acceptance criteria

4.7.1 When the results of the first two tests are positive, the flail mower is considered to have fulfilled the thrown object test requirement.

4.7.2 If the results of one of the first two tests are not positive, two additional tests shall be carried out. If the test results of these tests are positive, the flail mower is considered to have fulfilled the thrown-object test requirement.

4.7.3 The results of one test requirements are considered to be acceptable when the following conditions are satisfied.

- In the upper zone, there shall be no impact.
- In the operator's zone, there shall be no impact.
- In the middle zone, there shall be no more than two impacts per 1 000 mm vertical section.
- In the middle zone, there shall be no more than 1,5 impacts per m².

NOTE It is not necessary to count impacts in the lower zone; these impacts do not have an effect of test acceptance.

Annex A (informative)

Illustrations of mowers

A.1 Mowers dealt with in this International Standard

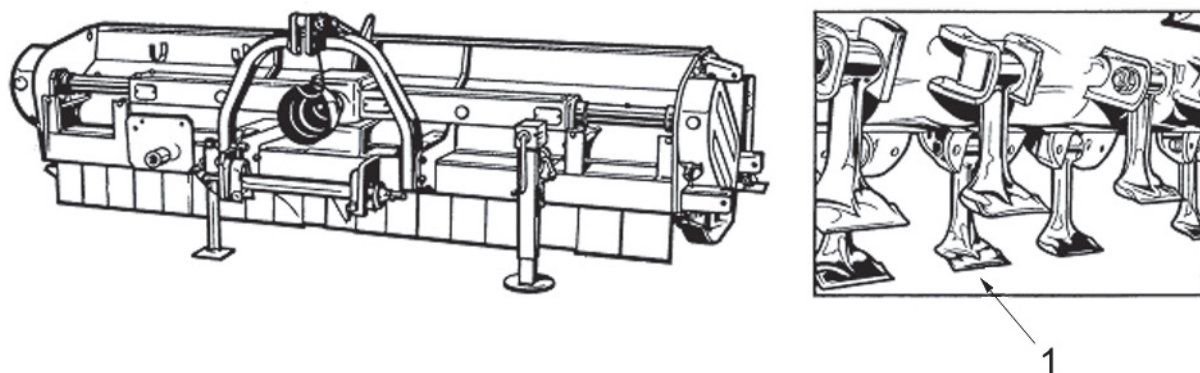

Key
1 tool

Figure A.1 — Flail mower

A.2 Mowers not dealt with in this International Standard



Figure A.2 — Self-propelled mower

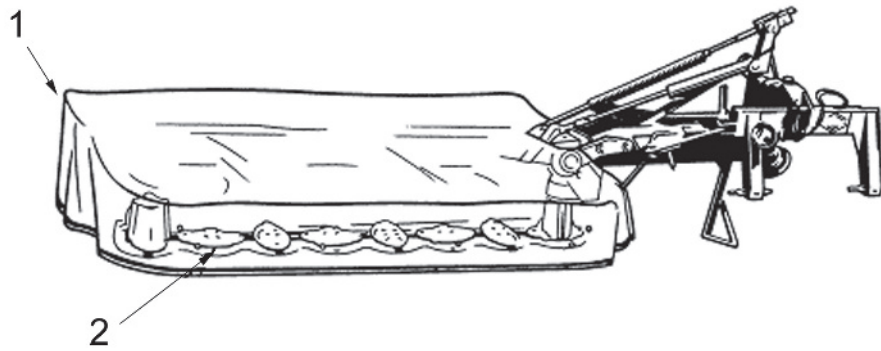

Key

- 1 protective skirt
- 2 cutting head

Figure A.3 — Basic rotary disc mower

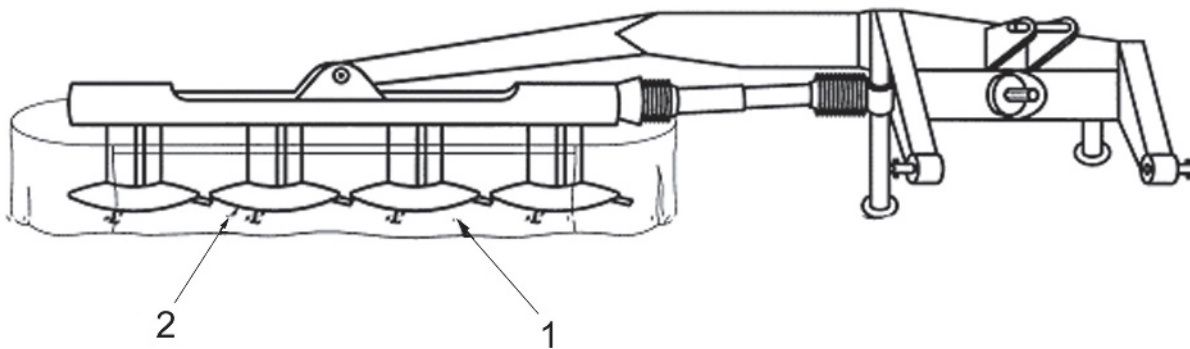

Key

- 1 protective skirt
- 2 cutting head

Figure A.4 — Basic rotary drum mower

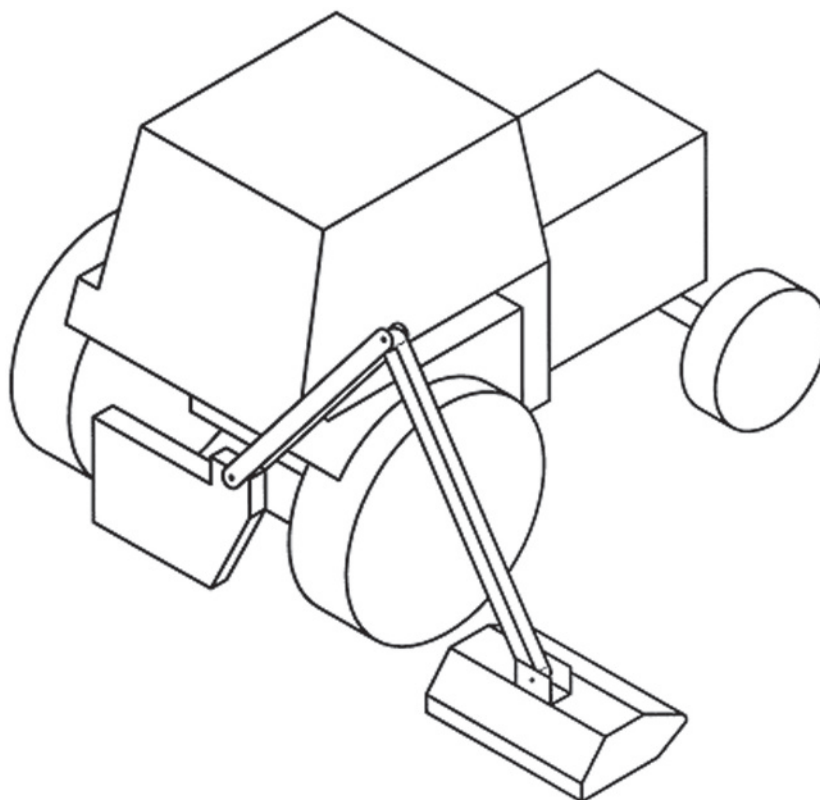

Figure A.5 — Mower with an articulated arm

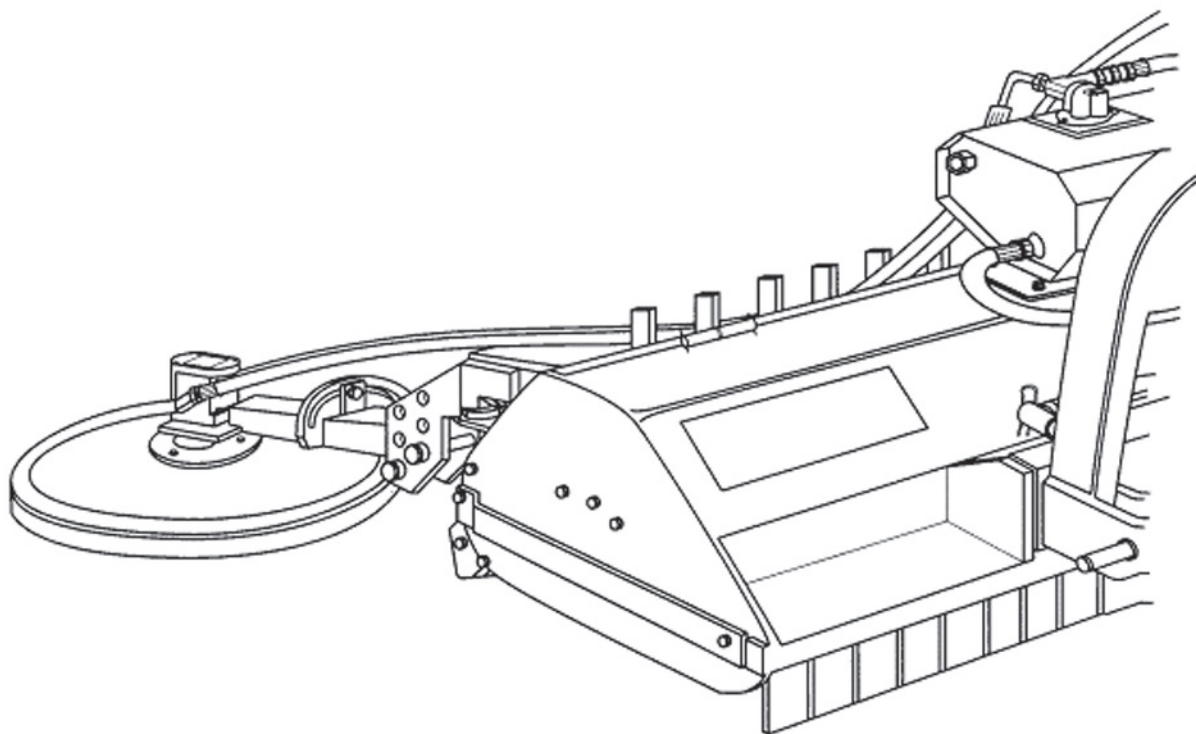

Figure A.6 — Inter-row mowing unit

Annex B
 (informative)

ISO 17101-2 Thrown-object test reports — Flail mowers

B.1 Specifications

Flail mower specifications	
Manufacturer:	
Designation:	
Type:	
Serial number:	
Year of construction:	
Mounting configuration:	
Mowing width:	
Protective devices [rear, front]:	
PTO speed [min^{-1}]:	
Max. rotor speed of flail shaft [min^{-1}]:	
Hydraulic pressure [bar]:	
Type of cutting tools:	
Quantity of cutting tools [pieces]:	
Maximum permissible power consumption [kW]:	

Vehicle specifications:					
Manufacturer:					
Designation:					
Type:					
Maximum weight [kg]:					
Performance [kW]:					
Target panels see figure:	5 <input type="checkbox"/>	6 <input type="checkbox"/>	7 <input type="checkbox"/>	8a <input type="checkbox"/>	8b <input type="checkbox"/>

B.2 Primary tests report

1. Test

2. Test

Panel	Vertical section	Reference line					Reference line				
		Middle zone Σ Max. 2 Impacts/section			Upper zone 0 Impacts		Middle zone Σ Max. 2 Impacts/section			Upper zone 0 Impacts	
		1. Run	2. Run	Σ	1. Run	2. Run	1. Run	2. Run	Σ	1. Run	2. Run
1	1.1										
	1.2										
	1.3										
	1.4										
	1.5										
	1.6										
2	2.1										
	2.2										
	2.3										
	2.4										
3	3.1										
	3.2										
	3.3										
	3.4										
	3.5										
	3.6										
4	4.1										
	4.2										
	4.3										
	4.4										
6	6.1										
	6.2										
	6.3										
	6.4										
Middle Zone		Average = Impacts/Target Area [m²] Σ Max. 1,5 to pass					Average = Impacts/Target Area [m²] Σ Max. 1,5 to pass				
		Pass					Pass				
		Fail					Fail				

		1. Test		2. Test	
Panel	Operator's zone		Operator's zone		
	0 Impacts		0 Impacts		
	1. Run	2. Run	1. Run	2. Run	
5					
7a					
7b					

Not applicable	<input type="checkbox"/>	Not applicable	<input type="checkbox"/>
Pass	<input type="checkbox"/>	Pass	<input type="checkbox"/>
Fail	<input type="checkbox"/>	Fail	<input type="checkbox"/>

The thrown-object test shown in ISO 17101-2 has been passed/failed.

Test location, Date

Approved by

B.3 Additional tests report

1. Additional Test

2. Additional Test

Panel	Vertical section	Reference line					Reference line				
		Middle zone Σ Max. 2 Impacts/section			Upper zone 0 Impacts		Middle zone Σ Max. 2 Impacts/section			Upper zone 0 Impacts	
		1. Run	2. Run	Σ	1. Run	2. Run	1. Run	2. Run	Σ	1. Run	2. Run
1	1.1										
	1.2										
	1.3										
	1.4										
	1.5										
	1.6										
2	2.1										
	2.2										
	2.3										
	2.4										
3	3.1										
	3.2										
	3.3										
	3.4										
	3.5										
	3.6										
4	4.1										
	4.2										
	4.3										
	4.4										
6	6.1										
	6.2										
	6.3										
	6.4										
Middle Zone		Average = Impacts/Target Area [m²] Σ Max. 1,5 to pass					Average = Impacts/Target Area [m²] Σ Max. 1,5 to pass				
		Pass					Pass				
		<input type="checkbox"/>					<input type="checkbox"/>				
		Fail					Fail				
		<input type="checkbox"/>					<input type="checkbox"/>				

Panel	1. Additional Test		2. Additional Test	
	Operator's zone 0 Impacts		Operator's zone 0 Impacts	
	1. Run	2. Run	1. Run	2. Run
5				
7a				
7b				

Not applicable	<input type="checkbox"/>	Not applicable	<input type="checkbox"/>
Pass	<input type="checkbox"/>	Pass	<input type="checkbox"/>
Fail	<input type="checkbox"/>	Fail	<input type="checkbox"/>

The thrown-object test shown in ISO 17101-2 has been passed/failed.

Test location, Date

Approved by

Bibliography

- [1] ISO 4254-12:2012, *Agricultural machinery — Safety — Part 12: Rotary disc and drum mowers and flail mowers*

British Standards Institution (BSI)

BSI is the national body responsible for preparing British Standards and other standards-related publications, information and services.

BSI is incorporated by Royal Charter. British Standards and other standardization products are published by BSI Standards Limited.

About us

We bring together business, industry, government, consumers, innovators and others to shape their combined experience and expertise into standards-based solutions.

The knowledge embodied in our standards has been carefully assembled in a dependable format and refined through our open consultation process. Organizations of all sizes and across all sectors choose standards to help them achieve their goals.

Information on standards

We can provide you with the knowledge that your organization needs to succeed. Find out more about British Standards by visiting our website at bsigroup.com/standards or contacting our Customer Services team or Knowledge Centre.

Buying standards

You can buy and download PDF versions of BSI publications, including British and adopted European and international standards, through our website at bsigroup.com/shop, where hard copies can also be purchased.

If you need international and foreign standards from other Standards Development Organizations, hard copies can be ordered from our Customer Services team.

Subscriptions

Our range of subscription services are designed to make using standards easier for you. For further information on our subscription products go to bsigroup.com/subscriptions.

With **British Standards Online (BSOL)** you'll have instant access to over 55,000 British and adopted European and international standards from your desktop. It's available 24/7 and is refreshed daily so you'll always be up to date.

You can keep in touch with standards developments and receive substantial discounts on the purchase price of standards, both in single copy and subscription format, by becoming a **BSI Subscribing Member**.

PLUS is an updating service exclusive to BSI Subscribing Members. You will automatically receive the latest hard copy of your standards when they're revised or replaced.

To find out more about becoming a BSI Subscribing Member and the benefits of membership, please visit bsigroup.com/shop.

With a **Multi-User Network Licence (MUNL)** you are able to host standards publications on your intranet. Licences can cover as few or as many users as you wish. With updates supplied as soon as they're available, you can be sure your documentation is current. For further information, email bsmusales@bsigroup.com.

BSI Group Headquarters

389 Chiswick High Road London W4 4AL UK

Revisions

Our British Standards and other publications are updated by amendment or revision.

We continually improve the quality of our products and services to benefit your business. If you find an inaccuracy or ambiguity within a British Standard or other BSI publication please inform the Knowledge Centre.

Copyright

All the data, software and documentation set out in all British Standards and other BSI publications are the property of and copyrighted by BSI, or some person or entity that owns copyright in the information used (such as the international standardization bodies) and has formally licensed such information to BSI for commercial publication and use. Except as permitted under the Copyright, Designs and Patents Act 1988 no extract may be reproduced, stored in a retrieval system or transmitted in any form or by any means – electronic, photocopying, recording or otherwise – without prior written permission from BSI. Details and advice can be obtained from the Copyright & Licensing Department.

Useful Contacts:

Customer Services

Tel: +44 845 086 9001

Email (orders): orders@bsigroup.com

Email (enquiries): cservices@bsigroup.com

Subscriptions

Tel: +44 845 086 9001

Email: subscriptions@bsigroup.com

Knowledge Centre

Tel: +44 20 8996 7004

Email: knowledgecentre@bsigroup.com

Copyright & Licensing

Tel: +44 20 8996 7070

Email: copyright@bsigroup.com



...making excellence a habit.™