

BS ISO 16964:2015



BSI Standards Publication

Gas cylinders — Flexible hoses assemblies — Specification and testing

bsi.

...making excellence a habit.™

National foreword

This British Standard is the UK implementation of ISO 16964:2015.

The UK participation in its preparation was entrusted to Technical Committee PVE/3/1, Gas containers - Valve fittings for gas containers.

A list of organizations represented on this committee can be obtained on request to its secretary.

This publication does not purport to include all the necessary provisions of a contract. Users are responsible for its correct application.

© The British Standards Institution 2015.
Published by BSI Standards Limited 2015

ISBN 978 0 580 75508 8

ICS 23.020.30; 83.140.40

Compliance with a British Standard cannot confer immunity from legal obligations.

This British Standard was published under the authority of the Standards Policy and Strategy Committee on 31 October 2015.

Amendments/corrigenda issued since publication

| Date | Text affected |
|------|---------------|
|------|---------------|

INTERNATIONAL
STANDARD

ISO
16964

First edition
2015-09-15

**Gas cylinders — Flexible hoses
assemblies — Specification and testing**

Bouteilles à gaz — Flexibles — Spécifications et essais



Reference number
ISO 16964:2015(E)

© ISO 2015



COPYRIGHT PROTECTED DOCUMENT

© ISO 2015, Published in Switzerland

All rights reserved. Unless otherwise specified, no part of this publication may be reproduced or utilized otherwise in any form or by any means, electronic or mechanical, including photocopying, or posting on the internet or an intranet, without prior written permission. Permission can be requested from either ISO at the address below or ISO's member body in the country of the requester.

ISO copyright office
Ch. de Blandonnet 8 • CP 401
CH-1214 Vernier, Geneva, Switzerland
Tel. +41 22 749 01 11
Fax +41 22 749 09 47
copyright@iso.org
www.iso.org

Contents

Page

| | |
|---|-----------|
| Foreword | iv |
| Introduction | v |
| 1 Scope | 1 |
| 2 Normative references | 1 |
| 3 Terms and definitions | 1 |
| 4 Requirements | 2 |
| 4.1 Production pressure tests..... | 2 |
| 4.1.1 Strength test..... | 2 |
| 4.1.2 Leak test..... | 2 |
| 4.2 Type tests..... | 2 |
| 4.2.1 General..... | 2 |
| 4.2.2 Burst pressure test (3 samples per type)..... | 2 |
| 4.2.3 Pressure cycle test (3 samples per type)..... | 3 |
| 4.2.4 Oxygen compatibility test (3 samples per type)..... | 4 |
| 4.2.5 Acetylene compatibility test (3 samples)..... | 4 |
| 4.2.6 Gas material compatibility..... | 4 |
| 4.2.7 Test of the safety cable (2 samples)..... | 4 |
| 4.2.8 Additional tests (see Annex A)..... | 4 |
| 5 Marking | 6 |
| Annex A (normative) Examples of kink test, side impact test and torsion test | 7 |
| Bibliography | 13 |

Foreword

ISO (the International Organization for Standardization) is a worldwide federation of national standards bodies (ISO member bodies). The work of preparing International Standards is normally carried out through ISO technical committees. Each member body interested in a subject for which a technical committee has been established has the right to be represented on that committee. International organizations, governmental and non-governmental, in liaison with ISO, also take part in the work. ISO collaborates closely with the International Electrotechnical Commission (IEC) on all matters of electrotechnical standardization.

The procedures used to develop this document and those intended for its further maintenance are described in the ISO/IEC Directives, Part 1. In particular the different approval criteria needed for the different types of ISO documents should be noted. This document was drafted in accordance with the editorial rules of the ISO/IEC Directives, Part 2 (see www.iso.org/directives).

Attention is drawn to the possibility that some of the elements of this document may be the subject of patent rights. ISO shall not be held responsible for identifying any or all such patent rights. Details of any patent rights identified during the development of the document will be in the Introduction and/or on the ISO list of patent declarations received (see www.iso.org/patents).

Any trade name used in this document is information given for the convenience of users and does not constitute an endorsement.

For an explanation on the meaning of ISO specific terms and expressions related to conformity assessment, as well as information about ISO's adherence to the WTO principles in the Technical Barriers to Trade (TBT) see the following URL: [Foreword - Supplementary information](#)

The committee responsible for this document is ISO/TC 58, *Gas cylinders*, Subcommittee SC 2, *Cylinder fittings*.

Introduction

Flexible hose assemblies are used to transfer industrial and medical gases into cylinders, bundles and trailers and also to supply such gases to user equipment.

There is a range of existing International Standards to be used for specific applications or hose construction:

- ISO 14113 which covers hoses made with internal rubber or plastics tubing and used to supply gases to customers for welding applications;
- ISO 21969 which covers hoses with an internal corrugated metallic liner and used to supply medical gases to customers;
- ISO 10380 which covers hoses with internal corrugated metallic liner for all applications including non-industrial and medical gases.

ISO 14113 and ISO 21969 cover only specific customer applications and are intended to be used accordingly, while ISO 10380 is general in its approach.

The purposes of this International Standard are:

- to provide the specification and testing requirements for high pressure flexible hose assemblies intended to be connected at filling pressure to cylinders, cylinder bundles or trailers for use when filling and emptying gas at production sites and also where the customer is connecting directly to the cylinder valve, e.g. a cylinder to manifold connection
- to cover the applications not described by the above International Standards, (flexible hose assemblies for filling centres, flexible hose assemblies for all customer applications),
- to specify a new range of testing requirements which will more effectively evaluate the ability of flexible hose assemblies to remain safe in operation. These test requirements replace the traditional reliance on having a high ratio between rated pressure and burst pressure.

Gas cylinders — Flexible hoses assemblies — Specification and testing

1 Scope

This International Standard provides specification and testing requirements for high pressure flexible hose assemblies intended to be connected to gas cylinders, bundles of cylinders or trailers for use when filling and emptying gas at production sites and also for customer use. This International Standard applies to flexible hose assemblies with rated pressures up to 1 000 bar for use in the temperature range of -40°C to $+65^{\circ}\text{C}$.

This International Standard is not applicable to:

- rubber and plastics flexible hose assemblies for welding, cutting and related processes up to 45 MPa (450 bar) for customer use (see ISO 14113);
- high pressure flexible hose assemblies for use with medical gas systems for customer use (see ISO 21969);
- low pressure hose assemblies for use with medical gases, for customer use (see ISO 5359);
- rubber and thermoplastic low pressure hose assemblies for welding, cutting and related processes for customer use (see ISO 3821 or ISO 12170);
- flexible hose assemblies for cryogenic applications (see ISO 21012);
- flexible hose assemblies for liquid petroleum gas (LPG).

NOTE Flexible hose assembly designs which pass the type test approval test described in this International Standard can have a lower ratio of burst pressure to rated pressure than stated in other standards.

2 Normative references

The following documents, in whole or in part, are normatively referenced in this document and are indispensable for its application. For dated references, only the edition cited applies. For undated references, the latest edition of the referenced document (including any amendments) applies.

ISO 148-1, *Metallic materials — Charpy pendulum impact test — Part 1: Test method*

ISO 1402, *Rubber and plastics hoses and hose assemblies — Hydrostatic testing*

ISO 10286, *Gas cylinders — Terminology*

ISO 10380, *Pipework — Corrugated metal hoses and hose assemblies*

ISO 14113:2013, *Gas welding equipment — Rubber and plastics hose and hose assemblies for use with industrial gases up to 450 bar (45 MPa)*

ISO 21969:2009, *High-pressure flexible connections for use with medical gas systems*

3 Terms and definitions

For the purposes of this document, the terms and definitions given in ISO 10286, ISO 1402, ISO 14113, ISO 10380, ISO 21969 and the following apply.

3.1 rated pressure PR

rated pressure of a hose assembly is equal to: $PR = 1,25 PW$, PW being the working pressure of the cylinder as defined in ISO 10286

Note 1 to entry: National and international design codes for pressure systems can specify a higher value of rated pressure.

Note 2 to entry: When cylinders are filled or emptied, the gas temperature could be higher than 15 °C. This is the reason why the rated pressure is higher than the cylinder working pressure.

3.2 burst pressure

highest pressure reached in a flexible hose assembly during a burst test

4 Requirements

4.1 Production pressure tests

4.1.1 Strength test

Each flexible hose assembly shall first be subjected to a strength test using oil-free water at a pressure at least equal to 1,5 times the rated pressure, PR , for a minimum of 3 min. There shall be no visible sign of leakage, permanent deformation or other sign of failure. Where hydraulic testing would result in unacceptable contamination of the flexible hose assembly, the hydraulic test may be replaced by a pneumatic test using a compatible medium such as dry oil-free air or nitrogen. Appropriate safety measures shall be taken to protect personnel and equipment during testing.

4.1.2 Leak test

The flexible hose assembly shall be leak tested by pressurizing at PR with compressed dry oil-free air, nitrogen or other test gases. The leak rate shall be less than 6 cm³/h.

4.2 Type tests

4.2.1 General

All test samples shall be manufactured to the same design, material specification and from the same batch of raw material. Records of the tests performed are to be retained by the flexible hose assembly manufacturer.

To carry out the tests described in this International Standard, it is recommended that the nominal length of hose between end fittings be 1 000 mm unless otherwise specified.

Before being type tested, all sample flexible hose assemblies shall be subjected to production pressure tests as specified in [4.1](#).

For hoses to be used in hydrogen or helium service, the leak test in [4.1.2](#) shall be carried out using helium.

Tests shall be performed at ambient temperature.

4.2.2 Burst pressure test (3 samples per type)

The flexible hose assembly complete with safety cable and clamps (if applicable), is to be hydraulically pressurized until burst occurs. The pressurization rate shall be adjusted at the beginning of the test to be approximately constant and to reach the burst pressure in not less than 1 min.

The burst pressure of the flexible hoses assemblies shall not be less than $3 \times PR$ for a value of PR less than 480 bar and $[(2 \times PR) + 480]$ bar for a value of PR greater than or equal to 480 bar.

If compliance is required with ISO 21969:2009, 6.2.3, a 5 min hold step at $3 \times PW$, where PW is the working pressure, should be performed.

NOTE For acetylene service, hose with a higher burst pressure can be necessary in order to pass the decomposition test described in 4.2.5 for acetylene flexible hose assemblies. The minimum burst pressure for this type of hose is to be stated by the hose manufacturer.

4.2.3 Pressure cycle test (3 samples per type)

4.2.3.1 General

The flexible hose assembly complete with safety cable and clamps (if applicable) shall be submitted to a hydraulic pressurization endurance test from a nominal atmospheric pressure (5 bar maximum) to the PR at a frequency of no more than 30 cycles per minute.

A pressure cycle consists of a pressure increase starting from a pressure not more than 5 bar to PR and a pressure decrease from PR back to the start condition.

This endurance test shall not apply to acetylene flexible hose assemblies because the construction of these hoses is designed to resist extremely high pressure and stress compared to acetylene's low working pressure PW.

4.2.3.2 General requirement

It shall be checked that the entire flexible hose assembly is exposed to a pressure cycle where the maximum pressure is the rated pressure (PR) and the minimum of each pressure cycle is no more than 5 bar. The flexible hose assemblies shall not leak or burst during the test:

- **Category A:** 5 000 pressure cycles for flexible hose assemblies dedicated to non-filling applications such as customer installations. This applies to flexible hose assemblies with metallic and non-metallic liners.
- **Category B:** 50 000 pressure cycles for flexible hose assemblies with non-metallic liners dedicated to filling centres.

4.2.3.3 Specific requirements for metallic hoses used in filling centres

The pressure cycle test shall be performed on hose assemblies with a maximum of 50 000 cycles. No failure should occur before 10 000 cycles.

A simple leak is accepted above 10 000 cycles, but in such cases the life of the hose shall be limited proportionally to its performance in this hydraulic pressure cycling test.

Hoses not able to pass the 10 000 pressure cycles minimum requirement, but demonstrating by this test a non-hazardous failure mode, can be used in service following risk assessment provided that the risk assessment includes as a minimum:

- the definition of a specific application;
- the mode of failure of the hose and any mitigation;
- the associated risk created by the escape of gas;
- the protection of personnel.

Following such risk assessment the life span for the hose can be determined (e.g. use for a given time or until the flexible hose assembly leaks).

If the test has been completed before any leak has been detected (e.g. after 50 000 cycles) then the flexible hose assembly shall be pressurized at PR with compressed dry oil-free air or nitrogen to check for leaks. The leak rate shall be less than 6 cm³ /h. For hoses to be used in hydrogen or helium service, the leak test shall be carried out using helium.

4.2.4 Oxygen compatibility test (3 samples per type)

This test shall be performed for all oxygen applications. Follow the procedure given in ISO 21969:2009, 6.2.4.

4.2.5 Acetylene compatibility test (3 samples)

This test shall be performed for all acetylene applications. Follow the procedure given in ISO 14113:2013, 7.1.2.

Flexible hose assemblies passing this test should be marked "C2H2".

4.2.6 Gas material compatibility

All materials in contact with the gases shall be compatible within the intended pressure and temperature range of the gas application. Use for guidance the requirements of ISO 11114-1 and ISO 11114-2 as applicable.

4.2.7 Test of the safety cable (2 samples)

4.2.7.1 General

This test shall be performed if the flexible hose assembly is equipped with a safety cable. For safety reasons, it is recommended to perform this test in a cage to protect personnel. The hose and the cable shall be fixed between horizontal fixed points which are separated by a distance equal to 75 % of the length of the hose so that the hose has a gentle bend and is not tight between the fixed points.

4.2.7.2 Test 1

The flexible hose assembly is severed by drilling a hole at mid length on one side without damaging the safety cable or disturbing the clamps. The diameter of the drilled hole shall be equal to 80 % of the internal nominal diameter (DN) on the flexible hose assembly. Air or nitrogen is admitted at PR via a quick opening valve into the hose through one of the end fittings. The gas supplied is cut off not less than 10 s after opening. The cable and its fixings shall be intact and the clamps shall have remained in their original positions on the hose. Their location is recorded before and after testing. A movement of ± 2,5 cm along the hose is accepted. The clamps shall remain fixed on the cable but their location might be different.

4.2.7.3 Test 2

A similar test is performed if the safety cable is secured to the hose end fittings. In this case the flexible hose assembly is severed by drilling the same size hole as test 1 but immediately adjacent to the end fitting at the opposite end of the hose to where the test gas is admitted. The same acceptance criteria as in test 1 shall be used.

If the safety cable is designed to be anchored separately to the hose end fitting the test is performed with the same requirements and acceptance criteria as above but with the end adjacent of the drilling plugged and not anchored.

4.2.8 Additional tests (see [Annex A](#))

These tests are part of the type tests when listed as mandatory in the following subclauses.

4.2.8.1 Kink test (1 sample) (see [A.1](#))

This test is mandatory for non-metallic lined flexible hose assemblies except when other kink prevention safety measures are in place (e.g. external spring protection).

NOTE This test is normally performed by the hose manufacturer, and not necessarily by the hose assembly manufacturer.

With the flexible hose assembly configured with a single loop midway along its length, and with one end connection secured, a longitudinal tensile force shall be applied to the opposite end to create a localized bend and flattening. The tensile force is increased until the cross section of the hose becomes oval and the shortest cross sectional dimension is 75 % of the original external diameter. This force shall be recorded. Upon completion a hydraulic pressure of PR shall be applied and there shall be no leakage evident.

4.2.8.2 Side impact test (1 sample) (see [A.2](#))

This test is mandatory for non-metallic lined flexible hose assemblies with copper alloys or with low impact strength material end fittings except when other side impact prevention safety measures are in place (e.g. external spring protection).

The flexible hose assembly is fixed as specified in [A.2.3.3](#). The impact energy is created with a knife edge impact tool to determine the absorbed energy for failure. Any rupture or crack is classed as a failure. This test shall be repeated at the other extremity (if different) to find the weakest side. The impact energies of both ends should be recorded.

4.2.8.3 Tensile pull test (1 sample)

This test is mandatory for non-metallic lined flexible hose assemblies except when other tensile prevention safety measures are in place (e.g. safety wire designed to take the load).

The flexible hose assembly should be capable of withstanding a longitudinal pull force of 2 670 N while in a non-pressurized state without pulling out of separating from the hose.

4.2.8.4 Fatigue cycling test under pressure (cyclic bending test)

This test shall be performed with metallic lined hoses at low pressure (e.g. 10 bar).

In addition, this test is mandatory, and performed at the relevant bending radius, for all type of flexible hose assembly at PR where the hose is subjected in service to cyclic bending under pressure.

For the procedure refer to U-bend cyclic test given in ISO 10380.

4.2.8.5 Torsion test (see [A.3](#))

In principle all risk of torsion of all types of flexible hose assemblies should be avoided.

This test is mandatory for non-metallic lined flexible hose assemblies except when used with other torsion prevention safety measures e.g. swivel joints.

Flexible hose assemblies can be subjected to torsion during use, causing the hose liner potentially to be damaged (e.g. connection and disconnection to cylinders, mis-handling of equipment while flexible hose assembly is connected).

Upon completion of torsion test, the flexible hose assembly should be removed from the test rig. Then perform:

- a) a visual inspection of the test piece and end connections for surface damage;
- b) a pneumatic test to PR to detect leakage (no more than 6 cm³/h);

c) a hydrostatic burst test as specified in [4.2](#).

4.2.8.6 Permeability test

This test may be used for applications such as high pressure hydrogen and helium in non-metallic lined hoses.

In this case, it is recommended to follow a procedure similar to the one given in ISO 11119-3.

5 Marking

The flexible hose assemblies complying with this International Standard shall be marked with the following as a minimum:

- “ISO 16964” and “A” or “B” as a reference to the appropriate category (see [4.2.3.2](#));
- “PR” followed by the value of PR and the unit (e.g. PR 250 bar);
- year and month of manufacture (production test date);
- batch number;
- manufacturer part number;
- manufacturer identification;
- mark for hydrogen compatibility “H” (if applicable, see [4.2.6](#));
- mark for acetylene service “C₂H₂” (if applicable, see [4.2.5](#)).

Annex A (normative)

Examples of kink test, side impact test and torsion test

A.1 Kink test

A.1.1 Apparatus

A typical set up of test apparatus is shown in [Figure A.2](#) and shall consist of:

- a) A test rig base incorporating a fixed and moveable skid. Each skid shall have a pipe clamp or equivalent end connection to suit the flexible hose assembly to be tested fitted to it.
- b) An actuator (e.g. hydraulic) able to apply a longitudinal load via a moveable skid with the flexible hose assembly under test installed.
- c) A means (e.g. mechanical or digital counter) able to record the load, the pulling force and the number of test cycles completed.

A.1.2 Test pieces

The kink test shall be carried out mid length of the flexible hose assembly under test (see [Figure A.2](#) and [Figure A.3](#)).

A typical test piece is shown in [Figure A.1](#).

A.1.3 Test

A.1.3.1 The test shall be conducted under ambient test area conditions.

WARNING — Kink test is potentially dangerous as test samples could fracture or break causing debris. For this reason, tests are performed in a suitable location with operators given adequate protection, (e.g. personal protective equipment and screen guards).

A.1.3.2 The flexible hose assembly shall not be pressurized during the kink test.

A.1.3.3 Secure one end of the flexible hose assembly under test to the fixed part of the test fixture and a loop formed in the centre of the test piece (see [Figure A.2](#)). The free end of the flexible hose assembly shall be attached to the moving part of the test fixture. The flexible hose assembly shall be supported between side panels to ensure a localized bend strain is achieved and the loop remains approximately vertical during flexing.

A.1.3.4 A longitudinal load shall be applied to the flexible hose assembly under test and the load shall be increased until the cross section of the hose has become oval and the shortest cross sectional dimension is 75 % of the original external diameter.

A.1.3.5 The corresponding load shall be recorded and the flexible hose assembly shall be subjected to a hydraulic pressure test at PR and there shall be no evidence of leakage. The flexible hose assembly should then be subjected to a burst test (see [4.2.2](#)).

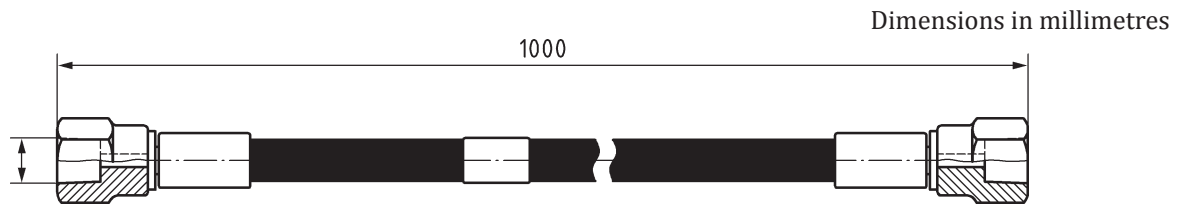
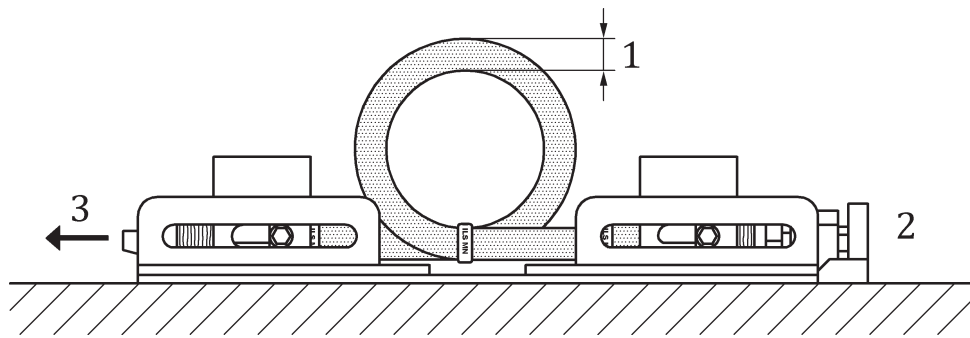

Figure A.1 — Test piece sample



Key

- 1 diameter of the flexible
- 2 fixed point
- 3 a means to apply the load

Figure A.2 — Test apparatus and set up (or equivalent)

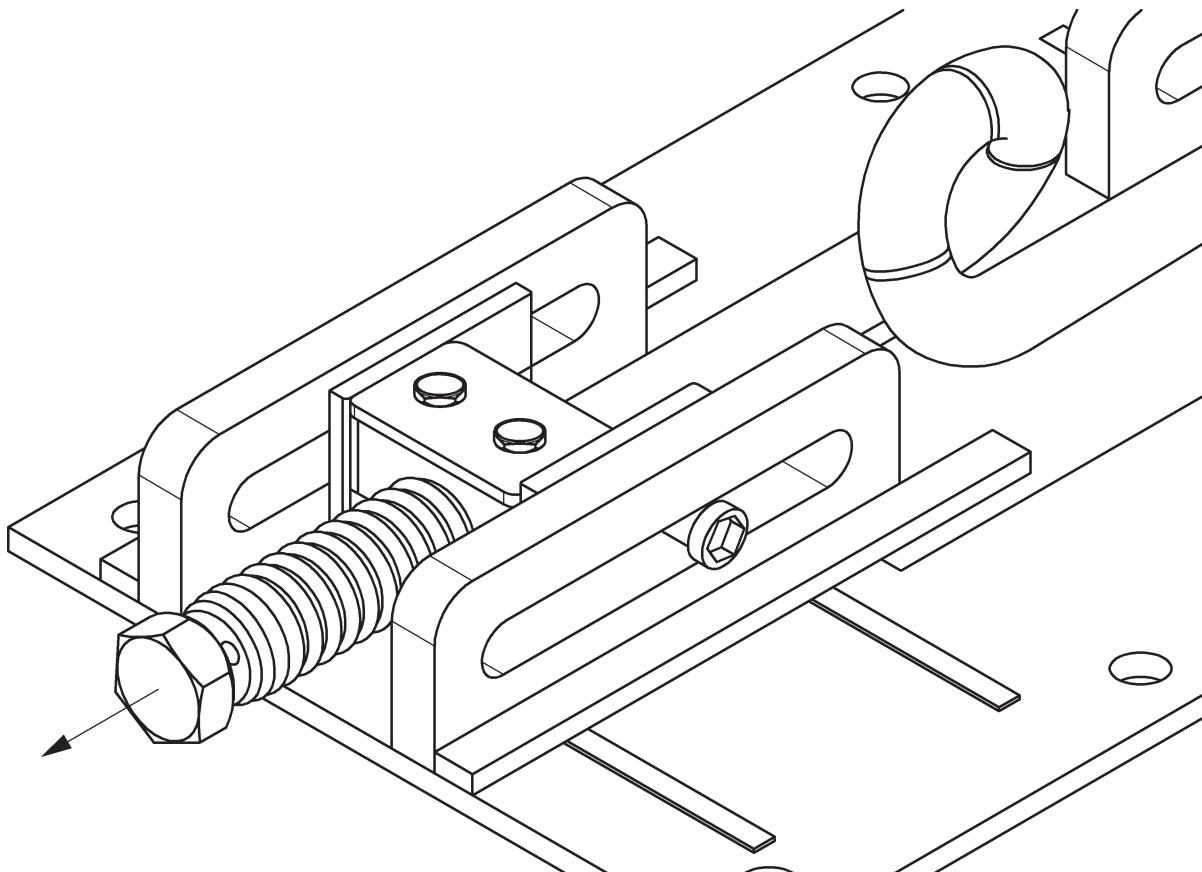

Figure A.3 — Test apparatus

A.2 Side impact test

A.2.1 Apparatus

A typical set up of test apparatus is shown in [Figure A.4](#) and shall consist of:

- a) An impact tester (e.g. a Charpy impact tester or equivalent) meeting the requirements of ISO 148-1 and incorporating gauge or digital readout to record the impact results. The impact tester used shall be capable of producing a force of 15 J.
- b) A V-notch or U-notch impactor (or equivalent).

A.2.2 Test pieces

The side impact test shall be performed on each of the flexible hose assembly end connections. Each end connection shall be tested one after the other.

A typical test piece is shown in [Figure A.1](#).

A.2.3 Test

A.2.3.1 The test shall be conducted under ambient test area conditions.

WARNING — Impact testing is potentially dangerous as test samples could fracture or break causing debris. For this reason, the test is performed in suitable location with operators using appropriate personal protective equipment (PPE) and screen guards.

A.2.3.2 The flexible hose assembly shall not be pressurized during the side impact test.

A.2.3.3 Secure one end connection of flexible hose assembly to be tested in the test apparatus as shown in [Figure A.4](#) by securely clamping the ferrule. The impact point of the impactor shall be directly on the side of the end connection on the centre line of the hose. It shall not be on the ferrule where the flexible hose assembly is additionally reinforced (see [Figure A.5](#)). Apply an impact load of 15 J to the end connection of the flexible hose assembly under test.

A.2.3.4 The flexible hose assembly end connection shall not show any signs of fracture, or damage after the test impact of 15 J has been applied.

A.2.3.5 Once the test has been completed successfully on one end connection of the flexible hose assembly, it shall be removed from the test apparatus and rotated to allow the opposite end connection to be tested.

A.2.3.6 Repeat the test as described in [A.2.3.1](#) to [A.2.3.4](#).

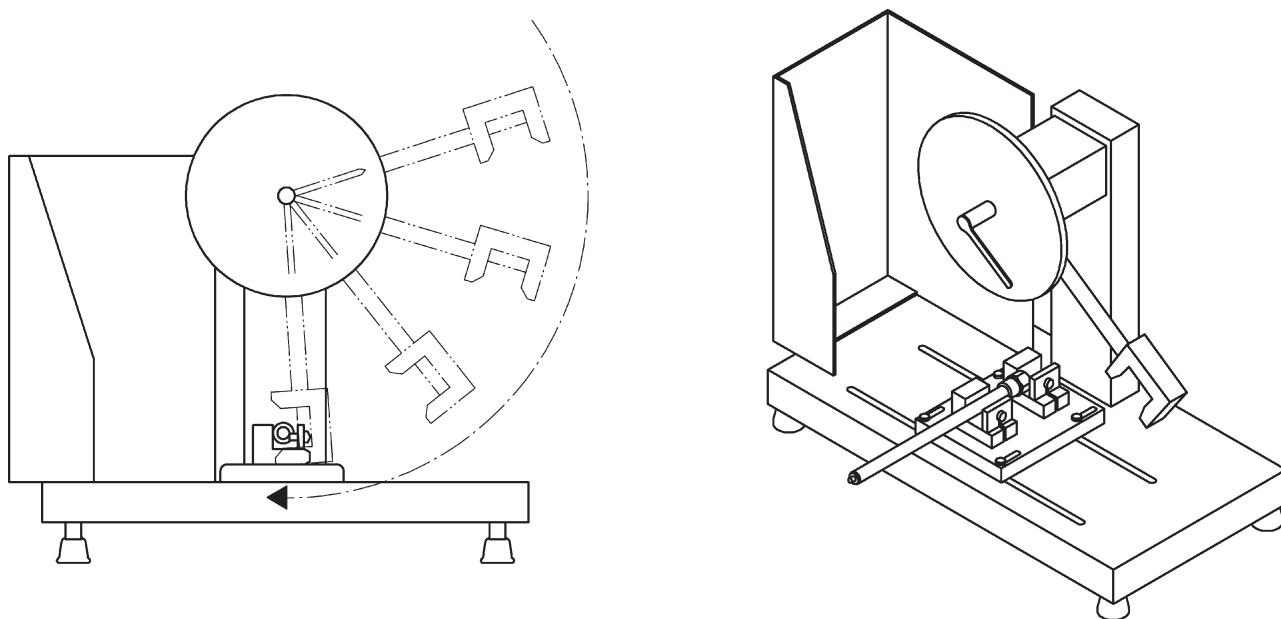

Figure A.4 — Test apparatus and set up

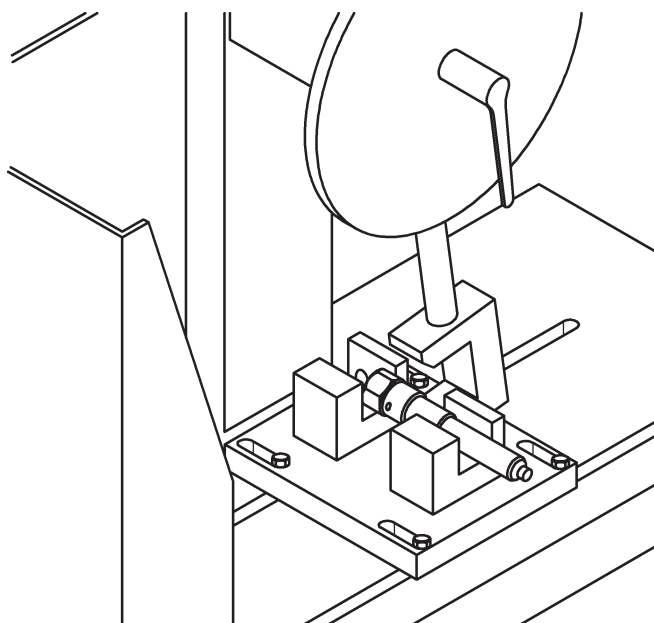

Figure A.5 — Impact point on flexible hose assembly

A.3 Torsion test

A.3.1 Apparatus

A typical set up of test apparatus is shown in [Figure A.6](#) and shall consist of:

- A test rig base incorporating a fixed part and a movable part. The movable part rotates around the long axis of the flexible hose assembly under test. Both parts shall have pipe clamps or equivalent end connections to suit the flexible hose assembly to be tested.
- An actuator (e.g. hydraulic) capable of turning the rotatable part through $\pm 90^\circ$ from the vertical axis.

c) A means (e.g. a mechanical or digital counter) of recording the number of completed test cycles.

See also [Figure A.7](#).

A.3.2 Test pieces

The torsion test shall be carried out on one end connection of the flexible hose assembly under test. Only one end connection is tested per flexible hose assembly.

A typical test piece is shown in [Figure A.1](#).

A.3.3 Test

A.3.3.1 The test shall be conducted under ambient test area conditions.

WARNING — Torsion testing is potentially dangerous as test samples could fracture and break causing debris. For this reason, the test is performed in suitable location with operators using appropriate personal protective equipment (PPE) and screen guards.

A.3.3.2 The flexible hose assembly shall not be pressurized during the test.

A.3.3.3 Secure one end of the flexible hose assembly under test to the fixed part of the test apparatus and the other to the rotatable part (see [Figure A.5](#)).

A.3.3.4 Starting from a local vertical position, rotate the movable end of the test apparatus through 90° angle in one direction, then through 180° angle in the other direction and then 90° angle to get back to the starting point. This is one test cycle.

A.3.3.5 Rotate the flexible hose assembly through 10 000 cycles at a rate of 30 cycles ± 2 cycles per minute.

A.3.3.6 Once the 10 000 test cycles have been completed, remove the hose from the test apparatus and allow the flexible hose assembly to remain stationary (in its un-twisted starting position) for 60 min.

A.3.3.7 After 60 min, the flexible hose assembly shall be subjected to a visual inspection of the test piece, and a pneumatic test at PR to detect leakage. The flexible hose assembly should then be subjected to a burst test (see [4.2.2](#)).

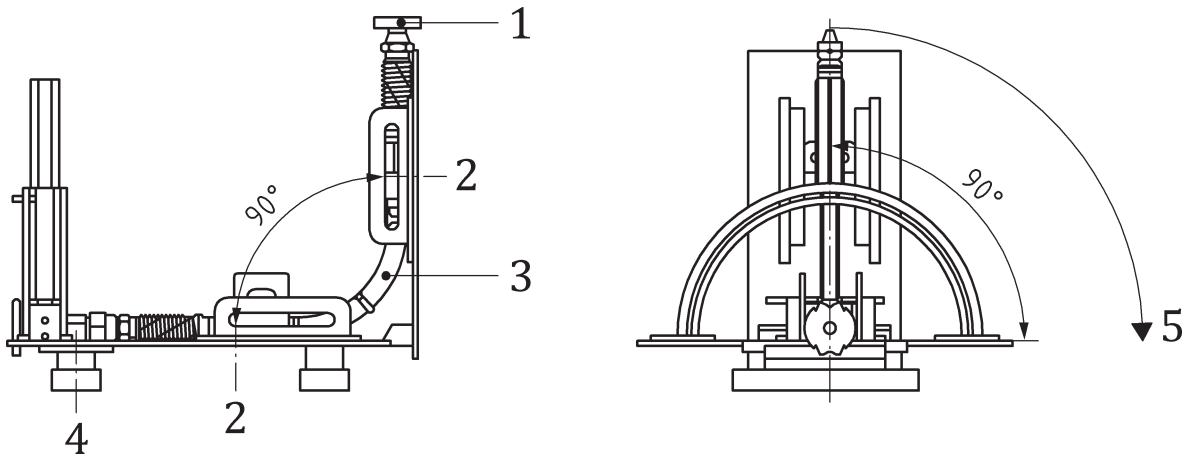

Key

- 1 a means to apply torsion
- 2 90° angle
- 3 flexible hose assembly
- 4 fixed point
- 5 90° angle

Figure A.6 — Test apparatus and set up (or equivalent)

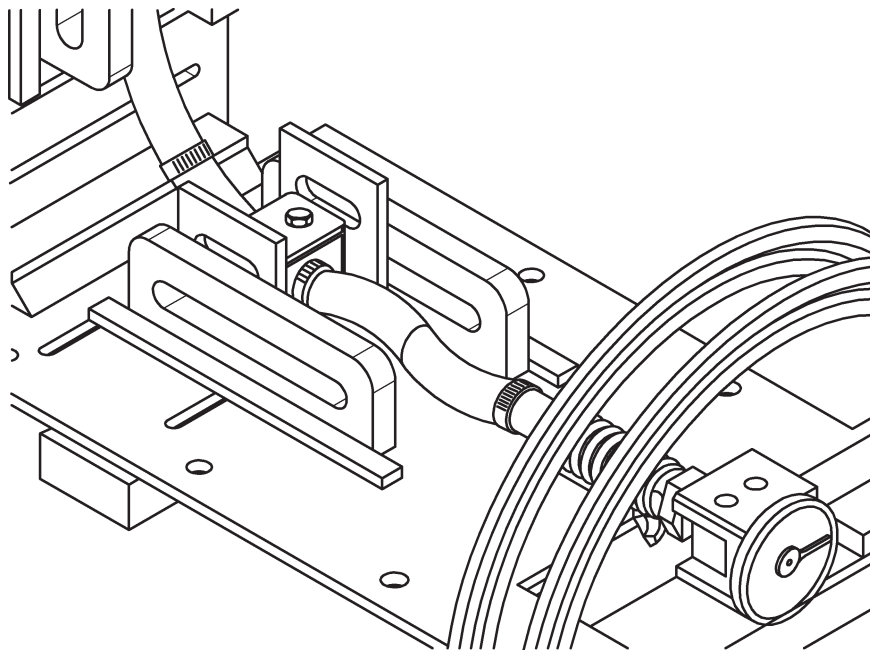

Figure A.7 — Sinusoidal movement of $\pm 90^\circ$ about the rotating x-axis

Bibliography

- [1] ISO 5359, *Anaesthetic and respiratory equipment — Low-pressure hose assemblies for use with medical gases*
- [2] ISO 3821, *Gas welding equipment — Rubber hoses for welding, cutting and allied processes*
- [3] ISO 12170, *Gas welding equipment — Thermoplastic hoses for welding and allied processes*
- [4] ISO 21012, *Cryogenic vessels — Hoses*
- [5] ISO 11114-1, *Gas cylinders — Compatibility of cylinder and valve materials with gas contents — Part 1: Metallic materials*
- [6] ISO 11114-2, *Gas cylinders — Compatibility of cylinder and valve materials with gas contents — Part 2: Non-metallic materials*
- [7] ISO 11119-3, *Gas cylinders — Refillable composite gas cylinders and tubes — Design, construction and testing — Part 3: Fully wrapped fibre reinforced composite gas cylinders and tubes up to 450L with non-load-sharing metallic or non-metallic liners*

