

Building construction — Determination of the staining of porous substrates by sealants used in joints —

Part 2: Test without compression

ICS 91.100.50

National foreword

This British Standard is the UK implementation of ISO 16938-2:2008.

The UK participation in its preparation was entrusted to Technical Committee B/547, Sealants for building and construction.

A list of organizations represented on this committee can be obtained on request to its secretary.

This publication does not purport to include all the necessary provisions of a contract. Users are responsible for its correct application.

Compliance with a British Standard cannot confer immunity from legal obligations.

This British Standard was published under the authority of the Standards Policy and Strategy Committee on 30 April 2008

© BSI 2008

ISBN 978 0 580 53261 0

Amendments/corrigenda issued since publication

Date	Comments

INTERNATIONAL
STANDARD

ISO
16938-2

First edition
2008-03-01

**Building construction — Determination of
the staining of porous substrates by
sealants used in joints —**

Part 2:
Test without compression

*Construction immobilière — Détermination du tachage des supports
poreux par les mastics utilisés dans les joints —*

Partie 2: Essai sans compression



Reference number
ISO 16938-2:2008(E)

Foreword

ISO (the International Organization for Standardization) is a worldwide federation of national standards bodies (ISO member bodies). The work of preparing International Standards is normally carried out through ISO technical committees. Each member body interested in a subject for which a technical committee has been established has the right to be represented on that committee. International organizations, governmental and non-governmental, in liaison with ISO, also take part in the work. ISO collaborates closely with the International Electrotechnical Commission (IEC) on all matters of electrotechnical standardization.

International Standards are drafted in accordance with the rules given in the ISO/IEC Directives, Part 2.

The main task of technical committees is to prepare International Standards. Draft International Standards adopted by the technical committees are circulated to the member bodies for voting. Publication as an International Standard requires approval by at least 75 % of the member bodies casting a vote.

Attention is drawn to the possibility that some of the elements of this document may be the subject of patent rights. ISO shall not be held responsible for identifying any or all such patent rights.

ISO 16938-2 was prepared by Technical Committee ISO/TC 59, *Building construction*, Subcommittee SC 8, *Jointing products*.

ISO 16938 consists of the following parts, under the general title *Building construction — Determination of the staining of porous substrates by sealants used in joints*:

- *Part 1: Test with compression*
- *Part 2: Test without compression*

Building construction — Determination of the staining of porous substrates by sealants used in joints —

Part 2: Test without compression

1 Scope

This part of ISO 16938 specifies a method for determining the staining of porous substrates (e.g. marble, limestone, sandstone, or granite) by sealants used in building construction. The method evaluates the likelihood of a sealant causing an early stain on a porous substrate due to exudation of materials from the sealant. The outcome of the test is specific to the tested sealant and tested substrate and cannot be extrapolated to other sealant formulations or other porous substrates. During this accelerated test, if the sealant does not stain or discolour the substrates, it does not mean that the tested sealant will not stain or discolour the tested porous substrate over a longer time period.

2 Normative references

The following referenced documents are indispensable for the application of this document. For dated references, only the edition cited applies. For undated references, the latest edition of the referenced document (including any amendments) applies.

ISO 4892-1, *Plastics — Methods of exposure to laboratory light sources — Part 1: General guidance*

ISO 4892-2:2006, *Plastics — Methods of exposure to laboratory light sources — Part 2: Xenon-arc lamps*

ISO 4892-3, *Plastics — Methods of exposure to laboratory light sources — Part 3: Fluorescent UV lamps*

ISO 6927, *Building construction — Jointing products — Sealants — Vocabulary*

ISO 11431:2002, *Building construction — Jointing products — Determination of adhesion/cohesion properties of sealants after exposure to heat, water and artificial light through glass*

3 Terms and definitions

For the purposes of this document, the terms and definitions given in ISO 6927 apply.

4 Principle

This method measures the visible staining attributed to joint sealants on porous substrates that is a result of the conditioning specified.

A sealant is applied and cured between two pieces of porous substrate. The test specimens are subjected to heat aging and/or cold aging and/or aging in actinic radiation accelerated weathering equipment. After aging, the test specimens are evaluated and visible staining is recorded on the exterior surface and in the interior of the substrate after visual inspection of changes in surface appearance and measurements of maximum and minimum stain width and stain penetration.

5 Apparatus

5.1 Substrate materials, for the preparation of each test specimen; two substrate pieces of the same material are required with dimensions as shown in Figure 1.

5.2 Spacers, for the preparation of the test specimens, of cross-section 12 mm × 12 mm, with non-adherent surface (see Figure 1).

NOTE If the spacers are made of a material to which the sealant adheres, their surfaces should be made non-adherent, e.g. by a thin wax coating.

5.3 Non-adherent substrate, for the preparation of test specimens, e.g. polyethylene (PE) film, preferably on the advice of the sealant manufacturer.

5.4 Masking tape, suitable for covering the tested surface of the substrates (see Figure 1) to prevent sealant contamination during specimen preparation.

5.5 Ventilated convection-type oven, capable of being maintained at $(70 \pm 2) ^\circ\text{C}$.

5.6 Refrigerated enclosure, capable of being maintained at $(-20 \pm 2) ^\circ\text{C}$.

5.7 Actinic radiation accelerated aging apparatus.

Fluorescent ultraviolet radiation/condensation test apparatus or xenon light test apparatus shall be employed as actinic radiation accelerated aging apparatus.

NOTE Test results can differ between the exposure to fluorescent ultraviolet radiation/condensation and xenon light because of differences in the spectral power distribution of the radiation source and differences in the exposure conditions a) to d). See 8.4.

5.7.1 Fluorescent ultraviolet radiation/condensation test apparatus, fitted with fluorescent UVA-340 lamps having their peak emission at 343 nm, capable of exposing the test specimens to radiation under controlled conditions of temperature and moisture or water, complying with the requirements of ISO 4892-3. Standard practices for operating such accelerated weathering chambers are described in ISO 4892-1. The target value for irradiance at 340 nm shall be $(0,77 \pm 0,02) \text{ Wm}^2$ at $60 ^\circ\text{C}$.

5.7.2 Xenon light test apparatus, fitted with xenon light source with daylight filter, capable of exposing the test specimens to radiation under controlled conditions of temperature and water, complying with the requirements of ISO 4892-2:2006, Table 3, Method A (cycle 1 or 2). Irradiance at the surface of the test specimens between the wavelength of 290 nm and 800 nm shall be $(550 \pm 75) \text{ W/m}^2$. Irradiance below 300 nm shall not exceed 1 W/m^2 .

5.8 Black standard thermometer, complying with the requirements of ISO 4892-1. All temperatures reported in this part of ISO 16938 for the UV exposure apparatus are measured with the black standard thermometer. Black panel thermometer may also be used. Under given operating conditions, they tend to indicate lower temperatures than the black standard thermometer. The temperature difference between the measurements will depend on the test temperature, but can be up to $10 ^\circ\text{C}$.

5.9 Measuring device, scaled in half millimetres.

Dimensions in millimetres

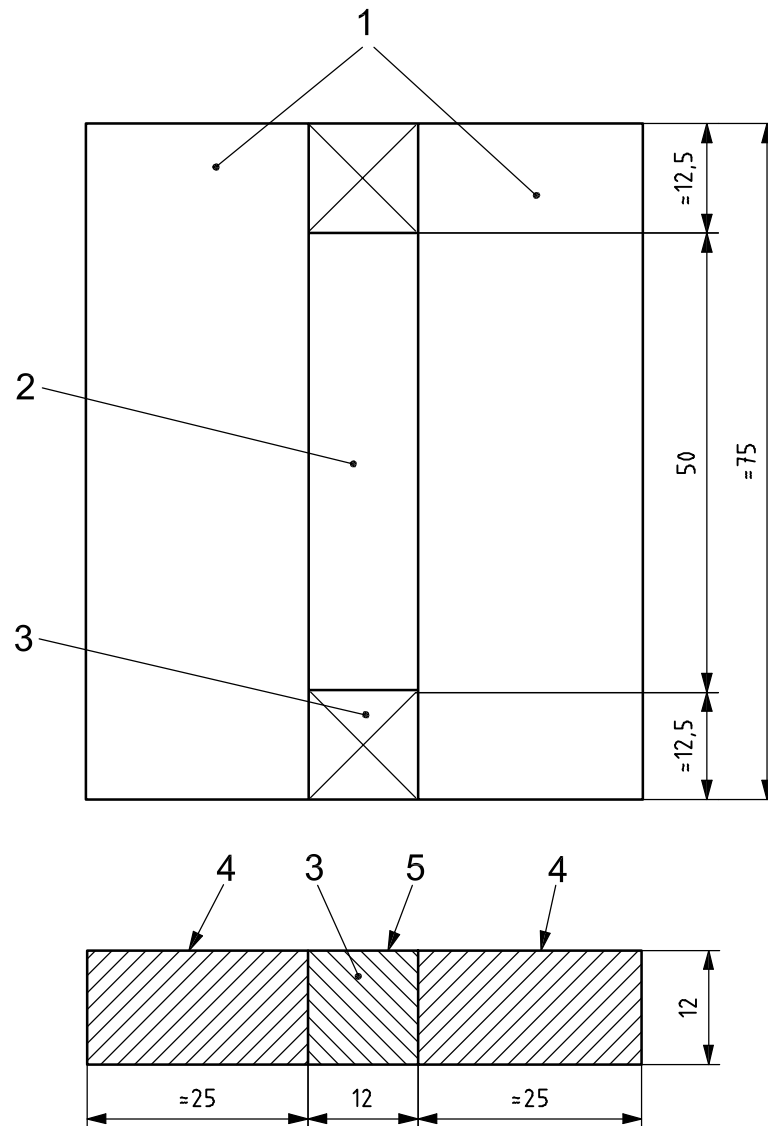
**Key**

- 1 substrate
- 2 sealant
- 3 spacer
- 4 tested surface
- 5 tooled surface

Figure 1 — Test specimen assembly**6 Preparation of test specimens**

Four test specimens for each sealant and each aging method shall be prepared.

For each test specimen, two substrate materials (5.1) and two spacers (5.2) shall be assembled (see Figure 1) and set up on the non-adherent substrate (5.3).

The instructions of the sealant manufacturer concerning, for instance, whether a primer is to be used, and the mixing procedure for multi-component sealants, shall be followed.

The following procedure shall be used for specimen preparation:

- a) the sealant and the substrate materials (5.1) shall be brought to (23 ± 2) °C;
- b) the tested surface of both substrate materials shall be placed in the same plane as the tooled surface of the sealant (see Figure 1).
- c) masking tape (5.4) shall be applied on the tested surfaces of the substrate materials to prevent sealant contamination during specimen preparation;
- d) the hollow volume formed by the substrate materials and spacers (5.2) shall be filled with the sealant (avoiding the formation of air bubbles);
- e) the sealant shall be pressed to the inner surfaces of the substrate materials;
- f) the sealant surface shall be trimmed so that it is flush with the masking tapes on the faces of the substrate materials and spacers;
- g) immediately following application and tooling of the sealant, the masking tape shall be removed;
- h) the test specimens shall be set on edge on one of the substrate materials and the non-adherent substrate removed as soon as possible; the specimens shall remain in this position with the spacers in place for another 48 h to allow curing or optimum drying of the sealant.

7 Conditioning

The test specimens shall be conditioned for 28 d at (23 ± 2) °C and (50 ± 5) % relative humidity.

8 Aging procedures

8.1 General

One or more of the following aging procedures (8.2, 8.3, 8.4) shall be carried out as agreed between the concerned parties.

8.2 Heat aging

Four of the specimens shall be placed in an oven (5.5) at (70 ± 2) °C. Remove two specimens after 14 d and the other two specimens after 28 d.

8.3 Cold aging

Four of the specimens shall be placed in a refrigerated enclosure (5.6) at (-20 ± 2) °C. Remove two specimens after 14 d and the other two specimens after 28 d.

8.4 Actinic radiation aging

As agreed between the concerned parties, the test specimens shall be exposed to actinic radiation according to one of the following aging procedures:

- UV fluorescent radiation condensation apparatus (5.7.1) with wet exposure condition [see a)];
- xenon lamp test apparatus (5.7.2) with wet exposure condition [see b)];
- UV fluorescent radiation condensation apparatus (5.7.1) with dry exposure condition [see c)];
- xenon lamp test apparatus (5.7.2) with dry exposure condition [see d)].

Four of the specimens shall be placed in the actinic radiation exposure apparatus, with the tested surface perpendicularly facing the radiation source. Two specimens shall be removed after 14 d and the other two specimens after 28 d.

Wet exposure.

- a) In the UV fluorescent radiation/condensation test apparatus the sealant surface shall be held 50 mm from the radiation source. The cycle of the UV fluorescent radiation/condensation test apparatus shall be set to 8 h UV radiation at $(60 \pm 2) ^\circ\text{C}$, and 4 h condensation at $(50 \pm 2) ^\circ\text{C}$.
- b) In the xenon-lamp test apparatus, the specimens shall be exposed to cycles of dry periods with radiation followed by wet periods (water spray or immersion) as defined in ISO 11431:2002, 8.2.2 (automatic cycling) or 8.2.3 (manual cycling).

Dry exposure.

- c) In the UV fluorescent radiation/condensation test apparatus, the sealant surface shall be held 50 mm from the radiation source. The UV fluorescent radiation/condensation test apparatus shall be set to UV radiation at $(60 \pm 2) ^\circ\text{C}$.
- d) In the xenon-lamp test apparatus, the specimens shall be exposed dry to radiation for a period of 500 h at a temperature of $(65 \pm 2) ^\circ\text{C}$ as measured on the black standard thermometer (5.8).

9 Detection of staining

9.1 General

After aging, the test specimens shall be conditioned at $(23 \pm 2) ^\circ\text{C}$ and $(50 \pm 5) \%$ relative humidity for one day.

9.2 Detection at the surface of the substrate

The substrates shall be examined to determine if the sealant caused the tested surface to change in appearance in any way. If so, the maximum and minimum dimensions of the stain width on the tested surface of the substrate shall be measured to the nearest 0,5 mm, using the measurement device (5.9) (see Figure 2), and recorded.

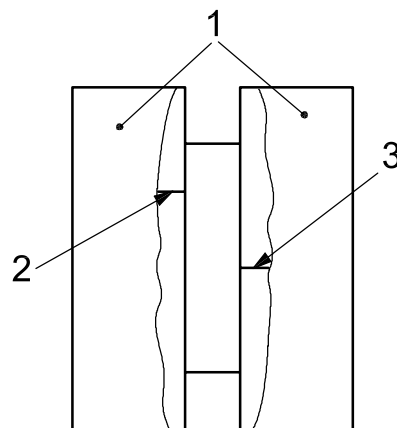

Key

- 1 substrate material
- 2 minimum stain width
- 3 maximum stain width

Figure 2 — Determination of minimum and maximum stain width

9.3 Detection in the depth of the substrate

The substrates shall be broken perpendicular to the joint within the area of maximum stain width. If no staining can be observed on the tested substrate surface, the substrates shall be broken in half. The bulk of the substrate shall be examined to determine if the sealant has caused any discoloration of the substrate itself. The maximum and minimum of the stain penetration into the bulk substrate (see Figure 3) at the centre of the sealant joint (6 mm depth) shall be recorded to the nearest 0,5 mm, using the measurement device (5.9).

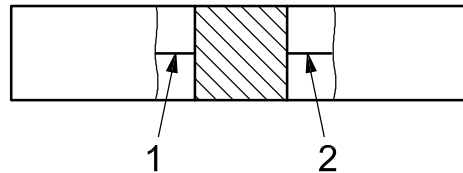

- Key**
- 1 minimum stain penetration
 - 2 maximum stain penetration

Figure 3 — Determination of minimum and maximum stain penetration

9.4 Expression of results

The minimum and maximum measurements of stain width and penetration of each of the two specimens shall be determined for each of the test conditions (see Figure 4 for an example worksheet).

Exposure	Specimen	Substrate	Duration			
			14 days		28 days	
			Minimum stain width	Maximum stain width	Minimum stain width	Maximum stain width
70 °C	1	A	2	8	4	15
		B	3	5	8	12
	2	A	4	6	9	10
		B	2	4	5	9
	Report		2	8	4	15
-20 °C	1	A				
		B				
	2	A				
		B				
	Report					
Xenon (wet exposure)	1	A				
		B				
	2	A				
		B				
	Report					

Figure 4 — Example worksheet for determination of reportable maximum and minimum stain width and penetration

For some sealant formulations, the ease and reliability of the detection of staining may be improved by inspecting the test specimen in a dark room under illumination with a short-wave length UV lamp.

Sometimes the detection of hydrophobic staining may be improved by wetting the substrates with water. Some sealants may stain the substrates completely, resulting in a uniform discolouration of the substrates and making the detection of the stain difficult. In this situation, it may be helpful to compare the substrate surface to an unexposed control.

10 Test report

The test report shall include the following information:

- a) name of test laboratory, number and date of test report;
- b) reference to this part of ISO 16938, i.e. ISO 16938-2:2008;
- c) name, type (chemical family) and colour of sealant;
- d) batch of sealant from which the test specimens were produced, if possible;
- e) substrate material, substrate source (place of origin) and tested surface finish;
- f) name, type and batch of primer from which the test specimens were produced, if applicable;
- g) details of test procedure, as agreed between the concerned parties, namely:
 - 1) the specific aging procedures employed, i.e. heat aging, and/or cold aging, and/or actinic radiation aging (8.2 and/or 8.3 and/or 8.4);
 - 2) the type of actinic radiation aging procedure employed [(i), ii), iii), or iv]):
 - i) UV fluorescent radiation condensation apparatus (5.7.1) with wet exposure condition;
 - ii) xenon lamp test apparatus (5.7.2) with wet exposure condition;
 - iii) UV fluorescent radiation condensation apparatus (5.7.1) with dry exposure condition;
 - iv) xenon lamp test apparatus (5.7.2) with dry exposure condition;
 - 3) the type of water exposure used in the xenon light apparatus (spray or immersion);
 - 4) the type of cycling method used in the xenon light apparatus (manual or automatic);
- h) minimum and maximum measurements of stain width and penetration for each of the two specimens and each of the test conditions;
- i) any deviations from the specified test conditions.

BSI — British Standards Institution

BSI is the independent national body responsible for preparing British Standards. It presents the UK view on standards in Europe and at the international level. It is incorporated by Royal Charter.

Revisions

British Standards are updated by amendment or revision. Users of British Standards should make sure that they possess the latest amendments or editions.

It is the constant aim of BSI to improve the quality of our products and services. We would be grateful if anyone finding an inaccuracy or ambiguity while using this British Standard would inform the Secretary of the technical committee responsible, the identity of which can be found on the inside front cover.
Tel: +44 (0)20 8996 9000. Fax: +44 (0)20 8996 7400.

BSI offers members an individual updating service called PLUS which ensures that subscribers automatically receive the latest editions of standards.

Buying standards

Orders for all BSI, international and foreign standards publications should be addressed to Customer Services. Tel: +44 (0)20 8996 9001.
Fax: +44 (0)20 8996 7001. Email: orders@bsi-global.com. Standards are also available from the BSI website at <http://www.bsi-global.com>.

In response to orders for international standards, it is BSI policy to supply the BSI implementation of those that have been published as British Standards, unless otherwise requested.

Information on standards

BSI provides a wide range of information on national, European and international standards through its Library and its Technical Help to Exporters Service. Various BSI electronic information services are also available which give details on all its products and services. Contact the Information Centre.
Tel: +44 (0)20 8996 7111. Fax: +44 (0)20 8996 7048. Email: info@bsi-global.com.

Subscribing members of BSI are kept up to date with standards developments and receive substantial discounts on the purchase price of standards. For details of these and other benefits contact Membership Administration.
Tel: +44 (0)20 8996 7002. Fax: +44 (0)20 8996 7001.
Email: membership@bsi-global.com.

Information regarding online access to British Standards via British Standards Online can be found at <http://www.bsi-global.com/bsonline>.

Further information about BSI is available on the BSI website at <http://www.bsi-global.com>.

Copyright

Copyright subsists in all BSI publications. BSI also holds the copyright, in the UK, of the publications of the international standardization bodies. Except as permitted under the Copyright, Designs and Patents Act 1988 no extract may be reproduced, stored in a retrieval system or transmitted in any form or by any means – electronic, photocopying, recording or otherwise – without prior written permission from BSI.

This does not preclude the free use, in the course of implementing the standard, of necessary details such as symbols, and size, type or grade designations. If these details are to be used for any other purpose than implementation then the prior written permission of BSI must be obtained.

Details and advice can be obtained from the Copyright & Licensing Manager.
Tel: +44 (0)20 8996 7070. Fax: +44 (0)20 8996 7553.
Email: copyright@bsi-global.com.