

BS ISO 16840-10:2014



BSI Standards Publication

Wheelchairs — Resistance to ignition of non-integrated seat and back support cushions

Part 10: Requirements and test methods

bsi.

...making excellence a habit.™

National foreword

This British Standard is the UK implementation of ISO 16840-10:2014.

The UK participation in its preparation was entrusted to Technical Committee CH/173/1, Wheelchairs.

A list of organizations represented on this committee can be obtained on request to its secretary.

This publication does not purport to include all the necessary provisions of a contract. Users are responsible for its correct application.

© The British Standards Institution 2014. Published by BSI Standards Limited 2014

ISBN 978 0 580 82454 8

ICS 11.180.10

Compliance with a British Standard cannot confer immunity from legal obligations.

This British Standard was published under the authority of the Standards Policy and Strategy Committee on 31 December 2014.

Amendments issued since publication

Date	Text affected
------	---------------

**Wheelchairs — Resistance to ignition
of non-integrated seat and back
support cushions —**

**Part 10:
Requirements and test methods**

*Fauteuils roulants — Résistance à l'inflammation des coussins de
sièges et de dossiers non intégrés —*

Partie 10: Exigences et méthodes d'essai





COPYRIGHT PROTECTED DOCUMENT

© ISO 2014

All rights reserved. Unless otherwise specified, no part of this publication may be reproduced or utilized otherwise in any form or by any means, electronic or mechanical, including photocopying, or posting on the internet or an intranet, without prior written permission. Permission can be requested from either ISO at the address below or ISO's member body in the country of the requester.

ISO copyright office
Case postale 56 • CH-1211 Geneva 20
Tel. + 41 22 749 01 11
Fax + 41 22 749 09 47
E-mail copyright@iso.org
Web www.iso.org

Published in Switzerland

Contents

Page

Foreword	iv
Introduction	v
1 Scope	1
2 Normative references	1
3 Terms and definitions	2
4 Principle	2
5 Health and safety of test personnel	2
5.1 General.....	2
5.2 Enclosure.....	2
5.3 Extinguishers.....	2
6 Apparatus	3
6.1 Test rig.....	3
6.2 Test enclosure.....	3
6.3 Timer.....	3
6.4 Heat source.....	3
6.5 Conditioning environment.....	4
6.6 Test environment.....	5
6.7 Test sample.....	5
7 Test procedure	5
7.1 Preparation.....	5
7.2 Horizontal test.....	5
7.3 Vertical test.....	6
8 Requirements	6
9 Test report	6
10 Disclosure of results	6
Annex A (informative) Design of a heat source as a surrogate cigarette device	8
Annex B (normative) Conditioning of outer cover materials by washing and drying procedures	11
Bibliography	13

Foreword

ISO (the International Organization for Standardization) is a worldwide federation of national standards bodies (ISO member bodies). The work of preparing International Standards is normally carried out through ISO technical committees. Each member body interested in a subject for which a technical committee has been established has the right to be represented on that committee. International organizations, governmental and non-governmental, in liaison with ISO, also take part in the work. ISO collaborates closely with the International Electrotechnical Commission (IEC) on all matters of electrotechnical standardization.

The procedures used to develop this document and those intended for its further maintenance are described in the ISO/IEC Directives, Part 1. In particular the different approval criteria needed for the different types of ISO documents should be noted. This document was drafted in accordance with the editorial rules of the ISO/IEC Directives, Part 2 (see www.iso.org/directives).

Attention is drawn to the possibility that some of the elements of this document can be the subject of patent rights. ISO shall not be held responsible for identifying any or all such patent rights. Details of any patent rights identified during the development of the document will be in the Introduction and/or on the ISO list of patent declarations received (see www.iso.org/patents).

Any trade name used in this document is information given for the convenience of users and does not constitute an endorsement.

For an explanation on the meaning of ISO specific terms and expressions related to conformity assessment, as well as information about ISO's adherence to the WTO principles in the Technical Barriers to Trade (TBT), see the following URL: [Foreword — Supplementary information](#).

The committee responsible for this document is ISO/TC 173, *Assistive products for persons with disability*, Subcommittee SC 1, *Wheelchairs*.

ISO 16840 consists of the following parts, under the general title *Wheelchairs — Resistance to ignition of non-integrated seat and back support cushions*:

- *Part 1: Vocabulary, reference axis convention and measures for body segments, posture and postural support surfaces*
- *Part 2: Determination of physical and mechanical characteristics of devices intended to manage tissue integrity — Seat cushions*
- *Part 3: Determination of static, impact and repetitive load strengths for postural support devices*
- *Part 4: Seating systems for use in motor vehicles*
- *Part 6: Simulated use and determination of the changes in properties — Seat cushions*
- *Part 10: Resistance to ignition of non-integrated seat and back support cushions — Requirements and test methods*
- *Part 11: Determination of perspiration dissipation characteristics of seat cushions intended to manage tissue integrity [Technical Specification]*

The following parts are under preparation:

- *Part 9: Clinical interface pressure mapping guidelines for seating [Technical Report]*
- *Part 12: Apparatus and method for cushion envelopment testing*

Introduction

The ignition and subsequent burning of wheelchairs is very rare, but can occur as a result of

- being close to a burning object such as a fire beside the wheelchair,
- overheating of any electrical or electronic device on the wheelchair, and
- contact from sparks or flames (such as welding sparks, cigarettes, or matches).

Wheelchair occupants are at particular risk of injury or death from these fires and resulting fumes because they may not have the ability to move away from the wheelchair.

Wheelchairs can be considered to be comprised of the following components:

- a) structural components such as the frame, wheels, etc. which are essential to the mechanical integrity of the wheelchair;
- b) postural support devices, such as sling seats, sling back supports, arm supports, foot supports, etc., which are attached to the wheelchair and are primarily intended to give postural support to the wheelchair occupant (these can also be intended to aid in pressure redistribution);
- c) devices to manage tissue integrity, such as seat and back support cushions which are intended to have primarily a clinical function to minimize the risks of skin damage (these can also be intended to control or accommodate posture);
- d) power-related components such as motors, energy sources, controllers etc., which are required for the functioning of powered devices on wheelchairs.

Each of the above components has a different severity of risk associated with its likelihood of igniting and its resulting harm to the wheelchair occupant. ISO standards have been published or are in preparation to specify requirements and test methods for the above categories of components to help manufacturers and purchasers of wheelchairs to design and procure wheelchairs and their components which are appropriate for the risk of ignition balanced against the functional needs of the wheelchair occupant. The aim of these ISO standards is to provide appropriate alternatives to using furniture-based flammability standards, to reflect the uses and purposes of wheelchairs and their accessories.

The development of an ISO standard on the resistance to ignition of structural components [see list item a) above] has not yet commenced. The most likely sources of ignition are proximity to a heat source such as an electric radiator or domestic fire or a heat source such as a lighted match or cigarette falling onto the structure.

ISO 7176-16 is primarily concerned with the resistance to ignition of postural support device components of a wheelchair [see list item b) above]. These typically include arm supports, sling seats, sling back supports, lower leg supports, foot supports, lateral supports, head supports, etc. The most likely source of ignition is an open flame source falling onto the component's surface or into gaps between surfaces. Consequently that standard is written around resistance to a heat source equivalent to a lighted match in contact with a test sample of an assembly of the upholstered part's composite materials in both a vertical and horizontal orientation.

The power related components [see list item d) above] are the subject of ISO 7176-14 which specifies requirements to prevent overheating in electrical components that could lead to a fire.

The tissue integrity devices [see list item c) above] are the subject of this part of ISO 16840, and permit a less stringent resistance to ignition than in ISO 7176-16, based upon the priority of these components for their clinical function, which might override the need for a high resistance to ignitability.

The requirements of this part of ISO 16840 have been set at a basic minimum level and are less severe than mandatory requirements in some countries. This part of ISO 16840 has been produced to allow for the use of materials that would not meet the requirements of ISO 7176-16, but the manufacturer is required to make the case as to why ISO 7176-16 could not be employed. Good practice is also to use

materials which minimize the risk of release of toxic substances as a result of ignition. Materials chosen are to comply also with biocompatibility requirements (ISO 10993-1 and ISO 10993-10).

The day to day usage of a wheelchair may affect its materials' resistance to ignition through cyclic loading, movement of materials, washing, cleaning, etc. Manufacturers will often take this effect into account as part of their risk assessment when selecting materials for their products to minimize the effects of this normal use. However, although this part of ISO 16840 can be used on parts that have been used, etc., the test samples specify new or unused parts.

Different environments commonly encountered by some wheelchair occupants may also affect the flammability of materials. For example, home oxygen systems, delivery systems for drugs carried in an inflammable medium, etc., can turn an inert material into a flammable one. Dust and other materials accumulated within the chair have also been found to be a source of readily ignitable material. Wheelchair manufacturers and occupants should be aware of these risks, and design and use wheelchairs accordingly as covered by ISO 14971.

This part of ISO 16840 describes testing an assembly of the composite of materials as used in the wheelchair component, because the resistance to ignition of these materials individually can be quite different from those when assembled as a composite. Hence, the results of this part of ISO 16840 do not give any indication of the resistance to ignition of any of the separate individual materials of the test sample.

Wheelchairs — Resistance to ignition of non-integrated seat and back support cushions —

Part 10: Requirements and test methods

1 Scope

This part of ISO 16840 specifies requirements and test methods to assess the resistance to ignition by smouldering cigarette equivalent of non-integrated components of a wheelchair intended to protect tissue integrity.

The test measures only the resistance to ignition by smouldering cigarette equivalent of the items tested and not the ignitability of the complete wheelchair. It gives an indication, but cannot guarantee, the ignition behaviour of the assembled non-integrated devices of a complete wheelchair.

This part of ISO 16840 does not apply to resistance to ignition of structural parts of a wheelchair, nor does it cover postural support devices. This part of ISO 16840 does not cover changes in resistance to ignition as a result of regular washing or use.

This part of ISO 16840 allows for the separate testing of removable non-integrated components of a wheelchair which are normally used in the horizontal plane (e.g. a seat cushion) from those normally used in the vertical plane (e.g. a back support).

This part of ISO 16840 describes testing an assembly of the composite of materials as used in the removable non-integrated component. The results of this part of ISO 16840 do not give any indication of the resistance to ignition of any of the separate individual materials of the test sample.

NOTE 1 The intent of this part of ISO 16840 is primarily to cover removable cushions whose described purpose is that of protecting skin tissue against pressure, shear, and maceration related damage.

NOTE 2 The requirements of this part of ISO 16840 have been set at a basic minimal level and are less severe than mandatory requirements in some countries.

Where practical, it is advisable that manufacturers use materials with superior resistance to ignition. The manufacturer is required to make the case as to why ISO 7176-16 could not be employed rather than this part of ISO 16840.

NOTE 3 Requirements for the control of risks from sources of fire created by electrical and electronic components are included in ISO 7176-14

2 Normative references

The following referenced documents are indispensable for the application of this document. For dated references, only the edition cited applies. For undated references, the latest edition of the referenced document (including any amendments) applies.

ISO 14971, *Medical devices — Application of risk management to medical devices*

ISO 554, *Standard atmospheres for conditioning and/or testing — Specifications*

EN 1021-1:2006, *Furniture — Assessment of the ignitability of upholstered furniture — Part 1: Ignition source smouldering cigarette*

3 Terms and definitions

For the purposes of this document, the terms and definitions given in ISO 7176-26 and ISO 8191-1:1987 and the following apply.

3.1 flaming

undergoing combustion in the gaseous phase with the emission of light

[SOURCE: ISO 8191-1:1987, definition 3.2]

3.2 non-integrated

detachable without the use of tools

Note 1 to entry: Seat or back cushions held in place by hook and loop fastenings are also considered non-integrated.

Note 2 to entry: Other upholstered parts (such as padded seat or back canvasses) attached to the chair by hook and loop fastenings are regarded as wheelchair postural support devices as covered by ISO 7176-16.

3.3 progressive smouldering

exothermic oxidation, not accompanied by flaming, that is self-propagating i.e. independent of the ignition source

[SOURCE: ISO 8191-1:1987, definition 3.1]

Note 1 to entry: It may or may not be accompanied by incandescence.

4 Principle

Test materials used in non-integrated seat and back support devices as used in wheelchairs are assembled in either horizontal or vertical samples and subjected to a heat source which is equivalent to a smouldering cigarette. The resulting effects on the test materials are observed and measured.

5 Health and safety of test personnel

5.1 General

WARNING — The following test requirements call for the use of procedures that may be hazardous to health if adequate precautions are not taken.

These precautions are drawn from ISO 8191-1:1987, Clause 6.

Ensure that there is no hidden smouldering of the sample before disposal.

5.2 Enclosure

For safety, the tests should be conducted in a non-combustible fume cupboard. If such a cupboard is not available, a test enclosure should be constructed (see [6.2](#)) so that the operator is protected from the fumes.

5.3 Extinguishers

Adequate means of extinguishing the assembly should be provided, bearing in mind that some combinations may produce severe flaming during the test. A hand and/or a fixed water spray which can be directed over the burning area can be useful. Other means such as fire extinguishers (water and halogenated hydrocarbons), fire blankets, and a bucket of water will assist. In some cases smouldering may be difficult to extinguish completely and complete immersion in water may be necessary.

6 Apparatus

6.1 Test rig

The test rig in ISO 8191-1:1987 may be used as described.

NOTE The frame of the test rig described as the back frame with a width of $450 \text{ mm} \pm 2 \text{ mm}$, but with a height of $450 \text{ mm} \pm 2 \text{ mm}$ can be used for both the horizontal and vertical tests.

6.2 Test enclosure

The test enclosure shall consist of either a room with a volume greater than 20 m^3 (which contains adequate oxygen for testing) or a smaller enclosure with a through flow of air. Inlet and extraction systems providing air flows of $0,02 \text{ m/s}$ to $0,2 \text{ m/s}$ in the locality of the rig provide adequate oxygen without disturbing the burning behaviour.

NOTE This enclosure is the equivalent to that specified in ISO 8191-1:1987, 7.2.

6.3 Timer

A means of measuring time for a period of 5 s to 1 000 s with an accuracy of $\pm 0,1 \text{ s}$.

6.4 Heat source

A temperature controlled heat source consisting of two separate parts.

a) A heat source complying with the following:

- $8 \text{ mm} \pm 0,5 \text{ mm}$ diameter;
- $75 \text{ mm} \pm 5 \text{ mm}$ heated length;
- $100 \text{ W} \pm 20 \text{ W}$ heat output;
- K-type thermocouple integrated in the centre of the heat source;
- minimum wire length of 3 m;
- heat resistant wire insulation;
- a fixture to hold the heat source in place throughout the test, designed to avoid burns while handling the heat source.

b) A temperature controller complying with the following:

- temperature controller with automatic identification of the control area or model based tuning of the controller parameters;
- the test cycle commences when the temperature value of $150 \text{ }^\circ\text{C}$ has been reached;
- the temperature values follow the temperature heating curve in [Figure 1](#) and [Table 1](#) automatically during the test cycle.

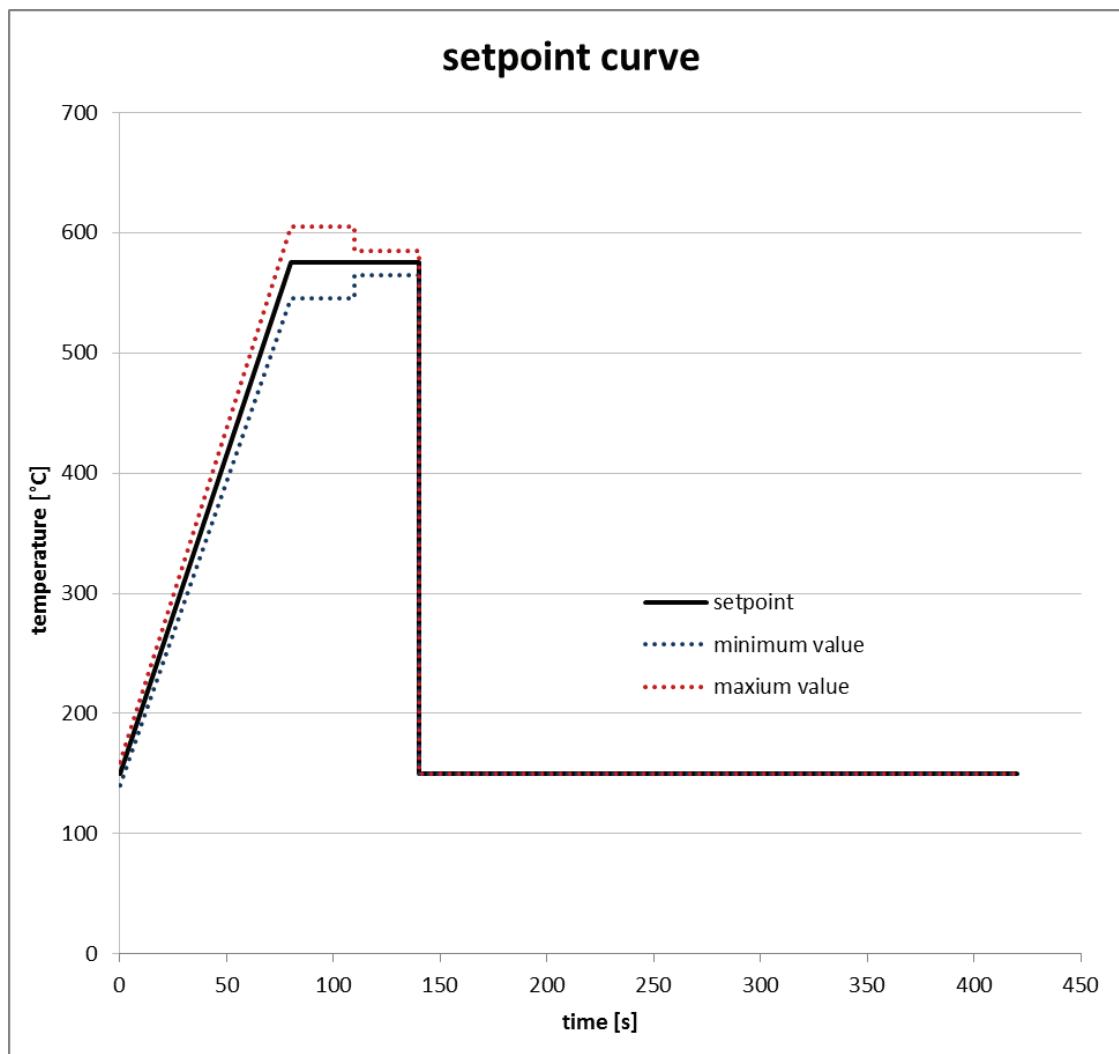

Figure 1 — Temperature-time-diagram of the test cycle with set point curve and allowed offset

Table 1 — Set point table for the test

	Duration	Initial set point	Final set point
Ramp	80 s ± 20 s	150 °C ± 10 °C	575 ± 30 °C
Plateau	30 s ± 1 s	575 °C ± 30 °C	575 °C ± 10 °C
Plateau	30 s ± 1 s	575 °C ± 10 °C	575 °C ± 10 °C
Cooling	Variable	575 °C ± 10 °C	150 °C ± 10 °C

NOTE 1 [Annex A](#) provides details of an apparatus that meets these specifications

NOTE 2 This source has been designed to give a calorific output approximating to that of a stabilized smouldering cigarette (ISO 8191-1:1987).

6.5 Conditioning environment

Prior to conditioning described below, all outer cover materials shall be subjected to the washing and drying procedures described in [Annex B](#).

An environment with an atmosphere which can be maintained for up to 20 h at a temperature of 23 °C ± 2 °C and relative humidity of 50 % ± 5 % as specified in ISO 554.

6.6 Test environment

An environment in which the test procedure in [Clause 7](#) can be conducted and which has an atmosphere with a temperature between 10 °C and 30 °C and a relative humidity between 15 % and 80 %.

In the area of the test rig within 100 mm ± 5 mm of the heat source, the airflow shall be less than 0,02 m/s

6.7 Test sample

A sample consisting of the materials assembled as used which shall be made up of cover, filling, and any other components, such as an interliner, which may be used in a real assembly. The sample shall have dimensions comprising of a minimum width of 300 mm and a maximum width of 450 mm, and a depth or length of a minimum of 300 mm and a maximum of 450 mm. A manufactured non-integrated seat or back support cushion provided that it is no smaller than the minimum dimensions or no larger than the maximum dimensions specified above may be used.

Spray-on flame retardant substances shall not be relied on unless the durability of their effectiveness for the life of the manufactured part is confirmed.

NOTE 1 If the cushion is designed to be used only with its cover, then the test sample shall include that cover.

NOTE 2 If the cushion is designed to be used only with its cover from a choice of covers, each cover option shall be tested separately in combination with that cushion.

NOTE 3 If the cushion is designed to be used either with or without its cover, then the cushion shall be tested with and without its cover.

7 Test procedure

7.1 Preparation

- a) Identify the removable seat or back support cushion.
- b) If testing items which are intended to be used only in the range of the horizontal plane ± 30°, use the horizontal test, and for all other supports use the vertical test. If the part is intended for use in either plane, then use both tests.
- c) Attach the test sample(s) to the test rig(s).
- d) Place the test rig and sample in the conditioning environment for a minimum of 16 h.
- e) Ensure the heat source is below 50 °C.

7.2 Horizontal test

- a) Set up the test sample mounted in the test rig in a horizontal orientation (of the contact surface) in the test environment.
- b) Apply the heat source specified in [6.4](#) within 50 mm of the centre of the top surface as possible and parallel to the top surface of the test sample with no pressure from the heat source, nor a gap between the heat source and the sample.
- c) Switch on the heat source and make sure the actual temperature value of the heat source is 150 °C ± 30 °C before starting the test cycle.
- d) Start the test cycle. Observe the subsequent progress of combustion, and record any evidence of progressive smouldering, or flaming in the interior and/or surface. Disregard any afterglow, smoking, or smouldering that ceases within 10 s of the end of the plateau of the heat temperature curves. Allow the heat source to cool down to 150 °C or less before removing it from the sample.

- e) Ensure the heat source is below 50 °C.
- f) Repeat a) to d) once on a new or the same test sample in an unaffected area.

7.3 Vertical test

Perform the test specified in [7.2](#), but with the following:

- a) The test rig supported in a vertical configuration (of the contact surface);
- b) Apply the heat source specified in [6.4](#) half way ± 50 mm across the test sample in the width dimension and at a distance of $(0,1 h + 20)$ mm ± 10 % above the lowest side of the test sample where h = total length of the test sample in mm in the length dimension;
- c) Align the heat source in the horizontal plane $\pm 3^\circ$ and parallel to the contact surface of the test sample with no pressure from the heat source, nor a gap between the heat source and the sample.

8 Requirements

In horizontal and vertical orientations, when subjected to the heat source specified in [6.4](#), removable seat or back support cushions used in a wheelchair shall

- a) show no evidence of flaming in the interior and/or surface during or after the test, and
- b) show no evidence of progressive smouldering 10 s \pm 1 s after the end of the maximum temperature plateau of the temperature heating curve.

9 Test report

The test report shall include the following:

- a) a statement that “The following test results relate only to the ignitability of the combination of materials under the particular conditions of the test. They are not intended as a means of assessing the full potential hazard of the complete wheelchair”;
- b) identification and construction of the test samples;
- c) date of the test report;
- d) name and address, and accreditation status, of the test institution;
- e) name and address of the manufacturer(s) of the test sample tested;
- f) materials references, a brief description, and any batch or serial numbers;
- g) photographs of the end result of the test;
- h) results of the tests carried out, and a statement as to whether the materials met the requirements of this part of ISO 16840 with the exception of [Clause 10](#);
- i) a unique test report reference.

10 Disclosure of results

Manufacturers shall disclose in their specification sheet(s), in the manner and sequence specified in ISO 7176-15:

- a) if the non-integrated seat or back support cushions met the requirements of this part of ISO 16840,
- b) the rationale why this part of ISO 16840 rather than ISO 7176-16:2012 was selected for testing,

- c) that resistance to ignition may change with use, ageing, and/or cleaning,
- d) that precautions should be taken to avoid sources of ignition, including flames, cigarettes, etc.,
- e) that the environment (such as oxygen, alcohol, etc.) of the user may increase the risk of ignition,
- f) whether the cushion is designed to be used either with or without its cover, or only with a specified cover, and has been tested as such.

NOTE The results of this test do not give any indication of the resistance to ignition of any of the separate individual components of the test sample, unless stated otherwise.

Annex A (informative)

Design of a heat source as a surrogate cigarette device

[Annex A](#) provides details of a heat source that meets the specifications in this part of ISO 16840. The heat source consists of two main parts. The heat source is realised by a heating cartridge with glass silk isolated wires and a 90° pipe adapter to be fastened at the fixture. The digital temperature controller triggers the solid state relay and provides a button to start the test cycle. [Table A.1](#) provides a parts list where accessories are included. [Figure A.1](#) shows the connection diagram for 230 VAC mains voltage. While the temperature controller works with 115 VAC to 230 VAC the heat source can easily be changed for use with another mains voltage. For that purpose a different heating cartridge is needed that provides the requested $100\text{ W} \pm 20\text{ W}$ power consumption at the specified mains voltage. [Table A.2](#) shows the parameters for programming the HotControl C248 from the HotSet company. Note that some parameters are identified automatically during the identification of the control area.

Table A.1 — Parts list

Item No	Element	Description
1	Temperature controller	HotSet Hotcontrol C248
2	Heating cartridge with thermo sensor	HotSet Hotrod HHP 8 mm × 80 mm 250 V 100 W K-type thermo-couple
3	Box base	2 Fischer Elektronik KOH6
4	Cover	2 Fischer Elektronik H6
5	Soils state relay	Crydom D2425 250 V 16 A
6	Protective cover for relay	Crydom D2425
7	Connector	Hirschmann Ca-6 GD
8	Connector	Hirschmann Ca-6 LS
9	Power entry module including fuse holder and main switch	Schorter KM
10	Fuse holder for power entry module	Schorter KM
11	Power cable	1,8 m
12	3 Fuse holders	
13	3 Fuses	2 250 V 0,63A F 1 250 V 0,2A T (delayed)
14	Start button	Push button
15	Consumables	Cables, eyelets, screws, etc.

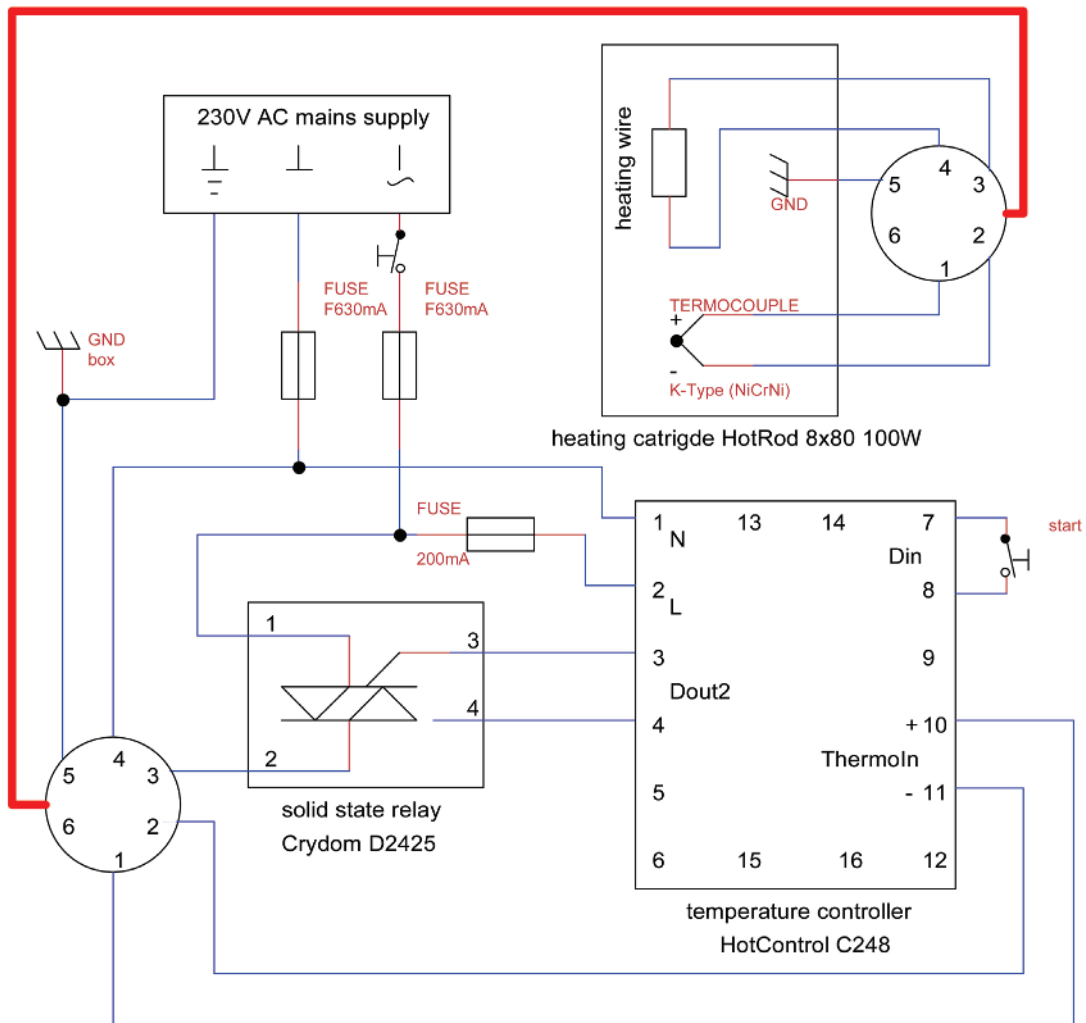

Figure A.1 — Connection diagram

Table A.2 — Parameters for HotSet HotControl C248 temperature controller

Parameter	Value	Default	Parameter	Value	Default	Parameter	Value	Default
sp	150		sp.cb	0	✓	sen.s	off	✓
manu	Off	✓	gp.rt	0	✓	off.a	0	✓
out	0	✓	gp.nr	0	✓	off.b	0-10	✓
cur.s	0	✓	gp.fu	0	✓	off.c	0-20	✓
cur.t	20	✓	li.1d	0	✓	aib.l	0	✓
zone	On	✓	li.2d	0	✓	aib.h	999	✓
li.1	5	✓	li.3d	0	✓	aic.l	4	✓
li.2	-5	✓	li.4d	0	✓	aAic.h	999	✓
li.3	0	✓	out.h	100	✓	a1.d1	4	✓
li.4	0	✓	out.c	-100	✓	a1.d2	0	✓
sp.2	575		out.m	100	✓	a2.d1	8	✓
sp.3	575		Cool	Off	✓	a2.d2	0	✓

Table A.2 (continued)

Parameter	Value	Default	Parameter	Value	Default	Parameter	Value	Default
Sp.4	150		rel.h	Off	✓	a3.d1	2	✓
rap.t	425		rel.c	On	✓	a3.d2	0	✓
rap.a	Off	✓	sp.lo	0	✓	a4.d1	1	✓
rap.g	5	✓	sp.hi	600		a4.d2	0	✓
t1	60		cur.d	0		t1.d1	sp2.a	
t2	60		cur.e	100	✓	t1.d2	t2	
t3	300		Cels	C	✓	t2.d1	sp3.a	
t4	0	✓	Decp	0,1		t2.d2	t3	
aman	Off	✓	Dman	out	✓	t3.d1	sp4.a	
tc.al	On		Do 0,1	heat	✓	t3.d2	off	✓
tc.ti	8		Do 0,2	off		t4.d1	off	✓
appl	0	✓	Do 0,3	off	✓	t4.d2	off	✓
h.pb	11,9		Do 0,4	Off	✓	t.res	run	✓
h.td	4		Din.1	t1		edit	on	✓
h.ti	15		Din.2	off	✓	iloc	on	
h.ct	0,2		opt.a	off	✓	s,adr	0	✓
c.pb	16,6		opt.b	off	✓	s.pro	P562	✓
c.td	4		do.a	off	✓	s.bd	19,2	✓
c.ti	15		do.b	off	✓	s.par	no	✓
c.ct	10		din.a	off	✓	s.sto	1	✓
Ide.h	Off		din.b	off	✓	c.bas	32	✓
Ide.c	Off	✓	ao.a	off	✓	c.bd	250	✓
Ide.i	Off	✓	ao.b	off	✓	c.op	auto	✓
c.com	Off	✓	Sen	nicr		m.adr	1	✓

Annex B (normative)

Conditioning of outer cover materials by washing and drying procedures

B.1 General

Water Soak procedures are as in EN 1021-1: 2006, Annex D.

B.2 Reagents

B.2.1 Water

A supply of water with a degree of hardness of 8 dH to 10 dH (80 mg/l CaO to 100 mg/l CaO).

If the water is harder than 10 dH, demineralised water shall be added until the required degree of hardness is achieved. The quantity of demineralised water to be added to 1 L of water with a degree of hardness D (>10 dH) is $(D-9)/9$ L.

EXAMPLE 1 To 5 L water with a degree of hardness 13,4 dH, $5 \times (13,4 - 9)/9 = 2,44$ L demineralised water shall be added to obtain 7,44 L water with a degree of hardness of 9 dH.

If the water is softer than 8 dH, salts shall be added in order to increase the hardness. Two solutions shall be prepared:

Solution I:

Dissolve 3,91 g calcium chloride ($\text{CaCl}_2 \cdot 6\text{H}_2\text{O}$) in 1 L demineralised or distilled water.

Solution II:

Dissolve 3,00 g sodium bicarbonate (NaHCO_3) in 1 L demineralised or distilled water.

The quantity of these two solutions to be added to 1 L water of a degree of hardness of D (<8 dH), is $12,2(9-D)$ ml.

EXAMPLE 2 To 10 L water with a degree of hardness 7.0 dH, $10 \times 12,2 (9 - 7) = 244$ ml of Solution I and an equal amount of Solution II shall be added to obtain 10,49 L water with a degree of hardness of 9 dH.

B.2.2 Wetting agent

Any non-ionic wetting agent.

NOTE The exact nature of this reagent is not critical.

B.3 Apparatus

Flat bottomed dish of sufficient size to enable the test specimens to be completely immersed.

B.4 Specimens

Use sufficient cover material to permit subsequent preparation of a test specimen of the dimensions described in [6.7](#).

NOTE Depending on the dimensions of the flat bottomed dish ([B.3](#)) the specimen may require folding.

B.5 Procedure

Using a liquor ratio (sample mass: water mass) of 1:20, completely immerse each specimen in water ([B.2.1](#)) containing 0.5 g/l of non-ionic wetting agent ([B.2.2](#)) in a flat bottomed dish ([B.3](#)) at an initial temperature of (40 ± 1) °C. Ensure the specimen remains completely immersed.

After 30 min, remove the specimen, rinse in water ([B.2.1](#)) using a liquor ratio of 1:20 for 2 min and then dry the specimen by hanging it vertically from the shorter edge nearest to the cut outs so that it is not in contact with other specimens, materials, or surfaces. After drying it shall then be conditioned for a minimum of 24 h at 23 °C/50 % RH. If the specimen has been folded during immersion, refold before rinsing.

NOTE Drying time will vary with different covers, but a time of 48 h in indoor ambient conditions should be satisfactory for most fabrics.

Bibliography

- [1] ISO 7176-14, *Wheelchairs — Part 14: Power and control systems for electrically powered wheelchairs and scooters — Requirements and test methods*
- [2] ISO 7176-15, *Wheelchairs — Part 15: Requirements for information disclosure, documentation and labelling*
- [3] ISO 7176-16, *Wheelchairs — Part 16: Resistance to ignition of postural support devices*
- [4] ISO 7176-26, *Wheelchairs — Part 26: Vocabulary*
- [5] ISO 8191-1:1987, *Furniture — Assessment of the ignitability of upholstered furniture — Part 1: Ignition source: smouldering cigarette*
- [6] ISO 10993-1, *Biological evaluation of medical devices — Part 1: Evaluation and testing within a risk management process*
- [7] ISO 10993-10, *Biological evaluation of medical devices — Part 10: Tests for irritation and skin sensitization*
- [8] DIESING P Development of a surrogate replacement for a cigarette for use in flammability testing, In preparation

British Standards Institution (BSI)

BSI is the national body responsible for preparing British Standards and other standards-related publications, information and services.

BSI is incorporated by Royal Charter. British Standards and other standardization products are published by BSI Standards Limited.

About us

We bring together business, industry, government, consumers, innovators and others to shape their combined experience and expertise into standards-based solutions.

The knowledge embodied in our standards has been carefully assembled in a dependable format and refined through our open consultation process. Organizations of all sizes and across all sectors choose standards to help them achieve their goals.

Information on standards

We can provide you with the knowledge that your organization needs to succeed. Find out more about British Standards by visiting our website at bsigroup.com/standards or contacting our Customer Services team or Knowledge Centre.

Buying standards

You can buy and download PDF versions of BSI publications, including British and adopted European and international standards, through our website at bsigroup.com/shop, where hard copies can also be purchased.

If you need international and foreign standards from other Standards Development Organizations, hard copies can be ordered from our Customer Services team.

Subscriptions

Our range of subscription services are designed to make using standards easier for you. For further information on our subscription products go to bsigroup.com/subscriptions.

With **British Standards Online (BSOL)** you'll have instant access to over 55,000 British and adopted European and international standards from your desktop. It's available 24/7 and is refreshed daily so you'll always be up to date.

You can keep in touch with standards developments and receive substantial discounts on the purchase price of standards, both in single copy and subscription format, by becoming a **BSI Subscribing Member**.

PLUS is an updating service exclusive to BSI Subscribing Members. You will automatically receive the latest hard copy of your standards when they're revised or replaced.

To find out more about becoming a BSI Subscribing Member and the benefits of membership, please visit bsigroup.com/shop.

With a **Multi-User Network Licence (MUNL)** you are able to host standards publications on your intranet. Licences can cover as few or as many users as you wish. With updates supplied as soon as they're available, you can be sure your documentation is current. For further information, email bsmusales@bsigroup.com.

BSI Group Headquarters

389 Chiswick High Road London W4 4AL UK

Revisions

Our British Standards and other publications are updated by amendment or revision.

We continually improve the quality of our products and services to benefit your business. If you find an inaccuracy or ambiguity within a British Standard or other BSI publication please inform the Knowledge Centre.

Copyright

All the data, software and documentation set out in all British Standards and other BSI publications are the property of and copyrighted by BSI, or some person or entity that owns copyright in the information used (such as the international standardization bodies) and has formally licensed such information to BSI for commercial publication and use. Except as permitted under the Copyright, Designs and Patents Act 1988 no extract may be reproduced, stored in a retrieval system or transmitted in any form or by any means – electronic, photocopying, recording or otherwise – without prior written permission from BSI. Details and advice can be obtained from the Copyright & Licensing Department.

Useful Contacts:

Customer Services

Tel: +44 845 086 9001

Email (orders): orders@bsigroup.com

Email (enquiries): cservices@bsigroup.com

Subscriptions

Tel: +44 845 086 9001

Email: subscriptions@bsigroup.com

Knowledge Centre

Tel: +44 20 8996 7004

Email: knowledgecentre@bsigroup.com

Copyright & Licensing

Tel: +44 20 8996 7070

Email: copyright@bsigroup.com



...making excellence a habit.™