

BS ISO 16787:2016



BSI Standards Publication

Intelligent transport systems — Assisted Parking System (APS) — Performance requirements and test procedures

National foreword

This British Standard is the UK implementation of ISO 16787:2016.

The UK participation in its preparation was entrusted to Technical Committee EPL/278, Intelligent transport systems.

A list of organizations represented on this committee can be obtained on request to its secretary.

This publication does not purport to include all the necessary provisions of a contract. Users are responsible for its correct application.

© The British Standards Institution 2016.
Published by BSI Standards Limited 2016

ISBN 978 0 580 84711 0

ICS 35.240.60

Compliance with a British Standard cannot confer immunity from legal obligations.

This British Standard was published under the authority of the Standards Policy and Strategy Committee on 30 November 2016.

Amendments/corrigenda issued since publication

Date	Text affected
------	---------------

**Intelligent transport systems —
Assisted Parking System (APS) —
Performance requirements and test
procedures**

*Systèmes intelligents de transport — Système de stationnement assisté
(APS) — Exigences de performance et modes opératoires d'essai*



COPYRIGHT PROTECTED DOCUMENT

© ISO 2016, Published in Switzerland

All rights reserved. Unless otherwise specified, no part of this publication may be reproduced or utilized otherwise in any form or by any means, electronic or mechanical, including photocopying, or posting on the internet or an intranet, without prior written permission. Permission can be requested from either ISO at the address below or ISO's member body in the country of the requester.

ISO copyright office
Ch. de Blandonnet 8 • CP 401
CH-1214 Vernier, Geneva, Switzerland
Tel. +41 22 749 01 11
Fax +41 22 749 09 47
copyright@iso.org
www.iso.org

Contents

Page

Foreword	v
Introduction	vi
1 Scope	1
2 Normative references	1
3 Terms and definitions	1
4 Definition of APS type and common requirements	3
4.1 Basic system functionality.....	3
4.2 APS types.....	3
4.3 Common requirements.....	3
4.3.1 Maximum speed during operation.....	3
4.3.2 APS exit conditions.....	3
4.3.4 Advisory note.....	4
5 Functional and performance requirements APS type 1	4
5.1 Basic system functionality.....	4
5.1.1 Parking slot type 1 parallel.....	4
5.1.2 Parking slot type 1 perpendicular.....	5
5.1.3 APS operation sequence.....	5
5.1.4 Basic operation procedure of APS.....	5
5.1.5 Quiescent mode.....	6
5.1.6 Slot search.....	6
5.1.7 Slot found.....	6
5.1.8 Target parking slot recognition.....	6
5.1.9 Assisted parking mode.....	6
5.1.10 End of assisted parking mode.....	6
5.1.11 APS diagram of operating modes (APS type 1).....	6
5.2 Driver interface and information strategy.....	7
5.2.1 General information presentation.....	7
5.2.2 Information in the slot search mode.....	7
5.2.3 Information during “slot found” until “start of assisted parking”.....	7
5.2.4 Driver request.....	8
5.2.5 Information during assisted parking.....	8
5.2.6 Information at “end of assisted parking”.....	8
5.3 Minimum performance requirements.....	8
5.3.1 Performance requirements during slot search mode.....	8
5.3.2 Performance requirements during assisted parking mode.....	8
5.4 Performance test requirements (APS type 1).....	11
5.4.1 Test objects.....	11
5.4.2 Ambient conditions — General.....	11
5.4.3 Test criteria.....	11
5.4.4 Slot search tests.....	11
5.4.5 Test of supported speed during assisted parking.....	12
5.4.6 End position tests.....	12
6 Functional and performance requirements APS type 2	13
6.1 Basic system functionality.....	13
6.1.1 Basic function.....	13
6.1.2 Geometric requirements.....	14
6.1.3 APS diagram of operating modes (APS type 2).....	15
6.2 Driver interface and information strategy.....	16
6.2.1 Operation procedure.....	16
6.2.2 Basic operation procedure of APS.....	16
6.3 Minimum performance requirements.....	17
6.3.1 Defined parking slot.....	17

6.3.2	Target slot recognition.....	18
6.3.3	Maximum speed during operation.....	18
6.3.4	Performance requirements for the end position.....	18
6.4	Performance test requirements.....	21
6.4.1	Performance test conditions.....	21
6.4.2	Parking slot recognition test.....	21
6.4.3	Environmental conditions — General.....	23
6.4.4	Test criteria.....	23
6.4.5	End position tests.....	23
Annex A (informative) Example of APS operation sequence.....		25
Bibliography.....		28

Foreword

ISO (the International Organization for Standardization) is a worldwide federation of national standards bodies (ISO member bodies). The work of preparing International Standards is normally carried out through ISO technical committees. Each member body interested in a subject for which a technical committee has been established has the right to be represented on that committee. International organizations, governmental and non-governmental, in liaison with ISO, also take part in the work. ISO collaborates closely with the International Electrotechnical Commission (IEC) on all matters of electrotechnical standardization.

The procedures used to develop this document and those intended for its further maintenance are described in the ISO/IEC Directives, Part 1. In particular the different approval criteria needed for the different types of ISO documents should be noted. This document was drafted in accordance with the editorial rules of the ISO/IEC Directives, Part 2 (see www.iso.org/directives).

Attention is drawn to the possibility that some of the elements of this document may be the subject of patent rights. ISO shall not be held responsible for identifying any or all such patent rights. Details of any patent rights identified during the development of the document will be in the Introduction and/or on the ISO list of patent declarations received (see www.iso.org/patents).

Any trade name used in this document is information given for the convenience of users and does not constitute an endorsement.

For an explanation on the meaning of ISO specific terms and expressions related to conformity assessment, as well as information about ISO's adherence to the World Trade Organization (WTO) principles in the Technical Barriers to Trade (TBT) see the following URL: www.iso.org/iso/foreword.html.

The committee responsible for this document is ISO/TC 204, *Intelligent transport systems*.

Introduction

Assisted Parking Systems (APS) consist of non-contact sensors and steering control which assist the driver in parking the vehicle. The assistance starts with searching a suitable parking area, getting information on the area around the vehicle (environmental map), calculating the trajectory and finishes with the lateral control of the vehicle. APS also assist the driver in recognizing obstacles while manoeuvring into the parking slot.

Intelligent transport systems — Assisted Parking System (APS) — Performance requirements and test procedures

1 Scope

This document for Assisted Parking System (APS) addresses light-duty vehicles, e.g. passenger cars, pick-up trucks, light vans and sport utility vehicles (motorcycles excluded) equipped with such APS. This document establishes minimum functionality requirements that the driver can expect of the system, such as the detection of suitable parking spaces, calculation of trajectories and lateral control of the vehicle. Information on the presence of relevant obstacles in the driving path of the vehicle can also be included in the functionality of such systems. This document also sets minimum requirements for failure indication as well as performance test procedures. It includes rules for the general information strategy, but does not restrict the kind of information or display system.

APS is intended to provide automated parking assistance functionality to the driver. The APS searches the environment adjacent to the vehicle for suitable parking areas between other parked vehicles or markings on the road such as painted lines, evaluates the required information to calculate parking trajectories and sends steering commands to an electronic interface of the steering system for lateral control of the vehicle during the parking manoeuvre.

The basic APS function is to assist the driver with lateral control of the vehicle during parking manoeuvres. As an optional extension, APS may also offer limited longitudinal control of the vehicle movement, e.g. braking assistance while manoeuvring into the parking slot.

This document contains requirements for the lateral control capability of APS. It does not address longitudinal control.

During the parking manoeuvre, the driver can take over the control of the vehicle movement at any time and is also fully responsible for the parking manoeuvre.

APS uses object-detection devices for detection and ranging in order to search the environment for suitable parking areas. Such devices can be sensors with distance information or vision-based systems. In addition, sensors or counters, as well as relevant data available on the vehicle network (e.g. CAN), may be used to calculate the position of the vehicle relative to the parking area.

APS is an extension of systems which inform the driver about obstacles in parking manoeuvres (e.g. ISO 17386 and ISO 22840).

This document does not include Assisted Parking Systems, reversing aids and obstacle-detection devices for use on heavy commercial vehicles or on vehicles with trailers.

2 Normative references

There are no normative references in this document.

3 Terms and definitions

For the purposes of this document, the following terms and definitions apply.

ISO and IEC maintain terminological databases for use in standardization at the following addresses:

- IEC Electropedia: available at <http://www.electropedia.org/>
- ISO Online browsing platform: available at <https://www.iso.org/obp/>

3.1
Assisted Parking System
APS

system capable of measuring the dimensions of a parking slot, calculating an applicable trajectory, performing lateral control of the vehicle while manoeuvring into the slot and giving needed instructions to the driver

3.2
slot search mode

operation mode in which the *APS* (3.1) searches the environment for suitable parking slots

3.3
assisted parking mode

automated lateral control (i.e. steering) of the vehicle by the *APS* (3.1) during the parking manoeuvre while the driver has control of the vehicle speed and driving direction

3.4
system activation

action of transitioning the system operation from a quiescent mode to an active one

3.5
driver assistance request

unique interaction between driver and user interface which is required to enable the *APS* (3.1) before each active parking manoeuvre

3.6
audible information and warning

acoustical signal (e.g. pulses, speech) which is used to present relevant information to the driver

3.7
visual information and warning

optical signal (e.g. a telltale or display) which is used to present relevant information to the driver

3.8
sensor system

component or set of components which detects objects in the monitoring range

3.9
test object

object with a specific material, geometry and surface for testing the monitoring range

3.10
searching range

minimum area in which *APS* (3.1) is able to search the environment for suitable parking slots

3.11
APS exit condition

condition after *system activation* (3.4) which causes the *APS* (3.1) to abort the manoeuvring support

3.12
APS end condition

assisted parking manoeuvre is finished and *APS* (3.1) gives the full control of the vehicle back to the driver

3.13
bordering vehicle

vehicle that limits the parking slot to the rear or the front

3.14
APS vehicle

vehicle which is equipped with *APS* (3.1)

3.15

V_{search_max}

requirement up to which maximum speed *APS* (3.1) shall be able to search the environment for suitable parking slots

3.16

parking slot defining line(s)

painted lines on the ground surface in a bright colour to identify the boundary of a defined parking slot

3.17

ambient illuminance

characteristic of the brightness of the scene of which the image sensor captures the image

4 Definition of APS type and common requirements

4.1 Basic system functionality

The APS recognizes a parking slot where the vehicle can be parked, determines the target parking position and calculates the parking trajectory.

The APS guides the vehicle to the target parking position by automatically controlling the steering during a parking manoeuvre. Upon completion of control, the vehicle's position relative to the target parking position shall fulfil a certain accuracy requirement.

4.2 APS types

This document addresses the practical systems available in the market because the driver's parking behaviour and urban parking conditions are unique issues for each country or district. Two APS type definitions according to the system's target parking slot follow.

APS type 1: The APS whose target slot is the space between two vehicles.

APS type 2: The APS whose target slot is defined by markings such as painted lines.

For both types, parallel and perpendicular slots are possible.

4.3 Common requirements

4.3.1 Maximum speed during operation

It is recommended to limit the speed range during assisted parking and abort the assisted parking mode for safety when the driver exceeds this limit. The recommended range for the speed limit is [Forward: 10 km/h Reverse: 7 km/h to 12 km/h]. However, this speed limit shall conform to local regulatory requirements such as internal law, technical guidelines.

4.3.2 APS exit conditions

APS shall abort the assisted parking mode if one or more of the following conditions apply.

- The driver operates the steering to take over the control. Minimum torque to the steering wheel shall be defined by OEM. Typical value could be approximately 5 Nm.
- There is a system internal failure detected by the APS.
- The vehicle exceeds the speed limit for the assisted parking mode, as specified in 4.3.1.

The system shall cancel automatic steering control and give both audible and visual information to the driver upon detecting malfunctions.

4.3.4 Advisory note

The APS, as described in this document, is intended to detect suitable parking slots and steer the vehicle during the parking manoeuvre. It is recommended that the vehicle operator's handbook (owner's manual) include an advisory note that clearly indicates how to use the system and include a description of abort criteria, driver's responsibility and limitations of the system.

It shall particularly remind the driver of his responsibility for safety while manoeuvring into the parking slot. This includes taking care of obstructions and other possible hazards that may not be detected by the APS. Especially in case of perpendicular parking slots, the driver must ensure that the depth of the parking slot is sufficient. If there is an unsafe condition detected by the system, the driver shall be advised not to start the manoeuvre or to immediately take over the control of the vehicle movement.

APS shall also assist the driver in recognizing obstacles while manoeuvring into the parking slot. Examples of such systems are described by MALSO (ISO 17386), ERBA (ISO 22840) International Standards or rear viewing camera systems.

5 Functional and performance requirements APS type 1

5.1 Basic system functionality

APS type 1 shall support either parallel or perpendicular or both types of parking slots.

5.1.1 Parking slot type 1 parallel

The parking manoeuvre shall be performed with a parking slot limited by two vehicles of similar model as the subject vehicle and an optional kerb as a lateral reference. It is recommended that the system is able to detect a reference kerb, as described in [Figure 9](#).

For this document, it is recommended that the bordering vehicles are aligned in the same direction and parallel to each other. The document parking slot length x_0 is defined as the length of the APS vehicle plus Δx_p and the slot depth y_0 is defined as the width of the APS vehicle plus 0,2 m. For the test parking scene, two situations are considered, either with or without a reference kerb. In the case with a reference kerb, the vehicles are parked with a fixed distance parallel to it. In a situation without kerb, the virtual connecting line between the outer borders of the parked vehicles projected onto the ground is the lateral reference line.

The parking slot is defined by its length x_0 and its depth y_0 (as shown in [Figure 1](#)). x_0 is the distance between the two reference vehicles. The depth y_0 is the distance between the outer border line of the reference vehicle and the kerb.

For APS vehicle length between 4 m and 6 m, $\Delta x_p = \text{length of APS vehicle} \times 0,25$. For small vehicles, (≤ 4 m): $\Delta x_p = 4 \text{ m} \times 0,25 = 1,0 \text{ m}$ and for large vehicles, (≥ 6 m) $\Delta x_p = 6 \text{ m} \times 0,25 = 1,5 \text{ m}$.

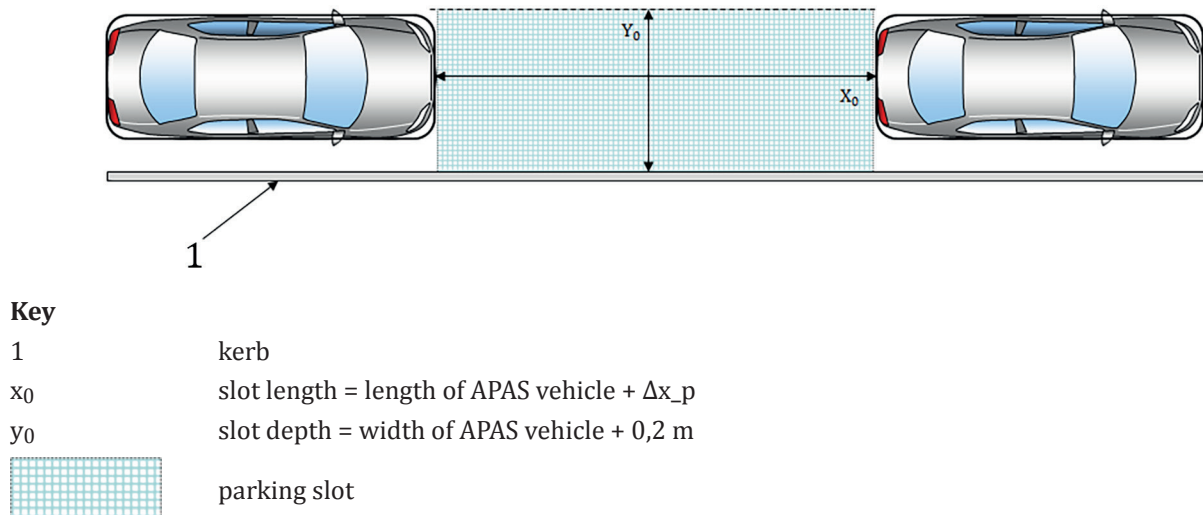

Figure 1 — Geometry of a parking slot type 1 parallel

5.1.2 Parking slot type 1 perpendicular

As a minimum requirement, the parking manoeuvre shall be performed with a parking slot limited by two vehicles of a similar model as the subject vehicle. Compliance with this document may also be proven using vehicles of different types.

For this document, it is recommended that the bordering vehicles are aligned in the same direction as the APS vehicle in its target position and parallel to each other. The standard parking slot width x_0 is defined as the width of the APS vehicle plus Δx_l and the slot depth y_0 is minimum length of APS vehicle. $\Delta x_l = 1,2$ m. See [Figure 2](#).

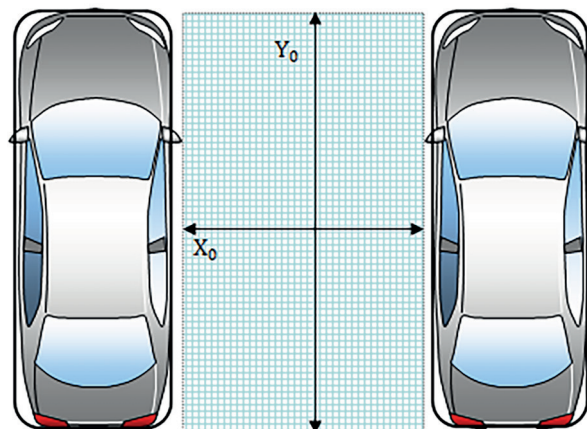

Figure 2 — Geometry of parking slot type 1 perpendicular

5.1.3 APS operation sequence

For APS type 1, see [Figure 3](#).

5.1.4 Basic operation procedure of APS

For APS type 1, see [Figure 3](#).

5.1.5 Quiescent mode

APS type 1: If activation conditions are not fulfilled, the APS shall not perform any action.

5.1.6 Slot search

APS type 1: Below a certain speed ($v_{\text{search_max}}$) and if activation conditions are fulfilled, the APS starts to search the environment for suitable parking slots. The system shall be able to search and park in the direction of both the driver and the passenger side. Depending on the system design, the driver may be able to choose the types of supported parking slots during slot search (for example, perpendicular only, parallel or perpendicular, driver side only, driver and passenger side, etc.). Due to physical limitations of the sensing system, there may be obstructions within the parking slot that are not detected by the APS, but may interfere with parking in the detected slot. Furthermore, in case of perpendicular parking slots, the obstacle detection systems may not cover the whole parking space depth.

5.1.7 Slot found

APS type 1: The system shall inform the driver about potentially suitable parking slots found. The driver needs to check the parking slot for obstructions before proceeding with the next step.

5.1.8 Target parking slot recognition

Type 1: The APS informs the driver when the vehicle arrives at the position where parking assist is possible.

5.1.9 Assisted parking mode

When the driver decides to park into the suitable parking slot and stops the vehicle, the APS shall assist the driver with advice and by actuating the steering during the parking manoeuvre. The ability of the system to support the parking manoeuvre will depend on the actual starting position of the APS vehicle relative to the parking slot. The limitations of the permissible starting positions shall be described in the owner's manual of the vehicle.

The actuation of the steering shall not start before the vehicle stands still.

The driver shall be able to finish the parking manoeuvre by taking over lateral control of the APS vehicle at any time. In this case, the APS shall terminate the automated actuation of the steering immediately.

5.1.10 End of assisted parking mode

The driver shall be informed when the parking manoeuvre is finished or aborted.

5.1.11 APS diagram of operating modes (APS type 1)

The following diagram shows an example sequence of operating modes, the corresponding information presented to the driver in each operating mode and also, which activity is required by the driver.

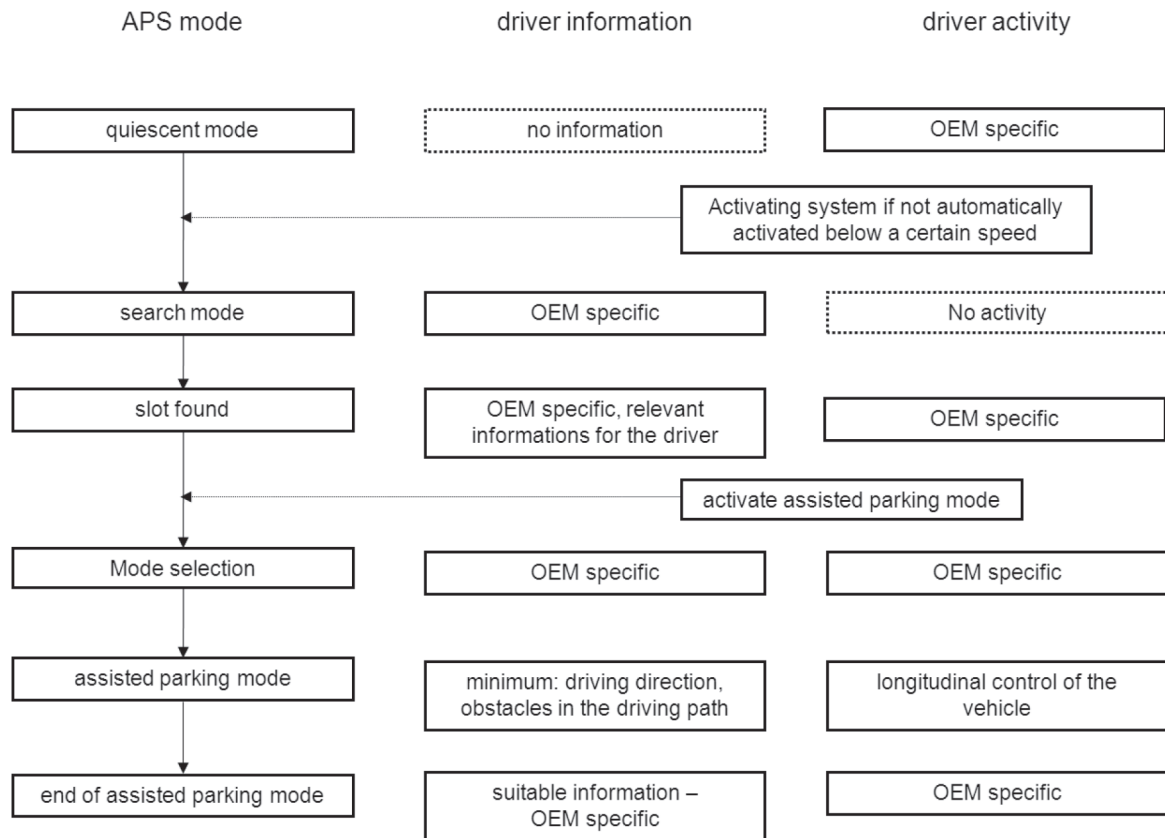

Figure 3 — APS diagram of operating modes (APS type 1)

Advancement to the next mode is only possible, if the driver has completed the described activity.

Upon system activation, the system leaves the quiescent mode, starts searching the environment for parking slots, evaluates the objects detected and generates appropriate feedback to assist the driver.

While the system is active, it may switch its operating mode between “search mode”, “slot found”, “mode selection” and “assisted parking mode” depending on the situation and driver activity.

5.2 Driver interface and information strategy

5.2.1 General information presentation

The system may inform the driver on the current operating mode (e.g. slot search, slot found, assisted parking mode, error mode) and shall provide instructions to the driver which are required for the parking manoeuvre. As a minimum requirement, the system shall give audible information to the driver upon releasing the automatic steering, either when the assisted parking manoeuvre is finished successfully or when it is aborted.

A warning may be issued before the steering wheel starts automatic rotation.

5.2.2 Information in the slot search mode

It is in the responsibility of the vehicle manufacturer to define which kind of information the APS provides to the driver in the slot search mode.

5.2.3 Information during “slot found” until “start of assisted parking”

The driver shall be informed about suitable slots found by the APS.

It is the responsibility of the vehicle manufacturer to define which kind of information is provided to the driver when a suitable slot is found before the assisted parking mode is entered.

5.2.4 Driver request

It is the responsibility of the vehicle manufacturer to define which kind of activities the driver has to do to enable the lateral control of the APS.

The driver may need to confirm the selection of the target parking slot, for example, if more than one possible parking slots are available.

5.2.5 Information during assisted parking

The driver shall be informed when all prerequisites to start manoeuvring into the parking slot are fulfilled and APS switches to the assisted parking mode.

When the vehicle is in the assisted parking mode, the following information or warnings need to be provided to the driver:

- the system shall give audible information to the driver upon releasing the automatic steering;
- in case that APS detects a malfunction (see 4.3.2), the driver shall be informed.

The APS may provide additional information to the driver in the assisted parking mode, such as gear shift instructions or driving speed recommendations.

5.2.6 Information at “end of assisted parking”

The driver shall be informed when APS has finished the parking manoeuvre and stops lateral control of the vehicle (the steering is released upon leaving the assisted parking mode).

5.3 Minimum performance requirements

5.3.1 Performance requirements during slot search mode

When the system is in slot search mode, the minimum system requirements in [Table 1](#) shall be fulfilled.

Table 1 — Minimum requirement for slot search mode

	Type 1 parallel	Type 1 perpendicular
Supported vehicle speed V_{search}	≤ 30 km/h	≤ 20 km/h
Supported lateral clearing distance to parked vehicles	0,5 m ... 1,5 m	0,5 m ... 1,5 m
Driving path	straight	straight
Maximum angle between APS vehicle and connecting line of the bordering vehicles	5°	5°

5.3.2 Performance requirements during assisted parking mode

APSType 1: The supported maximum speed during some portion of the parking manoeuvre shall be at least 5 km/h. It is recommended to limit the speed range during assisted parking and abort the assisted parking mode when the vehicle exceeds this limit. The recommended range for the speed limit is [5 km/h ... 12 km/h]. The vehicle shall follow a trajectory avoiding collisions with objects detected by APS.

5.3.2.1 Performance requirements for the end position APS Type 1 parallel

For the two standard parking situations described in this document the requirements for the end position reached by the APS vehicle at the end of the assisted parking manoeuvre consider the distance D_f , D_r of the front and rear wheel of the vehicle to the kerb and the orientation α to kerb (situation with kerb) or the distance d and the orientation α to the connecting line between the 2 parked vehicles.

NOTE The target distance D_r , D_f (distance rear, front) to the kerb or to the connecting line may be an APS internal parameter depending on the vehicle manufacturer's choice and the current situation. An exact value cannot be defined in this document, but a valid range can be given.

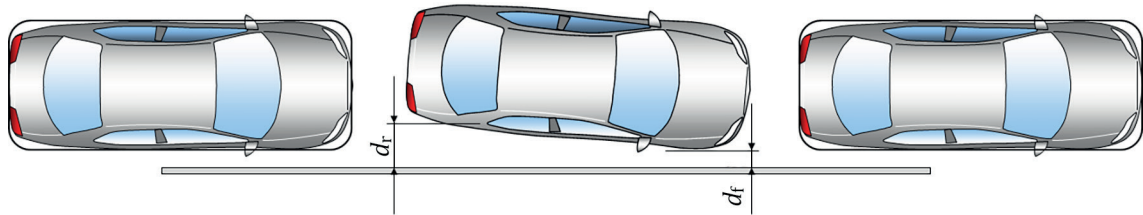

Figure 4 — Definition of D_r and D_f = distance vehicle rear/front to kerb

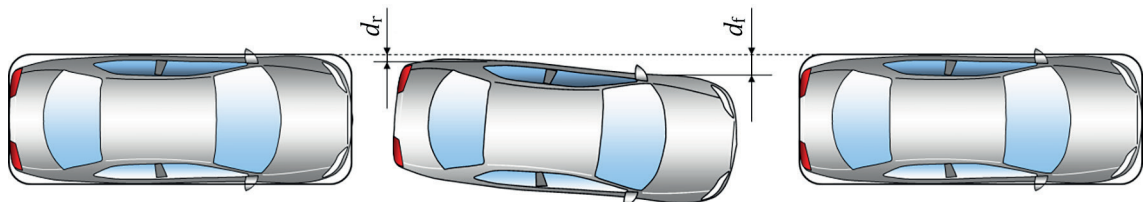
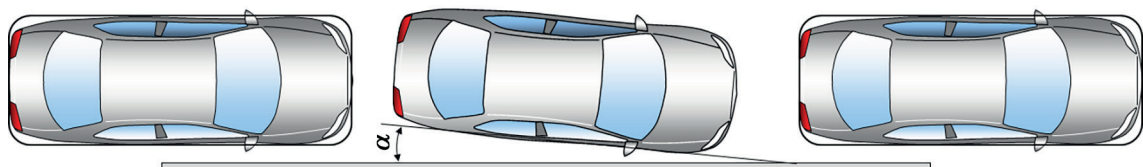
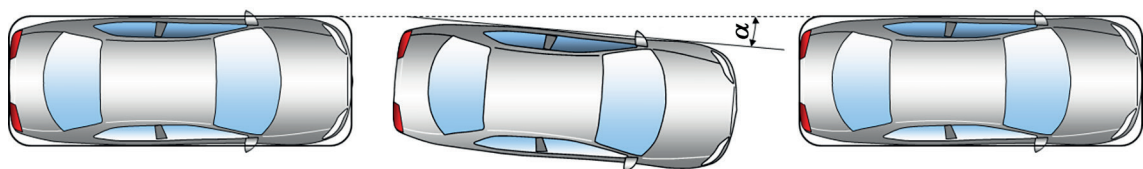

Figure 5 — Definition of D_r and D_f = distance vehicle rear/front to vehicle connecting line



NOTE The angle is positive in this example.

Figure 6 — Definition of α = orientation of vehicle to the kerb



NOTE The angle is positive in this example.

Figure 7 — Definition of α = orientation of vehicle to vehicle connecting line

a) Requirements for the angle

- The angle α to the kerb or vehicle connecting line shall be in the range $-3^\circ \dots +3^\circ$, where 0° is the target value (see [Figures 6](#) and [7](#)).

b) Requirements for the distance from the referenced line

- The distances D_r , D_f from the kerb shall be in the range 0,05 m ... 0,3 m (see [Figure 4](#)) or D_r , D_f from the vehicle connecting line shall be determined by the vehicle manufacturer and depends on the actual width of the APS vehicle (see [Figure 5](#)).

5.3.2.2 Performance requirements for the end position APS Type 1 perpendicular

For the standard parking situations described in this document, the requirements for the end position reached by the APS vehicle at the end of the assisted parking manoeuvre is described by a target area. The target area is limited by four lines (see [Figure 8](#)). Line 1 is parallel to the right flank of the left bordering vehicle at a distance of 0,3 m and line 3 is parallel to the left flank of the right bordering vehicle at a distance of 0,3 m. Lines 2 and 4 are parallel to the front/rear edges of the bordering vehicles at a distance of 0,4 m. As the system does not control the longitudinal movement of the APS vehicle, the driver must stop the vehicle when the system indicates that the assisted parking mode is finished and the target area is reached.

At the end position, the outline of the APS vehicle projected on the ground without regard of the side view mirrors shall be completely within the target area.

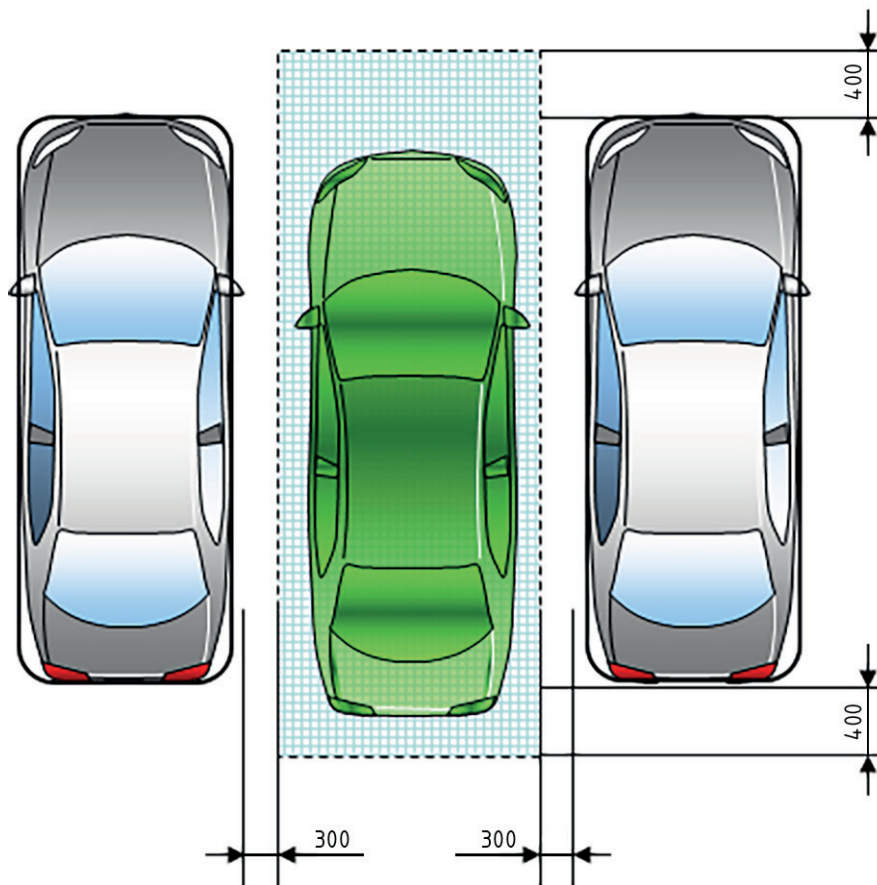

Figure 8 — Definition of β = orientation of vehicle inside the targeted area

Requirements for all situations

- The angle β shall be in the range -3° ... $+3^\circ$, where 0° is the target value.

5.4 Performance test requirements (APS type 1)

5.4.1 Test objects

The test object should represent real world situations and therefore, it is recommended to park between two vehicles of the same type as the test vehicle.

The shape of the reference kerb that shall be used for testing is shown in [Figure 9](#).

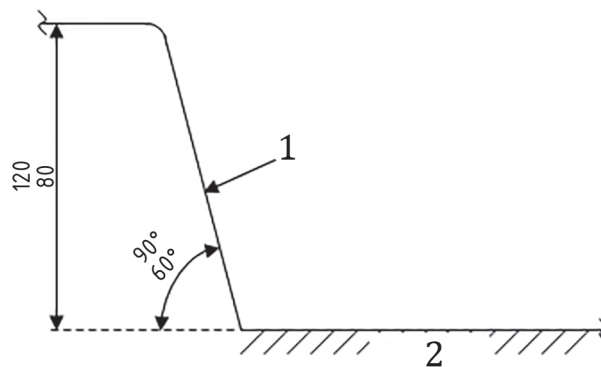

Key

- 1 kerb outward side
- 2 road

Figure 9 — Definition of reference kerb

5.4.2 Ambient conditions — General

The wind speed shall not exceed 5,4 m/s (wind force 3) during testing. Temperature shall be 5 °C to 30 °C and non-precipitating conditions (not raining, sleeting, snowing, etc.). Testing shall be conducted on a flat, dry surface. Walls, auxiliary test equipment and other non-test objects (clutter) shall be removed from the test area in order to eliminate interference caused by their reflections (sonic and/or electromagnetic).

If ambient conditions differ from the above specified conditions, compliance with this document may be tested nonetheless. If the system fails however, the test must be repeated under above specified conditions to prove compliance.

5.4.3 Test criteria

For this document, only the performance of the system regarding assisted parking is considered. Tests, as described in ISO 17386 and ISO 22840, are not in the scope of this document.

The main test criterion for APS is the end position of the vehicle in the parking slot.

5.4.4 Slot search tests

Tests need to be performed with one defined vehicle speed, one lateral clearing distance and angles to parked vehicles (see [Table 2](#)) according to the ranges specified in [5.3.1](#). Ten test trials shall be performed. Parking slot has to be detected at least nine times.

Table 2 — Conditions for slot search test

	Type 1 parallel	Type 1 perpendicular
vehicle speed	27,5 km/h \pm 2,5 km/h	17,5 km/h \pm 2,5 km/h
lateral clearing distance (d_{lcd})	1,20 m \pm 0,30 m	1,00 m \pm 0,30 m
driving path during slot search test	Straight	Straight
Angle between APS vehicle and connecting line of the bordering vehicles during slot search test (θ)	$4^\circ \pm 1^\circ$	$0^\circ \pm 1^\circ$

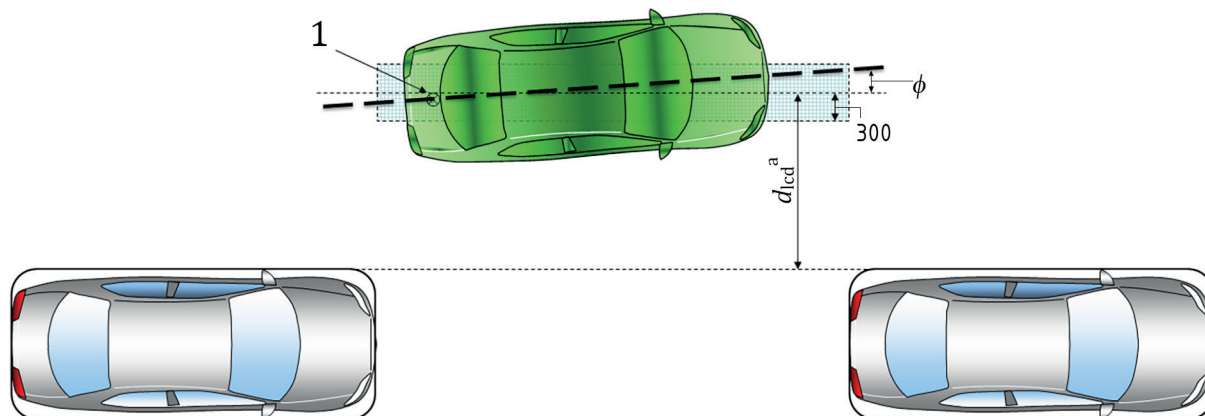

Key

- 1 reference point
- a $\frac{1}{2}$ of vehicle width.

Figure 10 — Illustration on how to perform slot search test with a lateral clearing distance d_{lcd} and angle θ shown for type 1 parallel

Reference point = middle of rear axle has to be inside the area shown in [Figure 10](#).

5.4.5 Test of supported speed during assisted parking

Between the start of the manoeuvre and the diving into the parking slot, a minimum speed peak of 5,5 km/h \pm 0,5 km/h shall be applied.

5.4.6 End position tests

To test the end position of the APS vehicle, 10 test trials shall be conducted in sequence with the same parking slot. Out of the 10 trials, nine have to be successful. A successful trial includes the complete sequence of APS modes (starting from slot search mode).

The distance D_r , D_f and the angle α shall be measured after reaching the end position at each trial. In case of situations with a kerb, d shall be measured from the front wheel to the kerb and from the rear wheel to the kerb.

APS type 1 parallel

- a) Requirements for the angle
 - The mean angle α to the kerb or vehicle connecting line shall be in the range $-3^\circ \dots +3^\circ$.
 - The standard deviation of α shall be not more than $1,5^\circ$.

- b) Requirements for the distance from the referenced line
- The mean distance D_r, D_f from the kerb shall be in the range 0,05 m ... 0,3 m or mean distance D_r, D_f from the vehicle connecting line shall be in the range which determined by the vehicle manufacturer.

The target distance may be chosen in this range by the vehicle manufacturer.

- The standard deviation of D_r, D_f shall be not more than 0,1 m.

APS type 1 perpendicular

Requirement

- The APS vehicle shall be positioned completely within the target area.
- The mean angle β shall be in the range $-3^\circ \dots +3^\circ$.
- The standard deviation of β shall be not more than $1,5^\circ$.

6 Functional and performance requirements APS type 2

6.1 Basic system functionality

6.1.1 Basic function

APS locates the parking slot where the vehicle can park by recognizing the marker(s), such as painted lines on the ground, to determine the target parking slot and calculates a guide route. See [Figure 11](#).

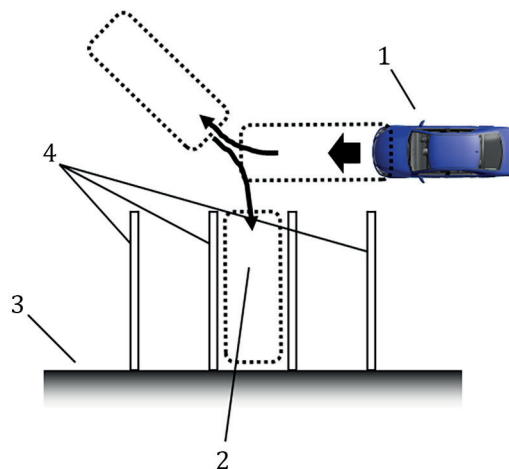

Key

- 1 APS vehicle
- 2 target parking slot
- 3 side of the road, kerb, etc.
- 4 parking slot lines

Figure 11 — Example of perpendicular parking operation

The APS guides the vehicle to the target parking slot by automatically controlling the steering during a parking manoeuvre. Upon completion of control, the vehicle's position in the target parking slot shall fulfil certain accuracy.

This document defines only the area where the APS control is permitted, the target parking slot and the areas of restricted passage shown in [Figures 12](#) and [13](#), without addressing methods for sensing or route guidance or limiting the number of “back and forth” (as in a 3 point turn) used in a turn during parking.

The basic APS function is to assist the driver with lateral control of the vehicle during parking manoeuvres. However, there is a possibility that the scope of automatic control may be expanded in the future.

6.1.2 Geometric requirements

The vehicle should not enter the areas of restricted passage during vehicle control.

[Figures 12](#) and [13](#) show the guideline of the surrounding condition, which needs to be considered in the system design. The APS controlled vehicle is required to stay within the area where APS control is permitted as indicated in the figure. It is also important to let users know how the system assists the parking manoeuvre and its performance limit. The description of how the system works and possible interference with surrounding objects shall at least be stated in the owner’s manual.

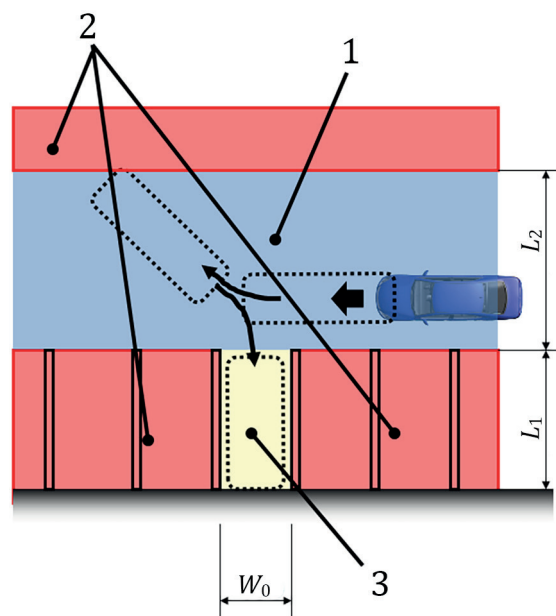

Key

- 1 areas where APS control is permitted
- 2 areas of restricted passage
- 3 target parking slot

W0 2,5 m

L1 6,0 m

L2 7,0 m

For large cars whose width exceeds 1,9 m, “W0” and “L1” can be extended.

The target “W0” for such cars should be “vehicle width + 0,6 m” (0,3 m margin for each side).

The target “L1” for such cars should be “vehicle length + 1,0 m” (0,5 m margin for each end).

Figure 12 — APS required control range for perpendicular parking

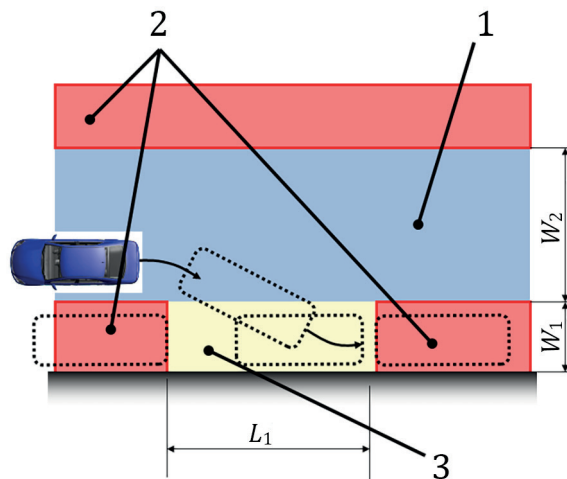

Key

1 area where APS control is permitted

2 areas of restricted passage

3 target parking slot

L_1 $L_v \times 1,4$ m

W_1 2,5 m

W_2 4,5 m or more

NOTE Whereas L_v is the vehicle length.

Figure 13 — APS required control range for parallel parking

6.1.3 APS diagram of operating modes (APS type 2)

[Figure 14](#) shows an example sequence of operating modes and the corresponding information presented to the driver in each operating mode. Also, the driver's activities required to advance the mode and during each mode are described.

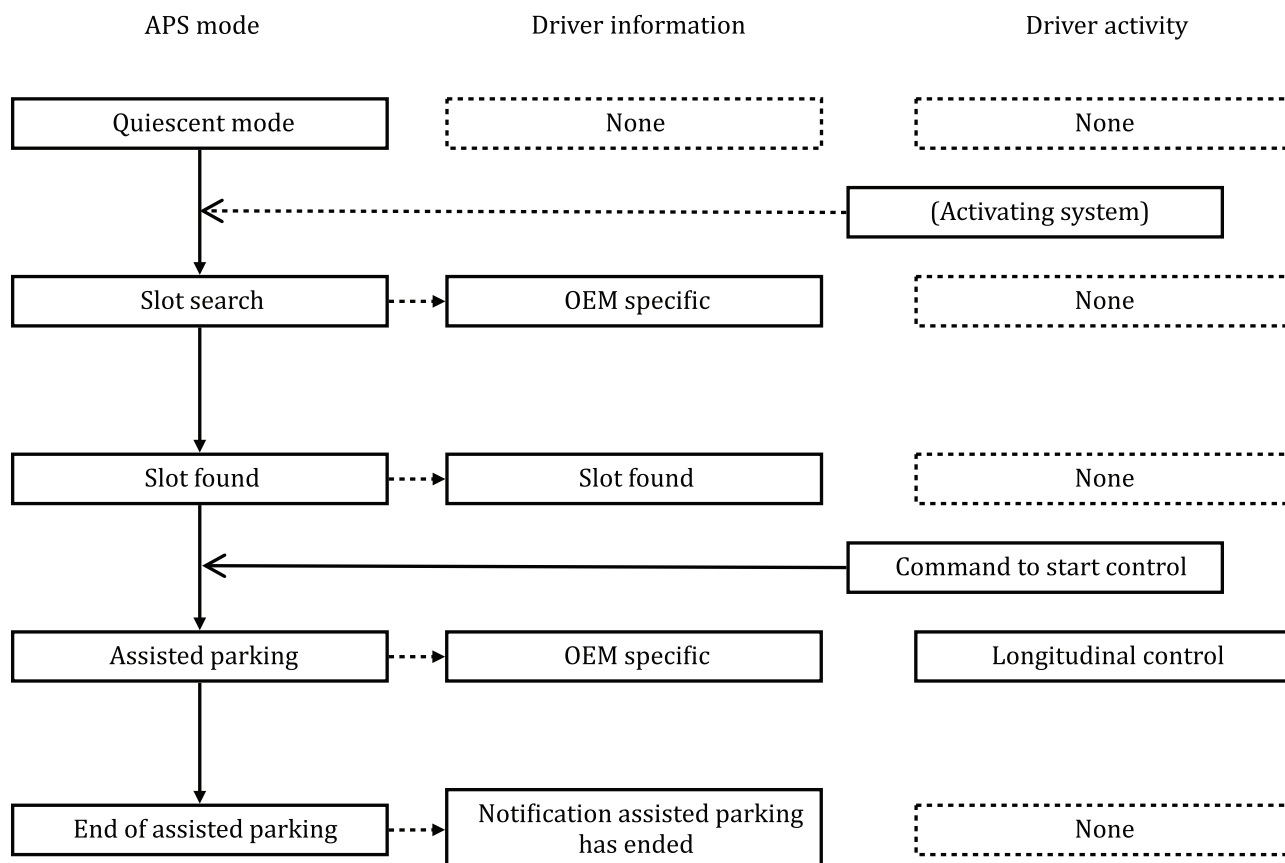

NOTE “Activating system” may be automatic. Information at “slot found” should include the position of the parking slot to be chosen by the driver.

Figure 14 — APS diagram of operating modes (APS type2)

6.2 Driver interface and information strategy

6.2.1 Operation procedure

The timing definition of the “starting APS operation” is when the driver commands the system to start manoeuvring the vehicle towards the targeted parking slot detected by the sensor(s). The vehicle manufacturer should define the requirement for the function of searching the target-parking slot because it depends on the system design such as number, position and performance of the on-board sensor device(s).

For example, the driver needs to move the vehicle manually to the place from where the on-board sensor can capture the target-parking slot in case only single sensor is equipped on the rear end. However, employing extra sensors on the side and front of the vehicle enables the system to start operation earlier by having wider sensing area.

This document defines the requirements for minimally configured system.

6.2.2 Basic operation procedure of APS

The driver launches the system after he/she has brought the vehicle to the place where APS control can be started as instructed by the owner’s manual or such.

The APS informs the driver the target parking position through user interface such as displays.

APS starts manoeuvring the vehicle toward the targeted parking slot triggered by the driver's input such as changing the gear position or depressing the command switch.

The APS should provide the driver essential instructions and necessary warning at an appropriate timing.

The APS shall inform the driver of the end of the APS operation.

An example of typical operation procedure is described in [Annex A](#).

6.3 Minimum performance requirements

6.3.1 Defined parking slot

6.3.1.1 Perpendicular parking

The minimum requirement items for a standard parking slot defined by painted lines and targeted by the system are shown in [Figure 15](#)

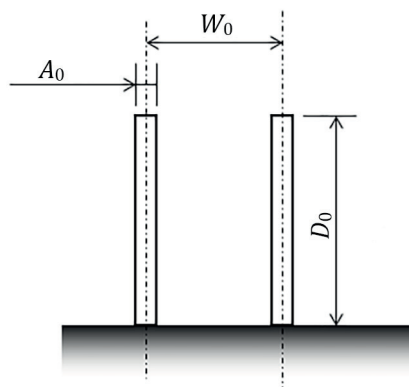

Key

W_0 width of the parking slot opening (= 2,5 m)

D_0 length of parking slot (depth) (= 6,0 m)

A_0 width of parking slot line (= 0,15 m)

For large cars whose width exceeds 1,9 m, " W_0 " can be extended.

The target " W_0 " for such cars should be "vehicle width + 0,6 m" (0,3 m margin for each side).

The minimum requirement for the surface of a parking slot is a flat paved surface.

Figure 15 — Geometry of a defined perpendicular parking slot

6.3.1.2 Parallel parking

The requirement items for a standard parallel parking slot defined by painted lines and targeted by the system are shown in [Figure 16](#).

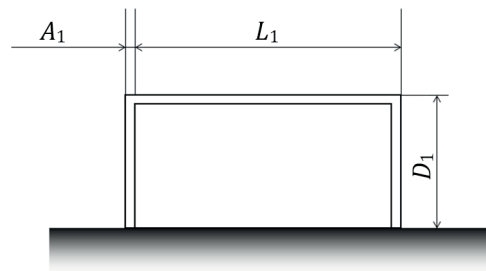

Key

- L1 length of the parking slot (= 7,0 m)
- D1 length of parking slot (depth) (= 2,5 m)
- A1 width of parking slot line (= 0,15 m)

Figure 16 — Geometry of a defined parallel parking slot

6.3.2 Target slot recognition

Upon arrival at the parking assist starting position, the system shall recognize the target parking slot and notify the driver of the results. The method of notification is not addressed in this document.

The minimum illumination requirement for recognition of a parking slot should be 100 lx or less (assuming that indoor parking lots will be used).

It is preferable that the minimum luminance contrast ratio between the parking slot lines and road surface needed for recognition should be 5:1 or more. Definition of the luminance contrast follows.

$$\text{Parking slot line luminance contrast} = (L_{sl} - L_{rs})/L_{rs}$$

where

L_{sl} slot line luminance

L_{rs} road surface luminance

6.3.3 Maximum speed during operation

See [4.3.1](#).

6.3.4 Performance requirements for the end position

6.3.4.1 Perpendicular parking

APS leads the vehicle to the target parking slot. The vehicle shall stay within the parking slot defined by painted lines when it has completed the assistance. Vehicle manufacturer may define the tolerance requirements according to their targeted system performance. System performance is defined as the inclination angle (θ) relative to the parking slot lines and the “deviations” when the parking assist parking is completed. See [Figures 17](#) and [18](#).

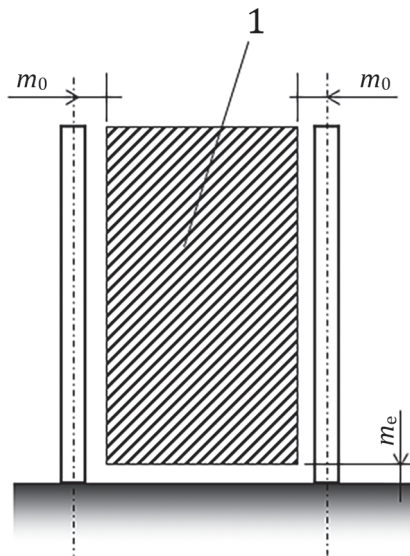

Key

1 target parking area

m_0 0,1 m

m_e 0,1 m

Figure 17 — Definition of target area for end position of APS type 2 perpendicular

APS vehicle shall be placed within the target parking area defined by [Figure 17](#). Maximum tolerance of angular alignment to the parking slot defining lines shall be less than 3° (see [Figure 18](#)).

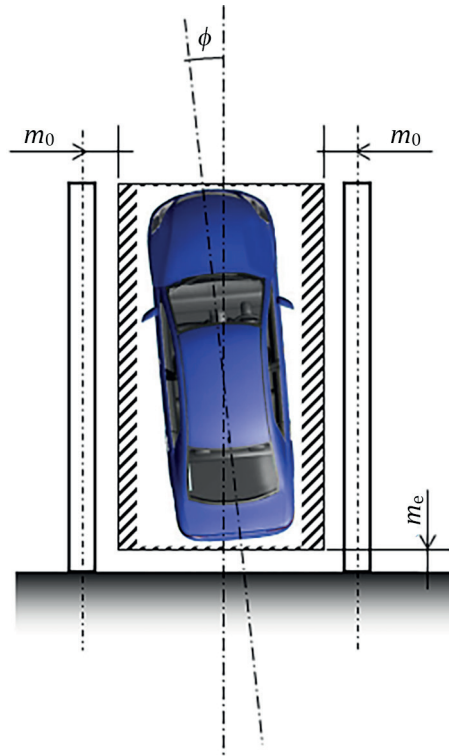

Key

m_0 0,1 m

m_e 0,1 m

$-3,0 \leq \theta \leq 3,0^\circ$

Figure 18 — Definition of border-line of APS type 2 perpendicular

6.3.4.2 Parallel parking

System performance is defined as the angle (θ) relative to the road edge and the “margins” when the parking assist parking is completed (see [Figure 19](#)).

Margins (M_f , M_r) are the shortest distances from the points of outermost tire contact with the ground to the outer edge of the parking slot line. M_e is the shortest distance between the rearmost body and outer edge of the line.

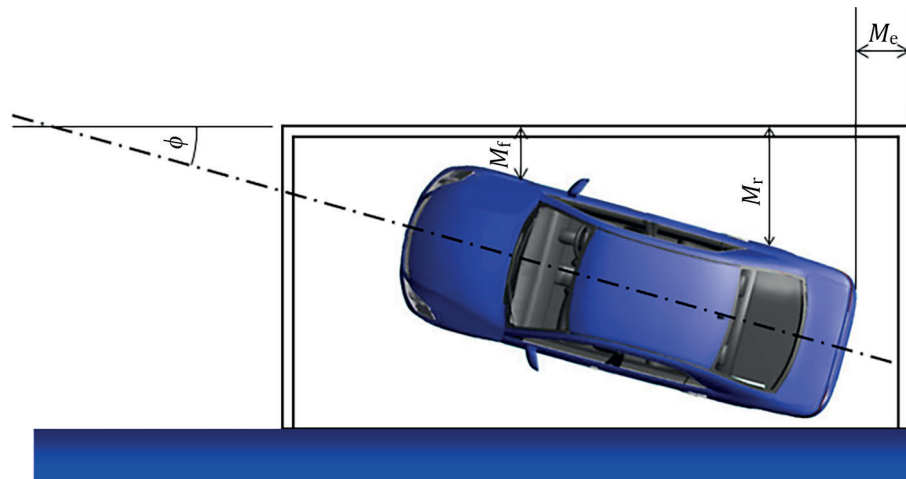

NOTE 1 Parking slot line width: 0,15 m.

NOTE 2 Performance target: $\theta = 0^\circ$, $M_f > 0,15$ m, $M_r > 0,15$ m, $M_e > 0,8$ m.

NOTE 3 Recommended tolerance: $-3,0 \leq \theta \leq 3,0^\circ$, $M_f > 0$ m, $M_r > 0$ m, $M_e > 0$ m.

Figure 19 — Definition of border line of APS type 2 parallel

6.4 Performance test requirements

6.4.1 Performance test conditions

The illumination for the target parking slot should be 100 lx or more.

The brightness contrast ratio between the painted lines and the surface should be 5:1 or more.

6.4.2 Parking slot recognition test

Parking slots should be on a flat, uniform and (asphalt or concrete) paved surface.

The typical test parking slot dimensions are defined in [Figure 17](#) for perpendicular and [Figure 18](#) for parallel parking.

6.4.2.1 Perpendicular parking

Parking slot recognition performance should be tested in a parking slot similar to the standard conditions shown [Figure 17](#).

Typical dimensions of the test target are defined in [Figure 20](#) from which vehicle manufacturers may select the vehicle's relative position for the test.

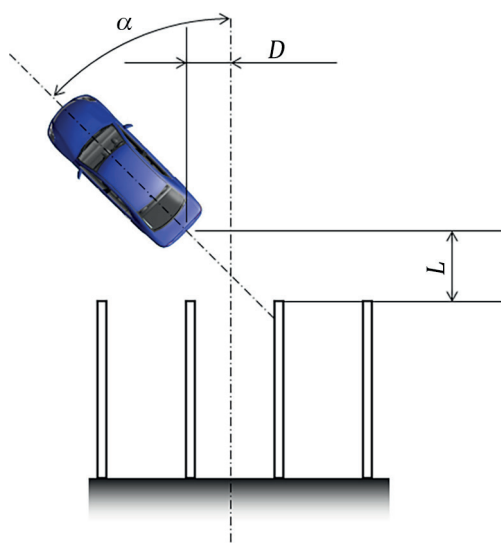

Key

- α $45,0^\circ \pm 5,0^\circ$
- L $1,8 \text{ m} \pm 0,5 \text{ m}$
- D $1,0 \text{ m} \pm 0,5 \text{ m}$

Figure 20 — Definition of test site APS type 2 perpendicular

6.4.2.2 Parallel parking

Parking slot recognition performance should be tested in a parking slot similar to the standard conditions shown in [Figure 21](#).

Typical dimensions of the test target are defined in [Figure 21](#) from which vehicle manufacturers may select the vehicle's relative position for the test.

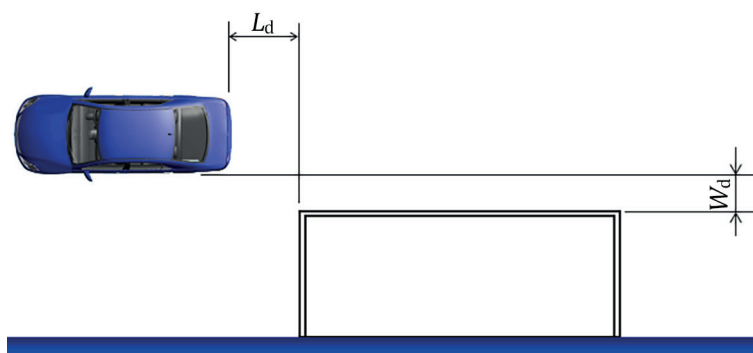

Key

- Ld $L_v \times 0,5 \text{ m} \pm 0,5 \text{ m}$
- Wd $V_w \times 0,5 \text{ m} \pm 0,5 \text{ m}$

Where L_v is the vehicle length and V_w is the vehicle width.

Figure 21 — Definition of test site APS type 2 parallel

6.4.3 Environmental conditions — General

Non-precipitating conditions (not raining, sleeting, snowing, etc.). Testing shall be conducted on a flat, dry surface. Walls, auxiliary test equipment and other non-test objects (clutter) shall be removed from the test area in order to eliminate interference caused by their reflections (sonic and/or electromagnetic). No extra marking on the surface, except the parking slot defining lines, is allowed and any objects, which may interfere with the image recognition process, shall be removed.

6.4.4 Test criteria

For this document, only the performance of the system regarding assisted parking is considered. The main test criterion for APS is the end position of the vehicle in the parking slot.

6.4.5 End position tests

Evaluate the vehicle position when parking assist is completed.

6.4.5.1 Perpendicular parking

Measure the “angle (θ)” relative to the centreline between the parking slot lines, the lateral “margins” (M_{fl} , M_{fr} , M_{rl} , M_{rr}) from the centre of the parking slot line and the longitudinal margin (M_e) from the rearmost parking slot.

The vehicle reference points for the lateral margins are the outermost tire contact points with the ground whereas the rearmost part of the vehicle body is for the longitudinal margin.

Criteria: $-3,0 \leq \theta \leq 3,0^\circ$, $M_{fl} > m_0$, $M_{fr} > m_0$, $M_{rl} > m_0$, $M_{rr} > m_0$ ($m_0 = 0,1 \text{ m}$), $M_e > m_e$ ($m_e = 0,1 \text{ m}$)

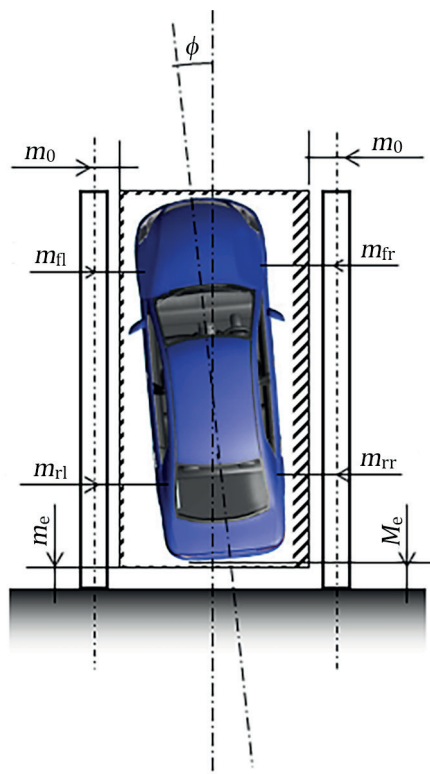

Figure 22 — Definition of end position tests APS type 2 perpendicular

6.4.5.2 Parallel parking

The vehicle shall be within the parking slot lines and not stay over the lines. Measure the “angle (θ)” relative to the outer-line of the slot and measure the “deviations” (M_f , M_r , M_e) from the corresponding lines of the parking slot line as shown in [Figure 23](#).

Criteria: $-3,0 \leq \theta \leq 3,0^\circ$, $M_f > 0$ m, $M_r > 0$ m, $M_e > 0$ m

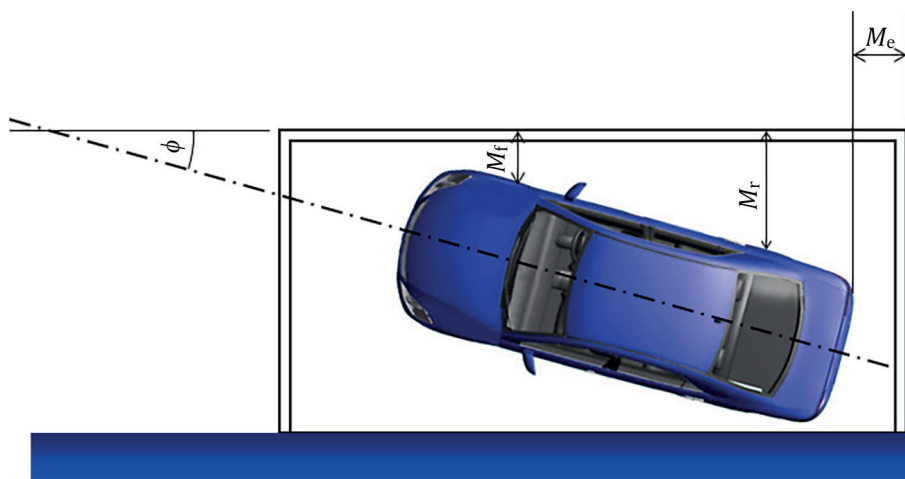

Figure 23 — Definition of end position tests APS type 2 parallel

Annex A (informative)

Example of APS operation sequence

The APS function is executed in the following subsequent steps.

a) Vehicle placement

- The driver should move the vehicle manually to the position where the sensor can capture the parking slot defined by markings such as painted lines. (① → ②).

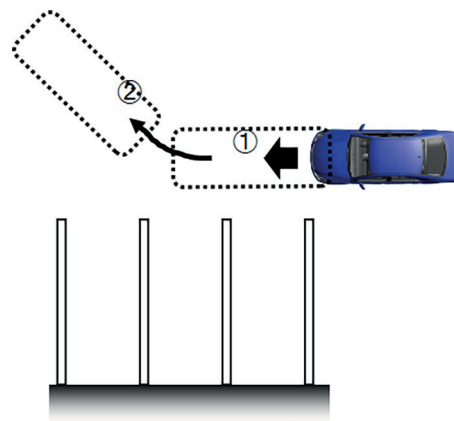

Figure A.1 — Vehicle placement for perpendicular parking

b) Turn the main switch ON

- Main switch: the system should have a main switch for operation by the driver. After the driver turns the main switch ON, the sequence after the selection of parking assist mode should be followed.
- When the main switch is turned OFF, all control should be cancelled.

c) Recognizing parking slot

- The APS recognizes slots where the vehicle can be parked, for example, from slot lines in the sensor image and overlay a grid (frame) on the same sensor image.

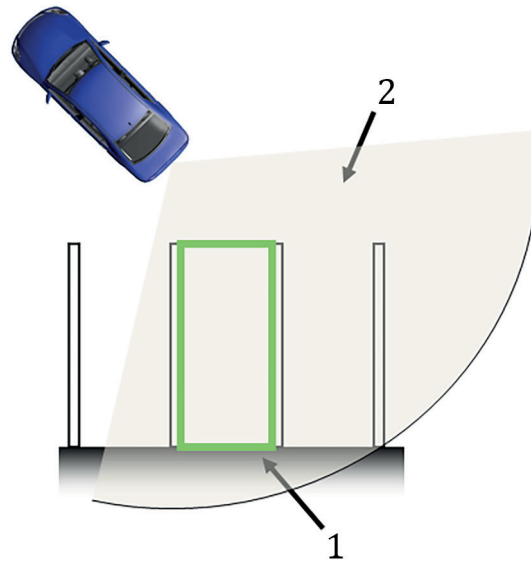

Key

- 1 recognized target parking slot
- 2 sensor FOV

Figure A.2 — Recognizing target slot for perpendicular parking

The method of overlaid display, such as a top view from above the vehicle or direct portrayal of the sensor image, depends on the manufacturer's design and there are no such restrictions.

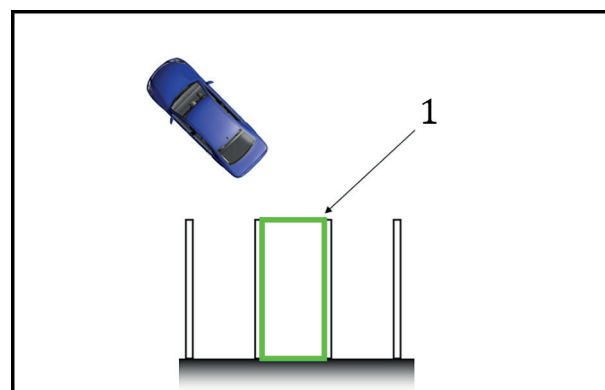

Key

- 1 recognized target parking slot

Figure A.3 — Example of top view

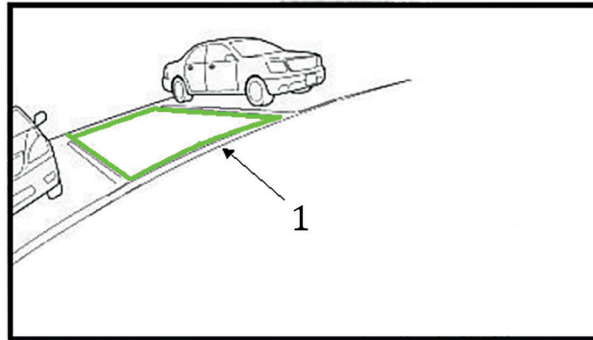

Key

- 1 recognized target parking slot

Figure A.4 — Example of sensor image

d) Driver confirmation of the target-parking slot

- The system should be able to inform the driver about suitable parking slots found.
- The driver should be able to confirm the start of control before the vehicle moves toward a target-parking slot detected by the system or selected by the driver.

e) Assisted parking

- When the driver decides to park into the suitable parking slot found and stops the vehicle, the APS should assist the driver with advice and by actuating the steering during the parking manoeuvre.
- A warning may be issued in advance to remind the driver to be careful before the steering wheel starts to rotate by automatic control.
- The ability of the system to support the parking manoeuvre will depend on the actual starting position of the APS vehicle relative to the parking slot. The limitations of the permissible starting positions should be described in the owner's manual of the vehicle.
- The actuation of the steering should not start before the vehicle stands still.
- The driver should be able to take over lateral control of the APS vehicle at any time. In this case, the APS should terminate the automated actuation of the steering immediately.

f) End of assisted parking

- The driver should be informed when the parking manoeuvre is finished or aborted.

Bibliography

- [1] ISO 2575, *Road vehicles — Symbols for controls, indicators and tell-tales*
- [2] ISO 15006, *Road vehicles — Ergonomic aspects of transport information and control systems — Specifications for in-vehicle auditory presentation*
- [3] ISO 15008, *Road vehicles — Ergonomic aspects of transport information and control systems — Specifications and compliance procedures for in-vehicle visual presentation*
- [4] ISO 16750 (all parts), *Road vehicles — Environmental conditions and testing for electrical and electronic equipment*
- [5] ISO 17386, *Transport information and control systems — Manoeuvring Aids for Low Speed Operation (MALSO) — Performance requirements and test procedures*
- [6] ISO 22840, *Intelligent transport systems — Devices to aid reverse manoeuvres — Extended-range backing aid systems (ERBA)*

British Standards Institution (BSI)

BSI is the national body responsible for preparing British Standards and other standards-related publications, information and services.

BSI is incorporated by Royal Charter. British Standards and other standardization products are published by BSI Standards Limited.

About us

We bring together business, industry, government, consumers, innovators and others to shape their combined experience and expertise into standards-based solutions.

The knowledge embodied in our standards has been carefully assembled in a dependable format and refined through our open consultation process. Organizations of all sizes and across all sectors choose standards to help them achieve their goals.

Information on standards

We can provide you with the knowledge that your organization needs to succeed. Find out more about British Standards by visiting our website at bsigroup.com/standards or contacting our Customer Services team or Knowledge Centre.

Buying standards

You can buy and download PDF versions of BSI publications, including British and adopted European and international standards, through our website at bsigroup.com/shop, where hard copies can also be purchased.

If you need international and foreign standards from other Standards Development Organizations, hard copies can be ordered from our Customer Services team.

Copyright in BSI publications

All the content in BSI publications, including British Standards, is the property of and copyrighted by BSI or some person or entity that owns copyright in the information used (such as the international standardization bodies) and has formally licensed such information to BSI for commercial publication and use.

Save for the provisions below, you may not transfer, share or disseminate any portion of the standard to any other person. You may not adapt, distribute, commercially exploit, or publicly display the standard or any portion thereof in any manner whatsoever without BSI's prior written consent.

Storing and using standards

Standards purchased in soft copy format:

- A British Standard purchased in soft copy format is licensed to a sole named user for personal or internal company use only.
- The standard may be stored on more than 1 device provided that it is accessible by the sole named user only and that only 1 copy is accessed at any one time.
- A single paper copy may be printed for personal or internal company use only.

Standards purchased in hard copy format:

- A British Standard purchased in hard copy format is for personal or internal company use only.
- It may not be further reproduced – in any format – to create an additional copy. This includes scanning of the document.

If you need more than 1 copy of the document, or if you wish to share the document on an internal network, you can save money by choosing a subscription product (see 'Subscriptions').

Reproducing extracts

For permission to reproduce content from BSI publications contact the BSI Copyright & Licensing team.

Subscriptions

Our range of subscription services are designed to make using standards easier for you. For further information on our subscription products go to bsigroup.com/subscriptions.

With **British Standards Online (BSOL)** you'll have instant access to over 55,000 British and adopted European and international standards from your desktop. It's available 24/7 and is refreshed daily so you'll always be up to date.

You can keep in touch with standards developments and receive substantial discounts on the purchase price of standards, both in single copy and subscription format, by becoming a **BSI Subscribing Member**.

PLUS is an updating service exclusive to BSI Subscribing Members. You will automatically receive the latest hard copy of your standards when they're revised or replaced.

To find out more about becoming a BSI Subscribing Member and the benefits of membership, please visit bsigroup.com/shop.

With a **Multi-User Network Licence (MUNL)** you are able to host standards publications on your intranet. Licences can cover as few or as many users as you wish. With updates supplied as soon as they're available, you can be sure your documentation is current. For further information, email subscriptions@bsigroup.com.

Revisions

Our British Standards and other publications are updated by amendment or revision.

We continually improve the quality of our products and services to benefit your business. If you find an inaccuracy or ambiguity within a British Standard or other BSI publication please inform the Knowledge Centre.

Useful Contacts

Customer Services

Tel: +44 345 086 9001

Email (orders): orders@bsigroup.com

Email (enquiries): cservices@bsigroup.com

Subscriptions

Tel: +44 345 086 9001

Email: subscriptions@bsigroup.com

Knowledge Centre

Tel: +44 20 8996 7004

Email: knowledgecentre@bsigroup.com

Copyright & Licensing

Tel: +44 20 8996 7070

Email: copyright@bsigroup.com

BSI Group Headquarters

389 Chiswick High Road London W4 4AL UK