

BS ISO 16571:2014



BSI Standards Publication

Systems for evacuation of plume generated by medical devices

bsi.

...making excellence a habit.™

National foreword

This British Standard is the UK implementation of ISO 16571:2014.

The UK participation in its preparation was entrusted to Technical Committee CH/121/6, Medical gas supply systems.

A list of organizations represented on this committee can be obtained on request to its secretary.

This publication does not purport to include all the necessary provisions of a contract. Users are responsible for its correct application.

© The British Standards Institution 2014.
Published by BSI Standards Limited 2014

ISBN 978 0 580 74675 8
ICS 11.040.10

Compliance with a British Standard cannot confer immunity from legal obligations.

This British Standard was published under the authority of the Standards Policy and Strategy Committee on 31 May 2014.

Amendments/corrigenda issued since publication

Date	Text affected
------	---------------

INTERNATIONAL
STANDARD

ISO
16571

First edition
2014-03-15

**Systems for evacuation of plume
generated by medical devices**

*Systèmes de gaz médicaux — Systemes d'évacuation des effluents
gazeux générés par l'utilisation de dispositifs médicaux*



Reference number
ISO 16571:2014(E)



COPYRIGHT PROTECTED DOCUMENT

© ISO 2014

All rights reserved. Unless otherwise specified, no part of this publication may be reproduced or utilized otherwise in any form or by any means, electronic or mechanical, including photocopying, or posting on the internet or an intranet, without prior written permission. Permission can be requested from either ISO at the address below or ISO's member body in the country of the requester.

ISO copyright office
Case postale 56 • CH-1211 Geneva 20
Tel. + 41 22 749 01 11
Fax + 41 22 749 09 47
E-mail copyright@iso.org
Web www.iso.org

Published in Switzerland

Contents

Page

Foreword	v
Introduction	vi
1 Scope	1
2 Normative references	1
3 Terms and definitions	2
4 General requirements	5
5 Design requirements	6
5.1 Components.....	6
5.2 Connectors.....	6
5.3 Supply system for central plume evacuation.....	8
6 Indicating systems	8
7 Plume extraction system pipeline	8
7.1 Mechanical integrity.....	8
7.2 Pressures and flows.....	8
7.3 Shut-off valves.....	9
8 System components	9
8.1 Capture device.....	9
8.2 Transfer tubing — Kinking.....	10
8.3 Filtration system.....	10
8.4 Flow-generating device.....	10
8.5 Exhaust system.....	10
8.6 Control system.....	11
8.7 Pipelines, tubing, and other components.....	11
9 Terminal units	11
10 Marking and colour coding	12
10.1 Marking.....	12
10.2 Colour coding.....	12
11 Pipeline installation	12
12 Testing, commissioning, and certification of the PES	12
12.1 General requirements for tests.....	12
12.2 Noise testing.....	12
12.3 Tests, inspections, and checks of a fixed (local stationary or central) PES.....	13
12.4 Tests, inspections, and checks of portable and mobile PES.....	14
13 Information to be supplied by the manufacturer	15
13.1 General.....	15
13.2 Instructions for use.....	15
13.3 Operational management information.....	16
Annex A (informative) Types of plume evacuation systems	17
Annex B (informative) Healthcare facility policies and procedures	23
Annex C (informative) Typical plume capture devices and transfer tubings	26
Annex D (informative) Risk management checklist	27
Annex E (informative) Operational management	28
Annex F (informative) Rationale	29
Annex G (informative) Example of procedure for testing and commissioning for a central system	30

Annex H (informative) Guidelines for flow-generating devices consisting of fans or blowers	32
Bibliography	33

Foreword

ISO (the International Organization for Standardization) is a worldwide federation of national standards bodies (ISO member bodies). The work of preparing International Standards is normally carried out through ISO technical committees. Each member body interested in a subject for which a technical committee has been established has the right to be represented on that committee. International organizations, governmental and non-governmental, in liaison with ISO, also take part in the work. ISO collaborates closely with the International Electrotechnical Commission (IEC) on all matters of electrotechnical standardization.

The procedures used to develop this document and those intended for its further maintenance are described in the ISO/IEC Directives, Part 1. In particular the different approval criteria needed for the different types of ISO documents should be noted. This document was drafted in accordance with the editorial rules of the ISO/IEC Directives, Part 2 (see www.iso.org/directives).

Attention is drawn to the possibility that some of the elements of this document may be the subject of patent rights. ISO shall not be held responsible for identifying any or all such patent rights. Details of any patent rights identified during the development of the document will be in the Introduction and/or on the ISO list of patent declarations received (see www.iso.org/patents).

Any trade name used in this document is information given for the convenience of users and does not constitute an endorsement.

For an explanation on the meaning of ISO specific terms and expressions related to conformity assessment, as well as information about ISO's adherence to the WTO principles in the Technical Barriers to Trade (TBT) see the following URL: Foreword - Supplementary information

The committee responsible for this document is ISO/TC 121, *Anaesthetic and respiratory equipment*, Subcommittee SC 6, *Medical gas systems*.

Introduction

Certain surgical, diagnostic, and therapeutic techniques can generate noxious airborne contaminants (plume) as by-products, particularly from procedures that include the cutting, ablation, cauterization, or mechanical manipulation of target tissue by energy-based devices such as lasers, electrosurgical generators, broadband light sources, ultrasonic instruments, etc. or mechanical surgical tools such as bone saws, high speed drills, and reamers. New technologies in cutting and sealing can result in less plume generation (see Reference [85]) but plume remains a hazard. Energy-based contact with articles such as tubing, swabs, and skin preparation solutions will produce additional chemicals. This International Standard was developed in response to awareness of the potential hazards to patients and staff of plume generated by these techniques in healthcare settings.

Plume can contain a variety of contaminants: viable bacteria (including multi-resistant strains), viruses, cellular debris (including DNA), airborne chemicals, particulates, ultrafine particles, aerosols, gases, vapours, and fumes (including fumes from metals). *In vitro* studies of bacterial and viral contamination have found viable *Escherichia coli*, *Staphylococcus aureus*, human papillomavirus (HPV), hepatitis viruses (HVB, HVC), and human immunodeficiency virus (HIV) in plume. The gases in plume can include toxic substances such as benzene, formaldehyde, and hydrogen cyanide. Plume can also contain aerosolized blood (plasma, cells, or fragments of cells) and blood-borne pathogens.

Plume thus poses a hazard to exposed persons. It can transmit infection, or have mutagenic or carcinogenic effects. Plume can also cause irritation of the mucous membranes, eyes, respiratory system, and skin. Additionally, plume reduces the clinician's ability to clearly see the operative field, resulting in unsafe operating conditions.

This International Standard specifies requirements for systems for evacuation of plume generated in healthcare facilities. It is intended for those persons involved in the design, construction, inspection, and operation of healthcare facilities. Those persons involved in the design, manufacture, installation, testing, and use of equipment and components for plume evacuation systems should also be aware of the contents of this International Standard.

This International Standard seeks to ensure that plume generated in healthcare facilities is not evacuated through the medical vacuum or anaesthetic gas scavenging systems. For this reason, type-specific components are specified for terminal units and for other connectors which are intended to be used by the operator.

The objectives of this International Standard are to ensure the following:

- a) non-interchangeability with other products or pipeline systems by design;
- b) continuous extraction at specified pressures and flows;
- c) use of suitable materials for all components of the system;
- d) provision of monitoring indicators and alarm systems;
- e) correct rating of filtration systems;
- f) correct indication of filter life;
- g) correct marking and labelling;
- h) electrical and environmental testing;
- i) correct installation;
- j) testing, commissioning, and certification;
- k) provision of guidance on operational management;
- l) appropriate manufacturer's instructions for use, training, service, and maintenance.

[Annex F](#) contains rationale statements for some of the requirements of this International Standard. It is included to provide additional insight into the reasoning that led to the requirements and recommendations that have been incorporated into this International Standard. The clauses and subclauses marked with * after their number have corresponding rationale contained in [Annex F](#). It is considered that knowledge of the reasons for the requirements will not only facilitate the proper application of this International Standard, but will expedite any subsequent revisions.

Systems for evacuation of plume generated by medical devices

1 Scope

1.1 This International Standard specifies requirements and guidelines for the design, manufacture, installation, function, performance, maintenance, servicing, documentation, testing, and commissioning of equipment for evacuation of plume generated by medical devices.

NOTE A plume evacuation system (PES) can be a functionally independent component of a medical device that has other functions.

1.2 This International Standard is applicable to

- a) portable and mobile plume evacuation systems,
- b) local stationary plume evacuation systems,
- c) dedicated central pipeline systems for plume evacuation systems, and
- d) plume evacuation systems integrated into other equipment (e.g. laser equipment).

1.3* This International Standard does not apply to active and passive devices used to evacuate plume generated during invasive (e.g. laparoscopic or endoscopic) procedures.

1.4 This International Standard does not apply to the following:

- a) anaesthetic gas scavenging systems (AGSSs) which are covered in ISO 7396-2;
- b) medical vacuum systems which are covered in ISO 7396-1;
- c) heating, ventilation, and air-conditioning (HVAC) systems;
- d) aspects of laser safety other than airborne contamination;

NOTE Some other aspects of laser safety are covered by IEC 60825 (see Reference [Z]).

- e) aspects of electrosurgery, electrocautery, and mechanical surgical tools other than airborne contamination produced by such equipment resulting from interaction with tissue or materials.

2 Normative references

The following documents, in whole or in part, are normatively referenced in this document and are indispensable for its application. For dated references, only the edition cited applies. For undated references, the latest edition of the referenced document (including any amendments) applies.

ISO 3744:2010, *Acoustics — Determination of sound power levels and sound energy levels of noise sources using sound pressure — Engineering methods for an essentially free field over a reflecting plane*

ISO 5359, *Low-pressure hose assemblies for use with medical gases*

ISO 7396-1:2007, *Medical gas pipeline systems — Part 1: Pipelines for compressed medical gases and vacuum*

ISO 11197, *Medical supply units*

ISO 14971, *Medical devices — Application of risk management to medical devices*

IEC 60601-1, *Medical electrical equipment — Part 1: General requirements for basic safety and essential performance*

IEC 61672-1, *Electroacoustics — Sound level meters — Part 1: Specifications*

IEC 62366, *Medical devices — Application of usability engineering to medical devices*

EN 1041, *Information supplied by the manufacturer of medical devices*

EN 1822-1, *High efficiency air filters (HEPA and ULPA) — Classification, performance testing, marking*

EN 13348, *Copper and copper alloys — Seamless, round copper tubes for medical gases or vacuum*

3 Terms and definitions

For the purposes of this document, the following terms and definitions apply.

3.1 adsorber

device that removes volatile organic compounds and odours from a gas stream

EXAMPLE Activated carbon filter.

3.2 capture device

hose, tube, funnel, or other accessory that provides the inlet to the plume evacuation system at the site of plume generation

3.3 central plume evacuation system

permanently installed PES which includes a supply system, a pipeline system, and terminal unit(s), and that conveys the plume to the outside of the building

3.4 diversity factor

factor which represents the maximum proportion of terminal units in a defined clinical area which will be used at the same time, at flow rates defined in agreement with the management of the healthcare facility and according to this International Standard

3.5 electrocautery

surgical technique that uses an electrically heated device to cut, ablate, or coagulate tissue for therapeutic purposes

Note 1 to entry: Electrosurgery is also known as high frequency (HF) surgery or surgical diathermy.

3.6 electrosurgery

surgical technique that uses a radiofrequency electric current passing through the patient to cut, ablate, or coagulate tissue for therapeutic purposes

3.7 flow-generating device

part of a plume evacuation system that provides flow and vacuum for evacuating plume

3.8 junction point

connection point between the inlet tubing to the flow-generating device and the PES pipeline

Note 1 to entry: See [Figure A.3](#).

3.9

local stationary plume evacuation system

permanently installed PES that includes a flow-generating device and terminal unit and that vents the filtered plume inside the room

3.10

manufacturer

natural or legal person with responsibility for the design, manufacture, packaging, and labelling of a device before it is placed on the market under his own name, regardless of whether these operations are carried out by that person himself or on his behalf by a third party

3.11

medical device

any instrument, apparatus, appliance, software, material, or other article, whether used alone or in combination, including the software intended by its manufacturer to be used specifically for diagnostic and/or therapeutic purposes and necessary for its proper application, and intended by the manufacturer to be used for human beings for the purpose of

- diagnosis, prevention, monitoring, treatment, or alleviation of disease,
- diagnosis, monitoring, treatment, alleviation of, or compensation for an injury or handicap,
- investigation, replacement, or modification of the anatomy or of a physiological process, and
- control of conception,

and which does not achieve its principal intended action in or on the human body by pharmacological, immunological, or metabolic means, but which can be assisted in its function by such means

3.12

medical supply unit

permanently installed medical electrical equipment intended to supply electric power, lighting, and/or medical gases and/or liquids, plume evacuation systems, and anaesthetic gas scavenging systems to medical areas of a healthcare facility

Note 1 to entry: Medical supply units can include medical electrical equipment or medical electrical systems or parts thereof. Medical supply units can also consist of modular sections for electrical supply, lighting for therapy or illumination, communication, supply of medical gases and liquids, plume evacuation systems, and anaesthetic gas scavenging systems. Some typical examples of medical supply units are bed head services modules, ceiling pendants, beams, booms, columns, pillars, cabinetry, concealed compartments on or in a wall, and prefabricated walls.

Note 2 to entry: Detailed information about medical supply units can be found in ISO 11197.

3.13

mobile

referring to transportable equipment intended to be moved from one location to another while supported by its own wheels or equivalent means

3.14

pipeline system

portion of a central PES between the terminal unit(s) and the supply system

3.15

plume

noxious airborne contaminants generated as by-products, particularly by procedures that rely on the ablation, cauterization, mechanical manipulation, or thermal desiccation of target tissue by devices such as lasers, electrosurgical or electrocautery devices, broadband light sources, ultrasonic instruments, or surgical tools such as bone saws, high speed drills, and reamers

Note 1 to entry: Plume can include visible or invisible aerosol particles, smoke, or gases.

3.16
plume evacuation system
PES

device for capturing, transporting, and filtering plume and exhausting the filtered product

Note 1 to entry: Plume evacuation systems can also be called smoke evacuators, laser plume evacuators, plume scavengers, and local exhaust ventilators (LEVs).

Note 2 to entry: Diagrams of typical PESs are found in [Annex A](#).

3.17
portable

referring to transportable equipment intended to be moved from one location to another while being carried by one or more persons

3.18
pre-filter

device intended to protect filtration equipment from damage by preventing the intake of large particles and/or moisture

3.19
single fault condition

condition in which a single means for protection against a safety hazard in equipment is defective or a single external abnormal condition is present

3.20
single use

referring to a product intended to be used once and then discarded

3.21
source of supply

portion of the supply system with associated control equipment which supplies the pipeline system

[SOURCE: ISO 7396-1]

3.22
supply system

assembly which supplies the pipeline system and which includes all sources of supply

[SOURCE: ISO 7396-1]

3.23
system design flow

flow calculated from the maximum flow requirement of the healthcare facility and corrected by the diversity factor(s)

[SOURCE: ISO 7396-1]

3.25
terminal unit

inlet assembly in a plume evacuation system at which the operator makes connections and disconnections

Note 1 to entry: See [Figure 1](#).

3.26
transfer tubing

tubing between the capture device and the filtration system

3.27

transportable

referring to equipment that is intended to be moved from one place to another, whether or not connected to a supply and without any appreciable restriction of range

EXAMPLE Mobile equipment and portable equipment.

3.28

ultra-low penetration (or particulate) air (ULPA) filter

filter with an overall particulate efficiency of not less than 99,999 5 % as determined by EN 1822-1

3.29

ultrasonic surgical device

surgical device that utilizes high frequency vibration to enable hemostatic cutting or cautery, created by thermal effects, coupled with fragmentation of tissue

4 General requirements

All pressures in this International Standard are gauge pressures (i.e. relative to local atmospheric pressure) and are measured in kPa.

4.1 PESs shall, when installed, extended, modified, commissioned, operated, and maintained in accordance with the instructions of the manufacturer, present no risks that are not reduced to an acceptable level using risk management procedures in accordance with ISO 14971 and which are connected with their intended application, in normal condition and in single fault condition.

NOTE 1 A situation in which a fault is not detected is considered a normal condition. Fault conditions/hazardous situations can remain undetected over a period of time and as a consequence can lead to an unacceptable risk. In that case, a subsequent detected fault condition needs to be considered as a single fault condition. Specific risk control measures need to be determined within the risk management process to deal with such situations.

NOTE 2 Typical safety hazards are listed in [Annex D](#).

4.2 The manufacturer can use type tests different from those described in this International Standard, if an equivalent degree of compliance can be demonstrated. However, in the event of dispute, the test arrangements and methods described in this International Standard shall be used as the reference methods.

4.3 When used in accordance with the manufacturer's instructions, the efficiency of plume removal shall be at least 90 %.

Evidence shall be provided by the manufacturer.

4.4* A PES shall not be connected to any pipeline system for medical gases and/or vacuum, an anaesthetic gas scavenging system (AGSS), or a heating and recirculating ventilation system.

4.5 Portable and mobile plume evacuation systems shall comply with the applicable requirements for basic safety and essential performance specified in IEC 60601-1.

NOTE National or regional regulations can specify additional requirements.

4.6 The sound pressure level emitted by the PES shall be measured in accordance with [12.2](#) and shall be disclosed in the instructions for use.

NOTE National and regional regulations concerning noise levels within the medical environment can exist.

4.7* Enclosures of portable and mobile plume evacuation systems shall provide at least an IP31 degree of protection when tested according to [12.4.1](#).

4.8 The manufacturer shall evaluate usability in accordance with IEC 62366. Check compliance by inspection of the usability engineering file.

5 Design requirements

5.1 Components

A PES shall include at least the following elements (see figures in [Annexes A](#) and [C](#)):

- a) a capture device with an inlet that can be effectively positioned near the operative site;
- b) transfer tubing;
- c) a filtration system;

NOTE A filtration system can include a pre-filter, final filter and indication(s) of filter life(s) or the need for replacement, and an adsorber.

- d) a flow-generating device;
- e) an exhaust system which extends from the flow-generating device to room air (in the case of a local, portable, or mobile PES) or the outside of the building (in the case of a central system);
- f) a control system;
- g) connectors.

NOTE The arrangement of these components can vary and a single device can incorporate multiple functions.

5.2 Connectors

5.2.1* User-detachable connectors shall not be connectable with connectors in ISO 5356-1 or ISO 80369-1.

NOTE See [Figures A.1](#), [A.2](#), and [A.3](#) for the location of connectors.

5.2.2 For the terminal unit connector, the connecting force shall be a minimum of 25 N and a maximum of 40 N.

5.2.3 For the terminal unit connector, the disconnecting force shall be a minimum of 25 N and a maximum of 40 N.

5.2.4 A terminal unit is shown in [Figure 1](#).

Dimensions in millimetres

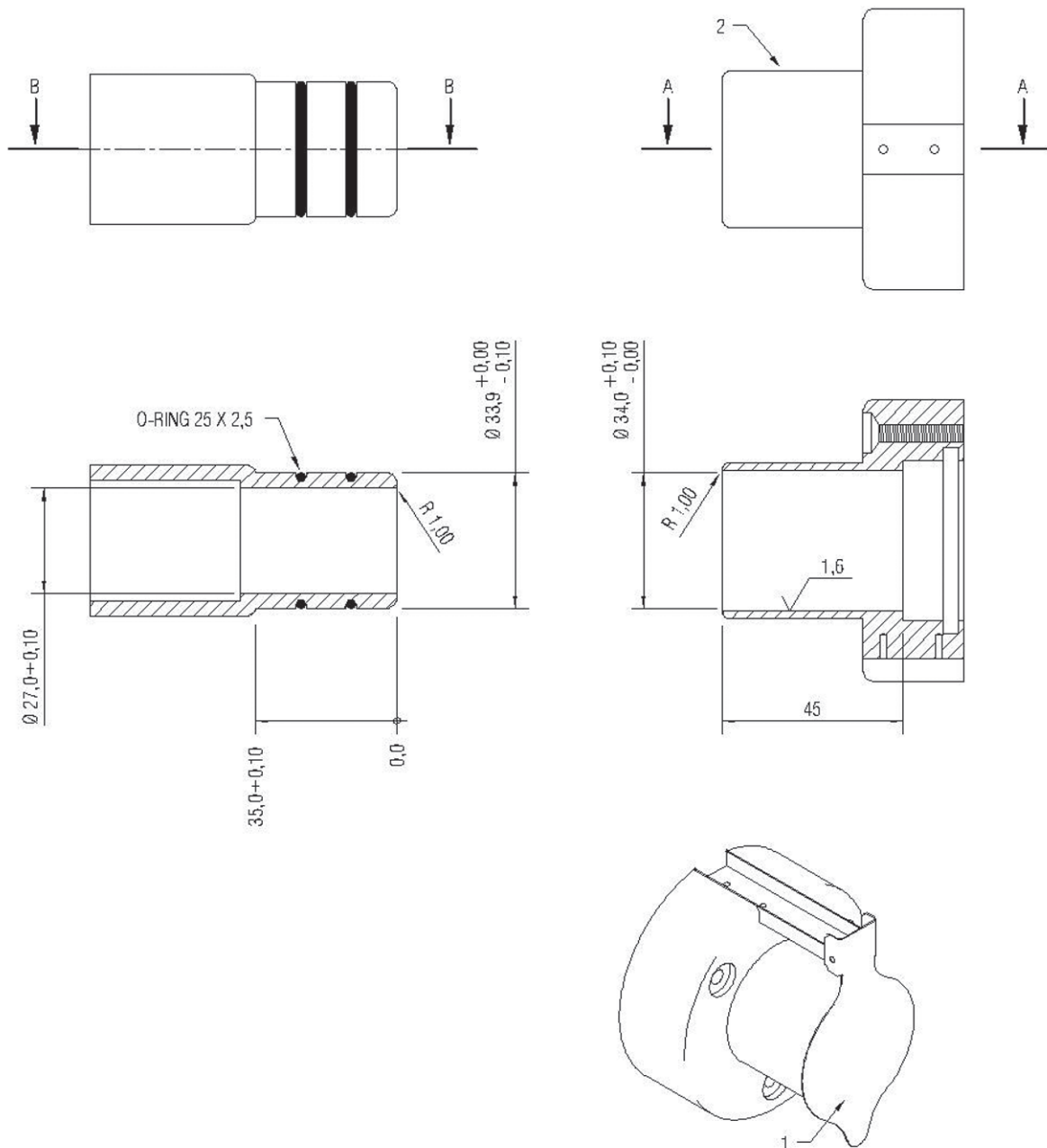

Key

- 1 lid on terminal unit with automatic closing device
- 2 PES terminal

Figure 1 — Plume evacuation system terminal unit

5.3 Supply system for central plume evacuation

5.3.1 A supply system for a central stationary PES shall comprise at least two sources of supply, typically blowers or pumps.

5.3.2* The supply system shall be capable of maintaining the design flow rate of the system when any single source of supply has been removed from service.

5.3.3 The supply system shall be designed so that during maintenance on any source of supply or system component or during a single fault condition on any component of the system, the remaining sources and components shall be capable of supplying the system design flow.

5.3.4 Each source of supply shall have a control circuit arranged so that shutting off, or failure, of one source will not affect the operation of other source(s). The controls shall be arranged so that all the sources of supply service the system in turn or simultaneously. This requirement shall be met in normal condition and in single fault condition.

5.3.5 The supply system for a central PES should be connected to the emergency power supply.

5.3.6 The exhaust(s) from the supply system shall be piped to the outside of the building and shall be provided with means to prevent the ingress of, for example, insects, debris, and precipitation. The location of the exhaust outlet should be remote from the air intake for medical air compressor systems, air intakes, doors, windows, or other openings in buildings. Consideration should be given to the potential effects of prevailing winds on the location of the exhaust(s).

5.3.7 If necessary, means to prevent the transmission of vibration from the supply system to the pipeline shall be provided.

5.3.8 Means to regulate flow to terminal unit(s) can be provided in order to meet the requirements in [7.2](#).

5.3.9 The ambient temperature in rooms for supply systems shall be in the range specified by the manufacturer.

6 Indicating systems

Means shall be provided to indicate to the operator that the PES is operating.

7 Plume extraction system pipeline

7.1 Mechanical integrity

The pipeline distribution system shall maintain its mechanical integrity at a pressure of -30 kPa.

7.2 Pressures and flows

7.2.1 The vacuum level at the inlet to the capture device shall be no less than -15 kPa (i.e. between 0 kPa and -15 kPa).

NOTE This is to avoid trauma to the patient's tissues.

7.2.2 The pressure at any terminal unit shall not be less than 110 % of the nominal pressure with all terminal units closed. The pressure at any terminal unit shall not be less than -10 kPa with the system operating at system design flow.

7.2.3 The PES shall be capable of providing a flow of at least 500 l/minute at the terminal unit with no load.

7.2.4 The system design flow shall be determined by the designer of the PES after consultation with the healthcare institution.

EXAMPLE System design flow can be calculated using a diversity factor based on a single theatre design flow of 500 l/min for the first two theatres and 25 % of the single theatre design flow for each of the remaining theatres.

7.3 Shut-off valves

7.3.1 Where needed, shut-off valves shall be provided to isolate sections of the pipeline distribution system for maintenance, repair, or planned future extensions and to facilitate periodic testing. The nomenclature for shut-off valves shall be as follows:

- a) source shut-off valve;
- b) main shut-off valve;
- c) riser shut-off valve;
- d) branch shut-off valve;
- e) ring shut-off valve;
- f) maintenance shut-off valve.

7.3.2 If not specified, the location of all shut-off valves and the extent of the area served by each shut-off valve shall be determined by the system designer together with the healthcare facility management, using risk analysis procedures in accordance with ISO 14971. Consideration should be given to providing a shut-off valve at the point where the pipeline enters a building unless the main, riser, or branch shut-off valve is accessible within the building.

7.3.3 All shut-off valves shall be identified

- a) to indicate the service name or symbol, and
- b) to indicate the risers, branches, or areas controlled.

This identification shall be secured to the valve or the pipeline and be readily visible at the valve site.

7.3.4 For all manual shut-off valves in a PES, it shall be apparent by observation whether the valve is open or closed.

7.3.5 It shall be possible to isolate each source of supply for maintenance, repair, or planned future extensions and to facilitate periodic testing.

7.3.6 Shut-off valves which cannot be locked in the open or closed position shall be protected from operation by unauthorized personnel.

8 System components

8.1 Capture device

NOTE A capture device can be single use or reusable.

8.1.1 The capture device shall comply with relevant clauses for fire prevention in IEC 60601-1.

Evidence shall be provided by the manufacturer.

8.1.2 Capture devices shall be provided with a means to prevent tissue and other material from the surgical site being drawn into the transfer tubing.

8.1.3 The capture device shall include a means to prevent attachment to intact tissue or a means to break the vacuum.

8.2 Transfer tubing — Kinking

The transfer tubing shall not kink when tested according to ISO 5359.

8.3 Filtration system

8.3.1 The filtration system shall be designed to minimize biohazards and other contamination in the exhaust air. This can be accomplished by using a single multi-purpose filter or more than one filter.

8.3.2 The filtration system shall include an ULPA filter in accordance with EN 1822-1.

8.3.3 The filtration system can contain a pre-filter and/or an adsorber.

NOTE A hydrophobic element is not a necessary component of a pre-filter. A fluid drop out, suction catheter, and labelling to not aspirate fluids are current control methods.

8.3.4 Means shall be provided to indicate when a filter or adsorber change is required according to the manufacturer's instructions.

NOTE This can be accomplished through e.g. pressure drop monitoring or indication, a visual indicator, an audible indicator, or labelling indicating a date for replacement.

8.3.5 The filters shall be designed such that during routine maintenance, there is no biohazard to the user during filter removal and installation (i.e. the user should not be directly in contact with the contaminated filter components).

8.3.6 Local, mobile, and portable PESs shall contain an adsorber when the outlet flow is into the operating room.

8.4 Flow-generating device

8.4.1 Provided that unacceptable risk is not introduced and the PES continues to meet the requirements of this International Standard, the flow-generating device can be used to power other systems.

Check compliance by examination of the risk management file.

NOTE 1 The flow-generating device is usually used only to power the plume evacuation system.

NOTE 2 See [Annex H](#) for guidelines for flow-generating devices consisting of fans, blowers, or dedicated pumps.

8.4.2 A flow-generating device shall be provided downstream of the filtration system.

8.4.3 Means shall be provided in the PES for the operator to adjust the flow.

8.4.4 Flow-generating devices for a central PES consisting of fans, blowers, or dedicated pumps shall not be located in the same room as gas and non-cryogenic liquid cylinder supply systems.

8.4.5 The locations of flow-generating devices for a central PES shall be decided by a risk management process in accordance with ISO 14971.

8.5 Exhaust system

The exhaust port on PESs shall be marked as such and shall include a warning that the exhaust port should not be blocked.

8.6 Control system

The control system shall include an ON-OFF device.

NOTE 1 It can also include one or more of the following:

- a) flow control;
- b) means to control how long the PES continues to evacuate plume after it is turned off (delay control);
- c) a standby mode.

NOTE 2 A wide range of control devices (e.g. electronic footswitches, pneumatic footswitches, sensor devices, and direct cable connections) can be used with PESs. A remote control feature can be coupled with the activation device of the laser or electrosurgical unit.

8.7 Pipelines, tubing, and other components

8.7.1 The materials used for pipelines and other components of the PES shall be corrosion resistant and compatible with plume under the operating conditions specified by the manufacturer.

NOTE 1 Corrosion resistance includes resistance against the influence of moisture and the surrounding materials.

Evidence shall be provided by the manufacturer.

NOTE 2 Regional or national requirements can require the provision of evidence to the competent authority or a conformity assessment body, e.g. notified body in the European Economic Area (EEA), upon request.

8.7.2 If copper pipes are used, they shall comply with the requirements given in EN 13348 or national standards/regulations (e.g. ASTM B819) that can apply.

Evidence shall be provided by the manufacturer.

NOTE 1 Regional or national regulations can require the provision of evidence to the competent authority or a conformity assessment body, e.g. notified body in the European Economic Area (EEA), upon request.

NOTE 2 The use of the same stock of copper pipes as is used for the installation of pipeline systems for compressed medical gases and vacuum is in accordance with ISO 7396-1.

8.7.3 The potential hazards arising from the use of non-metallic pipes and components shall be taken into account, using risk management procedures in accordance with ISO 14971.

NOTE Experience shows that non-metallic pipes and their junctions used in PESs need to be carefully evaluated for their durability following exposure to plume.

8.7.4 If lubricants are used, they shall be compatible with plume under the operating conditions specified by the manufacturer.

Evidence shall be provided by the manufacturer.

NOTE Regional or national regulations can require the provision of evidence to the competent authority or a conformity assessment body, e.g. notified body in the European Economic Area (EEA), upon request.

8.7.5 Precautions shall be taken to maintain the cleanliness of components during transportation, storage, and installation.

9 Terminal units

9.1 Each central PES shall have a PES-specific terminal unit, complying with [Figure 1](#).

9.2 The terminal unit shall have an automatic closing device that seals when not connected.

10 Marking and colour coding

10.1 Marking

10.1.1 Pipelines shall be marked “PES” or the national equivalent and shall have arrows denoting the direction of flow adjacent to valves (if fitted) at junctions and changes of direction, before and after walls and partitions, etc., at intervals of no more than 10 m and adjacent to terminal units.

10.1.2 Marking shall be durable and with letters not less than 6 mm high.

10.1.3 The exhaust outlet of a central plume evacuation system shall be marked as such.

10.2 Colour coding

10.2.1 If colour coding is used, it shall be in accordance with national standards.

10.2.2 The test for durability of markings and colour coding is given in [12.3.10](#).

11 Pipeline installation

When a PES is in a medical supply unit, it shall be installed in accordance with the relevant clauses of ISO 11197.

NOTE 1 Regional or national regulations which apply to electrical installations in buildings can exist.

NOTE 2 Regional or national regulations which apply to continuity of earthing across all joints within the same building and to electrical isolation of different buildings from each other can exist.

12 Testing, commissioning, and certification of the PES

The resolution and accuracy of all measuring devices used for testing shall be appropriate for the values to be measured. All measuring devices used for certification shall be calibrated at appropriate intervals.

12.1 General requirements for tests

Before any testing is carried out, every terminal unit in a central system under test shall be labelled to indicate that the system is under test and shall not be used.

12.2 Noise testing

12.2.1 For portable or mobile PES, place the PES on a sound-reflecting plane and attach the least favourable capturing device with respect to noise, as indicated in the instructions for use. Set the PES flow rate that creates the maximum sound level. Using a microphone of the sound level meter complying with the requirements of type 1 instruments specified in IEC 61672-1, measure the sound pressure levels at 10 positions in a hemisphere with a radius 1 m from the sound generating source.

12.2.2 For local or central PES, place the PES capturing device on a sound-reflecting plane and attach the least favourable capturing device with respect to noise, as indicated in the instructions for use. Set the PES flow rate that creates the maximum sound level. Using a microphone of the sound level meter complying with the requirements of type 1 instruments specified in IEC 61672-1, measure the sound pressure levels at 10 positions in a hemisphere with a radius 1 m from the sound generating source.

12.2.3 Calculate the A-weighted sound pressure level averaged over the measurement surface according to 8.2.2 of ISO 3744:2010.

12.2.4 Verify that the A-weighted background level of extraneous noise, including any information signals, is at least 6 dB below that measured during the test.

12.2.5 Include the measured sound pressure level in the instructions for use.

12.3 Tests, inspections, and checks of a fixed (local stationary or central) PES

12.3.1 General

Tests after completion of installation of a local stationary or central PES system shall be carried out, documented, and certified by the manufacturer.

NOTE Regional or national regulations requiring the manufacturer to have an approved quality system can exist.

An example of a procedure for testing and commissioning for a central system is given in [Annex H](#).

Testing shall be carried out with ambient air.

12.3.2 Leakage

12.3.2.1 Pipelines downstream of the flow-generating device shall be visually inspected for the integrity of all connections.

12.3.2.2 Pipelines between the terminal units and the flow-generating device shall be tested at a pressure of $-15 \text{ kPa} \pm 10 \%$. The pressure increase due to leakage in these sections, after a test period of 15 min, shall be less than 5 kPa with the terminal units blanked off.

12.3.3 Marking and support intervals of the pipeline system

12.3.3.1 The marking of the pipeline system shall meet the requirements of [10.1](#). The colour coding of the pipeline system, if used, shall meet the requirements of [10.2](#).

12.3.3.2 Pipelines shall be supported at intervals to prevent sagging or distortion. Recommended intervals for rigid metallic pipes are given in [Table 1](#).

Table 1 — Recommended intervals between supports for rigid metallic pipes

Outside diameter mm	Maximum intervals between supports^a m
up to 15	1,5
22 to 28	2,0
35 to 54	2,5
greater than 54	3,0

^a Shorter intervals can be required when using rigid non-metallic pipes.

12.3.4 Mechanical function and inspection for cleanliness of the terminal units

It shall be demonstrated for each terminal unit that the appropriate probe can be inserted, captured, and released.

All terminal units shall be inspected for the absence of visible particulate matter.

12.3.5 Cross connection

There shall be no cross connection to any other pipeline system.

12.3.6 Function of flow-generating devices

All flow-generating devices shall operate in accordance with the manufacturer's manuals and specifications.

12.3.7 Pressure and flow at terminal units

It shall be demonstrated that the pressure and flow at each terminal unit is in accordance with [7.2](#).

12.3.8 Control system

The control system shall comply with [8.6](#).

12.3.9 Exhaust system

The exhaust system shall comply with [8.5](#).

12.3.10 Identification and labelling of the terminal unit

On satisfactory completion of the tests, inspections, and checks described in [12.3.1](#) to [12.3.9](#), the construction labels indicating that the system is under test shall be removed. At the same time, the correct identification, labelling, marking, and colour coding (if used) of each terminal unit shall be checked.

12.3.11 Test for durability of markings and colour coding

Rub markings and colour coding by hand, without undue pressure, first for 15 s with a cloth rag soaked with distilled water, then for 15 s with a cloth rag soaked with 100 % ethanol, and then for 15 s with a cloth rag soaked with 100 % isopropanol. Carry out this test at ambient temperature. The markings shall remain legible.

12.3.12 Certification of the central PES system

Before a plume evacuation system is used, it shall be certified in writing to the healthcare facility that all tests given in [12.1](#) and [12.2](#) have been satisfactorily carried out and all requirements of [Clause 4](#) have been met. The results of tests showing details of the areas tested should be part of the permanent record of the healthcare facility.

The system manufacturer shall certify that all drawings and manuals, as required in [Clause 13](#), have been supplied to the owner or client.

12.3.13 Extensions or modifications

When extensions or modifications are made to the system, the appropriate tests in [12.1](#), [12.2](#) and [12.3.2](#) to [12.3.11](#) shall be carried out before the system is returned to service.

12.4 Tests, inspections, and checks of portable and mobile PES

12.4.1 Ingress protection

Compliance with 4.7 is checked using the tests of IEC 60529 with the portable or mobile plume evacuation system placed in the least favourable position of normal use and by inspection. After these procedures, verify that basic safety and essential performance are maintained.

12.4.2 Certification of the portable and mobile PES

Before a plume evacuation system is used, it shall be certified in writing to the healthcare facility that all tests given in [12.2](#) have been satisfactorily carried out and all requirements of [Clause 4](#) have been met. The results of tests should be part of the permanent record of the healthcare facility.

The system manufacturer shall certify that all drawings and manuals, as required in [Clause 13](#), have been supplied to the owner or client.

13 Information to be supplied by the manufacturer

13.1 General

13.1.1 The manufacturer shall provide instructions for the installation, use, servicing, and maintenance of the PES.

13.1.2 The information to be provided by the manufacturer shall be in accordance with EN 1041 or equivalent national standards.

NOTE Regional or national regulations which apply to manufacturers of medical devices can exist.

13.2 Instructions for use

13.2.1 The manufacturer of the complete system or the manufacturer(s) of each component of the evacuation system shall provide the healthcare facility with instructions for use.

13.2.2 The manufacturer shall disclose the method of use for a capture device and the range of flow necessary to meet the performance requirements of this International Standard (see [4.3](#)).

13.2.3 The manufacturer's instructions for use shall cover maintenance, setup, monitoring, replacement, and disposal of all single-use items including, but not limited to, tubing, filters, and capture devices. Instructions for reusable items shall include maintenance, setup, monitoring, and replacement, as well as procedures for cleaning and disinfection or sterilization.

13.2.4 Instructions for disposal of both reusable and single-use items shall be according to procedures for handling biohazardous waste in accordance with the requirements of the authorities having jurisdiction.

13.2.5 The manufacturer shall provide instructions for cleaning and sterilizing reusable capture devices according to regional or national standards.

13.2.6 The manufacturer's instructions for use shall state that disposal of capture devices should be carried out according to infection control procedures for blood-borne pathogens.

13.2.7 The manufacturer shall disclose the lengths and diameters of transfer tubing at which the PES meets its performance specification.

13.2.8 The instructions for use shall contain the following:

- a) the name or trade name of the manufacturer;
- b) the year of manufacture and, where appropriate, the expected lifetime of the system and its components;
- c) any special storage and/or handling conditions;
- d) any special operating instructions;
- e) any warnings and/or precautions to be taken that were identified during risk analysis;
- f) the batch or serial number, if applicable;

- g) a technical specification including the performance of the system, and how to connect and disconnect detachable parts and accessories;
- h) a description of the control systems;
- i) the position in normal condition (i.e. open or closed) of all shut-off valves, if fitted;
- j) instructions for recommended periodic checks of function of the system;
- k) instructions for recommended maintenance tasks and their frequency;
- l) a list of recommended spare parts, if applicable;
- m) information regarding which plumes the system is designed to be used with; and
- n) instructions for the disposal of components or consumables.

13.2.9 The instructions for use shall take into account the possibility that several different organisations might be involved in operation, use, and maintenance.

13.3 Operational management information

13.3.1 The manufacturer(s) of each component of the plume evacuation system shall provide operational management information to the healthcare facility to enable it to produce its operational management document.

13.3.2 The system manufacturer(s) shall provide instructions to the healthcare facility for recommended maintenance tasks and their frequency, and a list of recommended spare parts.

NOTE Informative guidelines for the preparation of the operational management document are given in Annex F of ISO 7396-1:2007. Informative guidelines for carrying out a risk management procedure are given in [Annex D](#).

13.3.3 A separate set of “as-installed” mechanical drawings which show the actual locations of the pipelines, the diameters of the pipelines, shut-off valves, and all other components shall be maintained during construction and shall be brought up to date as changes are made. These drawings shall include details which will enable buried or concealed pipelines to be located.

13.3.4 A complete set of “as-installed” drawings of the pipeline system shall be presented to the healthcare facility for inclusion as part of the permanent record of the healthcare facility.

13.3.5 Electrical diagrams for the components supplied shall be provided by the system manufacturer.

13.3.6 The manufacturer shall disclose the technical specification in accordance with [13.2.7](#).

Annex A (informative)

Types of plume evacuation systems

A.1 General

A.1.1 Plume can be evacuated by the means described in this Annex. Users should note that a particular system will not necessarily be applicable to all plume evacuation situations.

A.1.2 Flows are limited by the tubing size (i.e. the smaller the diameter of the tube, the lower the gas flow rate at a given pressure).

A.1.3 Single-use components include capture devices, transfer tubing, and filters, all of which are considered biohazardous and thus require proper disposal.

A.1.4 Noise caused by the PES can be an issue with clinical staff and the patient. However, the substantial flows of air needed to capture plume will inevitably produce some noise.

A.1.5 A wide range of activation devices (e.g. electronic footswitches, pneumatic footswitches, sensor devices, and direct cable connections) can be used with PESs. A remote activation feature can be coupled with the activation device of the laser or electrosurgical unit.

A.1.6 The capture device collects plume which is then conducted through transfer tubing positioned in accordance with the manufacturer's operating instructions.

A.1.7 Some PESs are designed to be used with electrosurgical devices and have small-lumen capture devices that attach to the electrosurgical hand piece. Other capture devices are integral to the electrosurgical handpiece. Others have wands, nozzles, or hoses.

A.1.8 PES filtration systems typically use multiple-stage filtration. Some PESs are designed to be used with a single-use pre-filter which shall be replaced after each patient.

A.2 Portable and mobile plume evacuation systems

A.2.1 Components

A typical portable or mobile PES has the following components (see [Figure A.1](#)):

- a) capture device that can be a wand, suction tip, connector, or electrosurgical unit adaptor;
- b) transfer tubing;
- c) filtration system;
- d) flow-generating device;
- e) control system;
- f) exhaust port.

A.2.2 System flow rate and negative pressure generation

System flow rate capacity is determined by the configuration and intended use of the system and can range from 3,5 l/min to greater than 2 000 l/min. Most units have an adjustable flow capacity and can produce pressures below -15 kPa.

A.2.3 System characteristics

A typical portable or mobile PES has the following characteristics:

- a) can be used for most procedures in a variety of settings;
- b) powered using a facility's main electricity or batteries;
- c) can operate at 60 dbA or less;
- d) can be easily replaced while undergoing repair;
- e) can have a power cord that is typically placed on the floor (creating an obstacle and tripping hazard);
- f) takes up space in the room where it is used.

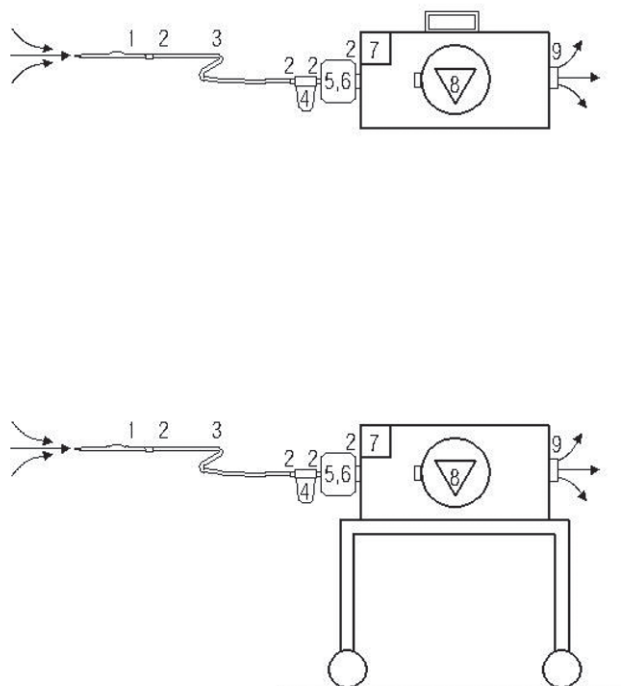

Key

- | | | | |
|---|-----------------|---|------------------------|
| 1 | capture device | 6 | adsorber |
| 2 | connector | 7 | control panel |
| 3 | transfer tubing | 8 | flow-generating device |
| 4 | pre-filter | 9 | exhaust port |
| 5 | ULPA filter | | |

Figure A.1 — Portable (top) and mobile (bottom) plume evacuation systems

A.3 Local stationary plume evacuation systems

A.3.1 General

Local stationary PESs have a flow-generating device located within a medical supply unit or close to the operating room (e.g. in the interstitial space adjacent to the operating room). The connection from the filtration system to the flow-generating device is via a hose. Connections and controls are located on the medical supply unit (see [Figure A.2](#)). The filtration system is connected by the user to the terminal unit.

These PESs capture plume and vent the filtered gas inside the room or outside the building. The filtration system is typically located at the medical supply unit for easy replacement.

A.3.2 Components

A typical local stationary PES has the following components:

- a) a capture device;
- b) transfer tubing;
- c) a filtration system;
- d) flow-generating device inlet tubing;
- e) a flow-generating device;
- f) control system;
- g) exhaust system.

A.3.3 System flow rate

The system flow rate is determined by the configuration and intended use of the system and can range from 3,5 l/min to over 500 l/min.

A.3.4 System characteristics

A typical local stationary PES has the following characteristics:

- a) easily accessible filters;
- b) does not take up floor space;
- c) noisy if the flow-generating device is in the medical supply unit;
- d) relatively quiet if the flow-generating device is remote;
- e) always present in the operating room;
- f) no power cord on floor.

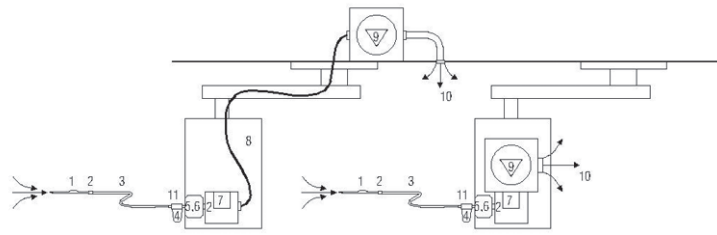

Key

- | | |
|-------------------|---------------------------------------|
| 1 capture device | 7 control system |
| 2 connector | 8 flow-generating device inlet tubing |
| 3 transfer tubing | 9 flow-generating device |
| 4 pre-filter | 10 exhaust |
| 5 ULPA filter | 11 terminal unit |
| 6 adsorber | |

Figure A.2 — Local stationary plume evacuation system

A.4 Central plume evacuation systems

A.4.1 General

These PESs capture plume and convey it through a transfer tubing to the filtration system. The filtered gas is conveyed via terminal units and a pipeline system to a central flow-generating device, and then to the building’s exterior (see [Figure A.3](#)). Central PESs have their flow-generating device permanently installed in the mechanical plant room.

A.4.2 Components

A typical central PES has the following components:

- a) a capture device;
- b) transfer tubing;
- c) a filtration system;
- d) terminal unit;
- e) flow-generating device inlet tubing;
- f) junction point (between the flow-generating inlet tubing and the PES pipeline);
- g) piping to the central source;
- h) a centrally located flow-generating device;
- i) a pipeline pressure control device;
- j) an exhaust system;
- k) a control system, which includes a means to control the flow rate.

A.4.3 System flow rate and pressure characteristics

System flow rate capacity is determined by the configuration and intended use of the system and can range from 3,5 l/min to 500 l/min at the terminal unit. Most units produce vacuum pressures more negative than -15 kPa at the terminal unit.

A.4.4 System characteristics

A typical central PES has the following characteristics:

- a) easily accessible filters;
- b) does not take up floor space;
- c) relatively quiet at the point of use;
- d) always present in the operating room;
- e) requires central maintenance;
- f) has individual flow controls;
- g) powered by facility's main electricity and connected to emergency power system;
- h) can only be used in locations where there is a terminal unit;
- i) dual flow-generating devices permit continuous operation;
- j) no power cord on the floor.

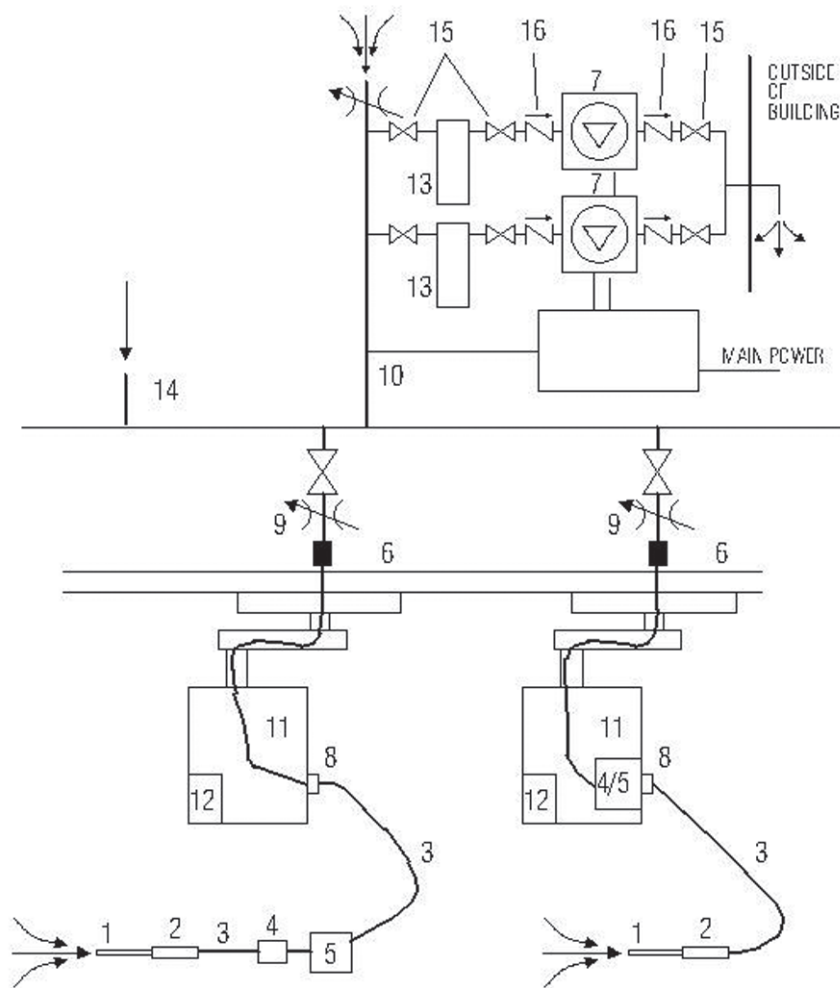

Key

- | | |
|--------------------------|----------------------------|
| 1 capture device | 9 flow control device |
| 2 connector | 10 pressure sensor |
| 3 transfer tubing | 11 evacuation tube |
| 4 pre-filter | 12 control system |
| 5 ULPA filter | 13 activated carbon filter |
| 6 junction point | 14 pressure relief device |
| 7 flow-generating device | 15 shut-off valve |
| 8 terminal unit | 16 non-return valve |

Figure A.3 — Central plume evacuation system

Annex B (informative)

Healthcare facility policies and procedures

B.1 Policies and procedures

B.1.1 Policies

If a facility employs techniques that involve the creation of plume, the facility should have policies to address the potential hazards. These policies should be documented, kept up to date, and aligned with the facility's management systems for quality, occupational health and safety, risk management, infection control, and the environment.

Users should ensure that they are familiar with the applicable legislation (e.g. regional or national occupational health and safety legislation, local health department).

B.1.2 Procedures

A facility should have procedures that address the following:

- a) the purchasing, installation, testing, use, servicing, and regular maintenance of plume evacuation equipment and systems;
- b) personnel training related to the use, servicing, and maintenance of PESs (e.g. positioning of intake, verification of flow settings, filter replacement, and confirmation that the PES is performing to the manufacturer's specifications).

B.2 Protection of patients and staff

NOTE The risk of exposure to plume for patients varies according to the type, duration, and repetitiveness of procedures producing plume, as well as the body site of the procedure, and whether the patient is intubated (i.e. there is a tracheal tube in place) or a supraglottic device such as a laryngeal mask is in use. Facility staff members have a different risk profile, due to repeated exposure.

B.2.1 Procedures should be in place to protect patients and staff from exposure to plume. These procedures should include, but not be limited to, the following.

- a) During a medical or surgical procedure performed in or near respiratory passages, adequate plume removal should be provided for patient protection using a PES. When jet ventilation is applied during laser treatment in the upper respiratory tract, the surgical team should take precautions to ensure that the ventilation flow does not transport plume particles and gases into the patient's respiratory system.
- b) Adequate room ventilation should be provided.

B.2.2 An appropriate person should be designated as facility safety officer. The facility safety officer should ensure that plume removal requirements are established, implemented, monitored for compliance, reviewed, and (if necessary) revised periodically.

NOTE Facility safety officers are also called health and safety officers, risk managers, laser safety officers, and infection control and department managers.

B.2.3 Before PES equipment is purchased, a facility should evaluate which plume evacuation system is most appropriate based on, at a minimum, the following:

- a) the type of procedures that are to be performed;
- b) the size and layout of the procedure room or treatment area;
- c) the expected volume of plume;
- d) the manufacturer's specifications for the equipment;
- e) ease of use;
- f) flammability characteristics of the capture device and transfer tubing.

NOTE Most capture devices for laser use have high flame resistance.

B.2.4 Plume evacuation should be performed using equipment designed specifically for this purpose.

B.3 Personnel

B.3.1 A facility should ensure that everyone working in an environment where plume is created

- a) has access to current plume hazard and safety information,
- b) has been appropriately trained in the use of the PES, and
- c) annually demonstrates competency in the use of the PES.

The facility should maintain documentation that provides evidence of appropriate employee training and annual competency evaluation.

B.3.2 Facility personnel who are responsible for maintaining the PES should be trained in the proper maintenance and disposal of the components of the system.

B.4 Control measures

B.4.1 A facility should use control measures that are appropriate for the level and type of plume being generated.

B.4.2 Masks, including particle respirator masks and laser surgical masks, should not be used as the primary method of protection against occupational exposure to plume.

NOTE Although surgical masks are designed to protect patients from aerosols and droplets coming from the noses or mouths of health care personnel, they provide only minimal protection against plume. Masks can become even less effective when they are wet or damp.

B.4.3 As a secondary line of defence, the following can be used:

- a) adequate room exhaust ventilation;
- b) eye, face, and respiratory protection.

NOTE Adequate respiratory protection against plume is too bulky for surgical use.

B.4.4 The inlet of the capture device should be kept as close as possible to the site of plume generation.

NOTE The US Center for Disease Control (CDC) and the American Operating Room Nurses (AORN) recommend that the capture device be held 2 cm to 5 cm from the site or as close as possible.

B.4.5 Personnel should observe standard precautions against exposure to blood-borne pathogens when entering or working in a zone where infectious material from plume could be present in the air or on surfaces.

Annex C (informative)

Typical plume capture devices and transfer tubings

Typical plume capture devices and transfer tubings are shown in [Figure C.1](#).

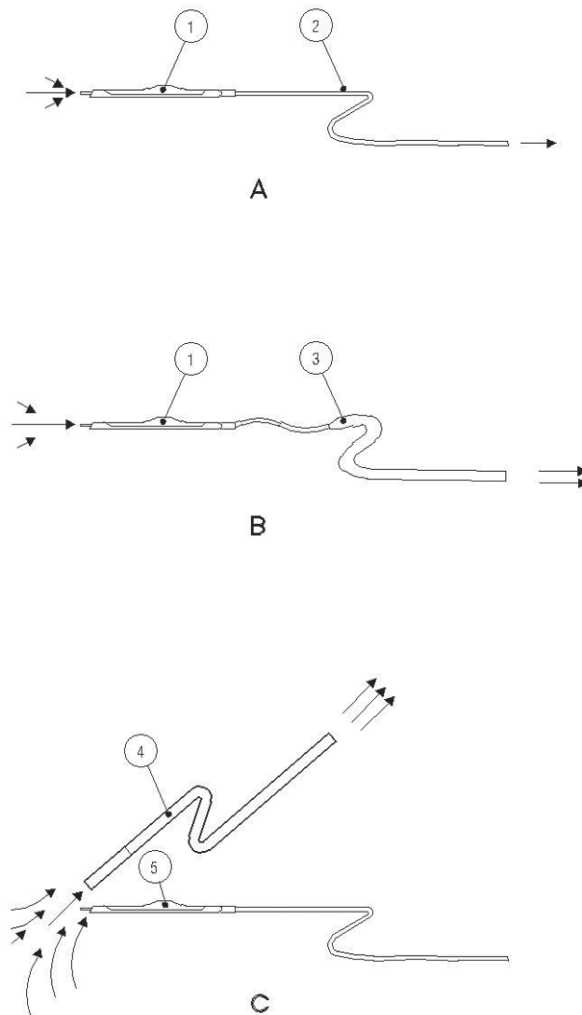

Key

- 1 device generating plume with integral or removable capture device
- 2 small diameter transfer tubing for low flow applications
- 3 larger diameter transfer tubing for higher flow applications
- 4 capture device separate from device generating plume
- 5 device generating plume without integral or attached capture device

Figure C.1 — Typical plume capture devices and transfer tubing

Annex D (informative)

Risk management checklist

D.1 General

A risk assessment is a thorough look at the workplace to identify situations, processes, etc. that can cause harm. A risk assessment performed before policies and procedures are developed is useful for determining engineering controls and work practices to reduce the risk of plume exposure through the following:

- a) identification of hazards;
- b) evaluation of the risks associated with those hazards;
- c) determination of appropriate ways to eliminate or control the hazards.

D.2 Hazards identified

Hazards identified are as follows:

- a) discontinuity of operation;
- b) incorrect pressure;
- c) incorrect flow;
- d) transfer of infection;
- e) fire;
- f) exposure of patient and staff to plume.

Annex E (informative)

Operational management

E.1 The manufacturer(s) of each component of the plume evacuation system shall provide operational management information to the healthcare facility to enable it to draft its operational management document.

E.2 The system manufacturer(s) shall provide instructions to the healthcare facility for recommended maintenance tasks and their frequency, and a list of recommended spare parts.

NOTE Informative guidelines for the preparation of the operational management document are given in Annex G of ISO 7396-1:2007. Informative guidelines for carrying out a risk management procedure are given in [Annex D](#).

Annex F **(informative)**

Rationale

The following correspond to the clauses and subclauses in this International Standard marked with an *. The numbering is, therefore, not consecutive.

1.3 A device for removal of plume generated during invasive procedures has applied parts connected to the patient and introduces new patient risks not addressed in this International Standard. The subcommittee felt that requirements for these devices would be better addressed in a separate standard.

4.4 The pressures and flows generated by medical vacuum and anaesthetic gas scavenging systems (AGSSs) are inappropriate for plume evacuation.

NOTE The use of anaesthetic gas scavenging systems for non-AGSS applications is prohibited by ISO 7396-2.

4.7 IP31 was chosen with the understanding that these flow producers will include rotating equipment (fans, regenerative blowers, etc.). Therefore, it is essential that no one be able to insert a finger into the housing which might be caught or cut by the rotating machinery, requiring a 3 rating for ingress of solids. It is understood that these electrically powered devices will commonly be placed (typically on the floor) in operating theatres. Liquids hanging on stands or set on trays is normal practice in these occupancies. This potentially exposes the device to dripping liquids or in extreme cases to liquids falling onto them. They therefore need a degree of protection against dripping water and require a 1 rating against ingress of liquids.

5.2.1 This requirement is to ensure that the transfer tubing connector is not compatible with a 22 mm conical connector or a 19 mm or 15 mm connector.

5.3.2 The requirement for each source of supply to be capable of supplying the system design flow is to ensure continuity of supply during a single fault condition.

Annex G (informative)

Example of procedure for testing and commissioning for a central system

G.1 General

This test procedure is given as an example of how the specifications of [Clause 12](#) can be verified so that the system can be commissioned and certified. Other procedures which validly test these specifications can be devised. In this procedure, the given sequence of tests is important and should be followed.

When the results of a test do not meet the pass criteria, remedial work shall be carried out and previous tests repeated as necessary.

G.2 Inspection and tests for leakage

G.2.1 Inspection

Visually inspect the exhaust pipeline system for the integrity of all connections.

G.2.2 Test for leakage

Isolate the flow-generating device from the pipeline. Open all shut-off valves (if fitted) and blank off all terminal units. Connect a suitable pressure-measuring device to the system under test. Fill the system with clean, oil-free, dry compressed gas at a pressure of $70 \text{ kPa} \pm 10 \%$. Record the pressure and, after a period of 15 min, record the pressure again. The pressure drop shall not exceed 10 kPa.

NOTE There is no allowance for temperature variation in this test.

G.3 Inspection for marking and support intervals of the pipeline system

Visually inspect that marking has been correctly placed on the pipeline system, especially adjacent to T-connections and where the pipeline system passes through walls or partitions. Check that marking complies with [10.1](#) and colour coding, if used, complies with [10.2](#). Check that the support intervals comply with [12.3.3.2](#).

G.4 Check of mechanical function and inspection for cleanliness of the terminal units

G.4.1 Insert a test probe into each terminal unit in turn. Check that the probe can be inserted, captured, and released.

G.4.2 Check each terminal unit for the absence of visible particulate matter.

G.5 Test for cross connection

Test the pipeline system of the plume evacuation system for cross connection to any medical gas or vacuum or anaesthetic gas scavenging pipeline system. With all flow-generating devices switched off and with pressure in all other medical gas or vacuum pipeline systems, check at all plume evacuation terminal units that there is no positive or negative pressure.

G.6 Tests for function of flow-generating devices

Test all flow-generating devices for operation in accordance with the manufacturer's manuals and specifications.

G.7 Test for pressure and flow at the terminal units

Check that the pressures and flows at the terminal units are as given in [7.2](#).

G.8 Check of the indicating system

Check functioning of the means provided to indicate to the operator that the flow-generating device is operating.

G.9 Check of the plume evacuation system exhaust

Verify that the exhaust from the plume evacuation system:

- is piped either to the outside or into the exhaust conduit of a non-recirculating ventilation system;
- is provided with a means to prevent the ingress of insects;
- is in a position where the risk of contamination of occupied buildings is minimized;
- has a warning label (if fitted) that is legible.

G.10 Check of identification and labelling of the terminal units

Check that the tests in [G.2](#) to [G.9](#) have been completed satisfactorily.

Remove the construction label on each terminal unit which indicates that the system is not to be used. Do not remove these labels unless all preceding tests have been completed satisfactorily. At the same time, check for the correct identification and labelling, marking, and colour coding (if used) of each terminal unit.

Annex H (informative)

Guidelines for flow-generating devices consisting of fans or blowers

H.1 Services containing combustible gases or liquids should not be permitted within the flow-generating device area.

H.2 All electrical fittings in flow-generating device rooms should be located in fixed positions to minimize the risk of physical damage.

H.3 Fire-fighting equipment should be provided within the flow-generating device area.

NOTE Regional or national regulations which apply to fire protection can exist.

H.4 The flow-generating device area should be well ventilated to the open air. Ducting for such ventilation should not be connected to ducting servicing any other building.

H.5 The doors or gate should be capable of being locked. An emergency exit, which should be free from obstructions at all times, should be provided. It should be possible to open any door from the inside without a key at all times. All doors should open outwards.

H.6 Flow-generating device rooms should

- a) comply with local building codes, and
- b) have a warning notice "NO SMOKING", or similar, clearly displayed on both sides of each door or gate.

H.7 [H.1](#) to [H.6](#) apply to flow-generating devices which are centrally located. Flow-generating devices that are not centrally located and might or might not be connected to a pipeline system should be installed and serviced in accordance with the instructions supplied by the manufacturer.

Bibliography

- [1] ISO 5356-1:2004, *Anaesthetic and respiratory equipment — Conical connectors — Part 1: Cones and sockets*
- [2] ISO 7396-2:2007, *Medical gas pipeline systems — Part 2: Anaesthetic gas scavenging disposal systems*
- [3] ISO 15001:2010, *Anaesthetic and respiratory equipment — Compatibility with oxygen*
- [4] ISO 80369-1:2010, *Small-bore connectors for liquids and gases in healthcare applications — Part 1: General requirements*
- [5] IEC 60529:2004, *Degrees of protection provided by enclosures (IP Code)*
- [6] IEC 60601-6-08, *Medical electrical equipment – Part 1-8: General requirements for basic safety and essential performance - Collateral standard: General requirement, tests and guidance for alarm systems in medical electrical equipment and medical electrical systems*
- [7] IEC 60825, *Safety of laser products package*
- [8] ASTM B819:2006, *Standard specification for seamless copper tube for medical gas systems*
- [9] ANSI Z136.3, *Safe use of lasers in health care facilities*
- [10] CSA Z305.13-09, *Plume scavenging in surgical, diagnostic, therapeutic, and aesthetic settings*
- [11] C22.1 HB-06, *CE Code Handbook, An explanation of rules of the Canadian electrical code*
- [12] CAN/CSA-Z317.2-01 (R2008), *Special requirements for heating ventilation, and air conditioning (HVAC) systems in health care facilities*
- [13] Z386-08, *Safe use of lasers in healthcare facilities* (Secretary unable to find on Internet)
- [14] CAN/CSA-Z7396.1-09, *Medical gas pipeline systems – Part 1: Pipelines for medical gases and vacuum*
- [15] CAN/CSA-Z7396.2-02 (R2007), *Medical gas pipeline systems – Part 2: Anaesthetic gas scavenging disposal systems*
- [16] BALL K. Are your ORs smoke free? *Outpatient Surgery Magazine*. 2009, **10** (12) pp. 39–43
- [17] TAYLOR S. The OR: Smoking in a designated non-smoking area. *Canadian Operating Room Nurse Journal* 2009; 27:68, 12-13, 21-22
- [18] YEH C.R. Surgical smoke plume: Principles and function of smoke, aerosol, gases, and smoke evacuators. *Surgical Services Management*. 1997, **3** (4) pp. 41–45
- [19] ZIEGLER B.L. et al. Generation of infectious retrovirus aerosol through medical laser irradiation. *Lasers Surg. Med.* 1998, **22** pp. 37–41
- [20] NFPA (National Fire Protection Association) 115-08, *Standard for Laser Fire Protection*
- [21] ALBRECHT H., & WAESCHE W. 1996. Evaluation of potential health hazards caused by laser and RF surgery. *SPIE Proceedings* 262 4:200–204
- [22] American Conference of Governmental Industrial Hygienists (ACGIH). 2007. *Industrial Ventilation: A Manual of Recommended Practice for Operation and Maintenance*. Cincinnati, OH: ACGIH
- [23] AORN Advanced Technology Specialty Assembly. 1997. *Setting up a smoke-safe OR environment*. 2–3

- [24] AORN AND AORN FOUNDATION. 1997. Proceedings from the smoke roundtable discussion of experts. Denver, CO. pp. 1-21
- [25] AORN AND AORN FOUNDATION. 1997. Summary of proceedings from the second smoke roundtable discussion of experts. Denver, CO. pp. 1-14
- [26] BALL K. Surgical Modalities. In: *Alexander's Care of the Patient in Surgery*, (ROTHROCK J. ed.). Mosby, St. Louis, MO, Twelfth Edition, 2003
- [27] BIGONY L. Risks associated with exposure to surgical smoke plume: A review of the literature. *AORN J.* 2007, **86** (6) pp. 1013-1024
- [28] BRANDON H.J., & YOUNG V.L. 1996. Characterization of electrosurgical smoke. 65th Annual Meeting of the American Society of Plastic and Reconstructive Surgeons, Dallas, TX
- [29] BRANDON H.J., & YOUNG V.L. Characterization and removal of electrosurgical smoke. *Surgical Services Management.* 1997, **3** (3) pp. 14-16
- [30] BRÜSKE-HOHLFELD I., PREISLER G., KARL-WALTER J., PITZ M., NOWAK D., PETERS A. et al. Surgical smoke and ultrafine particles. *J. Occup. Med. Toxicol.* 2008, **3** p. 31
- [31] CANESTRI F. The fluidodynamics of potentially neoplastic plumes produced by medical lasers: First quantitative non-tissue-specific measurements using PMMA samples (Phase I). *J. Clin. Laser Med. Surg.* 1999, **17** (5) pp. 199-203
- [32] CAPIZZI P.J., CLAY R.P., BATTEY M.J. Microbiologic activity in laser resurfacing plume and debris. *Lasers Surg. Med.* 1998, **23** pp. 172-174
- [33] COLE GM, & WILLIAMS CR 1999. Surgical smoke: a cause for concern? *ACORN Journal* 12(1): 23-24, 26
- [34] DESCOTEAUX J.G., PICARD P., POULIN E.C., BARIL M. Preliminary study of electrocautery smoke particles produced in vitro and during laparoscopic procedures. *Surg. Endosc.* 1996, **10** (2) pp. 152-158
- [35] DIKES C. Is it safe to allow smoke in our operating room? *Today's Surg. Nurse.* 1999, **29** (2) pp. 15-21
- [36] ECRI INSTITUTE. Cleaning clogged wall vacuum inlets. *Health Devices.* 1996, **25** (12) pp. 479
- [37] ECRI INSTITUTE. Surgical smoke: Is it regulated? *Health Devices.* 1996, **25** (12)
- [38] ECRI INSTITUTE. ESU-pencil-based smoke evacuation wands. Evaluation. *Health Devices.* 1997, **26** (4) pp. 173-176
- [39] ECRI INSTITUTE. Surgical smoke evacuation systems. *Health Devices.* 1997, **26** (4) pp. 132-172
- [40] ECRI INSTITUTE. ESU-pencil-based smoke evacuation wands. Update Evaluation. *Health Devices.* 1999, **28** (9) pp. 363-365
- [41] ECRI INSTITUTE. Surgical smoke evacuation systems. Update evaluation. *Health Devices.* 1999, **28** (9) pp. 333-362
- [42] ECRI INSTITUTE. Stationary surgical smoke evacuation systems. *Health Devices.* 2001, **30** (3) pp. 73-86
- [43] ECRI INSTITUTE. Smoke evacuation systems, surgical. ECRI Healthcare Product Comparison System (HPCS). *Database.* 2007
- [44] FERNANDES C., & TALIKWA L. Viewpoint. ExtendEVAC point-of-origin smoke evacuation. *Surgical Services Management.* 2000, **6** (2) pp. 18-20
- [45] GIORDANO BP 1996. Don't be a victim of surgical smoke. *AORN Journal* 63(3):520, 522

- [46] GIORDANO BP 1997. Subjective reports + reliable data = regulation of surgical smoke plume evacuation. *AORN Journal* 65(4): 696, 697
- [47] GLOSTER H.M., & ROENIGK R.K. Risk of acquiring human papillomavirus from the plume produced by the carbon dioxide laser in the treatment of warts. *J. Am. Acad. Dermatol.* 1995, **32** (3) pp. 436–441
- [48] GUYDER R. Management of smoke and plume. *ACORN Journal.* 1999, **12** (1) pp. 38–40
- [49] HAFERKAMP H.F., VON ALVENSLEBEN D., SEEBAUM M. Goede, Püster T. 1997. Air contaminants generated during laser processing of organic materials and protective measures. Proceedings of the International Laser Safety Conference, Orlando, Florida. pp. 209–218
- [50] HENSMAN C., BATY D., WILLIS R.G., CUSCHIERI A. Chemical composition of smoke produced by high-frequency electrosurgery in a closed gaseous environment. An in vitro study. *Surg. Endosc.* 1998, **12** (8) pp. 1017–1019
- [51] HENSMAN C., NEWMAN E.L., SHIMI S.M., CUSCHIERI A. Cytotoxicity of electro-surgical smoke produced in an anoxic environment. *Am. J. Surg.* 1998, **175** (3) pp. 240–241
- [52] HINDER F., MATSUMOTO N., BOOKE M., BRADFORD D.W., TRABER L.D., HERNDON D.N. et al. Inhalation injury increases the anastomotic bronchial blood flow in the pouch model of the left ovine lung. *Shock.* 1997, **8** (2) pp. 131–135
- [53] HITCHCOCK R.T. ed. *LIA Guide to Non-beam Hazards Associated with Laser Use.* Laser Institute of America, Orlando, FL, 1999
- [54] HITCHCOCK R.T., & PATTERSON R.M. *Radio-Frequency and ELF Electromagnetic Energies: A Handbook for Health Professionals.* Van Nostrand Reinhold, New York, 1995
- [55] HOGLAN M. Potential hazards from electrosurgery plume: recommendations for surgical smoke evacuation. *Can. Oper. Room Nurs. J.* 1995, **13** (4) pp. 10–16
- [56] Hospital Employee Health. 2000. OSHA's next assignment: protecting operating room staff from surgical smoke: surgical plume contains toxic chemicals, viral matter. *Hospital Employee Health* 19(4):37–39, 48
- [57] HUNTER J. Laser smoke evacuator: effective removal of mutagenic cautery smoke. *Aesthetic Plast. Surg.* 1996, **20** (2) pp. 177–178
- [58] JOHNSON A.R., DIMICH-WARD H.D., MANFREDA J., BECKLAKE M.R., ERNST P., SEARS M.R. et al. Occupational asthma in adults in six Canadian communities. *Am. J. Respir. Crit. Care Med.* 2000, **162** (6) pp. 2058–2062
- [59] KESTENBAUM A.R., COYLE J., SOLAN P.P. Safe laser system design for production. *J. Laser Appl.* 1995, **7** pp. 31–37
- [60] KLESTY K. Laser, cautery laparoscopic procedures require some evacuation. *Advanced Technology in Surgical Care.* 1995, **13** (2) pp. 17–20
- [61] KUNACHAK S., & SOBHON P. The potential alveolar hazard of carbon dioxide laser-induced smoke. *J. Med. Assoc. Thai.* 1998, **81** (4) pp. 278–282
- [62] LANFRANCHI J.A. Practical innovation. Smoke plume evacuation in the OR. *AORN J.* 1997, **65** (3) pp. 627–633
- [63] LANZAFAME R.J. “Smoking” guns [editorial]. *Lasers Surg. Med.* 1997, **20** (3) pp. 354–355
- [64] LAWRENCE LIVERMORE NATIONAL LABORATORY. Laser dyes. Environment, Safety and Health Manual, Section 14.11. <https://esh.llnl.gov/esh-manual/volume2.html#s14>
- [65] MILLER R.L. Characteristics of blood-containing aerosols generated by common powered dental instruments. *Am. Ind. Hyg. Assoc. J.* 1995, **56** pp. 670–676

- [66] NATIONAL INSTITUTE OF OCCUPATIONAL SAFETY AND HEALTH (NIOSH). 1998. Control of smoke from laser/electric surgical procedures. DHHS (NIOSH) Publication No. 96-128. <http://www.cdc.gov/niosh/hc11.html>
- [67] OCCUPATIONAL SAFETY AND HEALTH ADMINISTRATION (OSHA). 2008. Laser/electrosurgery plume [Web page]. <http://www.osha.gov/SLTC/laserelectrosurgeryplume/index.html>
- [68] O'GRADY K.F., & EASTY A.C. Electrosurgery smoke: hazards and protection. *J. Clin. Eng.* 1996, **21** (2) pp. 149–155
- [69] OTT D. Proposal for a standard for laser plume filter technology. *J. Laser Appl.* 1994, **6** (2) pp. 108–110
- [70] SAKURAI H., JOHNIGAN R., KIKUCHI Y., HARADA M., TRABER L.D., TRABER D.L. Effect of reduced bronchial circulation on lung fluid flux after smoke inhalation in sleep. *J. Appl. Physiol.* 1998, **84** (3) pp. 980–986
- [71] SCHULTZ L., & DROGUE J. 2000. Viewpoint: Unique devices for effectively removing surgical plume. *Surgical Services Management* 6 (4:8):11–12
- [72] SMALLEY P.J. Laser hazards, risks and control measures: a perioperative perspective on standards and safety management. *ACORN Journal.* 1999, **12** (1) pp. 30–37
- [73] TREFFLER B. et al. Investigations of pulsed laser tissue ablation by short-time exposure video recording and image processing. *Proc. SPIE.* 1996, **2624** pp. 226–233
- [74] WASCHE W., & ALBRECHT H. Investigation of the distribution of aerosols and VOC in plume produced during laser treatment under OR conditions. *Proc. SPIE.* 1996, **2624** pp. 270–275
- [75] WEBER L. Spreading of infectious materials from the laser interaction zone: Viruses and bacteria. *Proc. SPIE.* 1996, **2923** pp. 178–181
- [76] WEBER L., & MEIER T. Concepts of risk assessment of complex chemical mixtures in laser pyrolysis fumes. *Proc. SPIE.* 1996, **2624** pp. 259–269
- [77] WEIGMANN H.-J. et al. Permanent gases and highly volatile organic compounds in laser plume. *Proc. SPIE.* 1996, **2923** pp. 164–167
- [78] WICKER P. Back to basics. Electrosurgery in perioperative practice. *Br. J. Perioper. Nurs.* 2000, **10** (4) pp. 221–226
- [79] WILLEKE K. et al. Penetration of airborne microorganisms through a surgical mask and a dust/mist respirator. *Am. Ind. Hyg. Assoc. J.* 1996, **57** pp. 348–355
- [80] WINSTIN C. The effects of smoke plume generated during laser and electrosurgical procedures. *Minim. Invasive Surg. Nurs.* 1994, **8** (3) pp. 99–102
- [81] WOLLMER W. 1997. Protection measures against the influences of laser plume in medical applications. Proceedings of the International Laser Safety Conference, Orlando, Florida. pp. 372–382
- [82] YEH C.R. 1997. New capture and collection technology assures removal of surgical smoke. Proceedings of the International Laser Safety Conference. Orlando, FL. pp. 393–395
- [83] KRACHT J., BUSCH-VISHNIAC I.J., WEST J.E. Noise in the operating room 151st ASA Meeting, Providence RI
- [84] Seamlessly Integrating Surgical Smoke Evacuation
- [85] DENNIS V. What's new in cutting and sealing technologies. *Outpatient Surgery Magazine*, September, 2012. p 138-145

British Standards Institution (BSI)

BSI is the national body responsible for preparing British Standards and other standards-related publications, information and services.

BSI is incorporated by Royal Charter. British Standards and other standardization products are published by BSI Standards Limited.

About us

We bring together business, industry, government, consumers, innovators and others to shape their combined experience and expertise into standards-based solutions.

The knowledge embodied in our standards has been carefully assembled in a dependable format and refined through our open consultation process. Organizations of all sizes and across all sectors choose standards to help them achieve their goals.

Information on standards

We can provide you with the knowledge that your organization needs to succeed. Find out more about British Standards by visiting our website at bsigroup.com/standards or contacting our Customer Services team or Knowledge Centre.

Buying standards

You can buy and download PDF versions of BSI publications, including British and adopted European and international standards, through our website at bsigroup.com/shop, where hard copies can also be purchased.

If you need international and foreign standards from other Standards Development Organizations, hard copies can be ordered from our Customer Services team.

Subscriptions

Our range of subscription services are designed to make using standards easier for you. For further information on our subscription products go to bsigroup.com/subscriptions.

With **British Standards Online (BSOL)** you'll have instant access to over 55,000 British and adopted European and international standards from your desktop. It's available 24/7 and is refreshed daily so you'll always be up to date.

You can keep in touch with standards developments and receive substantial discounts on the purchase price of standards, both in single copy and subscription format, by becoming a **BSI Subscribing Member**.

PLUS is an updating service exclusive to BSI Subscribing Members. You will automatically receive the latest hard copy of your standards when they're revised or replaced.

To find out more about becoming a BSI Subscribing Member and the benefits of membership, please visit bsigroup.com/shop.

With a **Multi-User Network Licence (MUNL)** you are able to host standards publications on your intranet. Licences can cover as few or as many users as you wish. With updates supplied as soon as they're available, you can be sure your documentation is current. For further information, email bsmusales@bsigroup.com.

BSI Group Headquarters

389 Chiswick High Road London W4 4AL UK

Revisions

Our British Standards and other publications are updated by amendment or revision.

We continually improve the quality of our products and services to benefit your business. If you find an inaccuracy or ambiguity within a British Standard or other BSI publication please inform the Knowledge Centre.

Copyright

All the data, software and documentation set out in all British Standards and other BSI publications are the property of and copyrighted by BSI, or some person or entity that owns copyright in the information used (such as the international standardization bodies) and has formally licensed such information to BSI for commercial publication and use. Except as permitted under the Copyright, Designs and Patents Act 1988 no extract may be reproduced, stored in a retrieval system or transmitted in any form or by any means – electronic, photocopying, recording or otherwise – without prior written permission from BSI. Details and advice can be obtained from the Copyright & Licensing Department.

Useful Contacts:

Customer Services

Tel: +44 845 086 9001

Email (orders): orders@bsigroup.com

Email (enquiries): cservices@bsigroup.com

Subscriptions

Tel: +44 845 086 9001

Email: subscriptions@bsigroup.com

Knowledge Centre

Tel: +44 20 8996 7004

Email: knowledgecentre@bsigroup.com

Copyright & Licensing

Tel: +44 20 8996 7070

Email: copyright@bsigroup.com



...making excellence a habit.™