

BS ISO 16531:2013



BSI Standards Publication

**Surface chemical analysis —
Depth profiling — Methods for
ion beam alignment and the
associated measurement of
current or current density for
depth profiling in AES and XPS**

bsi.

...making excellence a habit.™

National foreword

This British Standard is the UK implementation of ISO 16531:2013.

The UK participation in its preparation was entrusted to Technical Committee CII/60, Surface chemical analysis.

A list of organizations represented on this committee can be obtained on request to its secretary.

This publication does not purport to include all the necessary provisions of a contract. Users are responsible for its correct application.

© The British Standards Institution 2013. Published by BSI Standards Limited 2013

ISBN 978 0 580 74315 3

ICS 71.040.40

Compliance with a British Standard cannot confer immunity from legal obligations.

This British Standard was published under the authority of the Standards Policy and Strategy Committee on 31 May 2013.

Amendments issued since publication

Date	Text affected
------	---------------

**Surface chemical analysis — Depth
profiling — Methods for ion beam
alignment and the associated
measurement of current or current
density for depth profiling in AES and
XPS**

*Analyse chimique des surfaces — Profilage d'épaisseur — Méthodes
d'alignement du faisceau d'ions et la mesure associée de densité de
courant ou de courant pour le profilage d'épaisseur en AES et XPS*





COPYRIGHT PROTECTED DOCUMENT

© ISO 2013

All rights reserved. Unless otherwise specified, no part of this publication may be reproduced or utilized otherwise in any form or by any means, electronic or mechanical, including photocopying, or posting on the internet or an intranet, without prior written permission. Permission can be requested from either ISO at the address below or ISO's member body in the country of the requester.

ISO copyright office
Case postale 56 • CH-1211 Geneva 20
Tel. + 41 22 749 01 11
Fax + 41 22 749 09 47
E-mail copyright@iso.org
Web www.iso.org

Published in Switzerland

Contents

Page

Foreword	iv
Introduction	v
1 Scope	1
2 Normative references	1
3 Terms, definitions, symbols and abbreviated terms	1
4 System requirements	2
4.1 General.....	2
4.2 Limitations.....	2
5 Ion beam alignment methods	3
5.1 General.....	3
5.2 Important issues to be considered prior to ion beam alignment.....	3
5.3 Alignment using circular-aperture Faraday cup.....	6
5.4 Alignment using elliptical-aperture Faraday cup.....	9
5.5 Alignment using images from ion-induced secondary electrons during ion beam rastering.....	9
5.6 Alignment in X-ray photoelectron microscope/photoelectron imaging system.....	11
5.7 Alignment by observing direct ion beam spot or crater image during and/or after ion sputtering.....	12
5.8 Alignment by observing phosphor sample.....	13
6 When to align and check ion beam alignment	13
Annex A (informative) Comparison of AES depth profiles with good/poor ion beam alignment	14
Annex B (informative) Alignment using cup with co-axial electrodes	16
Bibliography	18

Foreword

ISO (the International Organization for Standardization) is a worldwide federation of national standards bodies (ISO member bodies). The work of preparing International Standards is normally carried out through ISO technical committees. Each member body interested in a subject for which a technical committee has been established has the right to be represented on that committee. International organizations, governmental and non-governmental, in liaison with ISO, also take part in the work. ISO collaborates closely with the International Electrotechnical Commission (IEC) on all matters of electrotechnical standardization.

The procedures used to develop this document and those intended for its further maintenance are described in the ISO/IEC Directives, Part 1. In particular the different approval criteria needed for the different types of ISO documents should be noted. This document was drafted in accordance with the editorial rules of the ISO/IEC Directives, Part 2. www.iso.org/directives

Attention is drawn to the possibility that some of the elements of this document may be the subject of patent rights. ISO shall not be held responsible for identifying any or all such patent rights. Details of any patent rights identified during the development of the document will be in the Introduction and/or on the ISO list of patent declarations received. www.iso.org/patents

Any trade name used in this document is information given for the convenience of users and does not constitute an endorsement.

The committee responsible for this document is ISO/TC 201, *Surface chemical analysis*, Subcommittee SC 4, *Depth profiling*.

Introduction

In surface chemical analysis with AES (Auger electron spectroscopy) and XPS (X-ray photoelectron spectroscopy), ion sputtering has been extensively incorporated for surface cleaning and for the in-depth characterization of layered structures in many devices and materials. Currently, ultra-thin films of < 10 nm thickness are increasingly used in modern devices and so lower energy ions are becoming more important for depth profiling. For reproducible sputtering rates and for good depth resolution, it is important to align the ion beam at the optimal position. This optimization becomes increasingly critical as better and better depth resolutions are required. It is not necessary to conduct a beam alignment routinely but it is necessary to align the beam when instrument parameters change as a result, for example, from replacement of ion-gun filaments or from an instrument bake-out. During the beam alignment, care must be taken not to sputter or otherwise affect specimens for analysis on the sample holder. Instruments have different facilities to conduct alignment and seven methods are described to ensure that most analysts can conduct at least one method. Two of these methods are also useful for measuring the ion beam current or the current density — important when measuring sputtering yields and for measuring sputtering rate consistency. With commercial instruments, the manufacturer may provide a method and equipment to conduct the beam alignment. If this is adequate, the methods described here may not be necessary but may help to validate that method.

ISO 14606^[1] describes how the depth resolution may be measured from a layered sample and used to monitor whether the depth profiling is adequate, properly optimized or behaving as intended. That method, from the instrumental setup to the depth resolution evaluation via in-depth measurement is, however, time-consuming and so the present, quicker procedure is provided to ensure that the ion beam is properly aligned as the first step to using ISO 14606 or for more routine checking.

Surface chemical analysis — Depth profiling — Methods for ion beam alignment and the associated measurement of current or current density for depth profiling in AES and XPS

1 Scope

This International Standard specifies methods for the alignment of the ion beam to ensure good depth resolution in sputter depth profiling and optimal cleaning of surfaces when using inert gas ions in Auger electron spectroscopy and X-ray photoelectron spectroscopy. These methods are of two types: one involves a Faraday cup to measure the ion current; the other involves imaging methods. The Faraday cup method also specifies the measurements of current density and current distributions in ion beams. The methods are applicable for ion guns with beams with a spot size below ~1 mm in diameter. The methods do not include depth resolution optimization.

2 Normative references

The following documents, in whole or in part, are normatively referenced in this document and are indispensable for its application. For dated references, only the edition cited applies. For undated references, the latest edition of the referenced document (including any amendments) applies

ISO 18115-1, *Surface chemical analysis — Vocabulary — Part 1: General terms and terms used in spectroscopy*

3 Terms, definitions, symbols and abbreviated terms

For the purposes of this document, the terms and definitions given in ISO 18115-1 and the following symbols and abbreviated terms apply.

<i>A</i>	Area of Faraday cup aperture
A_0	Area of ion beam raster in sample plane
A_R	Raster area at a known orientation to the ion beam
<i>B</i>	Ion beam broadening parameter equal to ratio I_{outer}/I_{inner}
<i>C</i>	Current
CD	Current density
D'	Ion dose rate at the sample
F'	Ion fluence rate delivered by ion gun
FC	Faraday cup
FWHM	Full width at the half maximum
<i>I</i>	Rastered ion beam current measured in aperture of Faraday cup
I_0	Stationary, small diameter ion beam current measured in aperture of Faraday cup
I_{inner}	Ion current measured at inner electrode of co-axial cup

I_{outer}	Ion current measured at outer electrode of co-axial cup
I_S	Beam current as measured into dark region in the method specified in 5.5
J	Current density in ion beam measured per unit area of sample surface
X	Position of ion beam on x-axis set by ion gun controller
X_0	Aligned position on x-axis of ion beam set by ion gun controller
Y	Position of ion beam on y-axis set by ion gun controller
Y_0	Aligned position on y-axis of ion beam set by ion gun controller
θ	Angle of incidence of ion beam with respect to sample surface normal
θ_a	Angle of incidence of ion beam with respect to Faraday cup surface normal in usual position
θ_b	Minimized angle of incidence of ion beam with respect to Faraday cup surface normal
AES	Auger electron spectroscopy
OMI	Optical microscope image
SEI	Secondary electron image
SEM	Secondary electron microscope
XPS	X-ray photoelectron spectroscopy

4 System requirements

4.1 General

This International Standard is applicable to the focusable ion gun for sputtering with inert gases that is usually supplied with most of AES and XPS instruments or available from after market suppliers. The beam size or raster area of the ion beam shall be larger than and uniform over the analysis area. Seven alternative methods of ion beam alignment are described that require the equipment to have provision for the measurement of the ion current, or for detecting excited secondary signals, or an optical microscope aligned at the analytical point. Depending on the equipment available, measurements of increasing sophistication may be made. The methods for measuring the ion beam current involve measurement by a circular-aperture Faraday cup, elliptical-aperture Faraday cup or a co-axial electrode cup. The methods involving the excited secondary signals are categorized by ion/electron-induced secondary electrons or emitted photons that are detected with a secondary electron detector, an optical microscope or a phosphor screen.

To conduct the relevant surface analysis, the electron energy analyser, the analysis probe beam and the ion beam need to be focused and aligned correctly on the same analysis point or area to be analysed. To apply this International Standard, the electron energy analyser and the analysis probe beam shall already be aligned to the optimum position using the manufacturer's or in house documented procedure.

4.2 Limitations

This International Standard is an important part of the setting up of depth profiling generally; nevertheless, depending on the material of the sample and its structure, there are several depth profiling

procedures that may be applied to achieve the best depth resolution, not all of which are aided by this International Standard. Some of the most popular procedures are

- a) ion bombardment of fixed position samples at angles of incidence in the range of 0°–60° with respect to the surface normal,
- b) ion bombardment at grazing angles of incidence,
- c) sample rotation during ion bombardment,
- d) simultaneous ion bombardment applying two ion guns, and
- e) sample rotation and grazing angle of incidence for ion bombardment.

This International Standard will assist in the use of procedure a). Some aspects may relate to the other procedures but further considerations may be required that are not necessarily included in this International Standard.

5 Ion beam alignment methods

5.1 General

This International Standard describes not all but seven simple methods for ion beam alignment, easily applied. These methods and a summary of their advantages are set out in [Table 1](#). Also indicated are which methods are best for ion beam current or current density measurement.

Each method has different advantages and requires different instrumental capabilities. The analyst needs to select the method based on requirements and equipment capabilities. Some issues depend on the raster size of the ion beam. A small raster is good, since little material is consumed or sputter deposited in the spectrometer. Additionally, for industrial samples, the material to be profiled may only occupy a small area. A very small raster is possible in AES where the electron beam is small and some users may deliberately use higher ion beam energies where ion beams tend to be better focused to obtain small sputtered areas with a faster sputtering rate. In these cases, and for systems with small-area XPS analysis, particular care needs to be taken with alignment. For broader ion beams, such as for some XPS instruments, the alignment accuracy may be more relaxed. If more than one method is suitable, tests with each will show which is most convenient for the sputtering conditions intended.

The effects of good and poor ion beam alignment in sputter depth profiling are illustrated in [Annex A](#).

General precautions are given in [5.2](#). If analysts wish to align the beam and measure the ion beam current or current density, or change the ion beam energy, they can choose one of the two methods that use a Faraday cup. The alignment methods specified in [5.3](#) and [5.4](#) are those using Faraday cups with a circular aperture and an elliptical aperture, respectively; whereas [Annex B](#) introduces a method using co-axial electrodes giving measurements proportional to the ion current or current density. If analysts wish to align the beam and not measure the ion current or current density, they can align the beam using images from secondary electrons or ions excited by ions or primary electrons, or an optical image, or by ion-induced luminescence, using the methods specified in [5.5](#), [5.6](#), [5.7](#) and [5.8](#), respectively. The method chosen depends on the capability and facility of the instrument used.

[Clause 6](#) describes when to conduct the ion beam alignment.

5.2 Important issues to be considered prior to ion beam alignment

5.2.1 For consistent, high quality analysis, the analytical probe beam, whether stationary or rastered over an area, and the electron energy analyser axis shall be aligned at the analysis position. The intersection of these two axes with the specimen surface shall also define the centre for the sputtered area for sputter depth profiling.

5.2.2 It is important that the analysis area be located in the central, uniform region of the ion beam irradiation area. This is shown in [Figure 1](#).^[4] It is useful to know the sputtering rate for the ion gun and sample as a function of sputtering parameters such as the ion beam energy, beam current, raster size, and so on or their equivalent instrumental control settings in order to choose the best settings for the alignment. The two most important aspects for the analyst are to ensure that, through alignment of the ion beam, the analysis area coincides with the central uniform region of the ion beam irradiation area and also that an appropriate ion beam current density and raster size can be set. Ion beam currents and current densities may be measured using a Faraday cup using the methods specified in [5.3](#) and [5.4](#), as summarized in [Table 1](#). Some design details and the accurate measurement of both electron and ion beam currents using Faraday cups are given in References [\[5\]](#) and [\[6\]](#).

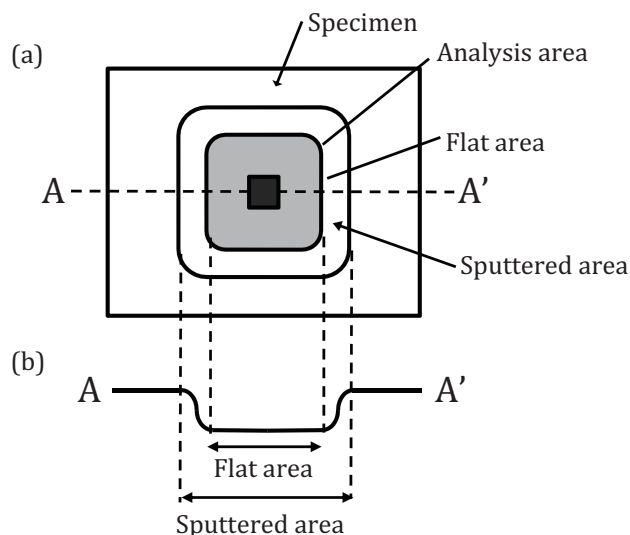

Figure 1 — Configuration of sputtered flat and analysis areas — (a) Top view (b) cross-section view along line A-A'^[4]

Table 1 — Detected signals when aligning ion beam — Summary of methods

Detected signal	Subclause: Method	Feature	Minimum ion energy ^a eV	Measurement of current and current density	Equipment required
Ion current	5.3: FC with circular aperture	Good for alignment. Gives the best measure of C and CD for quantitative sputtering rates but, for this, may require a FC that can be set normal to the ion beam at the analytical position. If the FC is in the sample plane, CD measurement may be poor at incidence angles greater than that for which the FC is designed, often ~45°.	~50	C: good CD: good	FC may be orientated towards the ion gun or in the sample plane.
	5.4: FC with elliptical aperture	Good for alignment. This modification can allow greater angles to be used than those given by 5.3.	~50	C: good CD: good	FC with elliptical aperture may be orientated towards the ion gun or in the sample plane.
Excited secondary signal	5.5: Ion-induced secondary electrons	Allows rastered ion beam to be aligned to within a fraction of the beam size, and the raster size to be determined but quantitative C and CD measurements are poor or must be conducted separately.	~50	C: poor CD: poor	Raster for ion beam
	5.6: Ion-induced secondary emission imaging	Allows unrastered ion beam to be aligned to within a fraction of the beam size but quantitative C and CD measurements are poor or must be conducted separately.	~50	C: poor CD: poor	Imaging for secondary electrons or ions
	5.7: Ion spot image in SEI or OMI	Allows an unscanned ion beam to be focused and aligned in a system with i) an electron beam raster either during d) or after a) sputtering or ii) an optical microscope after a) sputtering. C and CD measurements must be conducted separately. After sputtering methods are very slow.	~2 000 [i, d] ~50 [i, a] ~1 000 [ii, a]	C: no CD: poor	Raster for electron beam or optical microscope aligned at analytical point
	5.8: Ion-induced luminescence	Allows an unscanned ion beam to be focused and aligned in a system but the ion beam energy range available is limited. C and CD measurements must be conducted separately. Most, if not all, phosphorescent materials are also electrical insulators and not stable under irradiation from either ions or electrons.	~2 000	C: no CD: no	Phosphor screen for ion detection
C current CD current density FC Faraday cup ^a The minimum energy is the energy for which the beam size is below ~1 mm and which is rarely below 50 eV.					

5.2.3 In general, the components on the sample stage used in the methods given in this International Standard do not all lie in a single plane, for essential mechanical reasons, and this may cause errors in

alignment unless understood. [Figure 2](#) shows an example of the essential problem of using a screw head on the sample stage in an AES instrument when aligning the ion beam. If the region to be analysed is at a different height from the region used for setting the analytical position, an alignment error may occur. For both AES and XPS, the analyst needs a method to compensate for the different heights of any different components involved. Methods that have been used include optical or electron optical components with restricted depths of focus so that the item is only in focus to the monitoring microscope or the electron spectrometer, if at the correct position, or by stage adjustments for the known dimensions of these components.

5.2.4 When applying this International Standard, there shall be a manufacturer's or in-house documented procedure to set the sample at the correct analysis position and this shall be used whenever such setting is required.

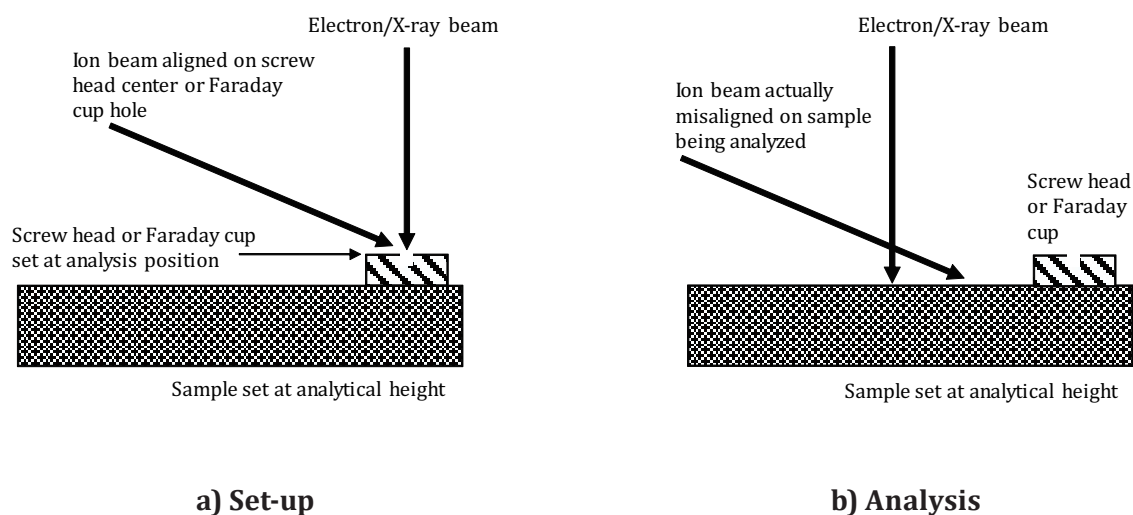

In a) the ion beam has been aligned to the screw head on the axis but is above the sample plane, and so, in b), when moving the sample to sputter an appropriate region without changing the height, the ion beam is misaligned.

Figure 2 — Diagram illustrating importance of aligning ion beam at component set at correct height

5.2.5 While aligning the ion beam, ensure that the samples to be analysed are not in a position where they can be sputtered or contaminated from ion-sputtered material while conducting this work.

5.3 Alignment using circular-aperture Faraday cup

5.3.1 The Faraday cup method is generally applicable in the ion energy range from below 50 to above 100 000 eV. A Faraday cup is shown in [Figure 3](#). Operate the Faraday cup according to the manufacturer's instructions. Turn off, or blank, the electron or X-ray beam. Turn off or blank any other items recommended by the manufacturer before using the ion beam. Set the centre of the Faraday cup at the analysis position. Turn on the ion beam with settings as close to those intended as is possible, without the ion beam raster.

NOTE 1 In many cases the defining aperture in the outer electrode of the Faraday cup is designed to be at the same height as the sample holder or a typical mounted wafer but this may or may not be the case in the instrument being used.

NOTE 2 If there is no instruction concerning the bias voltage to use on the inside of the Faraday cup, usually +15 V is found sufficient. A lower voltage may not stop most electrons being emitted and a higher voltage may enlarge the apparent aperture size.

5.3.2 If the Faraday cup aperture size is able to be selected, a size smaller than the ion beam allows the best alignment and current density measurement, but it should still be sufficiently large to accept sufficient current for adequate measurement by the current meter available. Apertures larger than at least twice the FWHM of the ion beam profile may be used to measure the total beam current.

NOTE Parameters of the Faraday cup design and applied voltages on both the outer shield and inner cup, important for accurate measurements, are described by References [5] and [6]. Accuracies better than 1 % may be achievable. For non-normally incident ions, care is required in considerations of the aperture edge and the depth and structure of the Faraday cup if measurement errors are to be avoided.

5.3.3 Adjust the ion beam X and Y position offsets and tune the voltages of the ion gun objective (final) lens until attaining a maximum current in the Faraday cup as shown in Figure 4. If a condenser lens is also available, increasing its voltage usually allows a smaller spot size to be obtained but with a lower beam current. After changing the condenser lens strength, the objective lens may need refocusing. Depending on the equipment available, this sequence may need to be repeated iteratively until final settings for beam size, position and current are attained. This provides the X_0 and Y_0 settings for the X and Y offsets for correct alignment for the given setting of the beam energy, lenses, etc.

NOTE If the ion beam is not at normal incidence to the sample or Faraday cup, the X and Y deflections may either give equal angular deflections for equal settings or one deflection may be scaled against the other to give equal deflections on the sample surface. It is useful to check this to understand the equipment behaviour. The apparent width of the Faraday cup aperture in the X and Y directions will be affected by these considerations.

5.3.4 If the beam width observed is greater than required, it may be possible to reduce it by reducing the beam current and checking the focus. Ion beams may exhibit an astigmatic focus. This can be checked by scanning over the Faraday cup in both X and Y directions, optimizing the focus each time, with the average focal setting being used. Ensure that the X and Y offsets are tuned last for the final operating condition to set X_0 and Y_0 .

Ion beam bombardment increases the emission of secondary electrons, and it may damage the secondary electron detector or electron energy analyser. Therefore, before switching on the ion beam, check if it is necessary to turn off or decrease both the voltages supplied to the electron multiplier detectors and any other radiation sensitive detector.

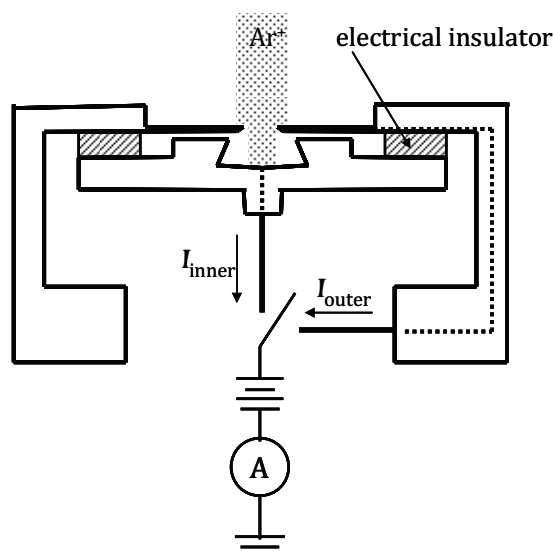
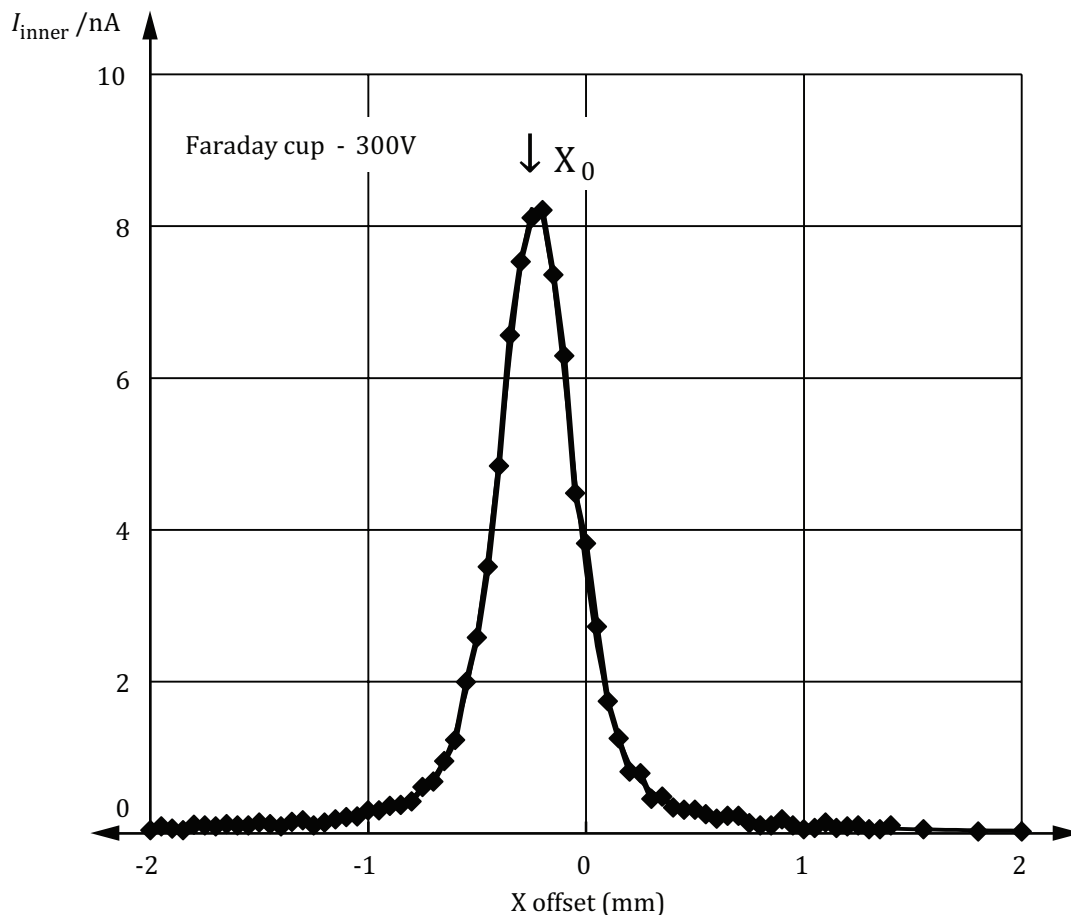

Figure 3 — Schematic of Faraday cup with design accepting ions up to 45° from its surface normal (modified from Reference [4])

5.3.5 This provides the X_0 and Y_0 settings for the X and Y offsets for correct alignment for the given setting of the beam energy, lens settings, etc. The values of X_0 and Y_0 are valid only for those settings and are likely to change if the settings are changed. Record these settings.

5.3.6 To measure the ion beam current or current density, it is necessary to check that the Faraday cup specification is valid for a beam entering at the angle of incidence from the surface normal, θ_a , relevant for the analysis position. If so, this position may be retained and 5.3.7 and 5.3.8 proceeded to. However, if this is not the case, the Faraday cup shall be orientated at an angle from the surface normal, θ_b , as small as possible before proceeding.



The Y-direction has been optimized at Y_0 and the position of X_0 indicated.

The Faraday cup aperture diameter is 200 μm .

Figure 4 — Example plot of ion current vs. X-direction offset for 300 eV ions at about 47° to circular aperture

5.3.7 If the measured beam profile achieved by scanning the beam across the Faraday cup is as shown in Figure 4, it is too broad to measure the beam current accurately. In this case, only the current density in the rastered mode is measurable. Set the raster running with all other ion beam settings kept constant and measure the current recorded into the Faraday cup. This requires current measurement with a sufficient integration time that the current is averaged over many raster frames. For the Faraday cup retained in the original analysis position, the ion beam current density per unit area of the surface, J , is given by the quotient of the measured ion beam current with the raster operational, I , and the Faraday cup aperture area, A :

$$J = \frac{I}{A} \quad (1)$$

For the Faraday cup orientated at an angle, θ_b , as close to normal to the ion beam axis as possible:

$$J = \frac{I \cos(\theta_a)}{A \cos(\theta_b)} \quad (2)$$

NOTE The integral of J with time gives the dose delivered to the sample. Had the sample and Faraday cup been set normal to the ion beam, the aperture area seen by the beam would be greater by the factor $\sec(\theta_a)$, compared with its tilted position, and the integral of J with time would then give the fluence in the beam and delivered to the sample. The ion gun delivers a certain fluence rate, F' , which is related to the delivered dose rate at the sample, D' , by $F' = D' \sec(\theta)$.

5.3.8 For the Faraday cup retained in the original analysis position, if the measured beam profile achieved by scanning the beam across the Faraday cup is not as shown in [Figure 4](#) but exhibits a flat plateau in the centre, the ion beam current may be measured as well as the current density described in [5.3.7](#). The ion beam current is given as the value, I_0 , at the centre of the plateau. This may be used to derive the value of the ion beam current density per unit area of the surface, J , if the raster area, A_0 , is known, or may be determined from Formula (3):

$$J = \frac{I_0}{A_0} \quad (3)$$

NOTE A modified method can be applicable in which ion current at the inner electrode and at the outer electrode of a co-axial electrode cup are measured independently, as introduced in [Annex B](#).

5.4 Alignment using elliptical-aperture Faraday cup

For this method, follow the procedure described in [5.3](#). This method is used where the Faraday cup is set in the sample plane and the major axis of the elliptical aperture is aligned to the ion beam azimuth. In this case, the ratio of the minor axis length to that of the major axis should be equal to $\cos(\theta_a)$, where θ_a is the ion beam angle of incidence from the Faraday cup surface normal. For a Faraday cup set in the sample plane, this provides an aperture more closely matched to the ion beam footprint on the sample, so that current and current density measurements may be made more easily.

5.5 Alignment using images from ion-induced secondary electrons during ion beam rastering

5.5.1 This method may be used when it is possible to raster the ion beam and when there is a secondary electron detector that can be used to provide an ion-induced SEI. A further requirement for this method is that the instrument be equipped with a raster-scanned and focused electron beam or optical microscope accurately aligned with, and focused upon, the analysis position of the spectrometer. This method has the advantage of defining, simultaneously, the sputtered area.

5.5.2 Before beginning to apply this method, the ion beam current and ion beam energy shall be set to the desired value by following the manufacturer's instructions or other documented procedure.

5.5.3 The ion gun shall be aligned using a sample having a feature that can be seen clearly both in the SEI or OMI and in an ion-induced SEI. The feature may be a hole or depression in the sample surface or an area of the sample having a different composition from the remainder of the sample.

A useful example of a sample with contrasting compositions is a transmission electron microscope grid of suitable pitch mounted on a stainless steel sample holder.

5.5.4 The sample shall be loaded into the instrument and the feature placed accurately in the analysis position of the spectrometer using the electron beam image or the optical microscope. The sample shall not be moved during the remainder of the alignment procedure.

NOTE If the feature is not at the same height as the sample to be studied later, this height change will need to be taken into account when aligning the sample.

5.5.5 The ion beam shall then be rastered over the sample under low magnification conditions (large rastered area) and the image produced from the secondary electron detector observed.

5.5.6 The ion beam shall then be focused until the clearest possible image of the feature on the sample is observed. The X and Y shifts on the ion gun shall then be adjusted to centralize the feature in the ion-induced SEI. During the process of centralising the feature, the magnification should be increased (rastered area decreased) as much as possible consistent with maintaining a clear view of the feature in the ion-induced SEI. Once the image is centralized, the beam focus shall be adjusted again to produce the clearest possible image. Once this method has been completed, the centre of the area rastered using the ion beam is to be aligned with the analysis position of the spectrometer. As many of the ion gun parameters as possible shall be recorded. An example of an ion-raster image is shown in [Figure 5](#).

NOTE In ion guns with two adjustable lenses, by strengthening the condenser lens and refocusing the objective lens, a sharper focus may be achieved, but often with a significant reduction in beam current. Equivalently, greater current may be achieved, weakening the condenser lens and degrading the beam size.

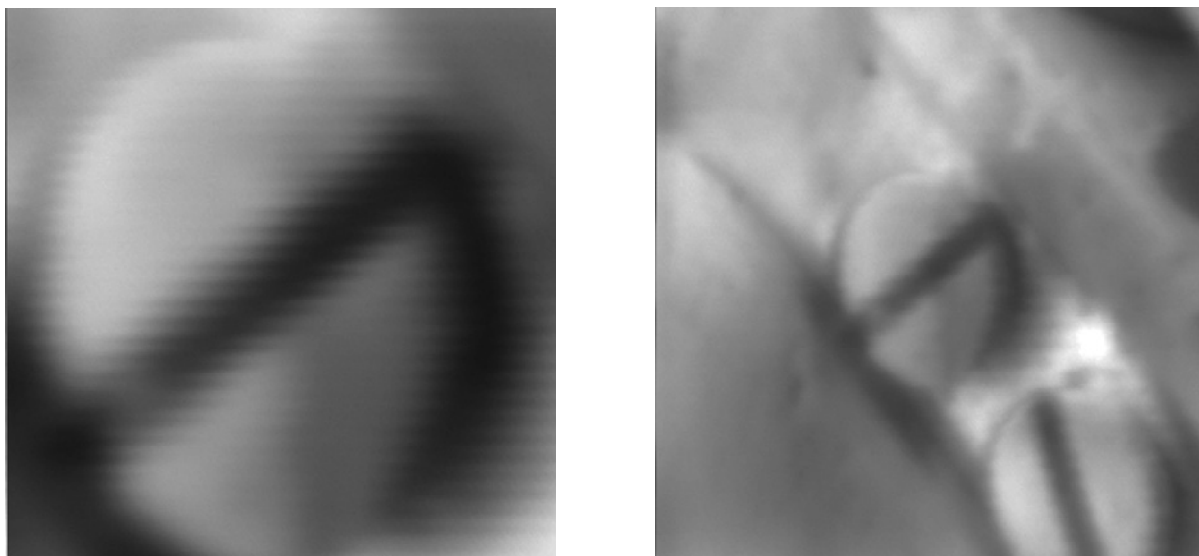

The image at left is an enlarged view.

Figure 5 — Ion raster TV-images of screw heads on sample stage at ion beam energy of 3 keV

5.5.7 If the image is unclear, increase the ion beam energy until a clear image is achieved, since the quality of the beam focus usually improves as the beam energy rises. Next, incrementally reduce the beam size and alter the focus conditions until either the required beam energy is achieved or the minimum beam energy for which an image is possible is attained. It may not be possible to use the ion gun effectively at lower beam energies than the latter setting. Centralize the feature to align the ion beam.

NOTE 1 Some experience may be necessary to judge the ion-raster image of an object because the viewing direction of the object is different between the optical microscope and the ion beam.

NOTE 2 Ion beam bombardment will increase the emission of secondary electrons, and may cause damage to electron multiplier detectors. Therefore, before starting ion beam irradiation, it may be necessary to turn off or decrease the voltages supplied to the detectors.

NOTE 3 This method is also applicable to ion current images from the Faraday cup current. This should allow good measure of scattered ion current outside the Faraday cup.

NOTE 4 Increasing beam energy in general degrades the depth resolution for depth profiling.

5.5.8 This provides the X_0 and Y_0 settings for the X and Y offsets for correct alignment for the given setting of the beam energy, lens settings, etc. X_0 and Y_0 are valid only for these settings and are likely to change if the settings are changed. Record these settings.

5.5.9 To measure the ion beam current approximately, use the sample stage shifts or the beam offset controls to steer the beam into the darkest region of the image such as the screw slot in [Figure 5](#). Collapse the raster so that the beam is stationary and measure the beam current, I_S . To measure the current density, J , determine the raster area, A_R , either from a sputtered crater or from the relevant image, as shown in [Figure 5](#); then $J = I_S/A_R$. If A_R is in the plane of the sample holder, then J is the current density per unit area of surface at that orientation.

NOTE The electron emission from materials bombarded by ions is low and so the error in I_S , without a bias voltage on the sample holder, is generally less than 10 %.

5.6 Alignment in X-ray photoelectron microscope/photoelectron imaging system

5.6.1 Check with the instrument manufacturer that this method is suitable for the instrument. It may be that the analyser or other items should not be operated at the same time as the ion gun. Under bombardment with ions, films of SiO_2 or Ta_2O_5 , around 100 nm thick, emit both electrons and negative oxygen ions. These are detected equally in electrostatic electron spectrometers. The negative particles have a very wide energy range, extending up to the energy of the incident ion beam, but peaking at a few electro volts and of diminishing intensity at higher energies. Set the spectrometer to detect at a coarse energy resolution, at 100 eV kinetic energy and at a high spatial resolution. Turn on the ion gun at a low current without any raster. The region struck by the ions may now be imaged using the emitted negative particles by the X-ray photoelectron microscope or photoelectron imaging system without the X-rays.

NOTE The energy spectra for the negative particles from Ta_2O_5 are illustrated by Reference [6].

5.6.2 If there is insufficient emission to create an image, increase the ion beam current to the operating setting. If there is still insufficient emission to create an image, reduce the analyser detection energy, if possible, until an image is obtained. Adjust the ion beam X and Y position offsets and tune the voltages of both the ion gun objective (final) lens, and any available condenser lens, until a suitable focus is achieved, centred on the analytical area. Depending on the equipment available, this sequence may need to be repeated iteratively until final settings are attained. This provides the X_0 and Y_0 settings for the X and Y offsets for correct alignment for the final settings of the beam energy, lens settings, etc. X_0 and Y_0 are valid only for these settings and are likely to change if the settings are changed. Record these settings.

NOTE In ion guns with two adjustable lenses, by strengthening the condenser lens and refocusing the objective lens, a sharper focus may be achieved, but often with a significant reduction in beam current. Equivalently, greater current may be achieved, weakening the condenser lens and degrading the beam size.

5.6.3 To measure the ion beam current approximately, use the current, I_S , from the sample stage. To measure the current density, J , determine the raster area, A_R , either from a sputtered crater or from the relevant image; then $J = I/A_R$. If A_R is in the plane of the sample holder, then J is the current density per unit are of surface at that orientation.

NOTE The electron emission from materials bombarded by ions is low and so here the error in I_S is often less than 20 %.

5.7 Alignment by observing direct ion beam spot or crater image during and/or after ion sputtering

5.7.1 A direct, unrastered, ion beam spot may be visible on certain samples by using the SEM mode in a scanning Auger microscope system during ion sputtering by adjusting both the ion and electron beam currents to be of similar magnitude. Films of SiO_2 or Ta_2O_5 , around 100 nm thick, are often used for this purpose. For use of the method during sputtering, the ion beam energy should be in the energy range 2 to 5 keV for a clear sputtered spot or area to be observed. For use of the method after sputtering, any beam energy may be used but iteration of parameters depends upon the film thickness. Alignment shall be achieved by adjusting the ion beam X and Y shifts to bring the ion beam spot or sputtered area to the centre of the secondary electron or optical image.

5.7.2 This provides the X_0 and Y_0 settings for the X and Y offsets for correct alignment for the given setting of the beam energy, lens settings, etc. X_0 and Y_0 are valid only for these settings and are likely to change if the settings are changed. Record these settings.

NOTE This method is described in Reference [4].

5.7.3 The alignment method is illustrated in Figure 6 with, as an example, an SiO_2 film, where a 3 keV primary electron beam is used to generate the secondary electron beam image. The dark ellipse corresponds to the ion beam. This method is not suitable for large diameter or low voltage ion beams since the contrast then becomes too weak to be effective.

5.7.4 When applying this method and profiling through the oxide layer with a SiO_2 or Ta_2O_5 thin films of known thickness, tabulated sputtering yields[7-10] may be used to deduce the ion current density.

NOTE The times to sputter through other materials may be deduced from their sputtering yields.[11]

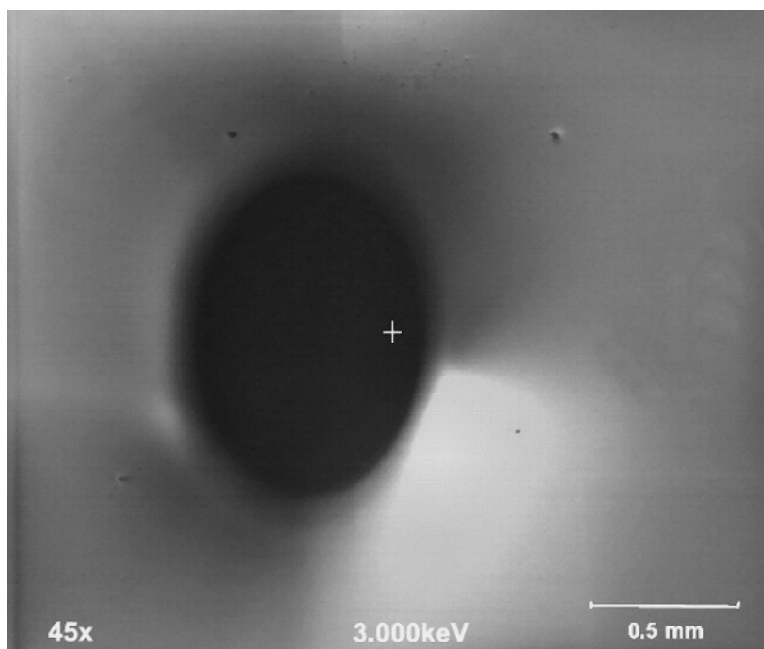

The electron beam is incident at 45° and the ion beam is misaligned to the left by 0,4 mm.[4]

Figure 6 — Alignment using SiO_2 film and method given in 5.7 using tatic ion beam of approx. 1 mm diameter and rastered electron beam

5.8 Alignment by observing phosphor sample

5.8.1 In this method a suitable phosphor-coated sample¹⁾ that emits visible light under ion impact without degradation is placed at the correct analytical position. The ion beam is then set with nominal conditions as close as possible to those required and the phosphor screen emission is viewed through the sample positioning optical microscope. The ion beam X and Y shifts are then set to bring the ion beam spot seen on the phosphor screen to the alignment centre of the optical microscope.

5.8.2 This provides the X_0 and Y_0 settings for the X and Y offsets for correct alignment for the given setting of the beam energy, lens settings, etc. X_0 and Y_0 are valid only for these settings and are likely to change if the settings are changed. Record these settings.

A colour monitor is recommended for observing the ion beam spot since that provides better discrimination of the light.

Care needs to be taken in selecting a phosphor with high light output and low ion damage. Care should also be taken to ensure the phosphors do not charge under irradiation from either the electron or ion beam.

6 When to align and check ion beam alignment

6.1 The first time that this International Standard is used, a depth profile shall be made on a material whose interface width is known from the published literature or from independent studies. This result shall then be compared with the result obtained to see if it is adequate for the purpose required. If not, the ion beam alignment shall be confirmed and the main functions of the instrument checked to be within specification. If the depth profile resolution is still too poor, check that the correct sample is being used and then try another lower or higher beam energy. If the depth resolution is still too poor, contact the instrument manufacturer for their recommendations.

NOTE If the material to be sputtered is an insulator, take appropriate action (e.g. use an electron flood gun and/or low energy ion source) to avoid surface charging.

6.2 Appropriate samples for depth profiling are the Ta_2O_5 and SiO_2 described in [5.7.1](#) and multilayered samples described in ISO 14606.

6.3 Ion beam alignment is recommended after the instrument installation, after changing the ion gun filament or any of the ion gun parameters, after a system bake-out, after moving items such as the electron energy analyser and/or probe source, and so on. Ion beam alignment is recommended if the depth resolution or sputter rate consistency is not as good as desired or usually experienced.

1) Suitable phosphor screen samples are available from TMS Vacuum Components (<http://www.tmsvacuumcomponents.co.uk/>), Unit 21 Stirling Road, Castleham Industrial Estate, Hastings, East Sussex, TN38 9NP, UK. This information is given for the convenience of users of this document and does not constitute an endorsement by ISO of this product.

Annex A (informative)

Comparison of AES depth profiles with good/poor ion beam alignment

An example of depth profiles of a GaAs/AlAs superlattice illustrates the effect of poor ion beam alignment. In [Figure A.1](#), a) shows a consistent, high quality profile for a rastered aligned ion beam and b) the result obtained intentionally at the crater edge of the rastered area shown in [Figure 1](#). Sputtering was carried out by 1 keV Ar⁺ ions without sample rotation during sputtering at an the incident angle of 45° with a raster area of 1,5 mm × 1,5 mm and an analysis area of 50 μm × 57,7 μm, both measured on the sample surface. Both depth profiles are almost the same distance to the surface; however, at greater depths the degradation in the depth resolution and the loss of the maximum intensities is clear for the poorly aligned case. The sputtering times from the outermost surface to the substrate were 25 min and 39 min, respectively. The sputtering rate was about 36 % less for the poorly aligned depth profile obtained at the crater edge than that for well-aligned profile at the centre of the crater.

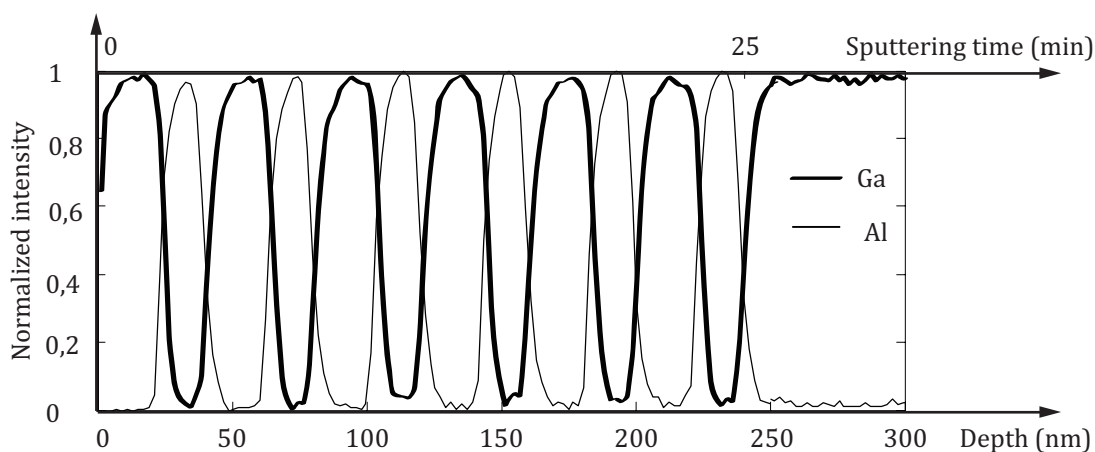

a) Good ion beam alignment

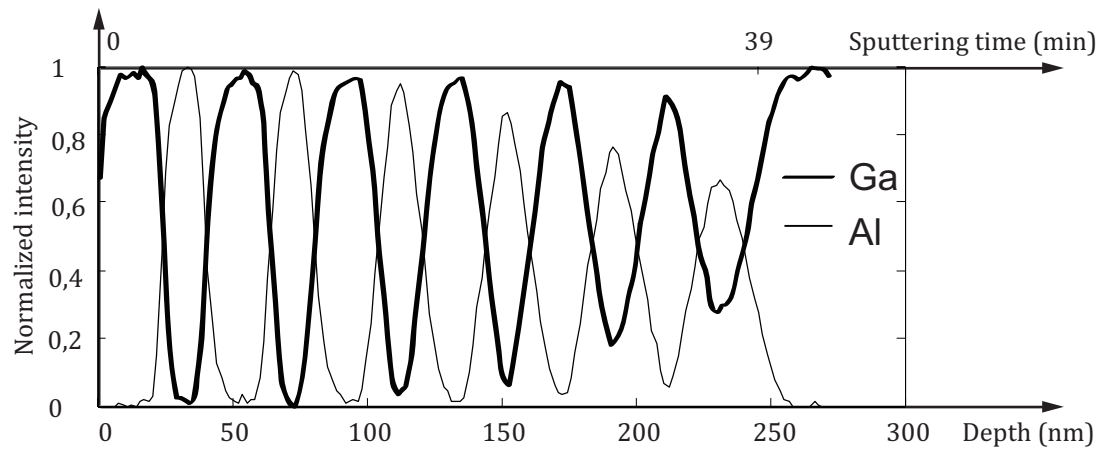

b) Poor ion beam alignment

Figure A.1 — Comparison of AES depth profiles of GaAs/AlAs superlattice^[4]

Annex B (informative)

Alignment using cup with co-axial electrodes

B.1 In this method, the ion currents at the inner, I_{inner} , and at the outer electrodes, I_{outer} , of a co-axial electrode cup [see [Figure B.1 a\)](#)] are measured independently. The order of the magnitude of the size of the top plane of the inner electrode is within the range of 1/10 to 2 of the ion beam size. The best operation is achieved when the size of the inner electrode is comparable with the ion beam size. A beam broadening parameter, B , is defined as I_{outer}/I_{inner} . Alignment and focusing of the ion beam is achieved by adjusting the X and Y beam deflectors and the focus lens in the sequence described at [5.3.3](#), taking into account [5.3.4](#), to obtain the minimum value of B .

B.2 For an ion beam current density with a defined distribution, the dependence of B on the X and Y settings may be modelled and the beam spot size given by the full width at half maximum roughly evaluated as shown in [Figure B.1 b\)](#).

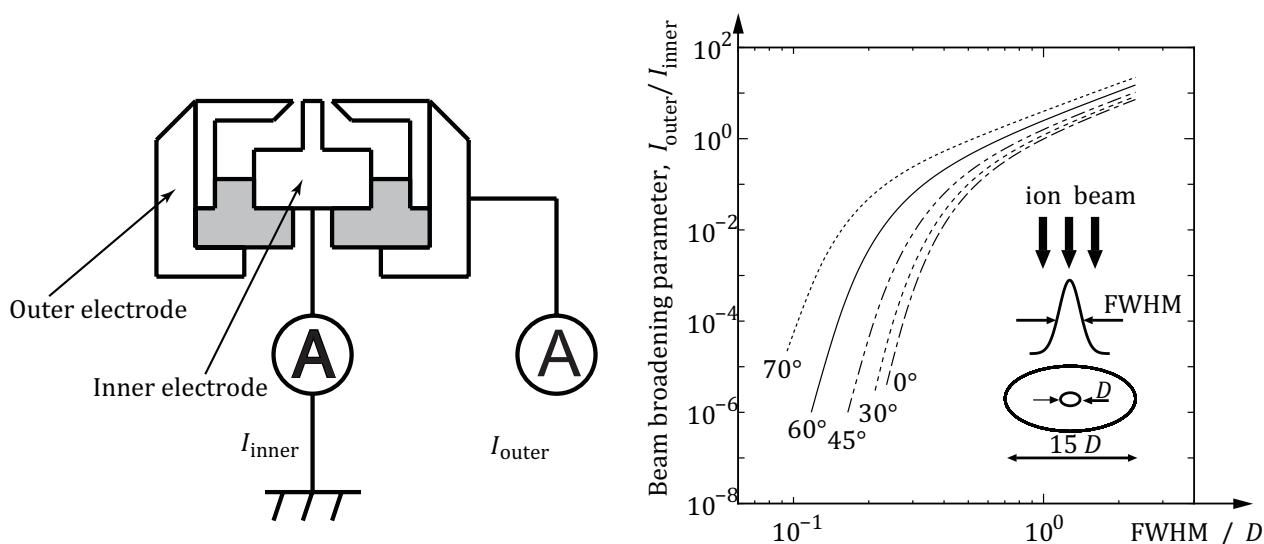

a) Schematic diagram of co-axial electrode Faraday cup

b) Simulated relationship between B and FWHM of ion beam^[12] as function of FWHM of Gaussian profile for several angles of incidence

Key

D diameter of outer electrode aperture

Figure B.1 — Method of alignment using cup with co-axial electrodes

When the inner and outer electrodes are made of the same material, parameter B directly provides the FWHM of the ion beam under the assumed beam profile of such as a Gaussian and Lorentzian profiles. In the case that the materials of the electrodes are different, the correction for the ion-induced secondary electron is required to obtain an accurate value of the FWHM of the ion beam profile.

Using a circular aperture FC as shown in [Figure 3](#), an ion beam can be aligned using a similar procedure by adjusting the current ratio. It is easy to carry out this method when the diameter of ion beam diameter is almost same as that of FC aperture. In the case that the FWHM of the ion beam profile is deduced from the current ratio it is needed to compensate the current obtained at the outer electrode by secondary electron yields.

Bibliography

- [1] ISO 14606:2000, *Surface chemical analysis — Sputter depth profiling — Optimization using layered systems as reference materials*
- [2] BARNA A., RADNÓCZI G., PÉCZ B. Sample Preparation Techniques for TEM, in Handbook for Microscopy, vol. 3./Applications: II. Special Topics ed. by S. Amelickx et al, (VCH Verlagsgesellschaft mbH, Weinheim, Germany). 1997, Chapter 3. pp: 751–801
- [3] MENYHARD M. High Depth-Resolution Auger Depth Profiling/Ion Mixing. *Micron*. 1999, **30** pp. 255–265
- [4] URUSHIHARA N., SANADA N., PAUL D., SUZUKI M. Ion Beam Alignment Procedures using a Faraday Cup or a Silicon Dioxide Film on Silicon Substrate with Auger Electron Microscope. *J. Surf. Anal.* 2007, **14** (2) pp. 124–130
- [5] INGRAM G.D. SEAH, M.P. Model calculations of the electron-optical properties of compact Faraday cups. *J. Phys. E Sci. Instrum.* 1989, **22** (4) pp. 242–249
- [6] GILMORE I.S., & SEAH M.P. Fluence, Flux, Current and Current Density Measurement in Faraday Cups for Surface Analysis. *Surf. Interface Anal.* 1995, **23** (4) pp. 248–258
- [7] SEAH M.P., SPENCER S.J., GILMORE I.S., JOHNSTONE J.E. Depth resolution in sputter depth profiling—characterization of a third batch of tantalum pentoxide on tantalum certified reference material by AES and SIMS. *Surf. Interface Anal.* 2000, **29** (1) pp. 73–81
- [8] SEAH M.P., & NUNNEY T.S. Sputtering Yields of Compounds Using Argon. *J. Physics D: Applied Physics*, 2010, **43** (25), pp. 253001 (13 pages)
- [9] SEAH M.P., & HUNT C.P. Characterisation of High Depth Resolution Tantalum Pentoxide Sputter Profiling Reference Material. *Surf. Interface Anal.* 1983, **5** (5) pp. 199–209
- [10] SEAH M.P., & HUNT C.P. Atomic Mixing and Electron Range Effects in Ultra High Resolution Profiles of the Ta/Ta₂O₅ Interface by Argon Sputtering with AES. *J. Appl. Phys.* 1984, **56** (7) pp. 2106–2113
- [11] VEISFELD N., & GELLER J.D. Sputtering Yield Measurements for submicrometer Thin Films. *J. Vac. Sci. Technol. A*. 1988, **6** (3) pp. 2077–2081
- [12] INOUE M., KURAHASHI K., KODAMA K. Focusing and Positioning of Ion Beam for Sputter Depth Profiling using a Coaxial Sample Stage and a Dual Nano-ammeter [in Japanese]. *J. Surf. Anal.* 2003, **10** (3) pp. 197–202

British Standards Institution (BSI)

BSI is the national body responsible for preparing British Standards and other standards-related publications, information and services.

BSI is incorporated by Royal Charter. British Standards and other standardization products are published by BSI Standards Limited.

About us

We bring together business, industry, government, consumers, innovators and others to shape their combined experience and expertise into standards-based solutions.

The knowledge embodied in our standards has been carefully assembled in a dependable format and refined through our open consultation process. Organizations of all sizes and across all sectors choose standards to help them achieve their goals.

Information on standards

We can provide you with the knowledge that your organization needs to succeed. Find out more about British Standards by visiting our website at bsigroup.com/standards or contacting our Customer Services team or Knowledge Centre.

Buying standards

You can buy and download PDF versions of BSI publications, including British and adopted European and international standards, through our website at bsigroup.com/shop, where hard copies can also be purchased.

If you need international and foreign standards from other Standards Development Organizations, hard copies can be ordered from our Customer Services team.

Subscriptions

Our range of subscription services are designed to make using standards easier for you. For further information on our subscription products go to bsigroup.com/subscriptions.

With **British Standards Online (BSOL)** you'll have instant access to over 55,000 British and adopted European and international standards from your desktop. It's available 24/7 and is refreshed daily so you'll always be up to date.

You can keep in touch with standards developments and receive substantial discounts on the purchase price of standards, both in single copy and subscription format, by becoming a **BSI Subscribing Member**.

PLUS is an updating service exclusive to BSI Subscribing Members. You will automatically receive the latest hard copy of your standards when they're revised or replaced.

To find out more about becoming a BSI Subscribing Member and the benefits of membership, please visit bsigroup.com/shop.

With a **Multi-User Network Licence (MUNL)** you are able to host standards publications on your intranet. Licences can cover as few or as many users as you wish. With updates supplied as soon as they're available, you can be sure your documentation is current. For further information, email bsmusales@bsigroup.com.

BSI Group Headquarters

389 Chiswick High Road London W4 4AL UK

Revisions

Our British Standards and other publications are updated by amendment or revision.

We continually improve the quality of our products and services to benefit your business. If you find an inaccuracy or ambiguity within a British Standard or other BSI publication please inform the Knowledge Centre.

Copyright

All the data, software and documentation set out in all British Standards and other BSI publications are the property of and copyrighted by BSI, or some person or entity that owns copyright in the information used (such as the international standardization bodies) and has formally licensed such information to BSI for commercial publication and use. Except as permitted under the Copyright, Designs and Patents Act 1988 no extract may be reproduced, stored in a retrieval system or transmitted in any form or by any means – electronic, photocopying, recording or otherwise – without prior written permission from BSI. Details and advice can be obtained from the Copyright & Licensing Department.

Useful Contacts:

Customer Services

Tel: +44 845 086 9001

Email (orders): orders@bsigroup.com

Email (enquiries): cservices@bsigroup.com

Subscriptions

Tel: +44 845 086 9001

Email: subscriptions@bsigroup.com

Knowledge Centre

Tel: +44 20 8996 7004

Email: knowledgecentre@bsigroup.com

Copyright & Licensing

Tel: +44 20 8996 7070

Email: copyright@bsigroup.com



...making excellence a habit.™