

BS ISO 16468:2015



BSI Standards Publication

Investment castings (steel, nickel alloys and cobalt alloys) — General technical requirements

bsi.

...making excellence a habit.™

National foreword

This British Standard is the UK implementation of ISO 16468:2015. It supersedes BS ISO 16468:2005 which is withdrawn.

The UK participation in its preparation was entrusted to Technical Committee ISE/111, Steel Castings and Forgings.

A list of organizations represented on this committee can be obtained on request to its secretary.

This publication does not purport to include all the necessary provisions of a contract. Users are responsible for its correct application.

© The British Standards Institution 2015.

Published by BSI Standards Limited 2015

ISBN 978 0 580 76505 6

ICS 77.140.80

Compliance with a British Standard cannot confer immunity from legal obligations.

This British Standard was published under the authority of the Standards Policy and Strategy Committee on 31 October 2015.

Amendments/corrigenda issued since publication

Date	Text affected
------	---------------

INTERNATIONAL
STANDARD

BS ISO 16468:2015

ISO
16468

Second edition
2015-10-01

**Investment castings (steel, nickel
alloys and cobalt alloys) — General
technical requirements**

*Pièces moulées en cire perdue (acier, alliages de nickel et alliages de
cobalt) — Exigences techniques générales*



Reference number
ISO 16468:2015(E)

© ISO 2015



COPYRIGHT PROTECTED DOCUMENT

© ISO 2015, Published in Switzerland

All rights reserved. Unless otherwise specified, no part of this publication may be reproduced or utilized otherwise in any form or by any means, electronic or mechanical, including photocopying, or posting on the internet or an intranet, without prior written permission. Permission can be requested from either ISO at the address below or ISO's member body in the country of the requester.

ISO copyright office
Ch. de Blandonnet 8 • CP 401
CH-1214 Vernier, Geneva, Switzerland
Tel. +41 22 749 01 11
Fax +41 22 749 09 47
copyright@iso.org
www.iso.org

Contents

Page

Foreword	iv
1 Scope	1
2 Normative references	1
3 Terms and definitions	1
4 Materials and manufacture	2
4.1 Melting process.....	2
4.2 Remelting process.....	2
5 Inspection and testing	2
5.1 General requirements.....	2
5.2 Sampling.....	2
6 Retests	8
7 Cleaning and dressing	8
8 Quality	8
9 Production welds	8
10 Supplementary requirements	8
10.1 General.....	8
10.2 Agreed manufacturing procedure.....	8
10.3 Magnetic particle inspection.....	8
10.4 Radiographic inspection.....	8
10.5 Liquid penetrant inspection.....	9
10.6 Ultrasonic inspection.....	9
10.7 Inspection of weld preparation.....	9
10.8 Prior agreement relating to major finishing welds.....	9
10.9 Impact test at low temperatures.....	9
10.10 Hardness test.....	9
10.10.1 Brinell.....	9
10.10.2 Rockwell.....	9
10.10.3 Vickers.....	9
10.11 Specified ferrite range in austenitic and austenitic ferritic stainless steels.....	9
10.12 Unspecified elements.....	10
10.13 Test material removed from castings.....	10
10.14 Tensile test blocks and specimen locations for castings.....	10
10.15 Weld maps (sketches).....	10
10.16 Chemical analysis — Testing frequency.....	10
10.17 Tensile test — Testing frequency.....	10
10.18 Inspection documents.....	10
10.19 Marking.....	10
10.20 Decarburization.....	10
10.21 Metallurgical cleanliness.....	10
Bibliography	12

Foreword

ISO (the International Organization for Standardization) is a worldwide federation of national standards bodies (ISO member bodies). The work of preparing International Standards is normally carried out through ISO technical committees. Each member body interested in a subject for which a technical committee has been established has the right to be represented on that committee. International organizations, governmental and non-governmental, in liaison with ISO, also take part in the work. ISO collaborates closely with the International Electrotechnical Commission (IEC) on all matters of electrotechnical standardization.

The procedures used to develop this document and those intended for its further maintenance are described in the ISO/IEC Directives, Part 1. In particular the different approval criteria needed for the different types of ISO documents should be noted. This document was drafted in accordance with the editorial rules of the ISO/IEC Directives, Part 2 (see www.iso.org/directives).

Attention is drawn to the possibility that some of the elements of this document may be the subject of patent rights. ISO shall not be held responsible for identifying any or all such patent rights. Details of any patent rights identified during the development of the document will be in the Introduction and/or on the ISO list of patent declarations received (see www.iso.org/patents).

Any trade name used in this document is information given for the convenience of users and does not constitute an endorsement.

For an explanation on the meaning of ISO specific terms and expressions related to conformity assessment, as well as information about ISO's adherence to the WTO principles in the Technical Barriers to Trade (TBT) see the following URL: [Foreword - Supplementary information](#)

The committee responsible for this document is ISO/TC 17, *Steel*, Subcommittee SC 11, *Steel castings*.

This second edition replaces the first edition (ISO 16468:2005), which has been technically revised with the following changes:

- [Clause 2](#), two standards added;
- [3.3](#), revised;
- 3.4, deleted;
- [10.6](#), reference made to ISO 4992-1 and ISO 4992-2.

Investment castings (steel, nickel alloys and cobalt alloys) — General technical requirements

1 Scope

This International Standard specifies technical requirements for castings (steel, nickel alloys, and cobalt alloys) produced by the investment-casting process. The International Standards specifying metallurgical material requirements for steel, nickel alloy, and cobalt alloy casting grades are listed in the Bibliography.

The requirements stated in this International Standard form an integral part of the material specification. In cases of conflict, the requirements of this specification take precedence over the individual material specification requirements.

2 Normative references

The following documents, in whole or in part, are normatively referenced in this document and are indispensable for its application. For dated references, only the edition cited applies. For undated references, the latest edition of the referenced document (including any amendments) applies.

ISO 4986, *Steel castings — Magnetic particle inspection*

ISO 4987, *Steel castings — Liquid penetrant inspection*

ISO 4990, *Steel castings — General technical delivery requirements*

ISO 4992-1, *Steel castings — Ultrasonic examination — Part 1: Steel castings for general purposes*

ISO 4992-2, *Steel castings — Ultrasonic examination — Part 2: Steel castings for highly stressed components*

ISO 4993, *Steel castings — Radiographic inspection*

ISO 6506-1, *Metallic materials — Brinell hardness test — Part 1: Test method*

ISO 6507-1, *Metallic materials — Vickers hardness test — Part 1: Test method*

ISO 6508-1, *Metallic materials — Rockwell hardness test — Part 1: Test method (scales A, B, C, D, E, F, G, H, K, N, T)*

ISO 10474, *Steel and steel products — Inspection documents*

ISO 11970, *Specification and approval of welding procedures for production welding of steel castings*

ISO 13520, *Determination of ferrite content in austenitic stainless steel castings*

3 Terms and definitions

For the purposes of this document, the following terms and definitions apply.

3.1

primary heat

master

mother heat

melt

quantity of metal processed in a single furnace or refining vessel at one time, in such a manner, as to produce the desired composition and properties

3.2
sub-heat
melt
production heat
daughter heat

portion of a primary heat remelted for pouring into castings

3.3
investment casting
lost wax casting

metal casting that is produced in a ceramic shell or mould using an expendable pattern

Note 1 to entry: The expendable pattern may consist of wax, plastics, or other material, and is removed prior to filling the mould with liquid metal.

4 Materials and manufacture

4.1 Melting process

Primary heats shall be made by the electric furnace process, with or without separate refining, such as argon-oxygen-decarburization (AOD), vacuum-oxygen-decarburization (VOD), vacuum-induction-melting (VIM), etc., unless otherwise specified in the individual specification or agreed upon between the purchaser and manufacturer. Primary heats may be used directly for producing castings or converted into ingot, bar, shot, or other suitable form, for later remelting as a sub-heat.

4.2 Remelting process

Sub-heats shall be produced from primary-heat metal in suitable batch sizes by an electric induction furnace, with or without atmosphere protection, such as vacuum or inert gas, unless otherwise specified in the individual specification or agreed upon between the purchaser and manufacturer. Revert (gates, sprues, risers, and rejected castings) shall not be remelted except in primary heats. Additions of up to 5 %, by mass, are permitted for compositional adjustments and deoxidation.

5 Inspection and testing

5.1 General requirements

The general requirements for inspection and testing shall be in accordance with ISO 4990, except as described in [5.2](#).

5.2 Sampling

5.2.1 If castings are poured directly from one or more primary heats, then the samples for chemical and other required testing shall also be poured directly from each of the primary heats.

5.2.2 Unless otherwise specified by the purchaser, test blocks may be taken from castings, may be cast integrally with the castings, or may be cast in separate moulds of the same type and materials as those used for the castings. Samples for the determination of the chemical composition may be cast in other types of mould.

5.2.3 If castings are poured from a sub-heat, then the samples for chemical and other required tests shall also be poured from a sub-heat of the same primary melt, but not necessarily from the same sub-melt as the castings. The sub-melt used for the test samples shall be produced using the same practices and additions as used for the castings.

5.2.4 Examples of test blocks which may be used for mechanical testing are shown in Figure 1, except when 10.14 is specified. The test block in Figure 1 d) may be employed only for austenitic alloy castings with a ruling thickness less than 65 mm.

Dimensions in millimetres

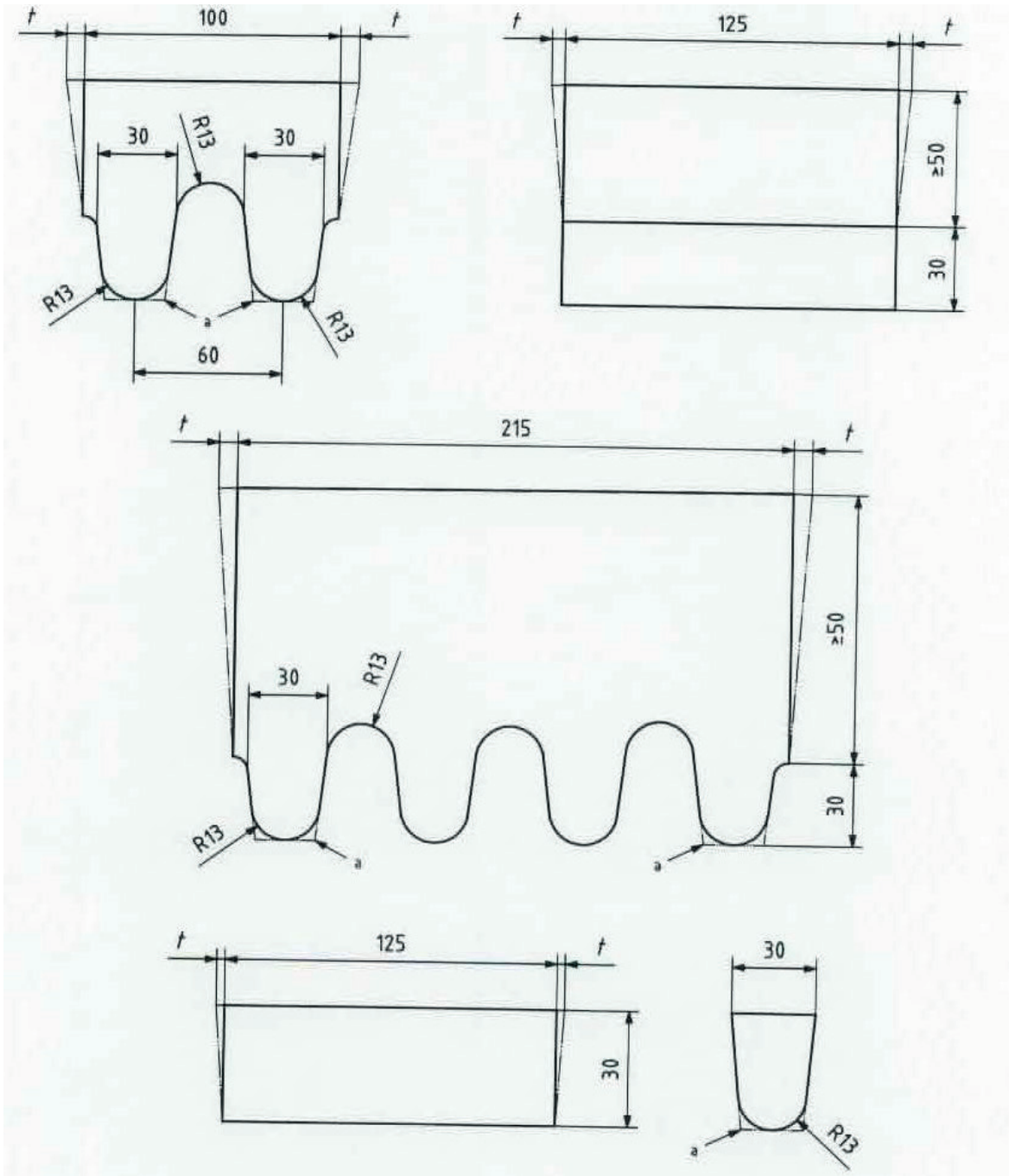

a)

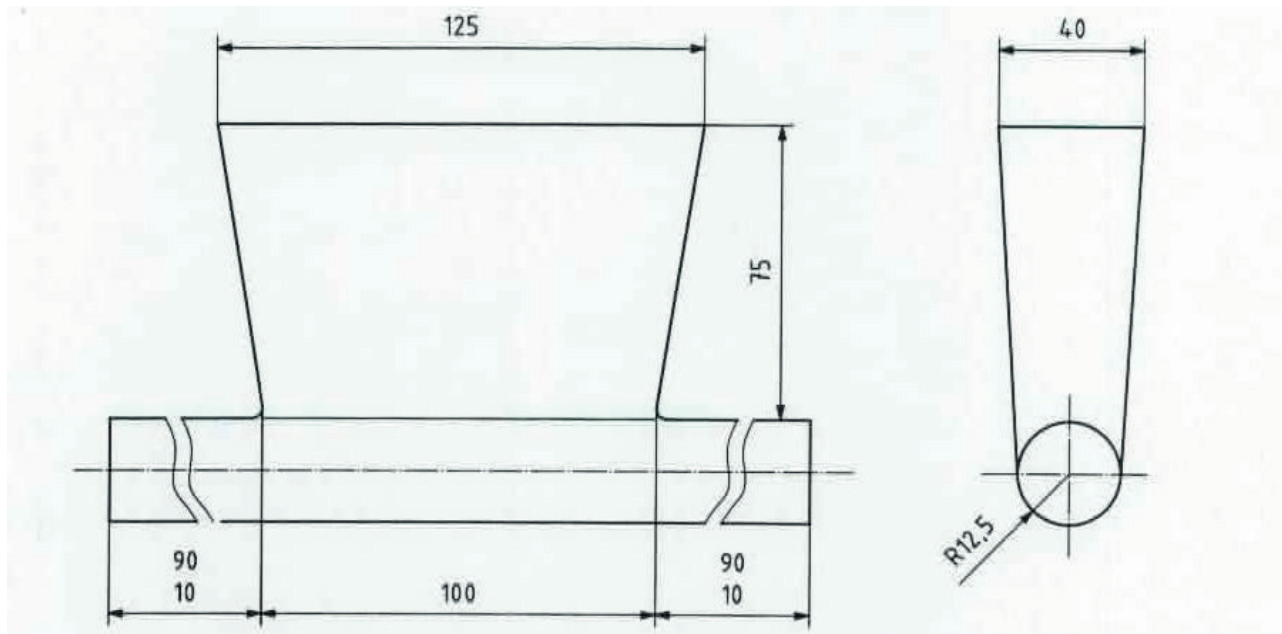

b)

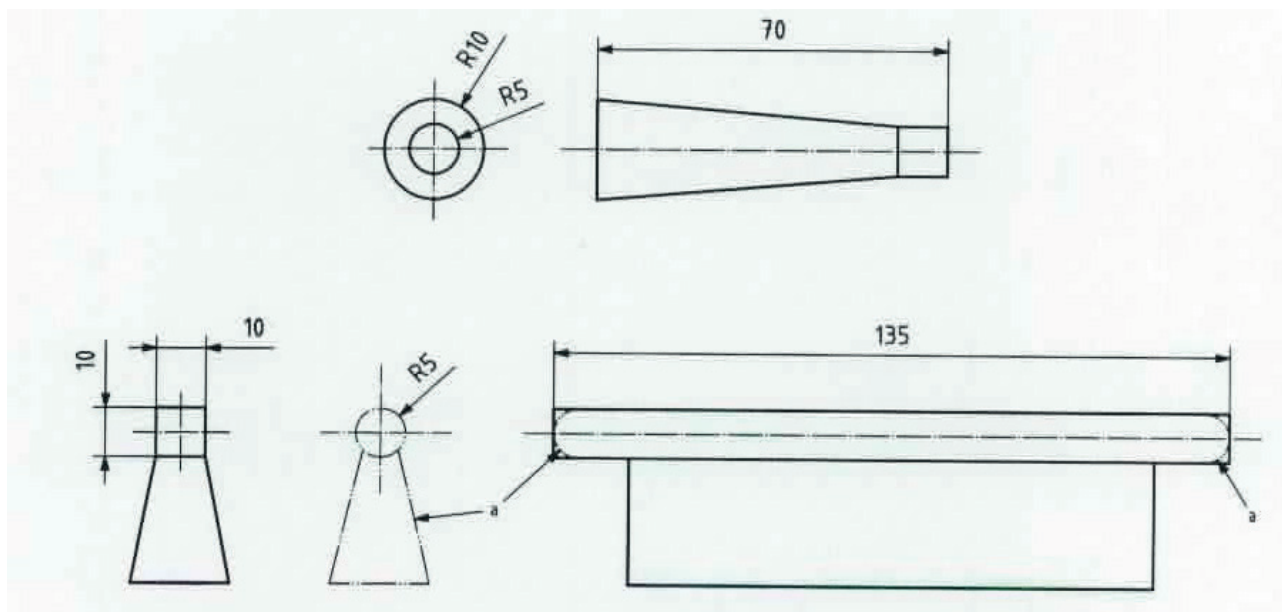

c)

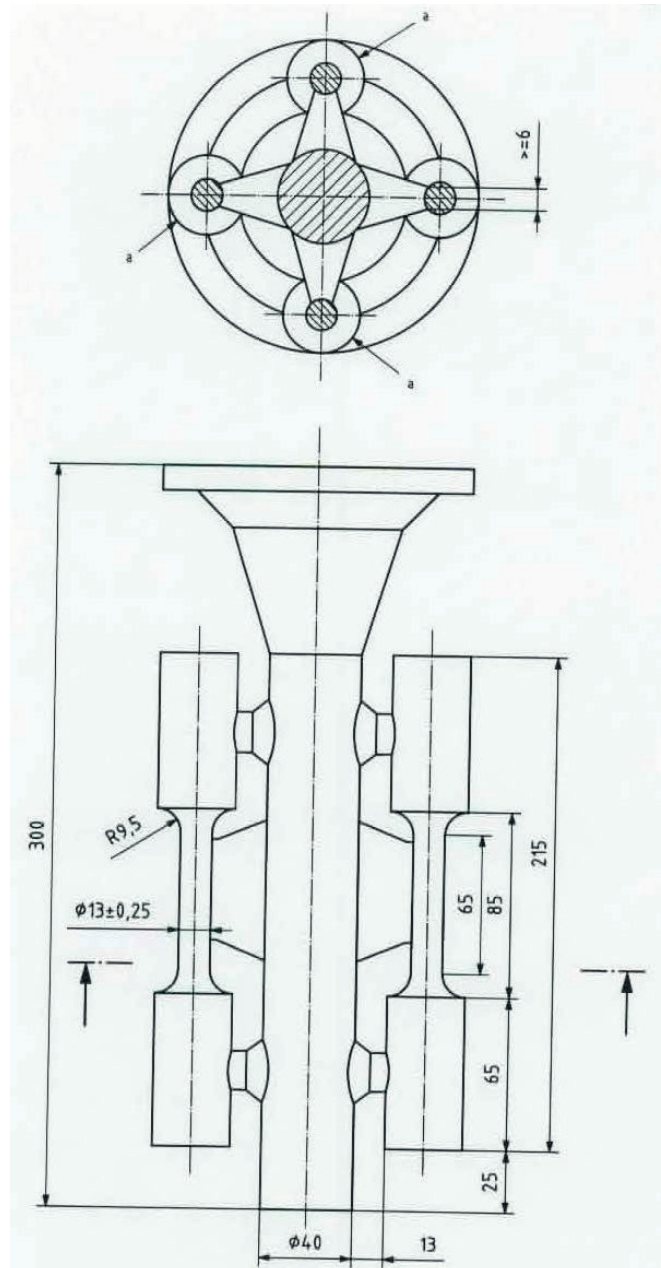

d)

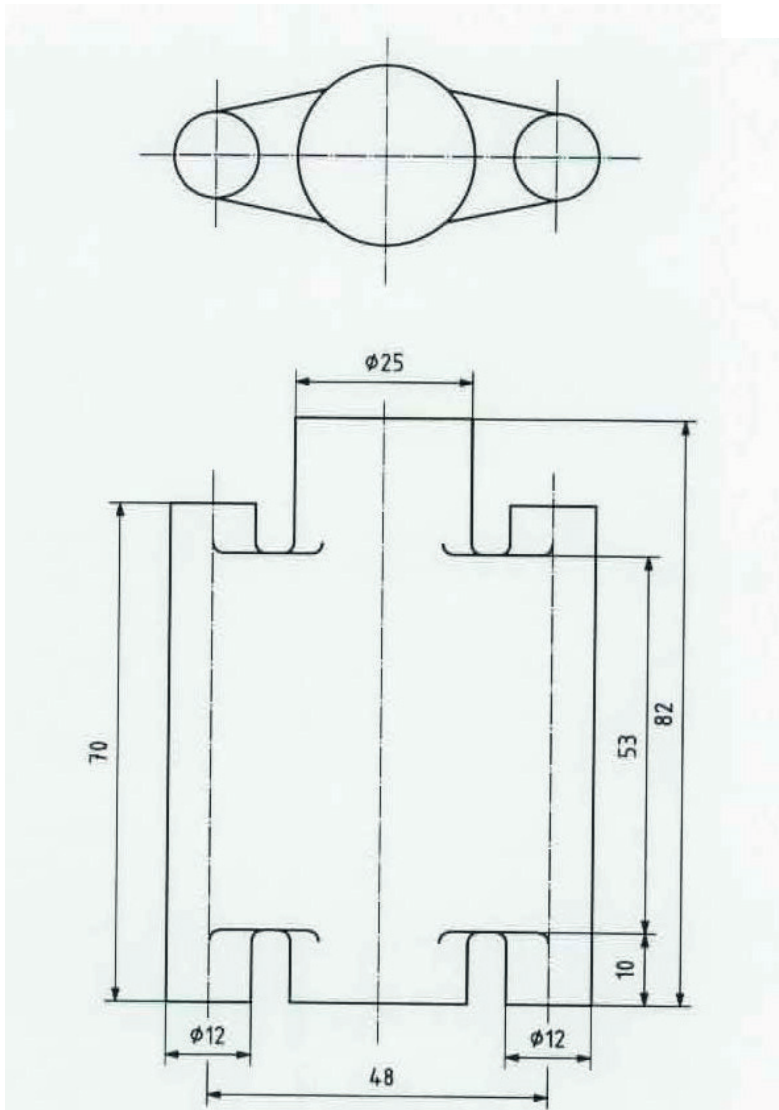

e)

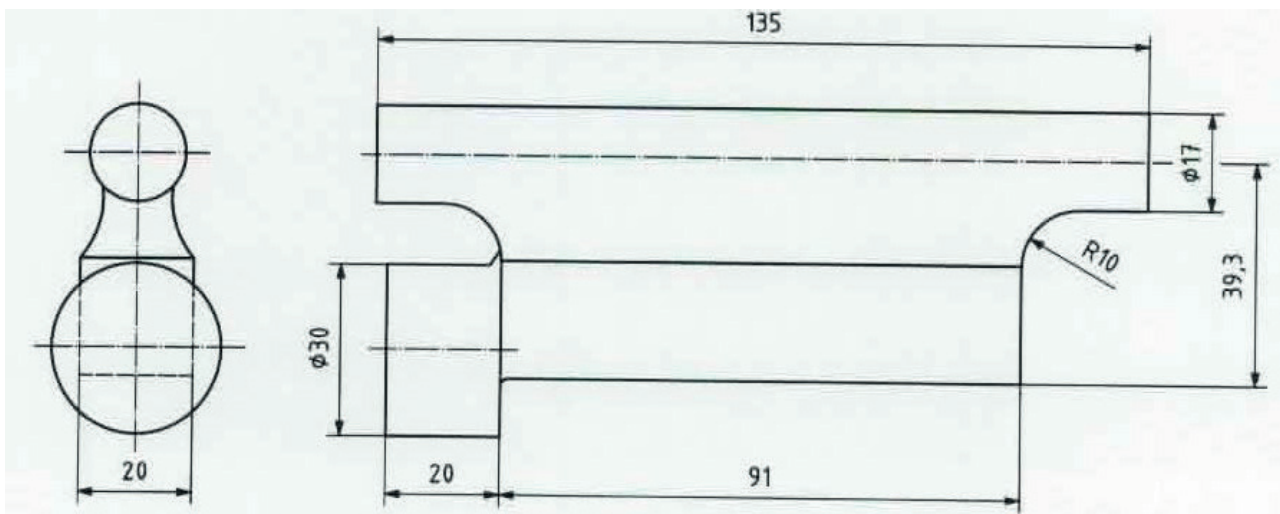

f)

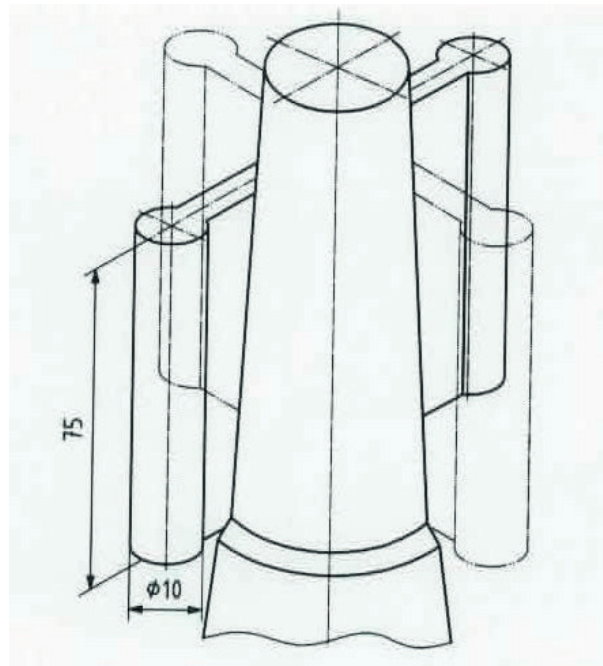

g)

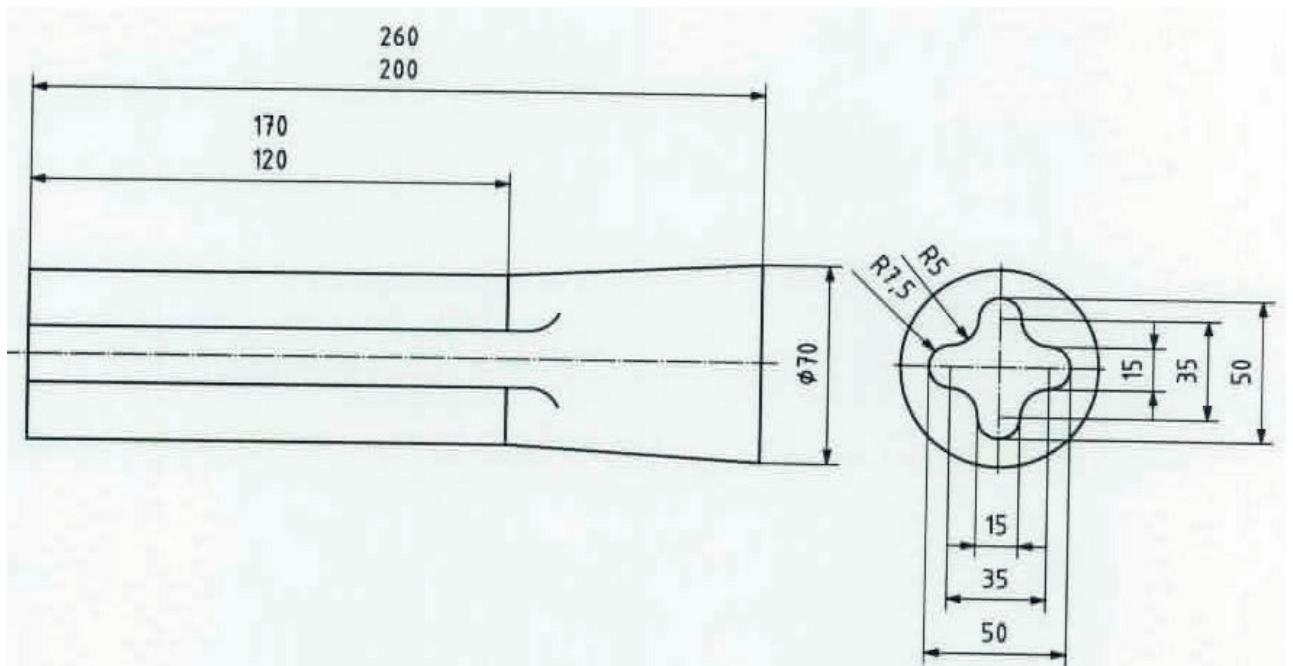

h)

Key

- t* taper
- a* alternative

Figure 1 — Test blocks

6 Retests

In addition to the requirements of ISO 4990, if any specimen shows defective machining or develops flaws, it may be discarded and another specimen substituted from the same primary heat.

7 Cleaning and dressing

All the castings shall be cleaned and dressed sufficiently to determine compliance with the requirements of [Clause 8](#). Additional dressing may be agreed at the time of the enquiry and order.

If the pattern is supplied by the purchaser, or is produced using a die supplied by the purchaser, the dimensions of the casting shall be as produced by the pattern or die.

8 Quality

8.1 Visual standards for acceptance shall be agreed between the purchaser and manufacturer. ISO 11971 may be used to specify visual surface standards. Other surface conditions shall meet the visual acceptance standards specified in the order. Unacceptable visual surface discontinuities shall be removed and their removal verified by visual examination.

8.2 When additional inspection is desired, [10.3](#), [10.4](#), [10.5](#), [10.6](#), or [10.7](#) may be specified.

9 Production welds

Production welding shall be in accordance with the requirements of ISO 11970.

10 Supplementary requirements

10.1 General

One or more of the following supplementary requirements may be applied when specified in the enquiry and order. Additional supplementary requirements may also be found in ISO 4990. Details of these supplementary requirements shall be agreed upon by the manufacturer and purchaser at the time of the enquiry and order. The specified tests shall be carried out before delivery of the castings.

10.2 Agreed manufacturing procedure

At the time of enquiry and order, the purchaser may require prior approval of the manufacturing process.

10.3 Magnetic particle inspection

Castings shall be inspected for surface and near-surface discontinuities by magnetic particle inspection. The inspection shall be in accordance with ISO 4986. The extent of inspection and the basis for acceptance shall be agreed upon between the manufacturer and the purchaser.

10.4 Radiographic inspection

Castings shall be inspected for internal defects by means of X-rays or gamma rays. The procedure shall be in accordance with ISO 4993. The extent of inspection and the basis for acceptance shall be agreed upon between the manufacturer and purchaser.

10.5 Liquid penetrant inspection

Castings shall be inspected for surface discontinuities by means of liquid penetrant inspection. The inspection shall be in accordance with ISO 4987. Areas to be inspected, methods and types of liquid penetrants to be used, developing procedure, and the basis for acceptance shall be agreed upon between the manufacturer and purchaser.

10.6 Ultrasonic inspection

Castings shall be inspected for internal defects by means of ultrasonic inspection. The procedure shall be in accordance with ISO 4992-1 or ISO 4992-2. The extent of inspection and the basis for acceptance shall be agreed upon between the manufacturer and purchaser.

10.7 Inspection of weld preparation

Surfaces prepared for welding shall be inspected, using the same methods and acceptance criteria as specified for the casting, to verify removal of discontinuities.

10.8 Prior agreement relating to major finishing welds

The requirements related to major finishing welds shall be in accordance with ISO 4990.

10.9 Impact test at low temperatures

The requirements related to the impact test at low temperatures shall be in accordance with ISO 4990.

10.10 Hardness test

10.10.1 Brinell

Brinell hardness tests at specified locations of the castings shall be carried out in accordance with ISO 6506-1, and shall be reported.

10.10.2 Rockwell

Rockwell hardness tests at specified locations of the castings shall be carried out in accordance with ISO 6508-1, and shall be reported.

10.10.3 Vickers

Vickers hardness tests at specified locations of the castings shall be carried out in accordance with ISO 6507-1, and shall be reported.

10.11 Specified ferrite range in austenitic and austenitic ferritic stainless steels

10.11.1 The chemical composition of the melt shall be controlled such that the ferrite content, as determined by the chemical composition procedure of ISO 13520, shall be in conformance with the specified ferrite content range.

10.11.2 The specified ferrite content shall be as agreed upon between the manufacturer and the purchaser. If both minimum and maximum ferrite contents are specified, the minimum specified range of ferrite content shall be 10 %. The minimum specified ferrite content shall not be lower than the percent necessary to achieve the minimum mechanical properties required for the alloy.

10.11.3 Should the purchaser wish to have the ferrite content determined by either the magnetic response or metallographic methods, the purchaser should impose these requirements at the time of the enquiry.

10.12 Unspecified elements

Chemical analysis and limits for elements not specified for the grade ordered shall be as agreed upon between the manufacturer and purchaser.

10.13 Test material removed from castings

In addition to the tests required by the material specification, test material shall be removed from the casting. The properties and location of the test material shall be agreed upon between the manufacturer and purchaser.

10.14 Tensile test blocks and specimen locations for castings

10.14.1 Test blocks may be cast integrally with the shell in which the castings are produced or in separate shells. Test blocks shall be heat treated together with the castings they represent.

10.14.2 The dimensions of the test block, the number and locations of the specimens, and the limits for the mechanical properties shall be agreed upon between the manufacturer and purchaser.

10.15 Weld maps (sketches)

The requirements related to weld maps shall be in accordance with ISO 4990.

10.16 Chemical analysis — Testing frequency

The frequency of chemical analysis shall be as agreed upon between the purchaser and manufacturer.

10.17 Tensile test — Testing frequency

The frequency of tensile tests shall be as agreed upon between the purchaser and manufacturer.

10.18 Inspection documents

Documents for specific inspection and testing shall be supplied in accordance with ISO 10474.

10.19 Marking

The castings shall be marked for identification, or traceability, or both. The content of the marking and the method of marking, including size, location, and style, shall be as agreed upon between the purchaser and the producer.

10.20 Decarburization

A casting or block shall be evaluated for the degree and depth of decarburization. The test method, location and preparation of samples, and the basis for acceptance shall be agreed upon between the purchaser and manufacturer.

10.21 Metallurgical cleanliness

10.21.1 The details of the method for inspection and the basis for acceptance shall be agreed upon between the purchaser and manufacturer.

10.21.2 It is realized that the foundry may be unable to perform the inspection for metallurgical cleanliness prior to shipment, or that the purchaser may wish to defer inspection until after additional work or machining has been performed on the casting. However, the foundry is responsible for the castings under the final inspection required in [10.21.1](#).

Bibliography

- [1] ISO 4991, *Steel castings for pressure purposes*
- [2] ISO 9477, *High strength cast steels for general engineering and structural purposes*
- [3] ISO 11971, *Steel and iron castings — Visual examination of surface quality*
- [4] ISO 11972, *Corrosion-resistant cast steels for general applications*
- [5] ISO 11973, *Heat-resistant cast steels and alloys for general applications*
- [6] ISO 12725, *Nickel and nickel alloy castings*
- [7] ISO 13521, *Austenitic manganese steel castings*
- [8] ISO 13583-2, *Centrifugally cast steel and alloy products — Part 2: Heat resistant materials*
- [9] ISO 14737, *Carbon and low alloy cast steels for general applications*

British Standards Institution (BSI)

BSI is the national body responsible for preparing British Standards and other standards-related publications, information and services.

BSI is incorporated by Royal Charter. British Standards and other standardization products are published by BSI Standards Limited.

About us

We bring together business, industry, government, consumers, innovators and others to shape their combined experience and expertise into standards-based solutions.

The knowledge embodied in our standards has been carefully assembled in a dependable format and refined through our open consultation process. Organizations of all sizes and across all sectors choose standards to help them achieve their goals.

Information on standards

We can provide you with the knowledge that your organization needs to succeed. Find out more about British Standards by visiting our website at bsigroup.com/standards or contacting our Customer Services team or Knowledge Centre.

Buying standards

You can buy and download PDF versions of BSI publications, including British and adopted European and international standards, through our website at bsigroup.com/shop, where hard copies can also be purchased.

If you need international and foreign standards from other Standards Development Organizations, hard copies can be ordered from our Customer Services team.

Subscriptions

Our range of subscription services are designed to make using standards easier for you. For further information on our subscription products go to bsigroup.com/subscriptions.

With **British Standards Online (BSOL)** you'll have instant access to over 55,000 British and adopted European and international standards from your desktop. It's available 24/7 and is refreshed daily so you'll always be up to date.

You can keep in touch with standards developments and receive substantial discounts on the purchase price of standards, both in single copy and subscription format, by becoming a **BSI Subscribing Member**.

PLUS is an updating service exclusive to BSI Subscribing Members. You will automatically receive the latest hard copy of your standards when they're revised or replaced.

To find out more about becoming a BSI Subscribing Member and the benefits of membership, please visit bsigroup.com/shop.

With a **Multi-User Network Licence (MUNL)** you are able to host standards publications on your intranet. Licences can cover as few or as many users as you wish. With updates supplied as soon as they're available, you can be sure your documentation is current. For further information, email bsmusales@bsigroup.com.

BSI Group Headquarters

389 Chiswick High Road London W4 4AL UK

Revisions

Our British Standards and other publications are updated by amendment or revision.

We continually improve the quality of our products and services to benefit your business. If you find an inaccuracy or ambiguity within a British Standard or other BSI publication please inform the Knowledge Centre.

Copyright

All the data, software and documentation set out in all British Standards and other BSI publications are the property of and copyrighted by BSI, or some person or entity that owns copyright in the information used (such as the international standardization bodies) and has formally licensed such information to BSI for commercial publication and use. Except as permitted under the Copyright, Designs and Patents Act 1988 no extract may be reproduced, stored in a retrieval system or transmitted in any form or by any means – electronic, photocopying, recording or otherwise – without prior written permission from BSI. Details and advice can be obtained from the Copyright & Licensing Department.

Useful Contacts:

Customer Services

Tel: +44 845 086 9001

Email (orders): orders@bsigroup.com

Email (enquiries): cservices@bsigroup.com

Subscriptions

Tel: +44 845 086 9001

Email: subscriptions@bsigroup.com

Knowledge Centre

Tel: +44 20 8996 7004

Email: knowledgecentre@bsigroup.com

Copyright & Licensing

Tel: +44 20 8996 7070

Email: copyright@bsigroup.com



...making excellence a habit.™