

BS ISO 16462:2014



BSI Standards Publication

Cubic boron nitride inserts, tipped or solid — Dimensions, types

bsi.

...making excellence a habit.™

National foreword

This British Standard is the UK implementation of ISO 16462:2014. It supersedes BS ISO 16462:2004 which is withdrawn.

The UK participation in its preparation was entrusted to Technical Committee MTE/18, Tools tips and inserts for cutting applications.

A list of organizations represented on this committee can be obtained on request to its secretary.

This publication does not purport to include all the necessary provisions of a contract. Users are responsible for its correct application.

© The British Standards Institution 2014.
Published by BSI Standards Limited 2014

ISBN 978 0 580 83606 0
ICS 25.100.01

Compliance with a British Standard cannot confer immunity from legal obligations.

This British Standard was published under the authority of the Standards Policy and Strategy Committee on 31 May 2014.

Amendments/corrigenda issued since publication

Date	Text affected
------	---------------

Cubic boron nitride inserts, tipped or solid — Dimensions, types

*Plaquettes en nitrure de bore cubique, brasées ou monobloc —
Dimensions, types*





COPYRIGHT PROTECTED DOCUMENT

© ISO 2014

All rights reserved. Unless otherwise specified, no part of this publication may be reproduced or utilized otherwise in any form or by any means, electronic or mechanical, including photocopying, or posting on the internet or an intranet, without prior written permission. Permission can be requested from either ISO at the address below or ISO's member body in the country of the requester.

ISO copyright office
Case postale 56 • CH-1211 Geneva 20
Tel. + 41 22 749 01 11
Fax + 41 22 749 09 47
E-mail copyright@iso.org
Web www.iso.org

Published in Switzerland

Contents

Page

Foreword	iv
1 Scope	1
2 Normative references	1
3 Insert shapes and design	1
3.1 Insert shapes.....	1
3.2 Normal clearance α_n	1
3.3 Cutting edge corner.....	1
3.4 Tolerance class.....	1
3.5 Design of cutting edges.....	2
3.6 Insert type.....	2
4 Designation	2
4.1 General.....	2
4.2 Designation of inserts for turning.....	2
4.3 Designation of a tipped insert for milling.....	2
5 Dimensions	3
5.1 Insert shape T with fixing hole (inserts for turning).....	3
5.2 Insert shape S with fixing hole (inserts for turning).....	4
5.3 Insert shape C with fixing hole (inserts for turning).....	5
5.4 Insert shape D with fixing hole (inserts for turning).....	6
5.5 Insert shape V with fixing hole (inserts for turning).....	7
5.6 Insert shape S with fixing hole (inserts for milling).....	8
5.7 Insert shape C with fixing hole (inserts for milling).....	9
5.8 Insert shapes C, R, S, and T without fixing hole (inserts for turning).....	9
5.9 Insert shapes S and T without fixing hole (inserts for milling).....	11
5.10 Insert shapes S and T without fixing hole (inserts for milling).....	12
5.11 Insert shape W with fixing hole (inserts for turning).....	13
5.12 Insert shape W without fixing hole (inserts for turning).....	14
6 Cutting edge length, l_1, of tipped inserts	15
6.1 General.....	15
6.2 Inserts with radius.....	15
6.3 Inserts with wiper edge.....	15
7 Base material, cutting material	16
8 Measurements	16
9 Marking	16
Annex A (informative) Relationship between designations in ISO 16462 and ISO/TS 13399-2	17

Foreword

ISO (the International Organization for Standardization) is a worldwide federation of national standards bodies (ISO member bodies). The work of preparing International Standards is normally carried out through ISO technical committees. Each member body interested in a subject for which a technical committee has been established has the right to be represented on that committee. International organizations, governmental and non-governmental, in liaison with ISO, also take part in the work. ISO collaborates closely with the International Electrotechnical Commission (IEC) on all matters of electrotechnical standardization.

The procedures used to develop this document and those intended for its further maintenance are described in the ISO/IEC Directives, Part 1. In particular the different approval criteria needed for the different types of ISO documents should be noted. This document was drafted in accordance with the editorial rules of the ISO/IEC Directives, Part 2 (see www.iso.org/directives).

Attention is drawn to the possibility that some of the elements of this document may be the subject of patent rights. ISO shall not be held responsible for identifying any or all such patent rights. Details of any patent rights identified during the development of the document will be in the Introduction and/or on the ISO list of patent declarations received (see www.iso.org/patents).

Any trade name used in this document is information given for the convenience of users and does not constitute an endorsement.

For an explanation on the meaning of ISO specific terms and expressions related to conformity assessment, as well as information about ISO's adherence to the WTO principles in the Technical Barriers to Trade (TBT) see the following URL: Foreword - Supplementary information

The committee responsible for this document is ISO/TC 29, *Small Tools*, Subcommittee SC 9, *Tools with cutting edges made of hard cutting materials*.

This second edition cancels and replaces the first edition (ISO 16462:2004), of which it constitutes a minor revision.

Cubic boron nitride inserts, tipped or solid — Dimensions, types

1 Scope

This International Standard applies to inserts with insert shapes in accordance with ISO 883, ISO 3364, ISO 3365, and ISO 6987, tipped with cubic boron nitride (BL, BH, BC) or made of solid cubic boron nitride (BL, BH, BC).

2 Normative references

The following documents, in whole or in part, are normatively referenced in this document and are indispensable for its application. For dated references, only the edition cited applies. For undated references, the latest edition of the referenced document (including any amendments) applies.

ISO 513, *Classification and application of hard cutting materials for metal removal with defined cutting edges — Designation of the main groups and groups of application*

ISO 883, *Indexable hardmetal (carbide) inserts with rounded corners, without fixing hole — Dimensions*

ISO 1832, *Indexable inserts for cutting tools — Designation*

ISO 3364, *Indexable hardmetal (carbide) inserts with rounded corners, with cylindrical fixing hole — Dimensions*

ISO 3365, *Indexable hardmetal (carbide) inserts with wiper edges, without fixing hole — Dimensions*

ISO 6987, *Indexable hard material inserts with rounded corners, with partly cylindrical fixing hole — Dimensions*

3 Insert shapes and design

3.1 Insert shapes

Triangular (T), square (S), rhombic 80° (C), 55° (D) and 35° (V), round (R), and trigon (W).

3.2 Normal clearance α_n

Normal clearance 0° (N), 5° (B), 7° (C), and 11° (P).

3.3 Cutting edge corner

Inserts for turning with corner radius r_ϵ 0,2 mm, 0,4 mm, 0,8 mm, 1,2 mm, and 1,6 mm.

Inserts for milling with wiper edge.

NOTE The design of non-tipped corners is optional.

3.4 Tolerance class

Tolerance class in accordance with ISO 1832 shall be applied. In [Tables 1](#) to [12](#), this position is shown with a dot (•).

3.5 Design of cutting edges

Any design shall be indicated in the designation (see ISO 1832).

3.6 Insert type

The styles of tipped or solid cutting edges in accordance with ISO 1832 shall be applied.

4 Designation

4.1 General

The designation of inserts tipped or solid with cubic boron nitride (BL, BH, BC) is based on ISO 1832. The letter symbol for the cutting edge condition and the letter symbol for the insert type shall be indicated in the designation in each case.

Designations contained in 4.2 and 4.3 are examples of the use of designations in accordance with ISO 1832.

4.2 Designation of inserts for turning

4.2.1 Solid insert (S)

Designation of a rhombic insert with included angle $\varepsilon_r = 80^\circ$ (C), normal clearance $\alpha_n = 0^\circ$ (N), with tolerance class M, without chip breakers and without fixing hole (N), with side length $l = 9,67$ mm (09), thickness $s = 3,18$ mm (03), corner radius $r_\varepsilon = 0,8$ mm (08), with chamfered and rounded cutting edges (S), insert type solid (S), cutting material in accordance with ISO 513 (e.g. BL05):

Insert CNMN 090308S — S — BL05 —

NOTE BL05 is optional in accordance with ISO 1832, designation symbol 13.

4.2.2 Insert, tipped — full thickness — one corner (T)

Designation of a rhombic insert with included angle $\varepsilon_r = 55^\circ$ (D), normal clearance $\alpha_n = 0^\circ$ (N), with tolerance class M, without chip breakers and with cylindrical fixing hole (A), with side length $l = 15,5$ mm (15), thickness $s = 4,76$ mm (04), corner radius $r_\varepsilon = 0,8$ mm (08), with chamfered and rounded cutting edges (S), tipped — full thickness — one corner (T), long (L), cutting material in accordance with ISO 513 (e.g. BL05):

Insert DNMA 150408S — TL — BL05 —

NOTE BL05 is optional in accordance with ISO 1832, designation symbol 13.

4.3 Designation of a tipped insert for milling

Designation of a square insert (S) with normal clearance $\alpha_n = 7^\circ$ (C), with tolerance class G, without chip breakers and with fixing hole (W), with side length $l = 12,7$ mm (12), thickness $s = 4,76$ mm (04), cutting edge angle $\kappa_r = 75^\circ$ (E), normal clearance at wiper edge $\alpha = 15^\circ$ (D), right-hand type (R), tipped — one side — one corner (A), long (L), cutting material in accordance with ISO 513 (e.g. BL05):

Insert SCGW 1204EDR — AL — BL05 —

NOTE BL05 is optional in accordance with ISO 1832, designation symbol 13.

5 Dimensions

5.1 Insert shape T with fixing hole (inserts for turning)

See [Figure 1](#) and [Table 1](#).

NOTE For the dimensions of l_1 , see [Table 13](#).

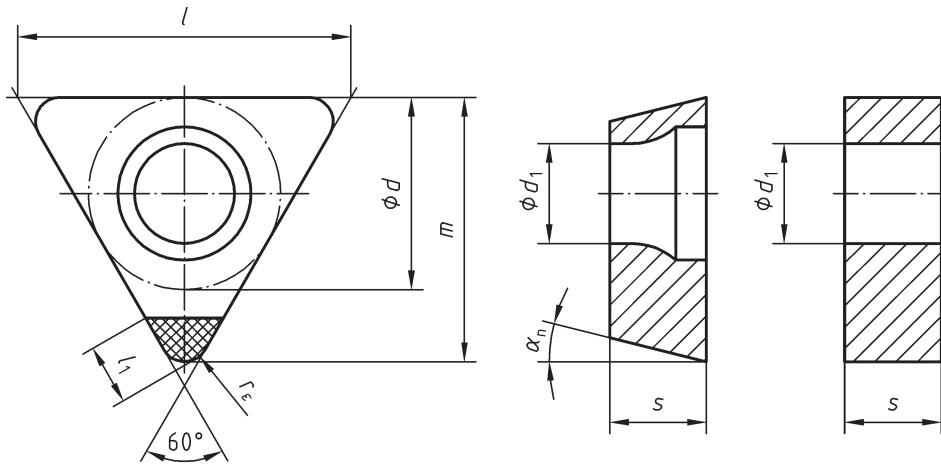

Figure 1

Table 1

Designation	d	d_1	l \approx	m	s	α_n	r_ϵ
TC•W 09 02 02S	5,56	2,5	9,63	8,137	2,38	7°	0,2
TC•W 09 02 04S	5,56	2,5	9,63	7,943	2,38	7°	0,4
TC•W 09 02 08S	5,56	2,5	9,63	7,541	2,38	7°	0,8
TC•W 11 02 02S	6,35	2,8	11	9,322	2,38	7°	0,2
TC•W 11 02 04S	6,35	2,8	11	9,128	2,38	7°	0,4
TC•W 11 02 08S	6,35	2,8	11	8,731	2,38	7°	0,8
TC•W 16 T3 02S	9,525	4,4	16,5	14,084	3,97	7°	0,2
TC•W 16 T3 04S	9,525	4,4	16,5	13,891	3,97	7°	0,4
TC•W 16 T3 08S	9,525	4,4	16,5	13,494	3,97	7°	0,8
TC•W 16 T3 12S	9,525	4,4	16,5	13,097	3,97	7°	1,2
TC•W 16 T3 16S	9,525	4,4	16,5	12,700	3,97	7°	1,6
TN•A 11 03 02S	6,35	2,26	11	9,322	3,18	0°	0,2
TN•A 11 03 04S	6,35	2,26	11	9,128	3,18	0°	0,4
TN•A 11 03 08S	6,35	2,26	11	8,731	3,18	0°	0,8
TN•A 16 04 04S	9,525	3,81	16,5	13,891	4,76	0°	0,4
TN•A 16 04 08S	9,525	3,81	16,5	13,494	4,76	0°	0,8
TN•A 16 04 12S	9,525	3,81	16,5	13,097	4,76	0°	1,2
TN•A 16 04 16S	9,525	3,81	16,5	12,700	4,76	0°	1,6
TP•W 08 02 02S	4,763	2,3	8,2	6,945	2,38	11°	0,2
TP•W 08 02 04S	4,763	2,3	8,2	6,747	2,38	11°	0,4
TP•W 08 02 08S	4,763	2,3	8,2	6,350	2,38	11°	0,8
TP•W 09 02 02S	5,56	2,5	9,63	8,137	2,38	11°	0,2

Table 1 — (continued)

Designation	d	d_1	l \approx	m	s	α_n	r_ϵ
TP•W 09 02 04S	5,56	2,5	9,63	7,943	2,38	11°	0,4
TP•W 09 02 08S	5,56	2,5	9,63	7,541	2,38	11°	0,8
TP•W 11 02 02S	6,35	2,8	11	8,731	2,38	11°	0,2
TP•W 11 02 04S	6,35	2,8	11	8,137	2,38	11°	0,4
TP•W 11 02 08S	6,35	2,8	11	7,943	2,38	11°	0,8
TP•W 11 03 02S	6,35	3,3	11,0	9,327	3,18	11°	0,2
TP•W 11 03 04S	6,35	3,3	11,0	9,128	3,18	11°	0,4
TP•W 11 03 08S	6,35	3,3	11,0	8,731	3,18	11°	0,8
TP•W 16 03 04S	9,525	4,4	16,5	13,891	3,18	11°	0,4
TP•W 16 03 08S	9,525	4,4	16,5	13,494	3,18	11°	0,8
TP•W 16 T3 04S	9,525	4,4	16,5	13,891	3,97	11°	0,4
TP•W 16 T3 08S	9,525	4,4	16,5	13,494	3,97	11°	0,8
TP•W 16 T3 12S	9,525	4,4	16,5	13,097	3,97	11°	1,2
TP•W 16 T3 16S	9,525	4,4	16,5	12,700	3,97	11°	1,6
TP•W 16 04 04S	9,525	4,4	16,5	13,891	4,76	11°	0,4
TP•W 16 04 08S	9,525	4,4	16,5	13,494	4,76	11°	0,8

5.2 Insert shape S with fixing hole (inserts for turning)

See [Figure 2](#) and [Table 2](#).

NOTE For the dimensions of l_1 , see [Table 13](#).

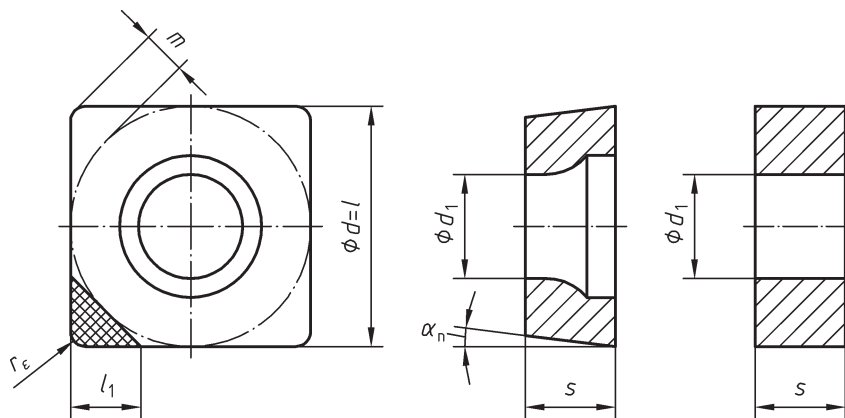

Figure 2

Table 2

Designation	d	d_1	l \approx	m	s	α_n	r_ϵ
SC•W 09 T3 02S	9,525	4,4	9,525	1,889	3,97	7°	0,2
SC•W 09 T3 04S	9,525	4,4	9,525	1,808	3,97	7°	0,4
SC•W 09 T3 08S	9,525	4,4	9,525	1,644	3,97	7°	0,8
SC•W 09 T3 12S	9,525	4,4	9,525	1,479	3,97	7°	1,2
SC•W 12 04 04S	12,7	5,5	12,7	2,466	4,76	7°	0,4

Table 2 — (continued)

Designation	d	d_1	l \approx	m	s	α_n	r_ϵ
SC•W 12 04 08S	12,7	5,5	12,7	2,301	4,76	7°	0,8
SC•W 12 04 12S	12,7	5,5	12,7	2,137	4,76	7°	1,2
SN•A 09 03 04S	9,525	3,81	9,525	1,808	3,18	0°	0,4
SN•A 09 03 08S	9,525	3,81	9,525	1,644	3,18	0°	0,8
SN•A 09 03 12S	9,525	3,81	9,525	1,479	3,18	0°	1,2
SN•A 12 04 04S	12,7	5,16	12,7	2,466	4,76	0°	0,4
SN•A 12 04 08S	12,7	5,16	12,7	2,301	4,76	0°	0,8
SN•A 12 04 12S	12,7	5,16	12,7	2,137	4,76	0°	1,2
SN•A 12 04 16S	12,7	5,16	12,7	1,972	4,76	0°	1,6

5.3 Insert shape C with fixing hole (inserts for turning)

See [Figure 3](#) and [Table 3](#).

NOTE For the dimensions of l_1 , see [Table 13](#).

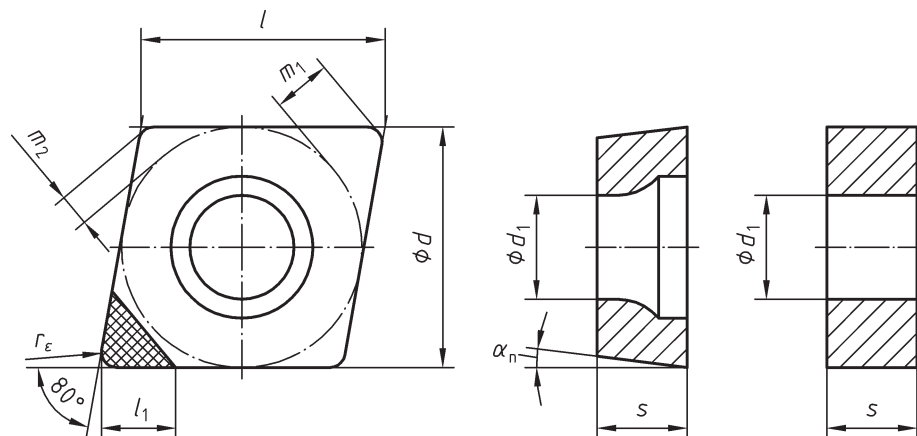

Figure 3

Table 3

Designation	d	d_1	l \approx	m_1	m_2	s	α_n	r_ϵ
CC•W 06 02 02S	6,35	2,8	6,45	1,652	0,908	2,38	7°	0,2
CC•W 06 02 04S	6,35	2,8	6,45	1,544	0,848	2,38	7°	0,4
CC•W 06 02 08S	6,35	2,8	6,45	1,323	0,727	2,38	7°	0,8
CC•W 09 T3 02S	9,525	4,4	9,67	2,535	1,392	3,97	7°	0,2
CC•W 09 T3 04S	9,525	4,4	9,67	2,426	1,333	3,97	7°	0,4
CC•W 09 T3 08S	9,525	4,4	9,67	2,206	1,212	3,97	7°	0,8
CC•W 09 T3 12S	9,525	4,4	9,67	1,985	1,091	3,97	7°	1,2
CC•W 12 04 04S	12,7	5,5	12,9	3,308	1,818	4,76	7°	0,4
CC•W 12 04 08S	12,7	5,5	12,9	3,088	1,697	4,76	7°	0,8
CC•W 12 04 12S	12,7	5,5	12,9	2,867	1,576	4,76	7°	1,2
CC•W 12 04 16S	12,7	5,5	12,9	2,646	1,454	4,76	7°	1,6

Table 3 — (continued)

Designation	d	d_1	l \approx	m_1	m_2	s	α_n	r_ϵ
CN•A 09 03 04S	9,525	3,81	9,67	2,426	1,333	3,18	0°	0,4
CN•A 09 03 08S	9,525	3,81	9,67	2,206	1,212	3,18	0°	0,8
CN•A 12 04 04S	12,7	5,16	12,9	3,308	1,818	4,76	0°	0,4
CN•A 12 04 08S	12,7	5,16	12,9	3,088	1,697	4,76	0°	0,8
CN•A 12 04 12S	12,7	5,16	12,9	2,867	1,576	4,76	0°	1,2
CN•A 12 04 16S	12,7	5,16	12,9	2,646	1,454	4,76	0°	1,6
CP•W 06 02 02S	6,35	2,8	6,45	1,652	0,908	2,38	11°	0,2
CP•W 06 02 04S	6,35	2,8	6,45	1,544	0,848	2,38	11°	0,4
CP•W 06 02 08S	6,35	2,8	6,45	1,323	0,727	2,38	11°	0,8
CP•W 09 03 02S	9,525	4,4	9,67	2,534	1,392	3,18	11°	0,2
CP•W 09 03 04S	9,525	4,4	9,67	2,426	1,333	3,18	11°	0,4
CP•W 09 03 08S	9,525	4,4	9,67	2,206	1,212	3,18	11°	0,8
CP•W 09 T3 02S	9,525	4,4	9,67	2,534	1,392	3,97	11°	0,2
CP•W 09 T3 04S	9,525	4,4	9,67	2,426	1,333	3,97	11°	0,4
CP•W 09 T3 08S	9,525	4,4	9,67	2,206	1,212	3,97	11°	0,8
CP•W 09 T3 12S	9,525	4,4	9,67	1,985	1,091	3,97	11°	1,2

5.4 Insert shape D with fixing hole (inserts for turning)

See [Figure 4](#) and [Table 4](#).

NOTE For the dimensions of l_1 , see [Table 13](#).

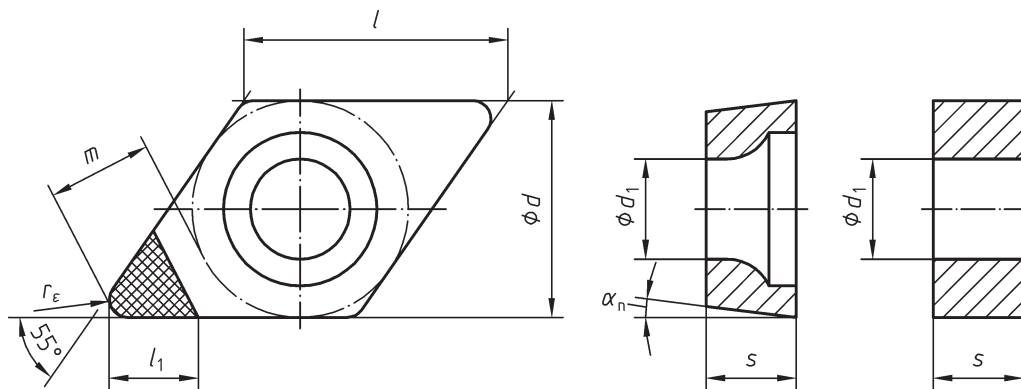

Figure 4

Table 4

Designation	d	d_1	l \approx	m	s	α_n	r_ϵ
DC•W 07 02 02S	6,35	2,8	7,75	3,464	2,38	7°	0,2
DC•W 07 02 04S	6,35	2,8	7,75	3,238	2,38	7°	0,4
DC•W 07 02 08S	6,35	2,8	7,75	2,776	2,38	7°	0,8
DC•W 11 T3 02S	9,525	4,4	11,6	5,315	3,97	7°	0,2
DC•W 11 T3 04S	9,525	4,4	11,6	5,089	3,97	7°	0,4
DC•W 11 T3 08S	9,525	4,4	11,6	4,626	3,97	7°	0,8
DC•W 11 T3 12S	9,525	4,4	11,6	4,164	3,97	7°	1,2
DN•A 11 04 04S	9,525	3,81	11,6	5,089	4,76	0°	0,4
DN•A 11 04 08S	9,525	3,81	11,6	4,626	4,76	0°	0,8
DN•A 15 04 04S	12,7	5,16	15,5	6,939	4,76	0°	0,4
DN•A 15 04 08S	12,7	5,16	15,5	6,477	4,76	0°	0,8
DN•A 15 04 12S	12,7	5,16	15,5	6,014	4,76	0°	1,2
DN•A 15 06 04S	12,7	5,16	15,5	6,939	6,35	0°	0,4
DN•A 15 06 08S	12,7	5,16	15,5	6,477	6,35	0°	0,8
DN•A 15 06 12S	12,7	5,16	15,5	6,014	6,35	0°	1,2
DN•A 15 06 16S	12,7	5,16	15,5	5,551	6,35	0°	1,6

5.5 Insert shape V with fixing hole (inserts for turning)

See [Figure 5](#) and [Table 5](#).

NOTE For the dimensions of l_1 , see [Table 13](#).

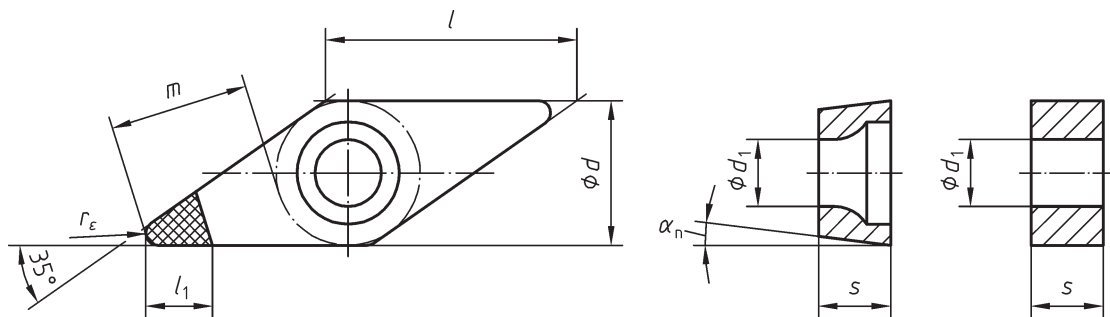

Figure 5

Table 5

Designation	d	d_1	l \approx	m	s	α_n	r_ϵ
VC•W 11 03 02S	6,35	2,8	11,1	6,911	3,18	7°	0,2
VC•W 11 03 04S	6,35	2,8	11,1	6,460	3,18	7°	0,4
VC•W 11 03 08S	6,35	2,8	11,1	5,537	3,18	7°	0,8
VC•W 16 04 02S	9,525	4,4	16,6	10,603	4,76	7°	0,2
VC•W 16 04 04S	9,525	4,4	16,6	10,154	4,76	7°	0,4
VC•W 16 04 08S	9,525	4,4	16,6	9,231	4,76	7°	0,8
VC•W 16 04 12S	9,525	4,4	16,6	8,306	4,76	7°	1,2

Table 5 — (continued)

Designation	d	d_1	l \approx	m	s	α_n	r_ϵ
VB•W 16 04 02S	9,525	4,4	16,6	10,602	4,76	5°	0,2
VB•W 16 04 04S	9,525	4,4	16,6	10,152	4,76	5°	0,4
VB•W 16 04 08S	9,525	4,4	16,6	9,229	4,76	5°	0,8
VB•W 16 04 12S	9,525	4,4	16,6	8,306	4,76	5°	1,2
VN•A 16 04 04S	9,525	3,81	16,6	10,152	4,76	0°	0,4
VN•A 16 04 08S	9,525	3,81	16,6	9,229	4,76	0°	0,8
VN•A 16 04 12S	9,525	3,81	16,6	8,306	4,76	0°	1,2

5.6 Insert shape S with fixing hole (inserts for milling)

See [Figure 6](#) and [Table 6](#).

NOTE For the dimensions of l_1 , see [Table 13](#).

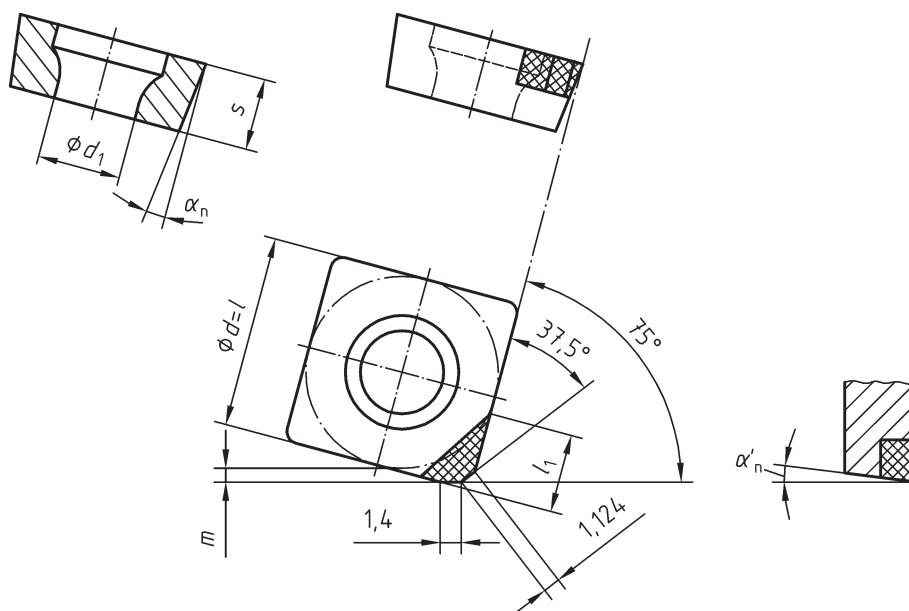

NOTE Right-hand type is shown in the figure (R).

Figure 6

Table 6

Designation	d	d_1	l \approx	m	s	α_n	α'_n
SC•W 09 T3 ECR	9,525	4,4	9,525	0,543	3,97	7°	7°
SC•W 12 04 ECR	12,7	5,5	12,7	0,900	4,76	7°	7°
SP•W 09 T3 EDR	9,525	4,4	9,525	0,543	3,97	11°	15°
SP•W 12 04 EDR	12,7	5,5	12,7	0,900	4,76	11°	15°

5.7 Insert shape C with fixing hole (inserts for milling)

See [Figure 7](#) and [Table 7](#).

NOTE For the dimensions of l_1 , see [Table 13](#).

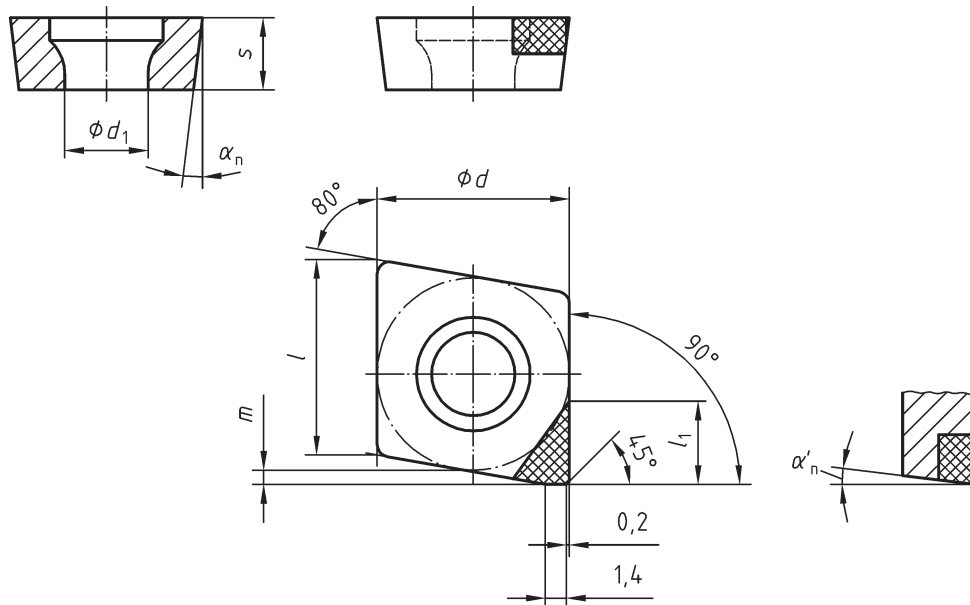

NOTE Right-hand type is shown in the figure (R).

Figure 7

Table 7

Designation	d	d_1	l \approx	m	s	α_n	α'_n
CC•W 09 T3 PCR	9,525	4,4	9,67	0,631	3,97	7°	7°
CC•W 12 04 PCR	12,7	5,5	12,9	0,936	4,76	7°	7°
CP•W 09 T3 PDR	9,525	4,4	9,67	0,631	3,97	11°	15°
CP•W 12 04 PDR	12,7	5,5	12,9	0,936	4,76	11°	15°

5.8 Insert shapes C, R, S, and T without fixing hole (inserts for turning)

See [Figure 8](#) and [Table 8](#).

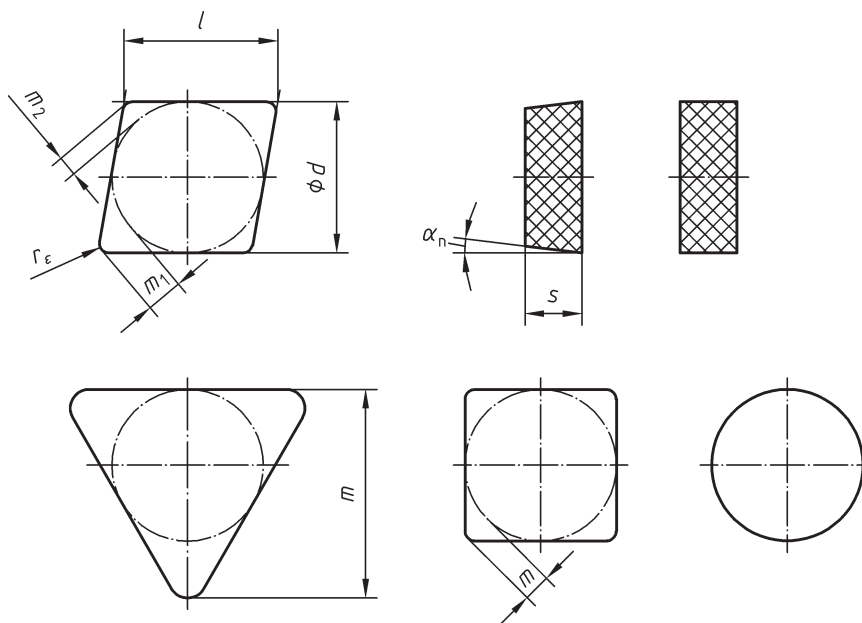

Figure 8

Table 8

Designation	d	l \approx	m	m_1	m_2	s	α_n	r_E
CN•N 09 03 04S	9,525	9,67	—	2,426	1,333	3,18	0°	0,4
CN•N 09 03 08S	9,525	9,67	—	2,206	1,212	3,18	0°	0,8
CN•N 09 03 12S	9,525	9,67	—	1,985	1,091	3,18	0°	1,2
CN•N 09 03 16S	9,525	9,67	—	1,764	0,970	3,18	0°	1,6
CN•N 12 04 04S	12,7	12,9	—	3,308	1,818	4,76	0°	0,4
CN•N 12 04 08S	12,7	12,9	—	3,088	1,697	4,76	0°	0,8
CN•N 12 04 12S	12,7	12,9	—	2,867	1,576	4,76	0°	1,2
CN•N 12 04 16S	12,7	12,9	—	2,646	1,454	4,76	0°	1,6
RC•N 09 03 00S	9,525	—	—	—	—	3,18	7°	—
RC•N 12 04 00S	12,7	—	—	—	—	4,76	7°	—
RN•N 09 03 00S	9,525	—	—	—	—	3,18	0°	—
RN•N 12 03 00S	12,7	—	—	—	—	3,18	0°	—
RN•N 12 04 00S	12,7	—	—	—	—	4,76	0°	—
SN•N 09 03 04S	9,525	9,525	1,808	—	—	3,18	0°	0,4
SN•N 09 03 08S	9,525	9,525	1,644	—	—	3,18	0°	0,8
SN•N 09 03 12S	9,525	9,525	1,479	—	—	3,18	0°	1,2
SN•N 09 03 16S	9,525	9,525	1,315	—	—	3,18	0°	1,6
SN•N 12 03 04S	12,7	12,7	2,466	—	—	3,18	0°	0,4
SN•N 12 03 08S	12,7	12,7	2,301	—	—	3,18	0°	0,8
SN•N 12 03 12S	12,7	12,7	2,137	—	—	3,18	0°	1,2
SN•N 12 03 16S	12,7	12,7	1,972	—	—	3,18	0°	1,6
SN•N 12 04 04S	12,7	12,7	2,466	—	—	4,76	0°	0,4
SN•N 12 04 08S	12,7	12,7	2,301	—	—	4,76	0°	0,8
SN•N 12 04 12S	12,7	12,7	2,137	—	—	4,76	0°	1,2

Table 8 — (continued)

Designation	d	l \approx	m	m_1	m_2	s	α_n	r_ϵ
SN•N 12 04 16S	12,7	12,7	1,972	—	—	4,76	0°	0,4
SP•N 09 03 04S	9,525	9,5	1,808	—	—	3,18	1°	1,6
SP•N 09 03 08S	9,525	9,5	1,644	—	—	3,18	11°	0,8
SP•N 09 03 12S	9,525	9,5	1,479	—	—	3,18	11°	1,2
SP•N 12 03 08S	12,7	12,7	2,301	—	—	3,18	11°	0,8
SP•N 12 03 12S	12,7	12,7	2,137	—	—	3,18	11°	1,2
SP•N 12 04 08S	12,7	12,7	2,301	—	—	4,76	11°	0,8
SP•N 12 04 12S	12,7	12,7	2,137	—	—	4,76	11°	1,2
SP•N 12 04 16S	12,7	12,7	1,973	—	—	4,76	11°	1,6
TB•N 06 01 02S	3,969	6,87	5,755	—	—	1,59	5°	0,2
TB•N 06 01 04S	3,969	6,87	5,557	—	—	1,59	5°	0,4
TB•N 06 01 08S	3,969	6,87	5,160	—	—	1,59	5°	0,8
TN•N 11 03 02S	6,35	11	9,322	—	—	3,18	0°	0,2
TN•N 11 03 04S	6,35	11	9,128	—	—	3,18	0°	0,4
TN•N 11 03 08S	6,35	11	8,731	—	—	3,18	0°	0,8
TN•N 11 03 12S	6,35	11	8,334	—	—	3,18	0°	1,2
TN•N 11 03 16S	6,35	11	7,937	—	—	3,18	0°	1,6
TN•N 16 04 04S	9,525	16,5	13,891	—	—	4,76	0°	0,4
TN•N 16 04 08S	9,525	16,5	13,494	—	—	4,76	0°	0,8
TN•N 16 04 12S	9,525	16,5	13,097	—	—	4,76	0°	1,2
TN•N 16 04 16S	9,525	16,5	12,700	—	—	4,76	0°	1,6
TP•N 11 03 04S	6,35	11	9,128	—	—	3,18	11°	0,4
TP•N 11 03 08S	6,35	11	8,731	—	—	3,18	11°	0,8
TP•N 11 03 12S	6,35	11	8,334	—	—	3,18	11°	1,2
TP•N 16 03 04S	9,525	16,5	13,891	—	—	3,18	11°	0,4
TP•N 16 03 08S	9,525	16,5	13,494	—	—	3,18	11°	0,8
TP•N 16 04 02S	9,525	16,5	14,089	—	—	4,76	11°	0,2
TP•N 16 04 04S	9,525	16,5	13,891	—	—	4,76	11°	0,4
TP•N 16 04 08S	9,525	16,5	13,494	—	—	4,76	11°	0,8
TP•N 16 04 12S	9,525	16,5	13,097	—	—	4,76	11°	1,2
TP•N 16 04 16S	9,525	16,5	12,700	—	—	4,76	11°	1,6

5.9 Insert shapes S and T without fixing hole (inserts for milling)

See [Figure 9](#) and [Table 9](#).

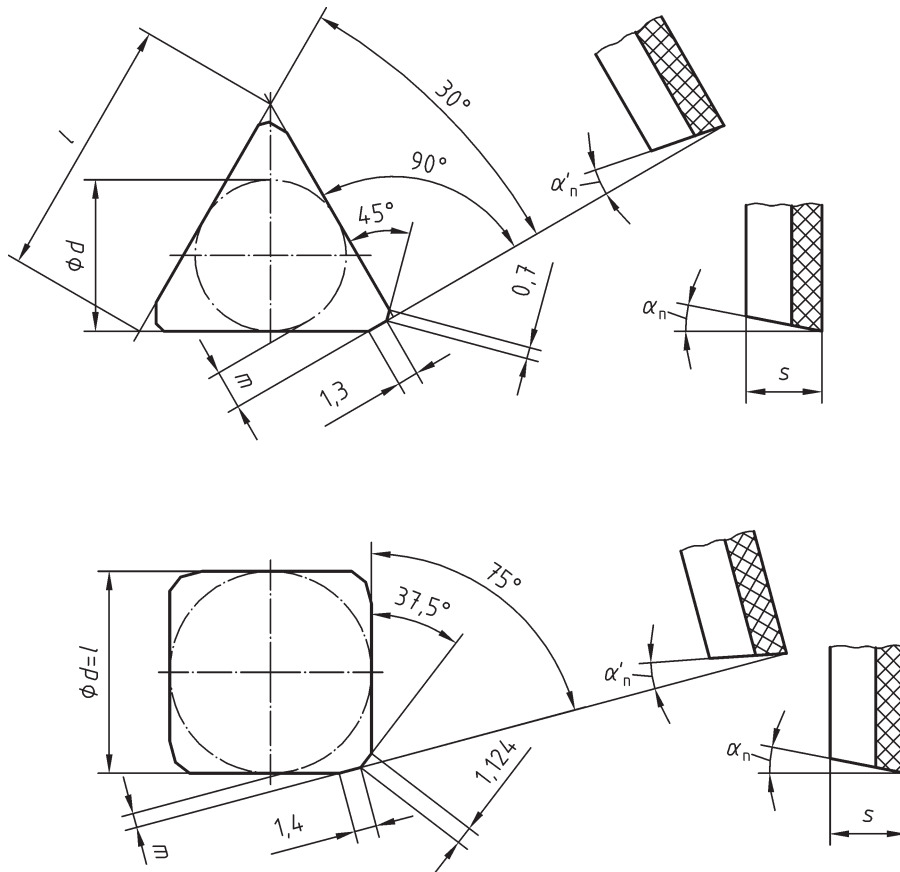

Figure 9

Table 9

Designation	d	l \approx	m	s	α_n	α'_n
SN•N 09 03 ENR	9,525	9,525	0,543	3,18	0°	0°
SN•N 12 04 ENR	12,7	12,7	0,900	4,76	0°	0°
SP•N 09 03 EPR	9,525	9,525	0,543	3,18	11°	11°
SP•N 12 04 EPR	12,7	12,7	0,900	4,76	11°	11°
TN•N 11 03 PNR	6,35	11	1,288	3,18	0°	0°
TC•N 16 04 PCR	9,525	16,5	2,450	4,76	7°	7°
TP•N 16 04 PPR	9,525	16,5	2,450	4,76	11°	11°

5.10 Insert shapes S and T without fixing hole (inserts for milling)

See [Figure 10](#) and [Table 10](#).

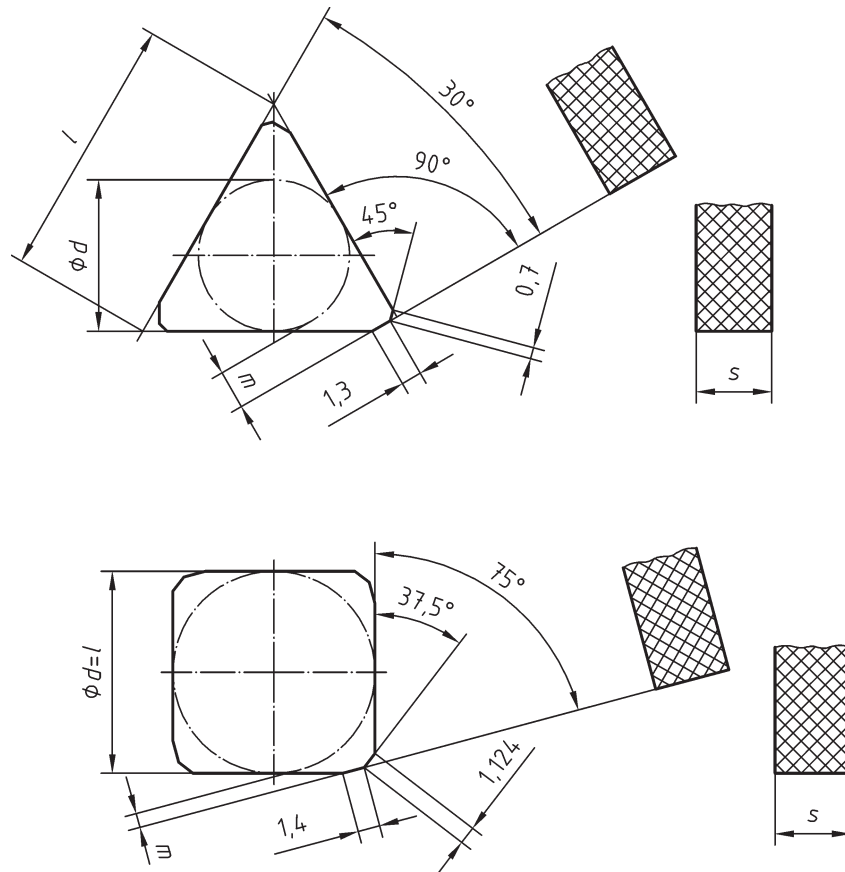

Figure 10

Table 10

Designation	d	l \approx	m	s	α_n
SN•N 09 03 EN	9,525	9,525	0,543	3,18	0°
SN•N 12 04 EN	12,7	12,7	0,900	4,76	0°
TN•N 11 03 PN	6,35	11	1,288	3,18	0°
TN•N 16 04 PN	9,525	16,5	2,450	4,76	0°

5.11 Insert shape W with fixing hole (inserts for turning)

See [Figure 11](#) and [Table 11](#).

NOTE For the dimensions of l_1 , see [Table 13](#).

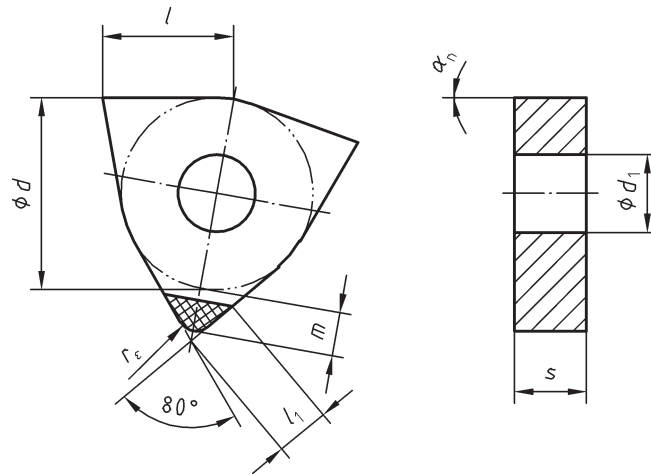

Figure 11

Table 11

Designation	d	d_1	l \approx	m	s	α_n	r_{ϵ}
WN•A 06 04 04	9,525	3,81	6,52	2,426	4,76	0°	0,4
WN•A 06 04 08	9,525	3,81	6,52	2,203	4,76	0°	0,8
WN•A 06 04 12	9,525	3,81	6,52	1,980	4,76	0°	1,2
WN•A 08 04 04	12,7	5,16	8,69	3,307	4,76	0°	0,4
WN•A 08 04 08	12,7	5,16	8,69	3,084	4,76	0°	0,8
WN•A 08 04 12	12,7	5,16	8,69	2,862	4,76	0°	1,2

5.12 Insert shape W without fixing hole (inserts for turning)

See [Figure 12](#) and [Table 12](#).

NOTE For the dimensions of l_1 , see [Table 13](#).

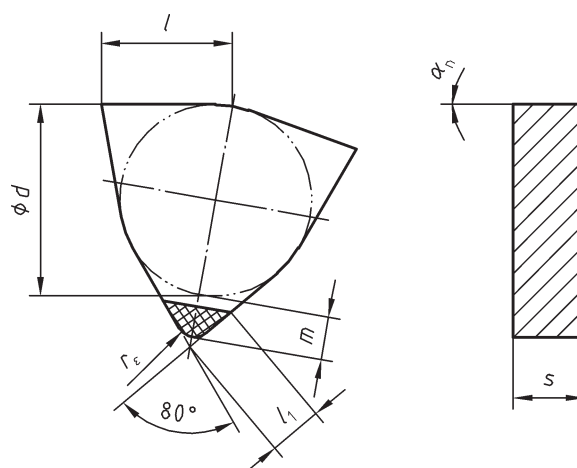

Figure 12

Table 12

Designation	d	l \approx	m	s	α_n	r_ϵ
WN•N 06 04 04	9,525	6,52	2,426	4,76	0°	0,4
WN•N 06 04 08	9,525	6,52	2,203	4,76	0°	0,8
WN•N 06 04 12	9,525	6,52	1,980	4,76	0°	1,2
WN•N 08 04 04	12,7	8,69	3,307	4,76	0°	0,4
WN•N 08 04 08	12,7	8,69	3,084	4,76	0°	0,8
WN•N 08 04 12	12,7	8,69	2,862	4,76	0°	1,2

6 Cutting edge length, l_1 , of tipped inserts

6.1 General

l_1 is defined as the length along the major cutting edge from the end of the tip to the furthest point perpendicular to the major cutting edge.

6.2 Inserts with radius

See [Figure 13](#).

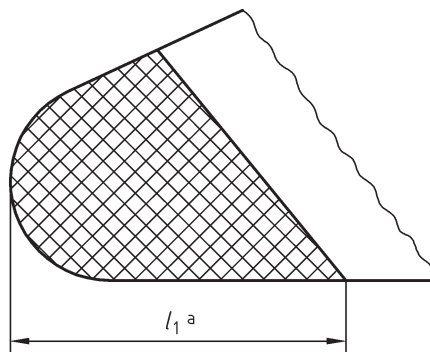

^a For the dimensions of l_1 , see [Table 13](#).

Figure 13

6.3 Inserts with wiper edge

See [Figure 14](#).

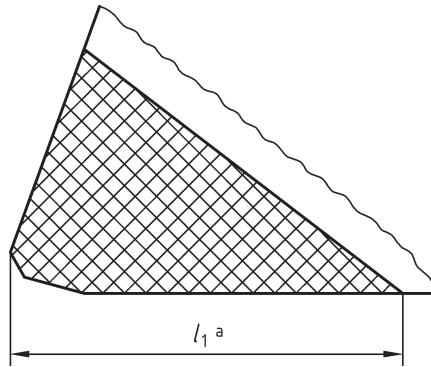

a For the dimensions of l_1 , see [Table 13](#).

Figure 14

Table 13

Cutting edge length	
l_1 min	
short	long
0,8	3,0

7 Base material, cutting material

Base material is selected at the manufacturer's option or upon agreement.

Cutting edges made of BL, BH, BC are in accordance with ISO 513.

8 Measurements

Measurements are taken in accordance with ISO 3365 and ISO 6987.

9 Marking

Indexable inserts shall be visibly and durably marked with

- the symbol for the corner radius r_ϵ ,
- the group of chip removal and group of application in accordance with ISO 513 or the cutting material grade, and
- the name or trademark of the manufacturer.

Additional marking is at the manufacturer's option or upon agreement. Different marking is upon agreement.

If there is no sufficient space on the indexable insert to indicate the group of chip removal, group of application, and the manufacturer's name, the insert can be marked with the manufacturer's cutting material grade instead. However, in such cases, the group of chip removal and group of application shall be indicated clearly and visibly on the packaging.

Annex A (informative)

Relationship between designations in ISO 16462 and ISO/ TS 13399-2

For the relationship between designations in this International Standard and preferred symbols according to ISO/TS 13399-2, see [Table A.1](#).

Table A.1 — Relationship between designations in ISO 16462 and ISO/TS 13399-2

Symbol in ISO 16462	Reference in ISO 16462	Property name in ISO/TS 13399-2	Symbol in ISO/TS 13399-2	Reference in ISO/TS 13399-2
α_n	3.2 , 4.2.1 , 4.2.2 , 4.3	clearance angle major	AN	BSU: 71DD70308D3E3
r_ϵ	3.3 , 4.2.1 , 4.2.2	corner radius	RE	BSU: 71DD6C8ACA503
—	3.4 , 4.2.1 , 4.2.2 , 4.3	tolerance class insert	TC	BSU: 71CE7AA215888
—	3.6	tipped cutting edge code	TCE	BSU: 71CE7AA1E3D75
ϵ_r	4.2.1 , 4.2.2	insert included angle	EPSR	BSU: 71CE7A96BC122
l	4.2.1 , 4.2.2 , 4.3	cutting edge length	L	BSU: 71DD6C95DA49B
s	4.2.1 , 4.2.2 , 4.3	insert thickness	S	BSU: 71CE7A9F5308C
κ_r	4.3	cutting edge angle major	KRINS	BSU: 71CE7AA02C1CC
α and α'_n	4.3 , Figures 6, 7 , Tables 6, 7	clearance angle wiper edge	AS	BSU: 71DD7031A98E9
—	4.3	insert hand	IH	BSU: 71CE7A979F41C
d	Figures 1, 2, 3, 4, 5, 6 , Tables 1, 2, 3, 4, 5, 6, 7, 8, 9, 10, 11, 12	inscribed circle diameter	IC	BSU: 71CE7A96D9F7D
d_1	Figures 1, 2, 3, 4, 5, 6 , Tables 1, 2, 3, 4, 5, 6, 7, 11	fixing hole diameter	D1	BSU: 71CE7A968C8FE
m	Figures 1, 2, 4, 5, 6, 7, 8 , Tables 1, 2, 4, 5, 6, 7, 8, 9, 10, 11, 12	m-dimension	M	BSU: 71CE7AA0972DB
m_1	Figures 3, 8 , Tables 3, 8	m-dimension	M	BSU: 71CE7AA0972DB
M_2	Figures 3, 8 , Tables 3, 8	m ₂ -dimension	M2	BSU: 71CE7AA05C819
l_1	Figures 1, 2, 3, 4, 5, 6, 7, 11, 12, 13, 14	cutting edge effective length	LE	BSU: 71DD6C958C615
37,5° and 45°	Figures 6, 7, 9	corner chamfer angle	KCH	BSU: 71DD6C88F9210
1,4	Figures 6, 7	wiper edge length	BS	BSU: 71CE7AA249F88

Table A.1 (continued)

Symbol in ISO 16462	Reference in ISO 16462	Property name in ISO/TS 13399-2	Symbol in ISO/TS 13399-2	Reference in ISO/TS 13399-2
1,124 and 0,7	Figures 6, 9	corner chamfer length	BCH	BSU: 71DD6C895C25B
0,2	Figure 7	corner chamfer width	CHW	BSU: 71DD6C89A120F

British Standards Institution (BSI)

BSI is the national body responsible for preparing British Standards and other standards-related publications, information and services.

BSI is incorporated by Royal Charter. British Standards and other standardization products are published by BSI Standards Limited.

About us

We bring together business, industry, government, consumers, innovators and others to shape their combined experience and expertise into standards-based solutions.

The knowledge embodied in our standards has been carefully assembled in a dependable format and refined through our open consultation process. Organizations of all sizes and across all sectors choose standards to help them achieve their goals.

Information on standards

We can provide you with the knowledge that your organization needs to succeed. Find out more about British Standards by visiting our website at bsigroup.com/standards or contacting our Customer Services team or Knowledge Centre.

Buying standards

You can buy and download PDF versions of BSI publications, including British and adopted European and international standards, through our website at bsigroup.com/shop, where hard copies can also be purchased.

If you need international and foreign standards from other Standards Development Organizations, hard copies can be ordered from our Customer Services team.

Subscriptions

Our range of subscription services are designed to make using standards easier for you. For further information on our subscription products go to bsigroup.com/subscriptions.

With **British Standards Online (BSOL)** you'll have instant access to over 55,000 British and adopted European and international standards from your desktop. It's available 24/7 and is refreshed daily so you'll always be up to date.

You can keep in touch with standards developments and receive substantial discounts on the purchase price of standards, both in single copy and subscription format, by becoming a **BSI Subscribing Member**.

PLUS is an updating service exclusive to BSI Subscribing Members. You will automatically receive the latest hard copy of your standards when they're revised or replaced.

To find out more about becoming a BSI Subscribing Member and the benefits of membership, please visit bsigroup.com/shop.

With a **Multi-User Network Licence (MUNL)** you are able to host standards publications on your intranet. Licences can cover as few or as many users as you wish. With updates supplied as soon as they're available, you can be sure your documentation is current. For further information, email bsmusales@bsigroup.com.

BSI Group Headquarters

389 Chiswick High Road London W4 4AL UK

Revisions

Our British Standards and other publications are updated by amendment or revision.

We continually improve the quality of our products and services to benefit your business. If you find an inaccuracy or ambiguity within a British Standard or other BSI publication please inform the Knowledge Centre.

Copyright

All the data, software and documentation set out in all British Standards and other BSI publications are the property of and copyrighted by BSI, or some person or entity that owns copyright in the information used (such as the international standardization bodies) and has formally licensed such information to BSI for commercial publication and use. Except as permitted under the Copyright, Designs and Patents Act 1988 no extract may be reproduced, stored in a retrieval system or transmitted in any form or by any means – electronic, photocopying, recording or otherwise – without prior written permission from BSI. Details and advice can be obtained from the Copyright & Licensing Department.

Useful Contacts:

Customer Services

Tel: +44 845 086 9001

Email (orders): orders@bsigroup.com

Email (enquiries): cservices@bsigroup.com

Subscriptions

Tel: +44 845 086 9001

Email: subscriptions@bsigroup.com

Knowledge Centre

Tel: +44 20 8996 7004

Email: knowledgecentre@bsigroup.com

Copyright & Licensing

Tel: +44 20 8996 7070

Email: copyright@bsigroup.com



...making excellence a habit.™