

BS ISO 16143-2:2014



BSI Standards Publication

Stainless steels for general purposes

Part 2: Corrosion-resistant semi-finished products, bars, rods and sections

bsi.

...making excellence a habit.™

National foreword

This British Standard is the UK implementation of ISO 16143-2:2014.

The UK participation in its preparation was entrusted to Technical Committee ISE/105, Steels for Heat Treatment, Alloy Steels, Free-Cutting Steels and Stainless Steels.

A list of organizations represented on this committee can be obtained on request to its secretary.

This publication does not purport to include all the necessary provisions of a contract. Users are responsible for its correct application.

© The British Standards Institution 2014.
Published by BSI Standards Limited 2014

ISBN 978 0 580 76080 8
ICS 77.140.20

Compliance with a British Standard cannot confer immunity from legal obligations.

This British Standard was published under the authority of the Standards Policy and Strategy Committee on 31 May 2014.

Amendments/corrigenda issued since publication

Date	Text affected
------	---------------

**Stainless steels for general
purposes —**

Part 2:
**Corrosion-resistant semi-finished
products, bars, rods and sections**

Aciers inoxydables pour usage général —

*Partie 2: Demi-produits, barres, fils machine et profils en acier
résistant à la corrosion*





COPYRIGHT PROTECTED DOCUMENT

© ISO 2014

All rights reserved. Unless otherwise specified, no part of this publication may be reproduced or utilized otherwise in any form or by any means, electronic or mechanical, including photocopying, or posting on the internet or an intranet, without prior written permission. Permission can be requested from either ISO at the address below or ISO's member body in the country of the requester.

ISO copyright office
Case postale 56 • CH-1211 Geneva 20
Tel. + 41 22 749 01 11
Fax + 41 22 749 09 47
E-mail copyright@iso.org
Web www.iso.org

Published in Switzerland

Contents

Page

Foreword	iv
1 Scope	1
2 Normative references	1
3 Terms and definitions	2
4 Designation	2
5 Information to be supplied by the purchaser	2
6 Classification of grades	3
7 Requirements	3
7.1 Manufacturing process	3
7.2 Delivery condition	3
7.3 Chemical composition	3
7.4 Susceptibility to intergranular corrosion	4
7.5 Mechanical properties	4
7.6 Surface quality	4
7.7 Internal soundness	5
7.8 Dimensions, tolerances on dimensions, and shape	5
8 Inspection, testing, and conformance of products	5
8.1 General	5
8.2 Inspection and testing procedures and types of inspection documents	5
8.3 Specific inspection and testing	6
8.4 Test methods	6
8.5 Retests	7
9 Marking	7
Annex A (informative) Guidelines for further treatment (including heat treatment) in fabrication	29
Annex B (informative) Designations of the steels given in Table 2 and of comparable grades covered in ASTM, EN, JIS, and GB Standards	34
Annex C (informative) Applicable dimensional standards	37
Bibliography	38

Foreword

ISO (the International Organization for Standardization) is a worldwide federation of national standards bodies (ISO member bodies). The work of preparing International Standards is normally carried out through ISO technical committees. Each member body interested in a subject for which a technical committee has been established has the right to be represented on that committee. International organizations, governmental and non-governmental, in liaison with ISO, also take part in the work. ISO collaborates closely with the International Electrotechnical Commission (IEC) on all matters of electrotechnical standardization.

The procedures used to develop this document and those intended for its further maintenance are described in the ISO/IEC Directives, Part 1. In particular the different approval criteria needed for the different types of ISO documents should be noted. This document was drafted in accordance with the editorial rules of the ISO/IEC Directives, Part 2 (see www.iso.org/directives).

Attention is drawn to the possibility that some of the elements of this document may be the subject of patent rights. ISO shall not be held responsible for identifying any or all such patent rights. Details of any patent rights identified during the development of the document will be in the Introduction and/or on the ISO list of patent declarations received (see www.iso.org/patents).

Any trade name used in this document is information given for the convenience of users and does not constitute an endorsement.

For an explanation on the meaning of ISO specific terms and expressions related to conformity assessment, as well as information about ISO's adherence to the WTO principles in the Technical Barriers to Trade (TBT) see the following URL: [Foreword - Supplementary information](#)

The committee responsible for this document is ISO/TC 17, *Steel*, Subcommittee SC 4, *Heat treatable and alloy steels*.

This second edition cancels and replaces the first edition (ISO 16143-2:2004), which has been technically revised.

ISO 16143 consists of the following parts, under the general title *Stainless steels for general purposes*:

- *Part 1: Corrosion-resistant flat products*
- *Part 2: Corrosion-resistant semi-finished products, bars, rods and sections*
- *Part 3: Wire*

Stainless steels for general purposes —

Part 2:

Corrosion-resistant semi-finished products, bars, rods and sections

1 Scope

This part of ISO 16143 specifies the technical delivery conditions for semi-finished products, hot formed bars, rods, and sections for general purposes made of the most important corrosion-resistant stainless steel grades.

NOTE 1 Throughout this part of ISO 16143, the term “general purposes” means purposes other than the special purposes mentioned in the Bibliography.

NOTE 2 Heat-resistant steel grades can be found in ISO 4955 and they can be used for corrosion-resistant purposes.

In addition to this part of ISO 16143, the general technical delivery requirements of ISO 404 are applicable.

This part of ISO 16143 does not apply to components manufactured by further processing the product forms listed in the first paragraph above with quality characteristics altered as a result of such further processing.

2 Normative references

The following documents, in whole or in part, are normatively referenced in this document and are indispensable for its application. For dated references, only the edition cited applies. For undated references, the latest edition of the referenced document (including any amendments) applies.

ISO 148-1, *Metallic materials — Charpy pendulum impact test — Part 1: Test method*

ISO 377, *Steel and steel products — Location and preparation of samples and test pieces for mechanical testing*

ISO 404, *Steel and steel products — General technical delivery requirements*

ISO 3651-2, *Determination of resistance to intergranular corrosion of stainless steels — Part 2: Ferritic, austenitic and ferritic-austenitic (duplex) stainless steels — Corrosion test in media containing sulfuric acid*

ISO 6506-1, *Metallic materials — Brinell hardness test — Part 1: Test method*

ISO 6892-1:2009, *Metallic materials — Tensile testing — Part 1: Method of test at room temperature*

ISO 6892-2, *Metallic materials — Tensile testing — Part 2: Method of test at elevated temperature*

ISO 6929, *Steel products — Vocabulary*

ISO 9443, *Heat-treatable and alloy steels — Surface quality classes for hot-rolled round bars and wire rods — Technical delivery conditions*

ISO 10474, *Steel and steel products — Inspection documents*

ISO 14284, *Steel and iron — Sampling and preparation of samples for the determination of chemical composition*

ISO 15510, *Stainless steels — Chemical composition*

ISO 20723, *Structural steels — Surface condition of hot-rolled sections — Delivery requirements*

ISO/TS 4949, *Steel names based on letter symbols*

ISO/TR 9769, *Steel and iron — Review of available methods of analysis*

3 Terms and definitions

For the purposes of this document, the terms and definitions given in ISO 6929 and the following apply.

3.1
corrosion-resistant stainless steel
steel with at least 10,5 % (mass fraction) Cr and a maximum of 1,2 % (mass fraction) C for which resistance to corrosion is of primary importance

3.2
product form
shape of a product

Note 1 to entry: See ISO 6929 for different forms of products.

4 Designation

For the steel grades covered by this part of ISO 16143, the steel names as given in the tables are allocated in accordance with ISO/TS 4949.

For the steel grades covered by this part of ISO 16143, the steel numbers as given in the tables are allocated in accordance with ISO 15510.

5 Information to be supplied by the purchaser

It shall be the responsibility of the purchaser to specify all requirements that are necessary for products under this part of ISO 16143. Such requirements to be considered include, in the order listed but not limited to, the following:

- a) the desired quantity;
- b) the product form (e.g. square bar or round rod);
- c) the number of the appropriate dimensional standard (see [Annex C](#)), the nominal dimensions, plus any choice of requirements;
- d) the type of material (steel);
- e) the number of this part of ISO 16143 (i.e. ISO 16143-2);
- f) the steel name or steel number;
- g) if, for the relevant steel in [Tables 5 to 9](#) for the mechanical properties, more than one treatment condition is covered, the symbol for the desired heat treatment;
- h) the desired process route (see symbols in [Table 4](#));
- i) if a verification of internal soundness is required, the requirements have to be agreed at the time of enquiry and order;
- j) any further optional test agreed between the manufacturer and purchaser at the time of enquiry and order [see [8.2.3 b](#)];

k) the type of inspection document and its designation in accordance with ISO 10474 (see [8.2.1](#)).

EXAMPLE 10 t round bar in accordance with ISO 1035-1 and ISO 1035-4 of 50 mm diameter made of a steel grade with name X5CrNi18-10 and number 4301-304-00-I as specified in ISO 16143-2 in process route 1D, inspection certificate 3.1 as specified in ISO 10474, is designated as follows:

10 t round bar ISO 1035-1 and -4 - 50
Steel ISO 16143-2 - X5CrNi18-10 + 1D
ISO 10474 - 3.1

or

10 t round bar ISO 1035-1 and -4 - 50
Steel ISO 16143-2 - 4301-304-00-I + 1D
ISO 10474 - 3.1

6 Classification of grades

Corrosion-resistant stainless steels covered by this part of ISO 16143 are classified according to their structure into

- austenitic steels,
- austenitic-ferritic steels,
- ferritic steels,
- martensitic steels, or
- precipitation-hardening steels.

7 Requirements

7.1 Manufacturing process

Unless a special steelmaking process is agreed upon when ordering, the steelmaking process shall be at the discretion of the manufacturer. When he so requests, the purchaser shall be informed what steelmaking process is being used.

7.2 Delivery condition

The products shall be supplied in the delivery condition agreed in the order by reference to the process route given in [Table 4](#) and, where different alternatives exist, to the treatment conditions given in [Tables 5 to 9](#) (see also [Annex A](#)).

7.3 Chemical composition

7.3.1 The chemical composition requirements given in [Table 2](#) apply with respect to the chemical composition of the cast analysis.

7.3.2 The product analysis can deviate from the limiting values for the cast analysis given in [Table 2](#) by the values listed in [Table 3](#).

7.4 Susceptibility to intergranular corrosion

Referring to resistance to intergranular corrosion as defined in ISO 3651-2, for austenitic, austenitic-ferritic, and ferritic steels, the specifications in [Tables 5, 6, and 7](#) apply.

The susceptibility of stainless steels to intergranular corrosion is dependent on the type of environment and therefore cannot always be clearly ascertained through standard laboratory tests. The selection of the test or tests to be agreed upon should be based on experience with the use of the selected grade of steel in the intended environment.

7.5 Mechanical properties

The mechanical properties at room temperature as specified in [Tables 5 to 9](#) apply for the relevant specified heat-treatment condition. This does not apply to process route 1U (hot rolled, not heat treated, not descaled). If, by agreement at the time of ordering, the products are to be supplied in a non-heat-treated condition, the mechanical properties specified in [Tables 5 to 9](#) shall be obtainable from reference test pieces that have received the appropriate heat treatment (simulated heat treatment).

The values in [Tables 10 to 14](#) apply for the 0,2 %- and 1 %-proof strength at elevated temperatures.

NOTE Austenitic steels are insensitive to brittle fracture in the solution-annealed condition. Because they do not have a pronounced transition temperature, which is characteristic of other steels, they are also useful for application at cryogenic temperatures.

7.6 Surface quality

The available surface finishes are given in [Table 4](#). Slight surface imperfections, inherent to the production process, are permitted. Exact requirements concerning the maximum depth of acceptable discontinuities for bars, rods, and sections in the relevant conditions are given in [Table 1](#).

Table 1 — Maximum depth of acceptable discontinuities for bars, rods, and sections

Conditions	Product forms	Permissible depth of discontinuities ^a	Max. % of delivered weight in excess of permissible depth of discontinuities
1U, 1C, 1E, 1D	Sections	To be agreed upon at the time of enquiry and order on the basis of ISO 20723.	
1U, 1C, 1E, 1D	Rounds and rod	Unless not specified otherwise at the time of enquiry and order, ISO 9443 class 1 za2.	
1X ^b	Rounds	— max. 0,2 mm for $d \leq 20$ mm — max. 0,01 d for $20 \text{ mm} < d \leq 75$ mm — max. 0,75 mm for $d > 75$ mm	1 %
	Hexagons	— max. 0,3 mm for $d \leq 15$ mm — max. 0,02 d for $15 \text{ mm} < d \leq 63$ mm	2 %
	Other bars	— max. 0,3 mm for $d \leq 15$ mm — max. 0,02 d for $15 \text{ mm} < d \leq 63$ mm	4 %
1G	Rounds	Technically defect free by manufacture.	0,2 %
^a Depth of discontinuities is understood as being the distance, measured normally to the surface, between the bottom of the discontinuities and that surface. ^b At the time of enquiry and order, it can be agreed that the product shall be delivered with a surface that is technically defect free by manufacture. In this case, also the maximum % of delivered weight in excess of permissible depth of discontinuities shall be agreed.			

For further information, see [Table 4](#).

7.7 Internal soundness

For internal soundness, where appropriate, any requirements, together with the conditions for their verification, can be agreed upon at the time of enquiry and order.

7.8 Dimensions, tolerances on dimensions, and shape

The dimensions and the tolerances on dimensions and shape are to be agreed upon at the time of enquiry and order, as far as possible with reference to the dimensional standards listed in [Annex C](#).

8 Inspection, testing, and conformance of products

8.1 General

The manufacturer shall carry out appropriate process control, inspection, and testing to ensure that the delivery complies with the requirements of the order.

This includes the following:

- a suitable frequency of verification of the dimensions of the products;
- an adequate intensity of visual examination of the surface quality of the products;
- an appropriate frequency and type of test to ensure that the correct grade of steel is delivered.

The nature and frequency of these verifications, examinations, and tests are determined by the manufacturer, based on the degree of consistency that has been determined by the evidence of his quality system. In view of this, verifications by specific tests for these requirements are not necessary unless otherwise agreed upon.

8.2 Inspection and testing procedures and types of inspection documents

8.2.1 Products complying with this part of ISO 16143 shall be ordered and delivered with one of the inspection documents as specified in ISO 10474. The type of document shall be agreed upon at the time of enquiry and order. If the order does not contain any specification of this type, a test report 2.2 shall be issued.

8.2.2 If, in accordance with the agreements made at the time of enquiry and order, a test report is to be provided, this shall cover

- a) a statement that the material complies with the requirements of the order and
- b) the results of the cast analysis for all elements specified for the type of steel supplied.

8.2.3 If, in accordance with the agreements in the order, an inspection certificate 3.1 or 3.2 is to be provided, the specific inspections and tests described in [8.3](#) shall be carried out and their results shall be certified in the document.

In addition to [8.2.2](#), the document shall cover

- a) the results of the mandatory tests marked in the second column of [Table 15](#) by an “m” and
- b) the results of any optional test or inspections agreed upon when ordering marked in the second column of [Table 15](#) by an “o”.

8.3 Specific inspection and testing

8.3.1 Extent of testing

The tests to be carried out, either mandatorily (m) or by agreement (o), and the composition and size of the test units, and the number of sample products, samples, and test pieces to be taken are given in [Table 15](#).

8.3.2 Selection and preparation of samples and test pieces

8.3.2.1 The general conditions for selection and preparation of samples and test pieces shall be in accordance with ISO 377 and ISO 14284.

8.3.2.2 The samples for the tensile test shall be taken in accordance with [Figures 1 to 3](#).

The samples shall be taken from products in the as-delivered condition. If agreed, samples from bars can be taken before straightening. For martensitic and precipitation-hardened grades being delivered in the annealed condition, a test to demonstrate the capability of further treatment to one of the specified conditions shall be conducted by the manufacturer on a sample taken from the product in the as-delivered condition and further treated in accordance with a listed production route. Unless specified in the order, that final condition and details of conditions of further treatment shall be at the option of the manufacturer.

8.3.2.3 Samples for the hardness test and for the resistance to intergranular corrosion test, where requested, shall be taken from the same locations as those for the mechanical tests.

8.4 Test methods

8.4.1 Unless otherwise agreed when ordering, the choice of a suitable physical or chemical method of analysis to determine the product analysis is at the discretion of the manufacturer. In cases of dispute, the analysis shall be carried out by a laboratory approved by the two parties. In these cases, the reference method of analysis shall be agreed upon, where possible, with reference to ISO/TR 9769.

8.4.2 The tensile test shall be carried out in accordance with ISO 6892-1 and it shall be performed under controlled conditions in accordance with Clause 5 of ISO 6892-1:2009.

Unless otherwise agreed, the tensile strength and elongation after fracture shall be determined and, in addition, for ferritic, martensitic, precipitation-hardening, austenitic free-cutting, and austenitic-ferritic steels, the 0,2 %-proof strength, and for austenitic steels, the 0,2 %- and 1 %-proof strength.

For bars made of resulfurized grades, it can be agreed upon to determine the hardness instead.

If a tensile test at elevated temperature has been ordered, this shall be carried out in accordance with ISO 6892-2. If the proof strength is to be verified, the 0,2 %-proof strength shall be determined, for ferritic, martensitic, precipitation-hardening, and austenitic-ferritic steels. In the case of austenitic steels, the 0,2 %- and the 1 %-proof strength shall be determined.

8.4.3 If an impact test has been ordered, it shall be carried out in accordance with ISO 148-1 on test pieces with a V-notch and a 2 mm hammer. The average obtained from three test pieces is considered to be the test result (see also ISO 404).

8.4.4 The Brinell hardness test shall be carried out in accordance with ISO 6506-1.

8.4.5 The resistance to intergranular corrosion shall be tested in accordance with ISO 3651-2, unless otherwise agreed.

8.4.6 Dimensions and dimensional tolerances of the products shall be tested in accordance with the requirements of the relevant dimensional standards given in [Annex C](#).

8.5 Retests

See ISO 404.

9 Marking

9.1 The products shall be marked with the manufacturer's trademark or symbol and the steel name or number. The product shall also be marked with the cast number, thickness, or dimension, as well as an identification number related to an appropriate inspection certificate.

9.2 Unless otherwise agreed, the method of marking and the material of marking shall be at the option of the manufacturer. Its quality shall be such that it shall be durable for at least one year, can withstand normal handling, and can be stored in unheated storage under cover. The corrosion resistance of the product shall not be impaired by the marking.

9.3 Each unit shall be marked:

- for semi-finished products, bars, and sections, by means of labels attached to the bundle or, by agreement at the time of enquiry and order, by inking, adhesive labels, electrolytic etching, or stamping;
- for rods, by means of a label attached to the coil.

Table 2 — Chemical composition (cast analysis)

Steel designation		% (mass fraction) ^a										
Name	ISO number	C	Si	Mn	P	S	Cr	Mo	Ni	N	Others	
Austenitic steels												
X10CrNi18-8	4310-301-00-1	0,05 to 0,15	2,00	2,00	0,045	0,030	16,0 to 19,0	0,80	6,0 to 9,5	0,10	—	
X2CrNi18-9	4307-304-03-1	0,030	1,00	2,00	0,045	0,030	17,5 to 19,5	—	8,0 to 10,0 ^b	0,10	—	
X10CrNiS18-9	4305-303-00-1	0,12	1,00	2,00	0,060	≥0,15	17,0 to 19,0	—	8,0 to 10,0	0,10	Cu: ^c	
X2CrNiN18-9	4311-304-53-1	0,030	1,00	2,00	0,045	0,030	17,5 to 19,5	—	8,0 to 10,0	0,12 to 0,22	—	
X3CrNiCu18-9-4	4567-304-30-1	0,04	1,00	2,00	0,045	0,030	17,0 to 19,0	—	8,0 to 10,5	0,10	Cu: 3,0 to 4,0	
X6CrNiCuS18-9-2	4570-303-31-1	0,08	1,00	2,00	0,045	≥0,15	17,0 to 19,0	0,60	8,0 to 10,0	0,10	Cu: 1,40 to 1,80	
X5CrNiN19-9	4315-304-51-1	0,08	1,00	2,50	0,045	0,030	18,0 to 20,0	—	7,0 to 10,5	0,10 to 0,30	— ^d	
X5CrNi18-10	4301-304-00-1	0,07	1,00	2,00	0,045	0,030	17,5 to 19,5	—	8,0 to 10,5 ^b	0,10	—	
X6CrNiTi18-10	4541-321-00-1	0,08	1,00	2,00	0,045	0,030	17,0 to 19,0	—	9,0 to 12,0 ^b	—	Ti: 5 × C to 0,70	
X6CrNiNb18-10	4550-347-00-1	0,08	1,00	2,00	0,045	0,030	17,0 to 19,0	—	9,0 to 12,0 ^b	—	Nb: 10 × C to 1,00	
X2CrNi19-11	4306-304-03-1	0,030	1,00	2,00	0,045	0,030	18,0 to 20,0	—	10,0 to 12,0 ^b	0,10	—	
X6CrNi18-12	4303-305-00-1	0,08	1,00	2,00	0,045	0,030	17,0 to 19,0	—	10,5 to 13,0	0,10	—	

Table 2 — (continued)

Steel designation		% (mass fraction) ^a										
Name	ISO number	C	Si	Mn	P	S	Cr	Mo	Ni	N	Others	
X8CrMnCuN17-8-3	4597-204-76-1	0,10	2,00	6,5 to 9,0	0,040	0,030	15,0 to 18,0	1,00	3,00	0,10 to 0,30	Cu: 2,00 to 3,5	
X3CrMnNiCu15-8-5-3g	4615-201-75-Eg	0,030	1,00	7,0 to 9,0	0,040	0,010	14,0 to 16,0	0,80	4,5 to 6,0	0,02 to 0,06	Cu: 2,0 to 4,0	
X12CrMnNiN18-9-5	4373-202-00-1	0,15	1,00	7,5 to 10,0	0,060	0,030	17,5 to 19,0	—	4,0 to 6,0	0,15 to 0,30	—	
X11CrNiMnN19-8-6	4369-202-91-1	0,07 to 0,15	0,50 to 1,00	5,0 to 7,5	0,030	0,015	17,5 to 19,5	—	6,5 to 8,5	0,20 to 0,30	—	
X1CrNi25-21	4335-310-02-1	0,020	0,25	2,00	0,025	0,010	24,0 to 26,0	0,20	20,0 to 22,0	0,10	—	
Austenitic steels with Mo												
X2CrNiMo17-12-2	4404-316-03-1	0,030	1,00	2,00	0,045	0,030	16,5 to 18,5	2,00 to 3,00	10,0 to 13,0 ^b	0,10	—	
X5CrNiMo17-12-2	4401-316-00-1	0,07	1,00	2,00	0,045	0,030	16,5 to 18,5	2,00 to 3,00	10,0 to 13,0 ^b	0,10	—	
X6CrNiMoTi17-12-2	4571-316-35-1	0,08	1,00	2,00	0,045	0,030	16,5 to 18,5	2,00 to 2,50	10,5 to 13,5 ^b	—	Ti: 5 × C to 0,70	
X2CrNiMo17-12-3	4432-316-03-1	0,030	1,00	2,00	0,045	0,030	16,5 to 18,5	2,50 to 3,00	10,5 to 13,0 ^b	0,10	—	
X3CrNiMo17-12-3	4436-316-00-1	0,05	1,00	2,00	0,045	0,030	16,5 to 18,5	2,50 to 3,00	10,5 to 13,0 ^b	0,10	—	
X2CrNiMoN17-12-3	4429-316-53-1	0,030	1,00	2,00	0,045	0,030	16,5 to 18,5	2,50 to 3,00	10,5 to 13,0 ^b	0,12 to 0,22	—	
X2CrNiMo18-14-3	4435-316-91-1	0,030	1,00	2,00	0,045	0,015	17,0 to 19,0	2,50 to 3,00	12,5 to 15,0	0,10	—	
X2CrNiMoN18-12-4	4434-317-53-1	0,030	1,00	2,00	0,045	0,030	16,5 to 19,5	3,0 to 4,0	10,5 to 14,0 ^b	0,10 to 0,20	—	
X2CrNiMoN17-13-5	4439-317-26-E	0,030	1,00	2,00	0,045	0,015	16,5 to 18,5	4,0 to 5,0	12,5 to 14,5	0,12 to 0,22	—	
X1CrNiMoCuN20-18-7	4547-312-54-1	0,020	0,70	1,00	0,035	0,015	19,5 to 20,5	6,0 to 7,0	17,5 to 18,5	0,18 to 0,25	Cu: 0,50 to 1,00	

Table 2 — (continued)

Steel designation		% (mass fraction) ^a										
Name	ISO number	C	Si	Mn	P	S	Cr	Mo	Ni	N	Others	
X1CrNiMoN25-22-2	4466-310-50-E	0,020	0,70	2,00	0,025	0,010	24,0 to 26,0	2,00 to 2,50	21,0 to 23,0	0,10 to 0,16	—	
X1CrNiMoCuNW24-22-6	4659-312-66-I	0,020	0,70	2,0 to 4,0	0,030	0,010	23,0 to 25,0	5,5 to 6,5	21,0 to 23,0	0,35 to 0,50	Cu: 1,00 to 2,00 W: 1,50 to 2,50	
X1CrNiMoCuN24-22-8	4652-326-54-I	0,020	0,50	2,0 to 4,0	0,030	0,005	23,0 to 25,0	7,0 to 8,0	21,0 to 23,0	0,45 to 0,55	Cu: 0,30 to 0,60	
X2CrNiMnMoN25-18-6-5	4565-345-65-I	0,030	1,00	5,0 to 7,0	0,030	0,015	24,0 to 26,0	4,0 to 5,0	16,0 to 19,0	0,30 to 0,60	Nb: 0,15	
Austenitic steels with Ni/Co as main alloying elements												
X1NiCrMoCu25-20-5	4539-089-04-I	0,020	0,75	2,00	0,035	0,015	19,0 to 22,0	4,0 to 5,0	23,5 to 26,0	0,15	Cu: 1,20 to 2,00	
X1NiCrMoCuN25-20-7	4529-089-26-I	0,020	0,75	2,00	0,035	0,015	19,0 to 21,0	6,0 to 7,0	24,0 to 26,0	0,15 to 0,25	Cu: 0,50 to 1,50	
X1NiCrMoCu31-27-4	4563-080-28-I	0,020	0,70	2,00	0,030	0,010	26,0 to 28,0	3,0 to 4,0	30,0 to 32,0	0,10	Cu: 0,70 to 1,50	
Austenitic-ferritic steels												
X2CrNiN22-2g	4062-322-02-Ug	0,030	1,00	2,00	0,040	0,010	21,5 to 24,0	0,45	1,00 to 2,90	0,16 to 0,28	—	
X2CrMnNiN21-5-1g	4162-321-01-Eg	0,040	1,00	4,0 to 6,0	0,040	0,015	21,0 to 22,0	0,10 to 0,80	1,35 to 1,90	0,20 to 0,25	Cu: 0,10 to 0,80	
X2CrNiN23-4	4362-323-04-I	0,030	1,00	2,00	0,035	0,015	22,0 to 24,5	0,10 to 0,60	3,5 to 5,5	0,05 to 0,20	Cu: 0,10 to 0,60	
X2CrNiMoN22-5-3g	4462-318-03-1g	0,030	1,00	2,00	0,035	0,015	21,0 to 23,0	2,5 to 3,5	4,5 to 6,5	0,10 to 0,22	—	
X2CrNiMnMoCuN24-4-3-2g	4662-824-41-Xg	0,030	0,70	2,50 to 4,0	0,035	0,005	23,0 to 25,0	1,00 to 2,00	3,0 to 4,5	0,20 to 0,30	Cu: 0,10 to 0,80	
X3CrNiMoN27-5-2	4460-312-00-I	0,050	1,00	2,00	0,035	0,015	25,0 to 28,0	1,30 to 2,00	4,5 to 6,5	0,05 to 0,20	—	
X2CrNiMoCuN25-6-3	4507-325-20-I	0,030	0,70	2,00	0,035	0,015	24,0 to 26,0	2,5 to 4,0	5,0 to 7,5	0,15 to 0,30	Cu: 1,00 to 2,50	
X2CrNiMoN25-7-4	4410-327-50-E	0,030	1,00	2,00	0,035	0,015	24,0 to 26,0	3,0 to 4,5	6,0 to 8,0	0,24 to 0,35	—	
X2CrNiMoCuWN25-7-4	4501-327-60-I	0,030	1,00	1,00	0,035	0,015	24,0 to 26,0	3,0 to 4,0	6,0 to 8,0	0,20 to 0,30	Cu: 0,50 to 1,00 W: 0,50 to 1,00	
X2CrNiMoCoN28-8-5-1g	4658-327-07-Ug	0,030	0,50	1,50	0,035	0,010	26,0 to 29,0	4,0 to 5,0	5,5 to 9,5	0,30 to 0,50	Cu: 1,00 Co: 0,50 to 2,00	

Table 2 — (continued)

Steel designation		% (mass fraction) ^a										
Name	ISO number	C	Si	Mn	P	S	Cr	Mo	Ni	N	Others	
Ferritic steels												
X6Cr13	4000-410-08-I	0,08 ^e	1,00	1,00	0,040	0,030 ^b	11,5 to 14,0	—	0,75	—	—	
X6Cr17	4016-430-00-I	0,08 ^e	1,00	1,00	0,040	0,030	16,0 to 18,0	—	—	—	—	
X7Cr17	4004-430-20-I	0,09	1,50	1,50	0,040	≥0,15	16,0 to 18,0	0,60	—	—	—	
X3CrNb17	4511-430-71-I	0,05	1,00	1,00	0,040	0,015	16,0 to 18,0	—	—	—	Nb: 12 × C to 1,00	
X2CrTiNb18	4509-439-40-X	0,030	1,00	1,00	0,040	0,015	17,5 to 18,5	—	—	—	Ti: 0,10 to 0,60 Nb: 0,30 + 3 × C to 1,00	
X6CrMo17-1	4113-434-00-I	0,08	1,00	1,00	0,040	0,030	16,0 to 18,0	0,90 to 1,40	—	—	—	
X2CrMoTiS18-2	4523-182-35-I	0,030	1,00	0,50	0,040	≥0,15	17,5 to 19,0	2,00 to 2,50	—	—	Ti: 0,30 to 0,80 (C + N): 0,040	
Martensitic steels												
X12Cr13	4006-410-00-I	0,08 to 0,15	1,00	1,50	0,040	0,030	11,5 to 13,5	—	0,75	—	—	
X12CrS13	4005-416-00-I	0,08 to 0,15	1,00	1,50	0,040	≥0,15	12,0 to 14,0	0,60	—	—	—	
X20Cr13	4021-420-00-I	0,16 to 0,25	1,00	1,50	0,040	0,030	12,0 to 14,0	—	—	—	—	
X30Cr13	4028-420-00-I	0,26 to 0,35	1,00	1,50	0,040	0,030	12,0 to 14,0	—	—	—	—	
X17CrNi16-2	4057-431-00-X	0,12 to 0,22	1,00	1,50	0,040	0,030	15,0 to 17,0	—	1,50 to 2,50	—	—	
X14CrS17	4019-430-20-I	0,10 to 0,17	1,00	1,50	0,040	≥0,15	16,0 to 18,0	0,60	—	—	—	
X110Cr17	4023-440-04-I	0,95 to 1,20	1,00	1,00	0,040	0,030	16,0 to 18,0	0,75	0,60	—	—	
X50CrMoV15	4116-420-77-E	0,45 to 0,55	1,00	1,00	0,040	0,015	14,0 to 15,0	0,50 to 0,80	—	—	V: 0,10 to 0,20	
X3CrNiMo13-4	4313-415-00-I	0,05	0,70	0,50 to 1,00	0,040	0,015	12,0 to 14,0	0,30 to 1,00	3,5 to 4,5	—	—	
X4CrNiMo16-5-1	4418-431-77-E	0,06	0,70	1,50	0,040	0,015	15,0 to 17,0	0,80 to 1,50	4,0 to 6,0	≥0,020	—	
X39CrMo17-1	4122-434-09-I	0,33 to 0,45	1,00	1,50	0,040	0,015	15,5 to 17,5	0,80 to 1,30	1,00	—	—	

Table 2 — (continued)

Steel designation		% (mass fraction) ^a									
Name	ISO number	C	Si	Mn	P	S	Cr	Mo	Ni	N	Others
Precipitation-hardening steels											
X5CrNiCuNb16-4	4542-174-00-1	0,07	0,70	1,50	0,040	0,030	15,0 to 17,0	0,60	3,0 to 5,0	—	Cu: 3,0 to 5,0 Nb: 5 × C to 0,45
X7CrNiAl17-7	4568-177-00-1	0,09	0,70	1,00	0,040	0,015	16,0 to 18,0	—	6,5 to 7,8 ^f	—	Al: 0,70 to 1,50
<p>NOTE Elements not listed in this table cannot be intentionally added to the steel without the agreement of the purchaser, except for finishing the cast. All appropriate precautions shall be taken to avoid the addition of such elements from scrap and other materials used in production, which would impair mechanical properties and the suitability of the steel.</p> <p>a Maximum values unless indicated otherwise.</p> <p>b Where, for special reasons (e.g. hot workability or low magnetic permeability), it is necessary to minimize the ferrite content, the maximum nickel mass fraction can be increased by the following amounts:</p> <ul style="list-style-type: none"> — by 0,50 % for steels X2CrNi18-9, X5CrNi18-10, and X6CrNiMoTi17-12-2; — by 1,00 % for steels X6CrNiTi18-10, X6CrNiNb18-10, X2CrNi19-11, X5CrNiMo17-12-2, X3CrNiMo17-12-3, X2CrNiMoN17-12-3, and X2CrNiMoN18-12-4; — by 1,50 % for steels X2CrNiMo17-12-2 and X2CrNiMo17-12-3. <p>c Copper can be added up to 1 %. If added, it shall be reported in the inspection document, provided such a document has been ordered.</p> <p>d Nb can be added up to 0,15 %.</p> <p>e For certain applications, e.g. weldability or high strength wire, a maximum of 0,12 % C can be agreed upon.</p> <p>f By special agreement, the steel, when intended for cold deformation, can also be ordered with 7,0 % to 8,3 % Ni.</p> <p>g Patented steel grade.</p>											

Table 3 — Permissible deviations between the product analysis and the limiting values given in [Table 2](#) for the cast analysis

Element	Specified limits, cast analysis % (mass fraction)		Permissible deviation ^a % (mass fraction)
Carbon		≤0,030	+0,005
	>0,030	≤0,20	±0,01
	>0,20	≤0,60	±0,02
	>0,60	≤1,20	±0,03
Silicon		≤1,00	+0,05
	>1,00	≤3,00	±0,10
	>3,00	≤6,00	±0,15
Manganese		≤1,00	+0,03
	>1,00	≤2,00	±0,04
	>2,00	≤15,0	±0,10
Phosphorus		≤0,045	+0,005
	>0,045	0,070	±0,010
Sulfur		≤0,015	+0,003
	>0,015	≤0,030	±0,005
	≥0,10	≤0,50	±0,02
Chromium	≥10,5	≤15,0	±0,15
	>15,0	≤20,0	±0,20
	>20,0	≤35,0	±0,25
Molybdenum		≤0,60	+0,03
	>0,60	≤1,75	±0,05
	>1,75	≤8,0	±0,10
Nickel		≤1,00	+0,03
	>1,00	≤5,0	±0,07
	>5,0	≤10,0	±0,10
	>10,0	≤20,0	±0,15
	>20,0	≤38,0	±0,20
Nitrogen		≤0,10	+0,01
	≥0,10	≤0,60	±0,02
Aluminium	≥0,05	≤0,30	±0,05
	>0,30	≤1,50	±0,10
Boron		≤0,010	+0,000 5
Copper		≤1,00	+0,04
	>1,00	≤5,0	±0,10
Niobium		≤1,00	+0,05
Titanium		≤1,00	+0,05
	>1,00	≤3,0	±0,07
Tungsten		≤3,00	+0,05
Vanadium		≤0,50	+0,03

^a ± means that in one cast, the deviation can occur over the upper value or under the lower value of the specified range in [Table 2](#), but not both at the same time.

Table 4 — Types of process routes and surface finish of long products^a

Condition	Abbreviation ^b	Type of process route	Surface finish	Product form			Notes
				Rods	Bars, sections	Semi finished	
Hot formed	1U	Hot formed, not heat treated, not descaled	Covered with scale (spot ground if necessary)	X	X	X	Suitable for products to be further hot formed. For semi-finished products, ground on all sides can be specified.
	1C	Hot formed, heat treated ^c , not descaled	Covered with scale (spot ground if necessary)	X	X	X	Suitable for products to be further processed. For semi-finished products, ground on all sides can be specified.
	1E	Hot formed, heat treated ^c , mechanically descaled	Largely free of scale (but some black spots might remain)	X	X	X	The type of mechanical descaling, e.g. grinding, peeling, or shot blasting, is left to the manufacturer's discretion unless otherwise agreed. Suitable for products to be further processed.
	1D	Hot formed, heat treated ^c , pickled	Free of scale	X	X	—	Tolerance ≥ IT 14 ^{de}
	1X	Hot formed, heat treated ^c , rough machined (rough turned)	Metallically clean	—	X	—	Tolerance ≥ IT 12 ^{de}
Special finishing process	1G	Centreless ground	Uniform finish; type and degree of grinding to be agreed	—	X	—	Surface roughness can be specified. Finish for close ISO tolerances. Normally obtained from material in finishes 1E, 1D, 2H, or 2B. Tolerance ≤ IT 8 ^{de}
	1P	Polished	Smoother and brighter than finish 1G or 2G; type and degree of polishing to be agreed	—	X	—	Surface roughness can be specified. Finish for close ISO tolerances. Normally obtained from material in finishes 1E, 1D, 2B, 1G, or 2H. Tolerance ≤ IT 11 ^{de}

^a Not all process routes and surface finishes are available for all steels.

^b First digit: 1 = hot formed, 2 = cold processed.

^c On ferritic, austenitic, and austenitic-ferritic grades, the heat treatment can be omitted if the conditions for hot forming and subsequent cooling are such that the requirements for the mechanical properties of the product and the resistance to intergranular corrosion are obtained.

^d For information: IT = international tolerance, as defined in ISO 286-1, and in other dimensional tolerance standards.

^e Specific tolerance within the ranges shall be agreed upon at the time of enquiry and order.

Table 5 — Mechanical properties at room temperature for austenitic steels in the solution-annealed condition (+AT) (see Table B.1)

Steel designation		Thickness <i>t</i> or diameter <i>d</i>	Proof strength ^a		Tensile strength	Elongation after fracture ^a		Impact energy (ISO-V)		Resistance to intergranular corrosion ^b	
Name	ISO number	mm	<i>R_{p0,2}</i>	<i>R_{p1,0}</i>	<i>R_m</i>	% min.		KV ₂		in the delivery condition	in the sensitized condition ^c
			MPa min.	MPa min.		long.	tr.	long.	tr.		
Austenitic steels											
X10CrNi18-8	4310-301-00-I	g	—	—	500 to 700	—	—	—	—	no	no

Table 5 (continued)

Steel designation		Thickness <i>t</i> or diameter <i>d</i> mm	Proof strength ^a		Tensile strength <i>R_m</i> MPa	Elongation after fracture ^a		Impact energy (ISO-V)		Resistance to intergranular corrosion ^b	
Name	ISO number		<i>R_{p0,2}</i> MPa min.	<i>R_{p1,0}</i> MPa min.		<i>A</i> % min.	long.	tr.	<i>KV₂</i> J min.	long.	tr.
X2CrNi18-9	4307-304-03-I	≤160	180	220	480 to 680	40 ^e	—	100	—	yes	yes
		160 < <i>t</i> ≤ 250				—	35	—	60		
X10CrNiS18-9	4305-303-00-I	≤160 ^d	190	^h	500 to 700	35 ^e	—	—	—	no	no
X2CrNiN18-9	4311-304-53-I	160	270	310	550 to 750	40 ^e	—	100	—	yes	yes
		160 < <i>t</i> ≤ 250				—	30	—	60		
X3CrNiCu18-9-4	4567-304-30-I	^g	—	—	450 to 650	—	—	—	—	yes	yes
X6CrNiCuS18-9-2	4570-303-31-I	≤160 ^d	185	220	500 to 710	35 ^e	—	—	—	no	no
X5CrNiN19-9	4315-304-51-I	≤40	270	310	550 to 750	40	—	100	—	yes	no ^f
X5CrNi18-10	4301-304-00-I	≤160	200	240	510 to 710	40 ^e	—	100	—	yes	no ^f
		160 < <i>t</i> ≤ 250				—	35	—	60		
X6CrNiTi18-10	4541-321-00-I	≤160	200	240	510 to 710	40 ^e	—	100	—	yes	yes
		160 < <i>t</i> ≤ 250				—	30	—	60		
X6CrNiNb18-10	4550-347-00-I	≤160	205	240	510 to 740	40 ^e	—	100	—	yes	yes
		160 < <i>t</i> ≤ 250				—	30	—	60		
X2CrNi19-11	4306-304-03-I	≤160	180	220	480 to 680	40 ^e	—	100	—	yes	yes
		160 < <i>t</i> ≤ 250	—	—		—	35	—	60		
X6CrNi18-12	4303-305-00-I	≤160	190	225	480 to 680	45	—	100	—	yes	no ^f
		160 < <i>t</i> ≤ 250				—	35	—	60		
X8CrMnCuN17-8-3	4597-204-76-I	≤160 ^d	270	305	560 to 760	40 ^e	—	100	—	yes	no
X3CrMn-NiCu15-8-5-3	4615-201-75-E	≤160	175	210	400 to 600	45	—	—	—	yes	yes
X12CrMnNiN18-9-5	4373-202-00-I	≤10 ^d	350	380	700 to 900	35 ^e	—	—	—	yes	no
X11CrNiMnN19-8-6	4369-202-91-I	≤15 ^d	340	370	750 to 950	35 ^e	—	—	—	yes	no
X1CrNi25-21	4335-310-02-I	^g	—	—	470 to 670	—	—	—	—	yes	yes
Austenitic steels with Mo											
X2CrNiMo17-12-2	4404-316-03-I	≤160	205	245	520 to 720	40	—	100	—	yes	yes
		160 < <i>t</i> ≤ 250				—	30	—	60		
X5CrNiMo17-12-2	4401-316-00-I	≤160	205	245	520 to 720	40 ^e	—	100	—	yes	no ^f
		160 < <i>t</i> ≤ 250				—	30	—	60		
X6CrNiMoTi17-12-2	4571-316-35-I	≤160	205	245	520 to 720	40 ^e	—	100	—	yes	yes
		160 < <i>t</i> ≤ 250				—	30	—	60		
X2CrNiMo17-12-3	4432-316-03-I	≤160	205	245	520 to 720	40 ^e	—	100	—	yes	yes
		160 < <i>t</i> ≤ 250				—	30	—	60		
X3CrNiMo17-12-3	4436-316-00-I	≤160	205	245	520 to 720	40 ^e	—	100	—	yes	no ^f
		160 < <i>t</i> ≤ 250				—	30	—	60		
X2CrNiMoN17-12-3	4429-316-53-I	≤ 60	280	315	580 to 800	40 ^e	—	100	—	yes	yes
		160 < <i>t</i> ≤ 250				—	30	—	60		
X2CrNiMo18-14-3	4435-316-91-I	≤160	200	235	500 to 700	40 ^e	—	100	—	yes	yes
		160 < <i>t</i> ≤ 250				—	30	—	60		
X2CrNiMoN18-12-4	4434-317-53-I	^g	—	—	540 to 740	—	—	—	—	yes	yes

Table 5 (continued)

Steel designation		Thickness <i>t</i> or diameter <i>d</i> mm	Proof strength ^a		Tensile strength <i>R_m</i> MPa	Elongation after fracture ^a		Impact energy (ISO-V)		Resistance to intergranular corrosion ^b	
Name	ISO number		<i>R_{p0,2}</i> MPa min.	<i>R_{p1,0}</i> MPa min.		<i>A</i> % min.		<i>KV₂</i> J min.		in the delivery condition	in the sensitized condition ^c
						long.	tr.	long.	tr.		
X2CrNiMoN17-13-5	4439-317-26-E	≤160	280	315	580 to 800	35	—	100	—	yes	yes
		160 < <i>t</i> ≤ 250				—	30	—	60		
X1CrNiMo-CuN20-18-7	4547-312-54-I	≤160	300	340	650 to 850	35	—	100	—	yes	yes
		160 < <i>t</i> ≤ 250				—	30	—	60		
X1CrNiMoN25-22-2	4466-310-50-E	≤160	250	290	540 to 740	35 ^e	—	100	—	yes	yes
		160 < <i>t</i> ≤ 250				—	30	—	60		
X1CrNiMo-CuNW24-22-6	4659-312-66-I	≤160 ^d	420	460	800 to 1 000	50 ^e	—	90	—	yes	yes
X1CrNiMo-CuN24-22-8	4652-326-54-I	≤50 ^d	430	470	750 to 1 050	40 ^e	—	100	—	yes	yes
X2CrNiMn-MoN25-18-6-5	4565-345-65-I	≤160 ^d	420	460	800 to 1 000	35 ^e	—	100	—	yes	yes
Austenitic steels with Ni/Co as main alloying elements											
X1NiCrMoCu25-20-5	4539-089-04-I	≤160	220	260	530 to 730	35 ^e	—	100	—	yes	yes
		160 < <i>t</i> ≤ 250				—	30	—	60		
X1NiCrMo-CuN25-20-7	4529-089-26-I	≤160	300	340	650 to 850	40 ^e	—	100	—	yes	yes
		160 < <i>t</i> ≤ 250				—	35	—	60		
X1NiCrMoCu31-27-4	4563-080-28-I	≤160	220	259	500 to 750	35	—	100	—	yes	yes
		160 < <i>t</i> ≤ 250				—	30	—	60		
<p>NOTE 1 MPa = 1 N/mm².</p> <p>a Elongation and proof strength are not valid for rod.</p> <p>b When tested in accordance with ISO 3651-2.</p> <p>c See note to 7.4.</p> <p>d For larger thicknesses, the values shall be agreed upon.</p> <p>e The minimum elongation value can be lowered to 20 % for sections and bars ≤ 35 mm thickness having a final cold deformation.</p> <p>f Sensitization treatment of 15 min at 700 °C followed by cooling in air.</p> <p>g For rod only.</p> <p>h Maximum HB = 262. This value can be raised by 60 units or the maximum tensile strength value can be raised by 150 MPa and the minimum elongation be lowered to 10 % for sections and bars ≤ 35 mm thickness having undergone final cold deformation.</p>											

Table 6 — Mechanical properties at room temperature for austenitic-ferritic steels in the solution-annealed condition (+AT) (see Table B.1)

Steel designation		Thick-ness <i>t</i> or diame-ter <i>d</i>	Hard-ness ^a HB	0,2 %-proof strength $R_{p0,2}^b$	Tensile strength R_m^b	Elonga-tion after fracture A_{bc}	Impact energy (ISO-V)	Resistance to inter-granular corrosion ^d	
Name	ISO number	mm		MPa min.	MPa min.	% min.	KV ₂ J min.	in the delivery condition	in the sensitized condition ^e
X2CrNiN22-2	4062-322-02-U	≤160 ^f	290	380	650	30	40	yes	yes
X2CrMnNiN21-5-1	4162-321-01-E	≤160 ^f	290	400	650	25	60	yes	yes
X2CrNiN23-4	4362-323-04-I	≤160 ^f	260	400	600	25	100	yes	yes
X2CrNiMoN22-5-3	4462-318-03-I	≤160 ^f	290	450	650	25	100	yes	yes
X2CrNiMnMo-CuN24-4-3-2	4662-824-41-X	≤160 ^f	290	450	650	25	60	yes	yes
X3CrNiMoN27-5-2	4460-312-00-I	≤160 ^f	260	450	620	20	85	yes	yes
X2CrNiMo-CuN25-6-3	4507-325-20-I	≤160 ^f	270	500	700	25	100	yes	yes
X2CrNiMoN25-7-4	4410-327-50-E	≤160 ^f	290	530	730	25	100	yes	yes
X2CrNi-MoCuWN25-7-4	4501-327-60-I	≤160 ^f	290	530	730	25	100	yes	yes
X2CrNiMo-CoN28-8-5-1	4658-327-07-U	≤5 ^f	300	650	800	25	100	yes	yes

NOTE 1 MPa = 1 N/mm².

^a Only for guidance.

^b For rods, only the tensile strength values apply.

^c At the option of the manufacturer, it is permitted to use transverse test specimens provided that the same requirement be met.

^d When tested in accordance with ISO 3651-2.

^e See note to 7.4.

^f For larger thicknesses, the values shall be agreed upon.

Table 7 — Mechanical properties at room temperature for ferritic steels in the annealed condition (+A) (see Table B.1)

Steel designation		Thickness <i>t</i> or diameter <i>d</i> mm	Hardness ^a HB	0,2 %-proof strength <i>R_{p0,2}</i> MPa min.	Tensile strength ^a <i>R_m</i> MPa min.	Elongation after fracture ^{ab} <i>A</i> % min.	Resistance to intergranular corrosion ^c	
Name	ISO number						in the delivery condition	in the welded condition
X6Cr13	4000-410-08-I	25	200	230	400	20	no	no
X6Cr17	4016-430-00-I	75 ^e	200	240	400	20	yes	no
X7CrS17	4004-430-20-I	75 ^d	262	250	430	20	no	no
X3CrNb17	4511-430-71-I	100 ^d	—	230	420	20	yes	yes
X2CrTiNb18	4509-439-40-X	50	200	200	420	28	yes	yes
X6CrMo17-1	4113-434-00-I	e	—	—	440	—	yes	no
X2CrMoTiS18-2	4523-182-35-I	100 ^d	200	280	430	15	yes	no

NOTE 1 MPa = 1 N/mm².

^a The maximum HB values can be raised by 60 units or the maximum tensile strength value can be raised by 150 MPa and the minimum elongation value be lowered to 10 % for sections and bars ≤ 35 mm thickness having undergone final cold deformation.

^b Longitudinal test pieces.

^c When tested in accordance with ISO 3651-2.

^d For larger thicknesses, the values have to be agreed.

^e For rod only.

Table 8 — Mechanical properties at room temperature for martensitic steels in the heat-treated condition (see Table B.1)

Steel designation		Thickness <i>t</i> or diameter <i>d</i> mm	Heat treatment ^a	Hard- ness ^b HB	0,2 %- proof strength <i>R_{p0,2}</i>	Tensile strength <i>R_m</i>		Elongation after fracture <i>A</i>		Impact energy (ISO-V) <i>KV₂</i>	
Name	ISO number					MPa min.	MPa min. MPa max.	% min. (long.)	% min. (tr.)	J min. (long.)	J min. (tr.)
		—	+A	223	—	—	730	—	—	—	—
		≤75 ^c	+QT	—	345	540	—	15	—	25	—
X12CrS13	4005-416-00-I	—	+A	262	—	—	880	—	—	—	—
		≤160 ^c	+QT	—	450	650	—	12	—	—	—
X20Cr13	4021-420-00-I	—	+A	230	—	—	900	—	—	—	—
		≤160 ^c	+QT1	—	500	700	850	13	—	25	—
		≤160 ^c	+QT2	—	600	800	950	12	—	20	—
X30Cr13	4028-420-00-I	—	+A	245	—	—	800	—	—	—	—
		≤75 ^c	+QT	—	540	740	—	12	—	12	—
X17CrNi16-2	4057-431-00-X	—	+A	295	—	—	950	—	—	—	—
		≤160 ^c	+QT1	—	600	800	950	14 ^e	—	20	—
		≤160 ^c	+QT2	—	700	900	1 050	12 ^d	—	15	—
X14CrS17	4019-430-20-I	—	+A	262	—	—	880	—	—	—	—
		≤160 ^c	+QT	—	500	650	850	12 ^d	—	—	—
X110Cr17	4023-440-04-I	≤100 ^c	+A	285	—	—	—	—	—	—	—
X50CrMoV15	4116-420-77-E	—	+A	280	—	—	900	—	—	—	—
X3CrNiMo13-4	4313-415-00-I	—	+A	320	—	—	1 100	—	—	—	—
		≤160 ^c	+QT1	—	520	700	800	15	—	70	—
		160 < <i>t</i> ≤ 250						—	12	—	50
		≤160 ^c	+QT2	—	620	780	980	15	—	70	—
		160 < <i>t</i> ≤ 250						—	12	—	50
		≤160 ^c	+QT3	—	800	900	1 100	12	—	50	—
160 < <i>t</i> ≤ 250	—	10						—	40		
X4CrNiMo16-5-1	4418-431-77-E	—	+A	320	—	—	1100	—	—	—	—
		≤160 ^c	+QT1	—	550	760	960	16	—	90	—
		160 < <i>t</i> ≤ 250						—	14	—	70
		≤160 ^c	+QT2	—	700	900	1100	16	—	80	—
		160 < <i>t</i> ≤ 250						—	14	—	60
X39CrMo17-1	4122-434-09-I	—	+A	280	—	—	900	—	—	—	
		≤160 ^c	+QT	—	550	750	950	12	—	10	—

NOTE 1 MPa = 1 N/mm².

^a +A: soft annealed; +QT: quenched and tempered.

^b The maximum HB values can be raised by 60 units or the maximum tensile strength value can be raised by 150 MPa and the minimum elongation value be lowered to 10 % for sections and bars ≤ 35 mm thickness having undergone final cold deformation.

^c For larger thicknesses, the values shall be agreed upon.

^d *A* = 10 % for thicknesses > 60 mm.

^e *A* = 12 % for thicknesses > 60 mm.

Table 9 — Mechanical properties at room temperature for the precipitation-hardening steel in the heat-treated condition (see Table B.1)

Steel designation		Hardness	Heat treatment ^a	0,2 %-proof strength	Tensile strength	Elongation after fracture	Impact energy (ISO-V)
Name	ISO number	HB		$R_{p0,2}$ MPa min.	R_m MPa	A % min.	KV_2 J min.
X5CrNiCuNb16-4	4542-174-00-I	363	+AT	—	≤1 200	—	—
		—	+P1	725	≥930	16	40
		—	+P2	860	≥1 000	13	—
		—	+P3	1 000	≥1 070	12	—
		—	+P4	1 175	≥1 310	10	—
X7CrNiAl17-7	4568-177-00-I	—	+AT	—	≤50 ^b	—	—

NOTE 1 MPa = 1 N/mm².

^a +AT = solution annealed; +P = precipitation hardened.

^b For rod only.

Table 10 — Minimum values for the 0,2 %- and 1 %-proof strength of austenitic steels at elevated temperatures

Steel designation		Heat treatment condition ^a	Minimum 0,2 %-proof strength _{MPaC}															Minimum 1 %-proof strength _{MPaC}																					
Name	ISO number		at a temperature (in °C) of																																				
		100	150	200	250	300	350	400	450	500	550	100	150	200	250	300	350	400	450	500	550	100	150	200	250	300	350	400	450	500	550								
X10CrNi18-8	4310-301-00-1	+AT	210	200	190	185	180	180	—	—	—	230	215	205	200	195	195	—	—	—	—	—	—	230	215	205	200	195	195	—	—	—	—	—	—				
X2CrNi18-9	4307-304-03-1	+AT	145	130	118	108	100	94	89	85	81	180	160	145	135	127	121	116	112	109	108	—	—	—	—	—	—	—	—	—	—	—	—	—	—	—			
X2CrNi18-9	4311-304-53-1	+AT	205	175	157	145	136	130	125	121	119	118	240	210	187	175	167	160	156	152	149	147	—	—	—	—	—	—	—	—	—	—	—	—	—	—	—		
X5CrNi18-10	4301-304-00-1	+AT	155	140	127	118	110	104	98	95	92	90	190	170	155	145	135	129	125	122	120	120	—	—	—	—	—	—	—	—	—	—	—	—	—	—	—	—	
X6CrNiTi18-10	4541-321-00-1	+AT	175	165	155	145	136	130	125	121	119	118	205	195	185	175	167	161	156	152	149	147	—	—	—	—	—	—	—	—	—	—	—	—	—	—	—	—	
X6CrNiNb18-10	4550-347-00-1	+AT	175	165	155	145	136	130	125	121	119	118	210	195	185	175	167	161	156	152	149	147	—	—	—	—	—	—	—	—	—	—	—	—	—	—	—	—	
X2CrNi19-11	4306-304-03-1	+AT	145	130	118	108	100	94	89	85	81	80	180	160	145	135	127	121	116	112	109	108	—	—	—	—	—	—	—	—	—	—	—	—	—	—	—	—	
X6CrNi18-12	4303-305-00-1	+AT	155	140	127	118	110	104	98	95	92	90	190	170	155	145	135	129	125	122	120	120	—	—	—	—	—	—	—	—	—	—	—	—	—	—	—	—	—
X8CrMnCuNi17-8-3	4597-204-76-1	+AT	225	205	190	177	165	152	145	140	137	135	260	235	218	204	190	180	175	168	165	165	—	—	—	—	—	—	—	—	—	—	—	—	—	—	—	—	
X11CrNiMn19-8-6	4369-202-91-1	+AT	225	200	185	175	165	155	—	—	—	—	255	230	210	200	190	180	—	—	—	—	—	—	—	—	—	—	—	—	—	—	—	—	—	—	—	—	—
X2CrNiMo17-12-2	4404-316-03-1	+AT	165	150	137	127	119	113	108	103	100	98	200	180	165	153	145	139	135	130	128	127	—	—	—	—	—	—	—	—	—	—	—	—	—	—	—	—	—
X5CrNiMo17-12-2	4401-316-00-1	+AT	175	158	145	135	127	120	115	112	110	108	210	190	175	165	155	150	145	141	139	137	—	—	—	—	—	—	—	—	—	—	—	—	—	—	—	—	—
X6CrNiMoTi17-12-2	4571-316-35-1	+AT	185	175	165	155	145	140	135	131	129	127	215	205	192	183	175	169	164	160	158	157	—	—	—	—	—	—	—	—	—	—	—	—	—	—	—	—	—
X2CrNiMo17-12-3	4571-316-35-1	+AT	165	150	137	127	119	113	108	103	100	98	200	180	165	153	145	139	135	130	128	127	—	—	—	—	—	—	—	—	—	—	—	—	—	—	—	—	—
X3CrNiMo17-12-3	4436-316-00-1	+AT	175	158	145	135	127	120	115	112	110	108	210	190	175	165	155	150	145	141	139	137	—	—	—	—	—	—	—	—	—	—	—	—	—	—	—	—	—
X2CrNiMo17-12-3	4429-316-53-1	+AT	215	195	175	165	155	150	145	140	138	136	245	225	205	195	185	180	175	170	168	166	—	—	—	—	—	—	—	—	—	—	—	—	—	—	—	—	—
X2CrNiMo18-14-3	4435-316-91-1	+AT	165	150	137	127	119	113	108	103	100	98	200	180	165	153	145	139	135	130	128	127	—	—	—	—	—	—	—	—	—	—	—	—	—	—	—	—	—
X2CrNiMo17-13-5	4439-317-26-E	+AT	225	200	185	175	165	155	150	—	—	—	255	230	210	200	190	180	175	—	—	—	—	—	—	—	—	—	—	—	—	—	—	—	—	—	—	—	—
X1CrNiMoCuN20-18-7	4547-312-54-1	+AT	230	205	190	180	170	165	160	153	148	—	270	245	225	212	200	195	190	184	180	—	—	—	—	—	—	—	—	—	—	—	—	—	—	—	—	—	—
X1CrNiMoN25-22-2	4466-310-50-E	+AT	195	170	160	150	140	135	—	—	—	—	225	205	190	180	170	165	—	—	—	—	—	—	—	—	—	—	—	—	—	—	—	—	—	—	—	—	—
X1CrNiMoCuN24-22-6	4659-312-66-1	+AT	350	330	315	307	300	298	295	288	280	270	390	365	350	342	335	328	325	318	310	300	—	—	—	—	—	—	—	—	—	—	—	—	—	—	—	—	—
X1CrNiMoCuN24-22-8	4652-326-54-1	+AT	350	320	315	310	300	295	295	285	280	275	390	370	355	345	335	330	320	310	305	—	—	—	—	—	—	—	—	—	—	—	—	—	—	—	—	—	—
X2CrNiMnMoN25-18-6-5	4565-345-65-1	+AT	350	310	270	255	240	225	210	210	210	200	400	355	310	290	270	255	240	240	230	—	—	—	—	—	—	—	—	—	—	—	—	—	—	—	—	—	—
X1NiCrMoCu25-20-5	4539-089-04-1	+AT	205	190	175	160	145	135	125	115	110	105	235	220	205	190	175	165	155	145	140	135	—	—	—	—	—	—	—	—	—	—	—	—	—	—	—	—	—
X1NiCrMoCuN25-20-7	4529-089-26-1	+AT	230	210	190	180	170	165	160	—	—	—	270	245	225	215	205	195	190	—	—	—	—	—	—	—	—	—	—	—	—	—	—	—	—	—	—	—	—
X1NiCrMoCu31-27-4	4563-080-28-1	+AT	190	175	160	155	150	145	135	125	120	115	220	205	190	185	180	175	165	155	150	145	—	—	—	—	—	—	—	—	—	—	—	—	—	—	—	—	—

Table 10 (continued)

Steel designation		Heat treatment condition ^a	Minimum 0,2 %-proof strength MPa ^c										Minimum 1 %-proof strength MPa ^c									
Name	ISO number		at a temperature (in °C) of																			
			100	150	200	250	300	350	400	450	500	550	100	150	200	250	300	350	400	450	500	550

^a +AT = solution annealed.

^b This grade is intended to be used at room temperature in the cold work hardened condition. Therefore, values for proof strength at elevated temperatures are not available. In cases where this grade is used in the solution-annealed condition, the values of grade X5CrNi18-10 (1.4301) can be adopted.

^c 1 MPa = 1 N/mm².

Table 11 — Minimum values for the 0,2 %-proof strength of austenitic-ferritic steels at elevated temperatures

Steel designation		Heat treatment condition ^a	Minimum 0,2 %-proof strength MPa ^b at a temperature (in °C) of			
Name	ISO number		100	150	200	250
X2CrMnNiN21-5-1	4162-321-01-E	+AT	365	325	295	275
X2CrNiN23-4	4362-323-04-I	+AT	330	300	280	265
X2CrNiMoN22-5-3	4462-318-03-I	+AT	360	335	315	300
X2CrNiMnMoCuN24-4-3-2	4662-824-41-X	+AT	385	345	325	315
X3CrNiMoN27-5-2	4460-312-00-I	+AT	360	335	310	295
X2CrNiMoCuN25-6-3	4507-325-20-I	+AT	450	420	400	380
X2CrNiMoN25-7-4	4410-327-50-E	+AT	450	420	400	380
X2CrNiMoCuWN25-7-4	4501-327-60-I	+AT	450	420	400	380

^a +AT = solution annealed.
^b 1 MPa = 1 N/mm².

Table 12 — Minimum values for the 0,2 %-proof strength of ferritic steels at elevated temperatures

Steel designation		Heat treatment condition ^a	Minimum 0,2 %-proof strength MPa ^b at a temperature (in °C) of						
Name	ISO number		100	150	200	250	300	350	400
X6Cr13	4000-410-08-I	+A	220	215	210	205	200	195	190
X6Cr17	4016-430-00-I	+A	220	215	210	205	200	195	190
X3CrNb17	4511-430-71-I	+A	190	180	170	160	155	—	—
X2CrTiNb18	4509-439-40-X	+A	190	180	170	160	155	—	—
X6CrMo17-1	4113-434-00-I	+A	250	240	230	220	210	205	200
X2CrMoTiS18-2	4523-182-35-I	+A	250	240	230	220	210	205	200

^a +A = annealed.
^b 1 MPa = 1 N/mm².

Table 13 — Minimum values for the 0,2 %-proof strength of martensitic steels at elevated temperatures

Steel designation		Heat treatment condition ^a	Minimum 0,2 %-proof strength MPa ^b at a temperature (in °C) of						
Name	ISO number		100	150	200	250	300	350	400
X12Cr13	4006-410-00-I	+QT	420	410	400	385	365	355	305
X20Cr13	4021-420-00-I	+QT1	460	445	430	415	395	365	330
		+QT2	515	495	475	460	440	405	355
X17CrNi16-2	4057-431-00-X	+QT1	515	495	475	460	440	405	355
		+QT2	565	525	505	490	470	430	375
X3CrNiMo13-4	4313-415-00-I	+QT1	500	490	480	470	460	450	—
		+QT2	590	575	560	545	530	515	—
		+QT3	720	690	665	640	620	—	—
X4CrNiMo16-5-1	4418-431-77-E	+QT1	520	510	500	490	480	—	—
		+QT2	660	640	620	600	580	—	—
X39CrMo17-1	4122-434-09-I	+QT	540	535	530	520	510	490	470

^a +QT = quenched and tempered.
^b 1 MPa = 1 N/mm².

Table 14 — Minimum values for the 0,2 %-proof strength of precipitation-hardening steels at elevated temperatures

Steel designation		Heat treatment condition ^a	Minimum 0,2 %-proof strength MPa ^b at a temperature (in °C) of				
Name	ISO number		100	150	200	250	300
X5CrNiCuNb16-4	4542-174-00-I	+P1	680	660	640	620	600
		+P2	730	710	690	670	650
		+P3	880	830	800	770	750

^a +P = precipitation hardened.
^b 1 MPa = 1 N/mm².

Table 15 — Tests to be carried out, test units, and extent of testing in specific testing

Test	^a	Test unit	Product form: rods, bars, and sections	Number of test pieces per sample
Chemical analysis	m	Cast	The cast analysis is given by the manufacturer ^b	
Tensile test at room temperature or hardness test at room temperature	m	Batch ^c	One sample per 25 t; maximum of two per test unit	1
Tensile test at elevated temperature	o		To be agreed at the time of ordering (see Table 10 to 14)	1
Impact test at room temperature	o		To be agreed at the time of ordering	3
Resistance to intergranular corrosion	o ^d		To be agreed at the time of ordering if intergranular corrosion is a hazard	1
<p>^a Tests marked with an “m” (mandatory) shall be carried out as specific tests. In all cases, those marked with an “o” (optional) shall be carried out as specific tests only if agreed at the time of ordering.</p> <p>^b A product analysis can be agreed at the time of ordering; the extent of testing shall be specified at the same time.</p> <p>^c Each batch consists of products coming from the same cast. The products shall have been subjected to the same heat-treatment cycle in the same furnace. In the case of a continuous furnace or in process annealing, a batch is the lot heat treated without interruption with the same process parameters.</p> <p>The shape and size of cross sections of products in a single batch can be different providing that the ratio of the largest to the smallest cross-sectional areas be equal to or less than three.</p> <p>^d The test for resistance to intergranular corrosion is normally not carried out.</p>				

Dimensions in millimetres

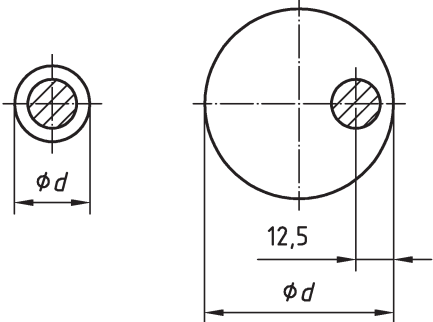
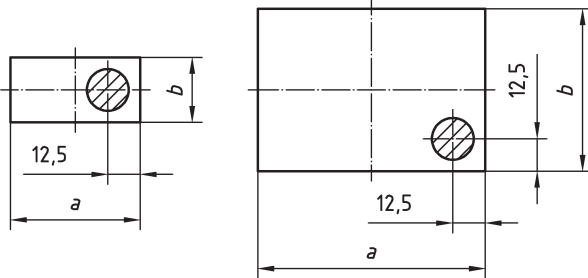
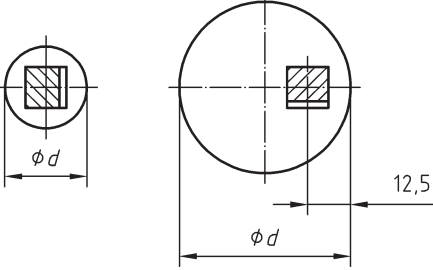
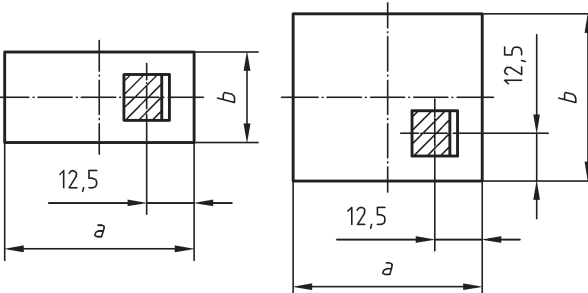
Type of test	Round cross-section products	Rectangular cross-section products
Tensile	$d \leq 25^a$ $25 < d \leq 160$ 	$b \leq 25$ $25 < b \leq 160$ $a \geq b$ $a \geq b$ 
Impact ^b	$15 \leq d \leq 25$ $25 < d \leq 160$ 	$b \leq 25$ $25 < b \leq 160$ $a \geq b$ $a \geq b$ 

^a Samples of product can alternatively be tested unmachined.

^b For products of a round cross section, the axis of the notch is parallel to a diameter; for products with a rectangular cross section, the axis of the notch is perpendicular to the greatest rolled surface.

Figure 1 — Position of test pieces for steel bars and rods ≤ 160 mm diameter or thickness (longitudinal test pieces)

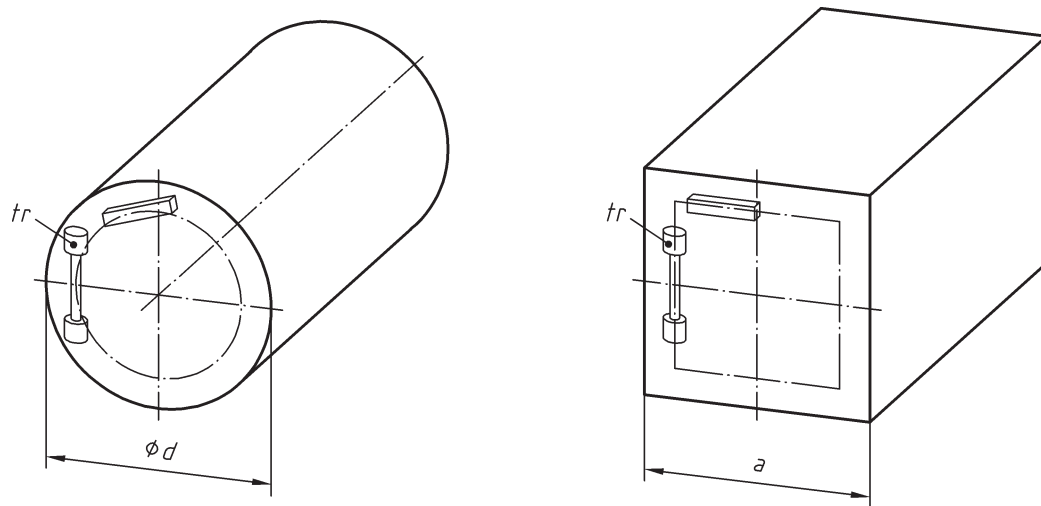

Key

tr transverse

NOTE 1 The axis of the notch on the impact test pieces should be radial in the case of round steel bars, and perpendicular to the nearest rolled surface for rectangular bars.

NOTE 2 The location of the impact test piece is $d/6$ or $a/6$ with max. 50 mm from the surface.

**Figure 2 — Position of test pieces for steel bars > 160 mm diameter or thickness
(transverse test pieces)**

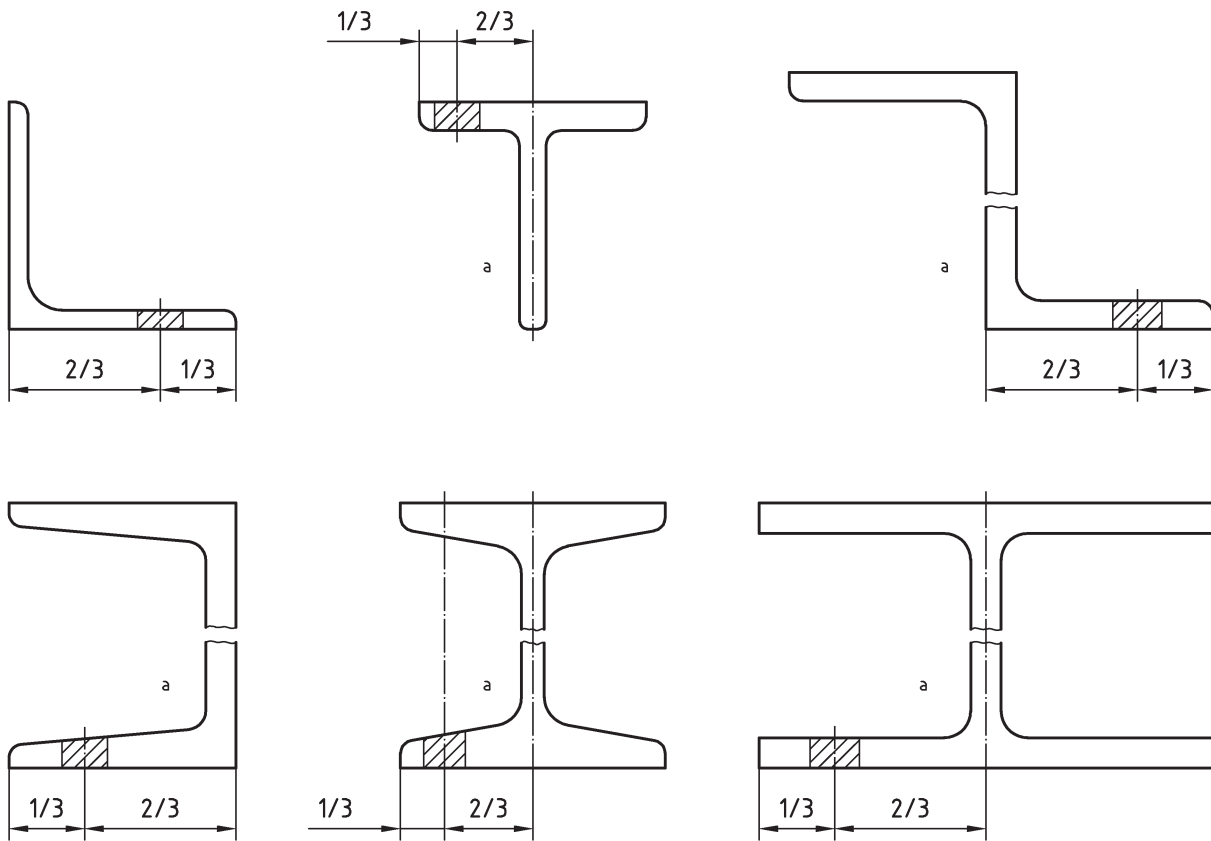

Key

- a By agreement, the sample can be taken from the web, at a quarter of the total height

Figure 3 — Position of test pieces (hatched) for beams, channels, angles, T sections, and Z sections

Annex A (informative)

Guidelines for further treatment (including heat treatment) in fabrication

A.1 The guidelines given in [Tables A.1](#) to [A.5](#) are intended for hot forming and heat treatment.

A.2 Because the corrosion resistance of stainless steels is only ensured when the surface is metallogically clean, layers of scale and annealing colours produced during hot forming, heat treatment, or welding should be removed as far as possible before use. Resistance to corrosion by finished parts made of steels with approximately 13 % Cr is increased by the presence of a smooth, clean surface.

Table A.1 — Guidelines on the temperatures for hot forming and heat treatment^a of austenitic corrosion-resistant stainless steels

Steel designation		Hot forming		Heat treatment symbol	Solution annealing ^b	
Name	ISO number	Temperature °C	Type of cooling		Temperature °C	Type of cooling
X10CrNi18-8	4310-301-00-I	1 200 to 900	Air	+AT	1 000 to 1 100	Water, air ^d
X2CrNi18-9	4307-304-03-I	1 200 to 900				
X10CrNiS18-9	4305-303-00-I	1 200 to 900				
X2CrNiN18-9	4311-304-53-I	1 200 to 900				
X3CrNiCu18-9-4	4567-304-30-I	1 200 to 900				
X6CrNiCuS18-9-2	4570-303-31-I	1 150 to 900				
X5CrNiN19-9	4315-304-51-I	1 150 to 850				
X5CrNi18-10	4301-304-00-I	1 200 to 900				
X6CrNiTi18-10	4541-321-00-I	1 200 to 900				
X6CrNiNb18-10	4550-347-00-I	1 150 to 850				
X2CrNi19-11	4306-304-03-I	1 200 to 900				
X6CrNi18-12	4303-305-00-I	1 200 to 900				
X8CrMnCuN17-8-3	4597-204-76-I	1 150 to 850				
X3CrMnNiCu15-8-5-3	4615-201-75-E	1 200 to 900				
X12CrMnNiN18-9-5	4373-202-00-I	1 150 to 850				
X11CrNiMnN19-8-6	4369-202-91-I	1 150 to 850				
X1CrNi25-21	4335-310-02-I	1 150 to 850				
X2CrNiMo17-12-2	4404-316-03-I	1 200 to 900				
X5CrNiMo17-12-2	4401-316-00-I	1 200 to 900				
X6CrNiMoTi17-12-2	4571-316-35-I	1 200 to 900				
X2CrNiMo17-12-3	4432-316-03-I	1 200 to 900				
X3CrNiMo17-12-3	4436-316-00-I	1 200 to 900				
X2CrNiMoN17-12-3	4429-316-53-I	1 200 to 900				
X2CrNiMo18-14-3	4435-316-91-I	1 200 to 900				
X2CrNiMoN18-12-4	4434-317-53-I	1 150 to 850				
X2CrNiMoN17-13-5	4439-317-26-E	1 200 to 900				
X1CrNiMoCuN20-18-7	4547-312-54-I	1 200 to 1 000				
X1CrNiMoN25-22-2	4466-310-50-E	1 150 to 850				
X1CrNiMoCuNW24-22-6	4659-312-66-I	1 150 to 850				
X1CrNiMoCuN24-22-8	4652-326-54-I	1 200 to 1 000				
X2CrNiMnMoN25-18-6-5	4565-345-65-I	1 200 to 950				
X1NiCrMoCu25-20-5	4539-089-04-I	1 200 to 900				
X1NiCrMoCuN25-20-7	4529-089-26-I	1 200 to 950				
X1NiCrMoCu31-27-4	4563-080-28-I	1 150 to 850				

^a The temperatures of solution annealing shall be agreed upon for simulated heat-treated test pieces.
^b If heat treatment is carried out in a continuous furnace, the upper part of the range specified is usually preferred, or even exceeded.
^c The lower end of the range specified for solution annealing should be aimed at for heat treatment as part of further processing, because otherwise the mechanical properties might be affected. If the temperature of hot forming does not drop below the lower temperature for solution annealing, a temperature of 980 °C is adequate as a lower limit for Mo-free steels; a temperature of 1 000 °C for steels with Mo contents up to 3 %; a temperature of 1 020 °C for steels with Mo contents exceeding 3 %.
^d Rapid cooling.

Table A.2 — Guidelines on the temperatures for hot forming and heat treatment^a of austenitic-ferritic corrosion-resistant stainless steels

Steel designation		Hot forming		Heat treatment symbol	Solution annealing ^b	
Name	ISO number	Temperature °C	Type of cooling		Temperature °C	Type of cooling
X2CrNiN22-2	4062-322-02-U	1 100 to 950	Air	+AT	980 to 1 100	Water, air ^c
X2CrMnNiN21-5-1	4162-321-01-E	1 100 to 900			1 020 to 1 080	Water, air
X2CrNiN23-4	4362-323-04-I	1 200 to 1 000			950 to 1 050	Water, air ^c
X2CrNiMoN22-5-3	4462-318-03-I	1 200 to 950			1 020 to 1 100	Water, air ^c
X2CrNiMnMoCuN24-4-3-2	4662-824-41-X	1 150 to 900			1 000 to 1 150	Water, air
X3CrNiMoN27-5-2	4460-312-00-I	1 200 to 950			1 020 to 1 100	Water, air ^c
X2CrNiMoCuN25-6-3	4507-325-20-I	1 200 to 1 000			1 040 to 1 120	Water
X2CrNiMoN25-7-4	4410-327-50-E	1 200 to 1 000			1 040 to 1 120	Water
X2CrNiMoCuWN25-7-4	4501-327-60-I	1 200 to 1 000			1 040 to 1 120	Water
X2CrNiMoCoN28-8-5-1	4658-327-07-U	1 200 to 1 000			1 050 to 1 150	Water

^a The temperatures of solution annealing shall be agreed upon for simulated heat-treated test pieces.

^b If heat treatment is carried out in a continuous furnace, the upper part of the range specified is usually preferred, or even exceeded.

^c Rapid cooling.

Table A.3 — Guidelines on the temperatures for hot forming and heat treatment^a of ferritic corrosion-resistant stainless steels

Steel designation		Hot forming		Heat treatment symbol	Annealing	
Name	ISO number	Temperature °C	Type of cooling		Temperature ^b °C	Type of cooling
X6Cr13	4000-410-08-I	1 100 to 800	Air	+A	750 to 800	Air
X6Cr17	4016-430-00-I					
X7CrS17	4004-430-20-I					
X3CrNb17	4511-430-71-I					
X2CrTiNb18	4509-439-40-X					
X6CrMo17-1	4113-434-00-I					
X2CrMoTiS18-2	4523-182-35-I				1 000 to 1 050	

^a The temperatures of annealing shall be agreed upon for simulated heat-treated test pieces.

^b If heat treatment is carried out in a continuous furnace, the upper part of the range specified is usually preferred, or even exceeded.

Table A.4 — Guidelines on the temperatures for hot forming and heat treatment^a of martensitic corrosion-resistant stainless steels

Steel designation		Hot forming		Heat treatment symbol	Annealing		Quenching		Tempering
Name	ISO number	Temperature °C	Type of cooling		Temperature ^b °C	Type of cooling	Temperature ^b °C	Type of cooling	Temperature °C
X12Cr13	4006-410-00-I	1 100 to 800	Air	+A	800 to 900	Slow cooling	—	—	—
					Approx. 750	Rapid cooling			
				+QT	—	—	950 to 1 000	Oil, water	700 to 750
X12CrS13	4005-416-00-I	1 100 to 800	Air	+A	745 to 825	Air	—	—	—
				+QT	—	—	950 to 1 000	Oil, air, water	680 to 780
X20Cr13	4021-420-00-I	1 100 to 800	Slow cooling	+A	745 to 825	Air	—	—	—
				+QT1	—	—	950 to 1 050	Oil, air, water	650 to 750
				+QT2	—	—	950 to 1 050	Oil, air, water	600 to 700
X30Cr13	4028-420-00-I	1 100 to 800	Slow cooling	+A	800 to 900	Slow cooling	—	—	—
					Approx. 750	Air cooling			
				+QT	—	—	920 to 980	Oil	600 to 750
X17CrNi16-2	4057-431-00-X	1 100 to 800	Slow cooling	+A	680 to 800	Furnace, air	—	—	—
				+QT1	—	—	950 to 1 050	Oil, air	750 to 800 + 650 to 700 ^c
				+QT2	—	—	950 to 1 050	Oil, air	600 to 650
X14CrS17	4019-430-20-I	1 100 to 800	Air	+A	750 to 850	Furnace, air	—	—	—
				+QT	—	—	950 to 1 070	Oil, air	550 to 650
X110Cr17	4023-440-04-I	1 100 to 900	Slow cooling	+A	780 to 840	Furnace, air	—	—	—
X50CrMoV15	4116-420-77-E	1 100 to 800	Slow cooling	+A	750 to 850	Furnace, air	—	—	—
X3CrNiMo13-4	4313-415-00-I	1 150 to 900	Air	+A	600 to 650	Furnace, air	—	—	—
				+QT1	—	—	950 to 1 050	Oil, air	650 to 700 + 600 to 620
				+QT2	—	—	950 to 1 050	Oil, air	550 to 600
				+QT3	—	—	950 to 1 050	Oil, air	520 to 580
X4CrNiMo16-5-1	4418-431-77-E	1150 to 900	air	+A	600 to 650	Furnace, air	—	—	—
				+QT1	—	—	950 to 1 050	Oil, air	590 to 620 ^d
				+QT2	—	—	950 to 1 050	Oil, air	550 to 620

Table A.4 (continued)

Steel designation		Hot forming		Heat treatment symbol	Annealing		Quenching		Tempering
Name	ISO number	Temperature °C	Type of cooling		Temperature ^b °C	Type of cooling	Temperature ^b °C	Type of cooling	Temperature °C
X39CrMo17-1	4122-434-09-I	1 100 to 800	Slow cooling	+A	750 to 850	Furnace, air	—	—	—
				+QT	—	—	980 to 1 060	Oil	650 to 750
<p>^a The temperatures of annealing, quenching, and tempering shall be agreed upon for simulated heat-treated test pieces.</p> <p>^b If heat treatment is carried out in a continuous furnace, the upper part of the range specified is usually preferred, or even exceeded.</p> <p>^c In cases where the nickel content is on the lower side of the range specified in Table 2, a single tempering at 620 °C to 720 °C can be sufficient.</p> <p>^d Either 2 × 4 h or 1 × 8 h as a minimum time.</p>									

Table A.5 — Guidelines on the temperatures for hot forming and heat treatment^a of precipitation-hardening corrosion-resistant stainless steel

Steel designation		Hot forming		Heat treatment symbol	Solution annealing		Precipitation hardening
Name	ISO number	Temperature °C	Type of cooling		Temperature ^b °C	Type of cooling	Temperature °C
X5CrNiCuNb16-4	4542-174-00-I	1 150 to 900	Furnace, air	+AT ^c	1 020 to 1 060	Rapid cooling	—
				+P1	1 020 to 1 060	Rapid cooling	610 to 630/air
				+P2	1 020 to 1 060		570 to 590/air
				+P3	1 020 to 1 060		540 to 560/air
				+P4	1 020 to 1 060		470 to 490/air
X7CrNiAl17-7	4568-177-00-I	1 150 to 900	Air	+AT	1 060 to 1 080	Water, air	—
<p>^a The temperatures of solution annealing shall be agreed upon for simulated heat-treated test pieces.</p> <p>^b If heat treatment is carried out in a continuous furnace, the upper part of the range specified is usually preferred, or even exceeded.</p> <p>^c Not suitable for direct application; prompt precipitation hardening after solution annealing is recommended to avoid cracking.</p>							

Annex B (informative)

Designations of the steels given in [Table 2](#) and of comparable grades covered in ASTM, EN, JIS, and GB Standards

Table B.1 — Designations of the steels given in [Table 2](#) and of comparable grades covered in ASTM, EN, JIS, and GB Standards

Steel designations according to ^a										
ISO number	ISO name	Line	ASTM A959/ UNS ^b		EN 10088-1:2005 Number ^c		JIS ^d		GB/T20878/ ISC ^e	
				I/N/W ^f		I/N/W ^f		I/N/W ^f		I/N/W ^f
a) Austenitic steels										
4310-301-00-I	X10CrNi18-8	AP26L	S30100	W	1.4310	N	—	—	S30110	W
4307-304-03-I	X2CrNi18-9	AP27B	S30403	W	1.4307	N	SUS304L	W	S30403	W
4305-303-00-I	X10CrNiS18-9	AP27M	S30300	W	1.4305	W	SUS303	W	S30317	W
4311-304-53-I	X2CrNiN18-9	AP27A	S30453	W	1.4311	N	SUS304LN	W	S30453	W
4567-304-30-I	X3CrNiCu18-9-4	AP27F	S30430	W	(1.4567)	N	SUSXM7	W	S30488	W
4570-303-31-I	X6CrNiCuS18-9-2	AP27I	S30331	I	1.4570	N	—	—	—	—
4315-304-51-I	X5CrNiN19-9	AP28F	S30451	N	1.4315	W	SUS304N1 SUS304N2	I N	S30458	W
4301-304-00-I	X5CrNi18-10	AP28E	S30400	W	1.4301	I	SUS304	W	S30408	W
4541-321-00-I	X6CrNiTi18-10	AP28G	S32100	W	1.4541	I	SUS321	W	S32168	W
4550-347-00-I	X6CrNiNb18-10	AP28H	S34700	I	1.4550	N	SUS347	W	S34778	N
4306-304-03-I	X2CrNi19-11	AP30A	S30403	W	1.4306	N	SUS304L	W	S30403	N
4303-305-00-I	X6CrNi18-12	AP30I	S30500	W	1.4303	N	SUS305	W	S30510	W
4597-204-76-I	X8CrMnCuN17-8-3	AP25L	—	—	1.4597	N	—	—	—	—
4615-201-75-E	X3CrMn-NiCu15-8-5-3	AP28C	—	—	(1.4615)	I	—	—	—	—
4373-202-00-I	X12CrMnNiN18-9-5	AP320	S20200	W	1.4373	N	SUS202	W	S35450	N
4369-202-91-I	X11CrNiMnN19-8-6	AP33L	—	—	1.4369	I	—	—	—	—
4335-310-02-I	X1CrNi25-21	AP46A	S31002	W	1.4335	I	—	—	—	—
b) Austenitic steels with Mo										
4404-316-03-I	X2CrNiMo17-12-2	AM31A	S31603	W	1.4404	N	SUS316L	W	S31603	N
4401-316-00-I	X5CrNiMo17-12-2	AM31I	S31600	W	1.4401	N	SUS316	W	S31608	N

Table B.1 (continued)

Steel designations according to ^a										
ISO number	ISO name	Line	ASTM A959/ UNS ^b		EN 10088-1:2005 Number ^c		JIS ^d		GB/T20878/ ISC ^e	
				I/N/W ^f		I/N/W ^f		I/N/W ^f		I/N/W ^f
4571-316-35-I	X6CrNiMoTi17-12-2	AM31F	S31635	W	1.4571	N	SUS316Ti	W	S31668	W
4432-316-03-I	X2CrNiMo17-12-3	AM32A	S31603	W	1.4432	I	SUS316L	W	S31603	W
4436-316-00-I	X3CrNiMo17-12-3	AM32F	S31600	W	1.4436	I	SUS316	W	S31608	W
4429-316-53-I	X2CrNiMoN17-12-3	AM32B	S31653	W	1.4429	N	SUS316LN	W	S31653	N
4435-316-91-I	X2CrNiMo18-14-3	AM35A	—	—	1.4435	N	SUS316L	W	S31603	W
4434-317-53-I	X2CrNiMoN18-12-4	AM34B	S31753	W	1.4434	N	SUS317LN	W	S31753	W
4439-317-26-E	X2CrNiMoN17-13-5	AM35B	S31726	N	1.4439	I	—	—	S31723	W
4547-312-54-I	X1CrNiMo-CuN20-18-7	AM45A	S31254	W	1.4547	N	SUS312L	W	S31252	N
4466-310-50-E	X1CrNiMoN25-22-2	AM49A	S31050	W	1.4466	I	—	—	S31053	W
4659-312-66-I	X1CrNiMo-CuNW24-22-6	AM52B	S31266	W	1.4659	I	—	—	—	—
4652-326-54-I	X1CrNiMo-CuN24-22-8	AM54A	S32654	N	1.4652	I	—	—	S32652	N
4565-345-65-I	X2CrNiMn-MoN25-18-6-5	AM54B	S34565	W	1.4565	I	—	—	S34553	N
c) Austenitic steels with Ni/Co as main alloying elements										
4539-089-04-I	X1NiCrMoCu25-20-5	AN50A	N08904	W	1.4539	N	SUS890L	W	S39042	N
4529-089-26-I	X1NiCrMo-CuN25-20-7	AN52A	N08926	W	1.4529	N	—	—	—	—
4563-080-28-I	X1NiCrMoCu31-27-4	AN62A	N08028	W	1.4563	I	—	—	—	—
d) Austenitic-ferritic (duplex) steels										
4062-322-02-U	X2CrNiN22-2	DP24A	S32202	N	1.4062	I	—	—	—	—
4162-321-01-E	X2CrMnNiN21-5-1	DP27F	S32101	N	1.4162	I	—	—	—	—
4362-323-04-I	X2CrNiN23-4	DP27B	S32304	W	1.4362	I	—	—	S23043	W
4462-318-03-I	X2CrNiMoN22-5-3	DM30A	S32205	N	1.4462	I	SUS329J3L	W	S22053	N
4462-824-41-X	X2CrNiMnMo-CuN24-4-3-2	DM33A	—	—	1.4462	I	—	—	—	—
4460-312-00-I	X3CrNiMoN27-5-2	DM34F	S31200	W	1.4460	I	—	—	S22553	W
4507-325-20-I	X2CrNiMo-CuN25-6-3	DM34A	S32520	W	1.4507	I	—	—	S25554	—
4410-327-50-E	X2CrNiMoN25-7-4	DM36A	S32750	W	1.4410	I	—	—	S25073	W
4501-327-60-I	X2CrNi-MoCuWN25-7-4	DM36B	S32760	I	1.4501	N	—	—	S27603	N
4658-327-07-U	X2CrNiMo-CoN28-8-5-1	DM42A	S32707	I	1.4658	I	—	—	—	—
e) Ferritic steels										

Table B.1 (continued)

Steel designations according to ^a										
ISO number	ISO name	Line	ASTM A959/ UNS ^b		EN 10088-1:2005 Number ^c		JIS ^d		GB/T20878/ ISC ^e	
				I/N/W ^f		I/N/W ^f		I/N/W ^f		I/N/W ^f
4000-410-08-I	X6Cr13	FP13G	S41008	W	1.4000	N	SUS410S	N	S41008	N
4016-430-00-I	X6Cr17	FP17I	S43000	W	1.4016	I	SUS430	W	S11710	W
4004-430-20-I	X7CrS17	FP17L	S43020	W	(1.4004)	I	SUS430F	W	S11717	W
4511-430-71-I	X3CrNb17	FP17G	—	—	1.4511	N	SUS430LX	W	—	—
4509-439-40-X	X2CrTiNb18	FP18B	S43940	I	1.4509	N	SUS430LX	W	S11873	I
4113-434-00-I	X6CrMo17-1	FM18I	S43400	W	1.4113	N	SUS434	W	S11790	W
4523-182-35-I	X2CrMoTiS18-2	FM20C	S18235	W	1.4523	I	—	—	—	—
f) Martensitic steels										
4006-410-00-I	X12Cr13	MP13B	S41000	W	1.4006	I	SUS410	W	S41010	W
4005-416-00-I	X12CrS13	MP13C	S41600	W	1.4005	N	SUS416	W	S41617	N
4021-420-00-I	X20Cr13	MP13I	S42000	W	1.4021	I	SUS420J1	N	S42020	N
4028-420-00-I	X30Cr13	MP13M	S42000	W	1.4028	I	SUS420J2	W	S42030	N
4057-431-00-X	X17CrNi16-2	MP16G	S43100	W	1.4057	I	SUS431	W	S43120	I
4019-430-20-I	X14CrS17	MP17F	S43020	W	(1.4019)	I	—	—	S11717	W
4023-440-04-I	X110Cr17	MP17W	S44004	W	(1.4023)	I	SUS440C	N	S44096	N
4313-415-00-I	X3CrNiMo13-4	MM14A	S41500	W	1.4313	N	SUSF6NM	W	S41595	W
4116-420-77-E	X50CrMoV15	MM15U	—	—	1.4116	I	—	—	—	—
4122-434-09-I	X39CrMo17-1	MM18R	—	—	1.4122	I	—	—	—	—
g) Precipitation-hardening steels										
4542-174-00-I	X5CrNiCuNb16-4	PP20I	S17400	W	1.4542	N	SUS630	W	S51740	W
4568-177-00-I	X7CrNiAl17-7	PP24L	S17700	N	1.4568	N	SUS631	W	S51770	N
NOTE The grades given in this table are comparable to those given in Table 2 . However, to compare similar grades, it is necessary to check each element before making a substitution.										
a See the sources in the Bibliography.										
b US steel listed in ASTM A959 and in UNS; if the steel number is given in brackets, then the steel has only a UNS number.										
c European steel listed in EN 10088-1:2005 and in the “Stahl-Eisen-Liste”; if the steel number is given in brackets, then the steel is only listed in the “Stahl-Eisen-Liste”.										
d Japanese Industrial Standard.										
e Chinese steel of ISC number listed in GB/T20878.										
f I = identical steel to ISO steel grade; N = steel grade with closer match of composition, but not identical; W = wider match.										

Annex C (informative)

Applicable dimensional standards

ISO 286-1, title/subject: Geometrical product specifications (GPS) — ISO code system for tolerances on linear sizes — Part 1: Basis of tolerances, deviations and fits

NOTE The notes in [Table 4](#) contain information concerning tolerances for bright bars; special agreements are necessary if such information should become obligatory.

ISO 1035-1, title/subject: Hot-rolled steel bars — Part 1: Dimensions of round bars

ISO 1035-2, title/subject: Hot-rolled steel bars — Part 2: Dimensions of square bars

ISO 1035-3, title/subject: Hot-rolled steel bars — Part 3: Dimensions of flat bars

ISO 1035-4, title/subject: Hot-rolled steel bars — Part 4: Tolerances

ISO 16124, title/subject: Steel wire rod — Dimensions and tolerances

ASTM A 484M-03, title/subject: Standard Specification for General Requirements for Stainless Steel Bars, Billets, and Forgings

ASTM A 555M-97:2002, title/subject: Standard Specification for General Requirements for Stainless Steel Wire and Wire Rods

EN 10017, title/subject: Steel rod for drawing and/or cold rolling — Dimensions and tolerances

EN 10024¹⁾, title/subject: Hot rolled taper flange I sections — Tolerances on shape and dimensions

EN 10034¹⁾, title/subject: Structural steel I and H sections — Tolerances on shape and dimensions

EN 10055¹⁾, title/subject: Hot rolled steel equal flange tees with radiused root and toes — Dimensions and tolerances on shape and dimensions

EN 10056-2¹⁾, title/subject: Structural steel equal and unequal leg angles — Part 2: Tolerances on shape and dimensions

EN 10058, title/subject: Hot rolled flat steel bars for general purposes — Dimensions and tolerances on shape and dimensions

EN 10059, title/subject: Hot rolled square steel bars for general purposes — Dimensions and tolerances on shape and dimensions

EN 10060, title/subject: Hot rolled round steel bars — Dimensions and tolerances on shape and dimensions

EN 10061, title/subject: Hot rolled hexagon steel bars — Dimensions and tolerances on shape and dimensions

EN 10279¹⁾, title/subject: Hot rolled steel channels — Tolerances on shape, dimensions and mass

1) In the scopes of these dimensional standards, stainless steels are expressly excluded. On the other hand, these standards are used in practice for stainless steels, too. Therefore, they are listed here.

Bibliography

- [1] ISO 4954, *Steels for cold heading and cold extruding*
- [2] ISO 4955, *Heat-resistant steels*
- [3] ISO 6931-1, *Stainless steels for springs — Part 1: Wire*
- [4] ISO 286-1, *Geometrical product specifications (GPS) — ISO code system for tolerances on linear sizes — Part 1: Basis of tolerances, deviations and fits*
- [5] ISO 1035-1, *Hot-rolled steel bars — Part 1: Dimensions of round bars*
- [6] ISO 1035-2, *Hot-rolled steel bars — Part 2: Dimensions of square bars*
- [7] ISO 1035-3, *Hot-rolled steel bars — Part 3: Dimensions of flat bars*
- [8] ISO 1035-4, *Hot-rolled steel bars — Part 4: Tolerances*
- [9] ISO 16124, *Steel wire rod — Dimensions and tolerances*
- [10] ASTM A 484M-03, *Standard Specification for General Requirements for Stainless Steel Bars, Billets, and Forgings*
- [11] ASTM A 555M-97:2002, *Standard Specification for General Requirements for Stainless Steel Wire and Wire Rods*
- [12] EN 10017, *Steel rod for drawing and/or cold rolling — Dimensions and tolerances*
- [13] EN 10024, *Hot rolled taper flange I sections — Tolerances on shape and dimensions*
- [14] EN 10034, *Structural steel I and H sections — Tolerances on shape and dimensions*
- [15] EN 10055, *Hot rolled steel equal flange tees with radiused root and toes — Dimensions and tolerances on shape and dimensions*
- [16] EN 10056-2, *Structural steel equal and unequal leg angles — Part 2: Tolerances on shape and dimensions*
- [17] EN 10058, *Hot rolled flat steel bars for general purposes — Dimensions and tolerances on shape and dimensions*
- [18] EN 10059, *Hot rolled square steel bars for general purposes — Dimensions and tolerances on shape and dimensions*
- [19] EN 10060, *Hot rolled round steel bars — Dimensions and tolerances on shape and dimensions*
- [20] EN 10061, *Hot rolled hexagon steel bars — Dimensions and tolerances on shape and dimensions*
- [21] EN 10279²⁾, *Hot rolled steel channels — Tolerances on shape, dimensions and mass*

2) In the scopes of these dimensional standards, stainless steels are expressly excluded. On the other hand, these standards are used in practice for stainless steels, too. Therefore, they are listed here.

British Standards Institution (BSI)

BSI is the national body responsible for preparing British Standards and other standards-related publications, information and services.

BSI is incorporated by Royal Charter. British Standards and other standardization products are published by BSI Standards Limited.

About us

We bring together business, industry, government, consumers, innovators and others to shape their combined experience and expertise into standards-based solutions.

The knowledge embodied in our standards has been carefully assembled in a dependable format and refined through our open consultation process. Organizations of all sizes and across all sectors choose standards to help them achieve their goals.

Information on standards

We can provide you with the knowledge that your organization needs to succeed. Find out more about British Standards by visiting our website at bsigroup.com/standards or contacting our Customer Services team or Knowledge Centre.

Buying standards

You can buy and download PDF versions of BSI publications, including British and adopted European and international standards, through our website at bsigroup.com/shop, where hard copies can also be purchased.

If you need international and foreign standards from other Standards Development Organizations, hard copies can be ordered from our Customer Services team.

Subscriptions

Our range of subscription services are designed to make using standards easier for you. For further information on our subscription products go to bsigroup.com/subscriptions.

With **British Standards Online (BSOL)** you'll have instant access to over 55,000 British and adopted European and international standards from your desktop. It's available 24/7 and is refreshed daily so you'll always be up to date.

You can keep in touch with standards developments and receive substantial discounts on the purchase price of standards, both in single copy and subscription format, by becoming a **BSI Subscribing Member**.

PLUS is an updating service exclusive to BSI Subscribing Members. You will automatically receive the latest hard copy of your standards when they're revised or replaced.

To find out more about becoming a BSI Subscribing Member and the benefits of membership, please visit bsigroup.com/shop.

With a **Multi-User Network Licence (MUNL)** you are able to host standards publications on your intranet. Licences can cover as few or as many users as you wish. With updates supplied as soon as they're available, you can be sure your documentation is current. For further information, email bsmusales@bsigroup.com.

BSI Group Headquarters

389 Chiswick High Road London W4 4AL UK

Revisions

Our British Standards and other publications are updated by amendment or revision.

We continually improve the quality of our products and services to benefit your business. If you find an inaccuracy or ambiguity within a British Standard or other BSI publication please inform the Knowledge Centre.

Copyright

All the data, software and documentation set out in all British Standards and other BSI publications are the property of and copyrighted by BSI, or some person or entity that owns copyright in the information used (such as the international standardization bodies) and has formally licensed such information to BSI for commercial publication and use. Except as permitted under the Copyright, Designs and Patents Act 1988 no extract may be reproduced, stored in a retrieval system or transmitted in any form or by any means – electronic, photocopying, recording or otherwise – without prior written permission from BSI. Details and advice can be obtained from the Copyright & Licensing Department.

Useful Contacts:

Customer Services

Tel: +44 845 086 9001

Email (orders): orders@bsigroup.com

Email (enquiries): cservices@bsigroup.com

Subscriptions

Tel: +44 845 086 9001

Email: subscriptions@bsigroup.com

Knowledge Centre

Tel: +44 20 8996 7004

Email: knowledgecentre@bsigroup.com

Copyright & Licensing

Tel: +44 20 8996 7070

Email: copyright@bsigroup.com



...making excellence a habit.™