

Methods for the calibration of vibration and shock transducers

Part 31: Testing of transverse vibration sensitivity

ICS 17.160

National foreword

This British Standard is the UK implementation of ISO 16063-31:2009. It supersedes BS 6955-11:1994 which is withdrawn.

The UK participation in its preparation was entrusted to Technical Committee GME/21/2, Vibration and shock measuring instruments and testing equipment.

A list of organizations represented on this committee can be obtained on request to its secretary.

This publication does not purport to include all the necessary provisions of a contract. Users are responsible for its correct application.

Compliance with a British Standard cannot confer immunity from legal obligations.

This British Standard was published under the authority of the Standards Policy and Strategy Committee on 30 November 2009

© BSI 2009

ISBN 978 0 580 63215 0

Amendments/corrigenda issued since publication

Date	Comments

INTERNATIONAL STANDARD

ISO
16063-31

First edition
2009-08-15

Methods for the calibration of vibration and shock transducers —

Part 31: Testing of transverse vibration sensitivity

*Méthodes pour l'étalonnage des transducteurs de vibrations et de
chocs —*

Partie 31: Essai de sensibilité aux vibrations transversales



Reference number
ISO 16063-31:2009(E)

© ISO 2009

PDF disclaimer

This PDF file may contain embedded typefaces. In accordance with Adobe's licensing policy, this file may be printed or viewed but shall not be edited unless the typefaces which are embedded are licensed to and installed on the computer performing the editing. In downloading this file, parties accept therein the responsibility of not infringing Adobe's licensing policy. The ISO Central Secretariat accepts no liability in this area.

Adobe is a trademark of Adobe Systems Incorporated.

Details of the software products used to create this PDF file can be found in the General Info relative to the file; the PDF-creation parameters were optimized for printing. Every care has been taken to ensure that the file is suitable for use by ISO member bodies. In the unlikely event that a problem relating to it is found, please inform the Central Secretariat at the address given below.



COPYRIGHT PROTECTED DOCUMENT

© ISO 2009

All rights reserved. Unless otherwise specified, no part of this publication may be reproduced or utilized in any form or by any means, electronic or mechanical, including photocopying and microfilm, without permission in writing from either ISO at the address below or ISO's member body in the country of the requester.

ISO copyright office
Case postale 56 • CH-1211 Geneva 20
Tel. + 41 22 749 01 11
Fax + 41 22 749 09 47
E-mail copyright@iso.org
Web www.iso.org

Published in Switzerland

Contents

Page

Foreword	iv
1 Scope	1
2 Normative references	1
3 Uncertainty considerations	2
4 Determination of transverse sensitivity using a single-axis vibration generator.....	2
4.1 Apparatus	2
4.2 Method	2
4.2.1 Test procedure.....	2
4.2.2 Expression of results	3
5 Determination of the transverse sensitivity using a vibration generator with turntable	4
5.1 Apparatus	4
5.2 Method	6
5.3 Expression of results	6
6 Determination of transverse sensitivity using a test system with <i>X</i>- and <i>Y</i>-vibration generators	6
6.1 Apparatus	6
6.2 Method and expression of results	9
7 Determination of the transverse sensitivity using a tri-axial vibration generator	11
7.1 Apparatus	11
7.2 Method and expression of results	14
8 Equipment for measuring of the input and output signals of the transducer to be tested	15
9 Preferred amplitudes and frequencies	15
Annex A (normative) Definition of transverse sensitivity.....	16
Bibliography.....	18

Foreword

ISO (the International Organization for Standardization) is a worldwide federation of national standards bodies (ISO member bodies). The work of preparing International Standards is normally carried out through ISO technical committees. Each member body interested in a subject for which a technical committee has been established has the right to be represented on that committee. International organizations, governmental and non-governmental, in liaison with ISO, also take part in the work. ISO collaborates closely with the International Electrotechnical Commission (IEC) on all matters of electrotechnical standardization.

International Standards are drafted in accordance with the rules given in the ISO/IEC Directives, Part 2.

The main task of technical committees is to prepare International Standards. Draft International Standards adopted by the technical committees are circulated to the member bodies for voting. Publication as an International Standard requires approval by at least 75 % of the member bodies casting a vote.

Attention is drawn to the possibility that some of the elements of this document may be the subject of patent rights. ISO shall not be held responsible for identifying any or all such patent rights.

ISO 16063-31 was prepared by Technical Committee ISO/TC 108, *Mechanical vibration, shock and condition monitoring*, Subcommittee SC 3, *Use and calibration of vibration and shock measuring instruments*.

This first edition cancels and replaces ISO 5347-11:1993.

ISO 16063 consists of the following parts, under the general title *Methods for the calibration of vibration and shock transducers*:

- *Part 1: Basic concepts*
- *Part 11: Primary vibration calibration by laser interferometry*
- *Part 12: Primary vibration calibration by the reciprocity method*
- *Part 13: Primary shock calibration using laser interferometry*
- *Part 15: Primary angular vibration calibration by laser interferometry*
- *Part 21: Vibration calibration by comparison to a reference transducer*
- *Part 22: Shock calibration by comparison to a reference transducer*
- *Part 31: Testing of transverse vibration sensitivity*
- *Part 41: Calibration of laser vibrometers*

The following parts are planned:

- Part 23: Angular vibration calibration by comparison to reference transducers
- Part 32: Resonance testing¹⁾
- Part 42: Calibration of seismometers

1) Revision of ISO 5347-14:1993 and ISO 5347-22:1997.

Methods for the calibration of vibration and shock transducers —

Part 31: Testing of transverse vibration sensitivity

1 Scope

This part of ISO 16063 specifies details of the instrumentation and methods to be used for transverse vibration sensitivity testing. It applies to rectilinear velocity and acceleration transducers.

The methods and procedures specified in this part of ISO 16063 allow the determination of the sensitivity of a transducer to vibration in the plane perpendicular to its geometric axis of sensitivity (see Annex A). Because the magnitude of this transverse sensitivity can vary with the direction of the applied vibration, the various methods determine the maximum value. Using that value, the ratio of the transverse sensitivity to the sensitivity on the geometric axis of the transducer can be calculated. In addition, the angle at which the maximum transverse sensitivity occurs can be determined.

The methods and techniques specified can be applied without re-mounting the transducer away from its mounting surface during the test, thus avoiding significant uncertainties often encountered in methods which require repeated mounting. The different methods specified use a single-axis vibration exciter, a two-axis vibration exciter or a tri-axial vibration exciter. Tri-axial vibration excitation allows the transverse sensitivity and the sensitivity on the geometric axis to be determined simultaneously, thus simulating application conditions where the transducer is exposed to multi-axial vibration.

NOTE In accelerometer designs using a bending beam, the transverse sensitivity measured without any vibration acting on the geometric axis of sensitivity of the accelerometer may considerably differ from the transverse sensitivity measured in the presence of a vibration acting on the geometric axis of sensitivity (i.e. when the bending beam is deflected by a vibration to be measured).

This part of ISO 16063 is applicable to a frequency range from 1 Hz to 5 kHz and for a dynamic range from 1 m/s² to 1 000 m/s² (frequency dependent) and from 1 mm/s to 1 m/s (frequency dependent). Although among all the systems specified it is possible to achieve these ranges, generally each has limitations permitting its use in much smaller ranges.

The methods specified are by comparison both to a reference transducer and to a laser interferometer.

The methods specified allow an expanded uncertainty of the transverse sensitivity (coverage factor $k = 2$) of 0,1 % or less to be achieved, if the expanded uncertainty is expressed as a percentage of the sensitivity of the test transducer in its sensitive axis.

2 Normative references

The following referenced documents are indispensable for the application of this document. For dated references, only the edition cited applies. For undated references, the latest edition of the referenced document (including any amendments) applies.

ISO 266, *Acoustics — Preferred frequencies*

ISO 16063-1:1998, *Methods for the calibration of vibration and shock transducers: Part 1: Basic concepts*

3 Uncertainty considerations

An expanded uncertainty of 0,1 % (see Clause 1) means, for the example of a transverse sensitivity of 1 %, that the measured value lies within the interval of 0,9 % to 1,1 %.

All users of this part of ISO 16063 are expected to assess and report the uncertainty of measurement according to ISO 16063-1:1998, Annex A, to document their uncertainty expressed as expanded uncertainties for a coverage factor of 2 or a coverage probability of 95 %. It is the responsibility of the laboratory or end user to make sure that the reported values of expanded uncertainty are credible.

4 Determination of transverse sensitivity using a single-axis vibration generator

4.1 Apparatus

The single-axis test system of transverse sensitivity specified in this clause consists of a single-axis vibration exciter that is equipped with a specially designed fixture that enables the transducer under test to be mounted such that its geometric axis of sensitivity is perpendicular to the direction of motion of the vibration exciter table (where the direction of the motion of the vibration exciter table shown in Figure 1 is defined as the *Z*-direction). It shall be possible to mount the test transducer at different angles about its sensitive axis, preferably for continuous rotation over at least 180°. An example (Reference [5]) of an octahedral fixture is shown in Figure 1.

Another example is the use of an electro-dynamic long-stroke vibration exciter operated in combination with a turntable driven by a stepper motor as specified in Clause 5. The amplitude of the transverse acceleration of the fixture due to transverse motion inherent in the vibration exciter shall be less than 1 % of the acceleration amplitude in the *Z*-direction at each of the test frequencies. For cases in which the measured transverse sensitivity is less than 2 % of the sensitivity measured on the geometric axis, the transverse motion of the vibration exciter shall meet even higher requirements (e.g. 0,2 % at the test frequencies). To ensure that the transverse motion of the vibration exciter is sufficiently small, measurements of the transverse motion of the total setup (vibration exciter with fixture) with a load close in shape and weight to the transducer being tested should be performed beforehand or the transverse motion could be monitored during the measurement of the transverse sensitivity. For the measurement of the input and output signal of the transducer to be tested, see Clause 8.

The frequency range of the transverse test system is generally 1 Hz to 5 kHz, depending on the working range of the vibration exciter, and on the mass of the fixtures and of the transducer tested. Acceleration amplitudes from 1 m/s² to 200 m/s² can be generated.

4.2 Method

4.2.1 Test procedure

Vibrate the transducer at the reference amplitude and frequency on the geometric axis of sensitivity to determine its sensitivity, S_N (briefly referred to as S). Determine the values of transverse sensitivity as a function of frequency, S_T , by vibrating perpendicularly to the sensitive axis of the transducer at different angles about its sensitive axis.

The directions and magnitudes of the maximum and minimum transverse sensitivity shall be reported at a designated test frequency or as a function of frequency.

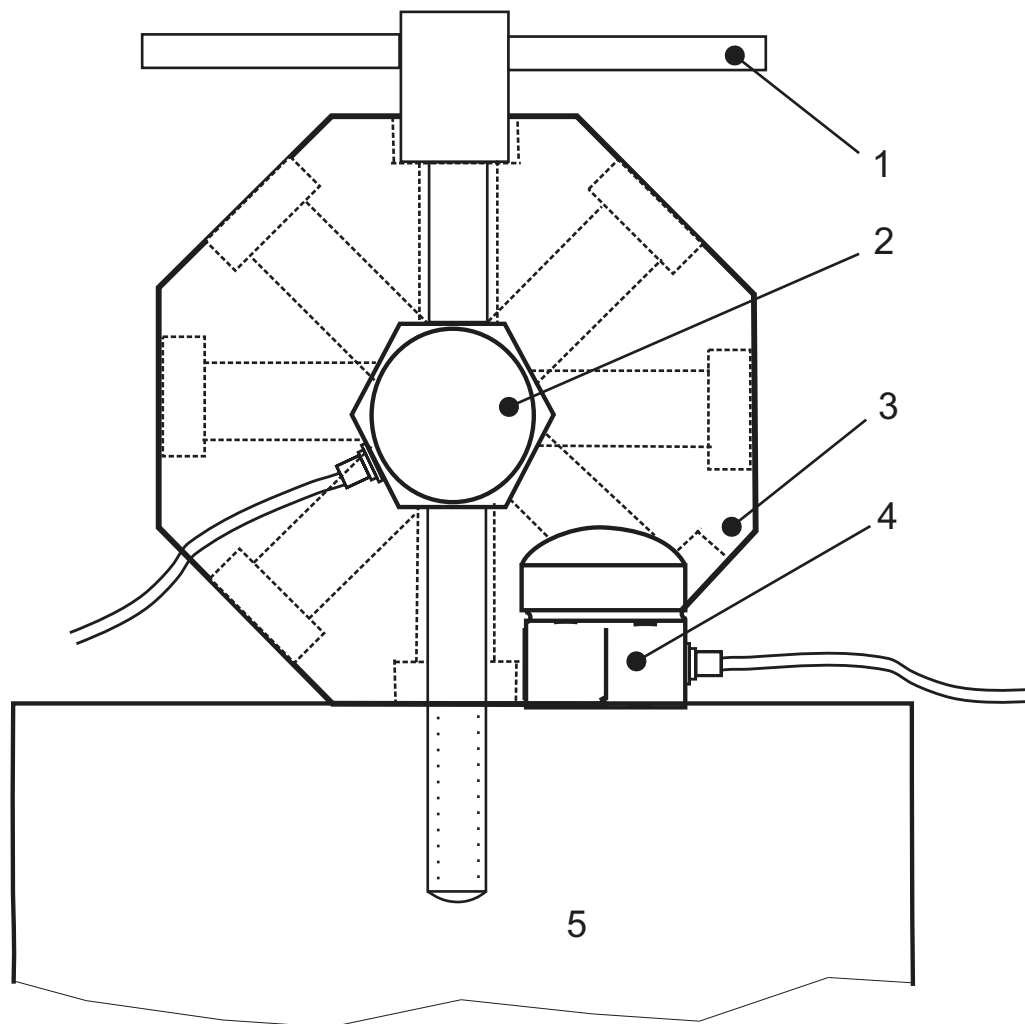

Key

- 1 screw unit for re-mounting the octahedron in different positions (angle shifts of 45°)
- 2 transducer to be tested
- 3 octahedron
- 4 reference accelerometer
- 5 vibration exciter table

Figure 1 — Example of a fixture for mounting the test transducer with its sensitive axis perpendicular to the direction of the vibration generated by the vibration exciter

4.2.2 Expression of results

Calculate the transverse sensitivity, S_T , using Equation (1):

$$S_T = \frac{\hat{u}_{out}}{\hat{a}_T} \quad (1)$$

where

\hat{u}_{out} is the amplitude of the output signal of the transducer vibrating perpendicularly to its sensitive axis;

\hat{a}_T is the amplitude of the acceleration in the test direction.

Calculate the relative transverse sensitivity, S_T^* , expressed as a percentage, using Equation (2):

$$S_T^* = \frac{S_T}{S} \times 100 \% \quad (2)$$

where S is the sensitivity of the transducer on the geometric axis of sensitivity.

5 Determination of the transverse sensitivity using a vibration generator with turntable

5.1 Apparatus

5.1.1 General. The single-axis test system of transverse sensitivity specified in this clause consists of a single-axis vibration exciter and a rotating table.

NOTE An apparatus similar to Figure 2 is used by several manufacturers of accelerometers in order to comply with criteria contained in ISA-RP 37.2^[6]. For details of the apparatus specified as an example in the following, see Reference [7].

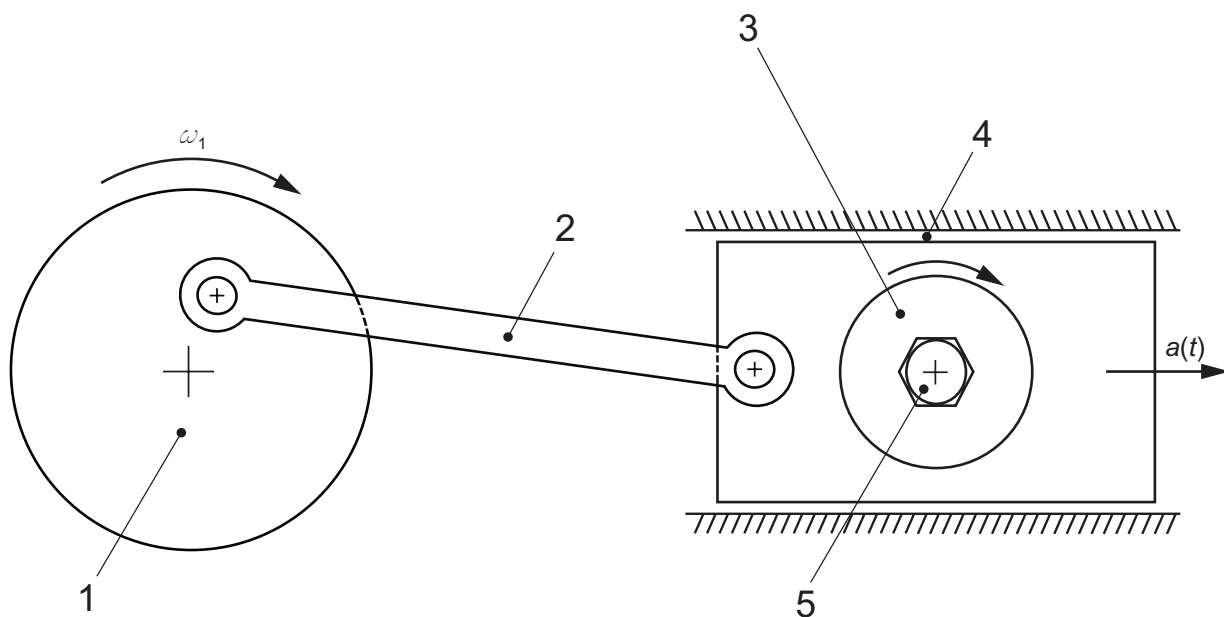

Key

- 1 rotating disk
- 2 drive rod
- 3 turntable controlled by a stepper motor
- 4 slide or air bearing
- 5 transducer to be tested
- $a(t)$ acceleration
- ω_1 angular frequency ("speed")

Figure 2 — Example of a mechanical vibration exciter with turntable used for the measurement of the transverse sensitivity

The crank is driven at a constant speed, ω_1 , by an electric motor via a toothed belt. The slider, in turn, drives a carriage, the motion of which is constrained by two bars with bronze sockets. On the carriage, there is a turntable whose motion is controlled by a stepper motor. The carriage is made to oscillate at approximately

12 Hz with a 25,4 mm peak-to-peak amplitude, which corresponds to a root mean square (r.m.s.) acceleration value of 51 m/s².

The accelerometer to be tested is held in place on the turntable of the carriage through, for instance, a ¼-28 UNF hole drilled in the centre of the turntable. Normally the accelerometer is placed such that the geometric axis is perpendicular to the direction of acceleration. However, by using specially designed adaptors, the geometric axis of the accelerometer can be aligned with the direction of motion of the carriage. Then, the sensitivity on the geometric axis of the accelerometer can be determined at the same excitation frequency as its transverse sensitivity. The accelerometer then can be mounted with its geometric axis perpendicular to the direction of motion of the carriage to determine transverse sensitivity as a function of the orientation angle, as illustrated in Figure 3. The time to complete one revolution can be between 30 s and 120 s, depending on the resolution, especially for the direction of least cross-axis sensitivity.

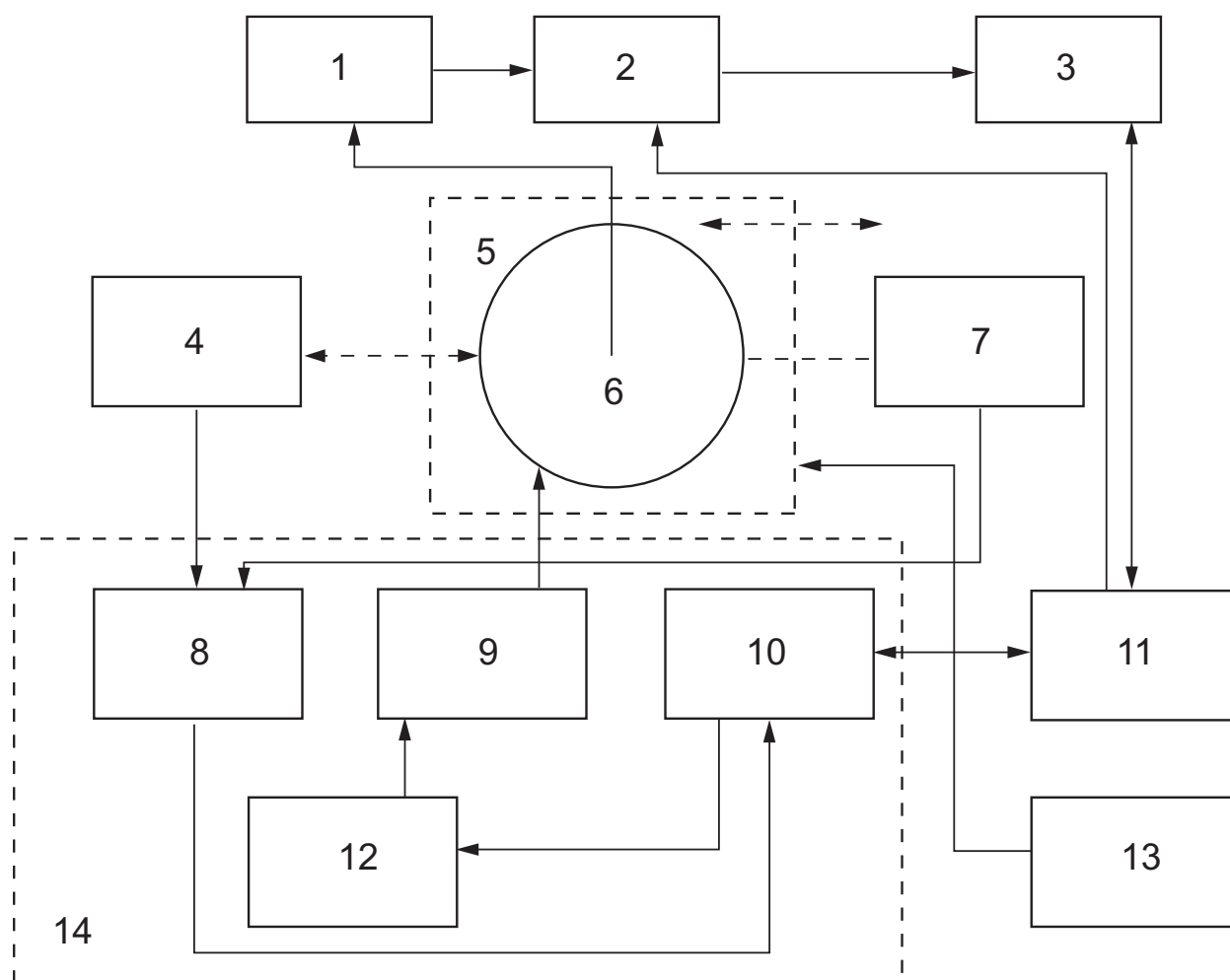

Key

- | | |
|--|---|
| 1 power supply/coupler (or) charge amplifier | 8 angular position controller for items 4 and 7 |
| 2 filter | 9 stepper motor |
| 3 digital voltmeter (DVM) | 10 controller |
| 4 angular position detector part A | 11 computer |
| 5 carriage | 12 driver |
| 6 transducer under test mounted on turntable | 13 a.c. motor |
| 7 angular position detector part B | 14 turntable control panel |

Figure 3 — Example of block diagram of complete signal conditioning and data acquisition system

It is recommended that an accelerometer be permanently or periodically placed in the direction of the slider motion to monitor the condition of the exciter. By double integration, the value of amplitude of displacement can be computed from the acceleration experienced in the excitation axis and hence a comparison drawn between the observed value and the expected value (25,4 mm).

The transverse test system is generally operated at a fixed frequency between 5 Hz and 15 Hz and a fixed displacement amplitude (25,4 mm peak-to-peak amplitude is widely preferred, see Note).

5.1.2 Vibration exciter assembly. In the example introduced in 5.1.1, the vibration exciter consists essentially of a three-phase synchronous a.c. motor and a mechanical excitation unit. The excitation unit itself is composed of a crank-slider mechanism driving the carriage with the turntable, controlled by a stepper motor, on to which the transducer under test is mounted. With a power line frequency of 50 Hz, the synchronous speed, n , is 1 500 r/min for the 4-pole motor in use.

NOTE The use of a 3-phase, 4-pole synchronous motor is not mandatory. To simplify the setup, a special series-wound single-phase motor can be used working in a synchronous way with the power line frequency.

5.1.3 Signal conditioning and data acquisition system. In general, the output of the unit under test requires signal conditioning, including filtering and amplification. The signal conditioning unit may be comprised of a power supply, voltage or charge amplifier, and a 24 dB/octave narrow analogue band-pass filter which can be a combination of a high-pass and a low-pass filter. The filtered signal is connected to the input of the DVM which is in turn connected to a computer via a suitable digital interface. Figure 3 shows a block diagram of an example of a complete signal conditioning and data acquisition system.

5.2 Method

Mount the transducer in a test arrangement such that the known vibratory motion in a plane perpendicular to the sensitive axis is at least 100 times the motion in the direction of the sensitive axis. The frequency and amplitude of the motion shall be stated and shall lie within the rated frequency and amplitude ranges of the transducer. Determine the amplitude of maximum transverse sensitivity and the direction of the maximum and minimum sensitivity by rotating the transducer about its geometric axis of sensitivity.

NOTE Generally, the most interesting parameters are the maximum transverse sensitivity and the direction of the minimum transverse sensitivity.

5.3 Expression of results

Express the output at the maximum transverse sensitivity as a percentage of the output which would be obtained if the known motion were applied in the direction of the geometric axis (Reference [7]).

For further details, see 4.2.2 and Annex A.

6 Determination of transverse sensitivity using a test system with X - and Y -vibration generators

6.1 Apparatus

The transverse test system consists of at least two vibration exciters in the X - Y plane, X - and Y -axis reference accelerometers, a power amplifier and a computer-based acquisition and control system. In Figure 4 and Figure 5, two versions of transverse vibration exciters are shown (see Reference [8] for Figure 4 and Reference [9] for Figure 5). Both are designed to generate vibration in all possible directions in the X - Y plane, yet keeping a fixed angular position of the transducer. This is in contrast with the methods specified in Clause 4, in which the motion is in a single direction and the transducer is turned through all angles to find the direction of maximum transverse sensitivity.

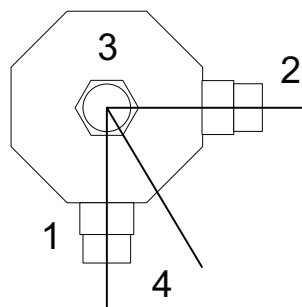
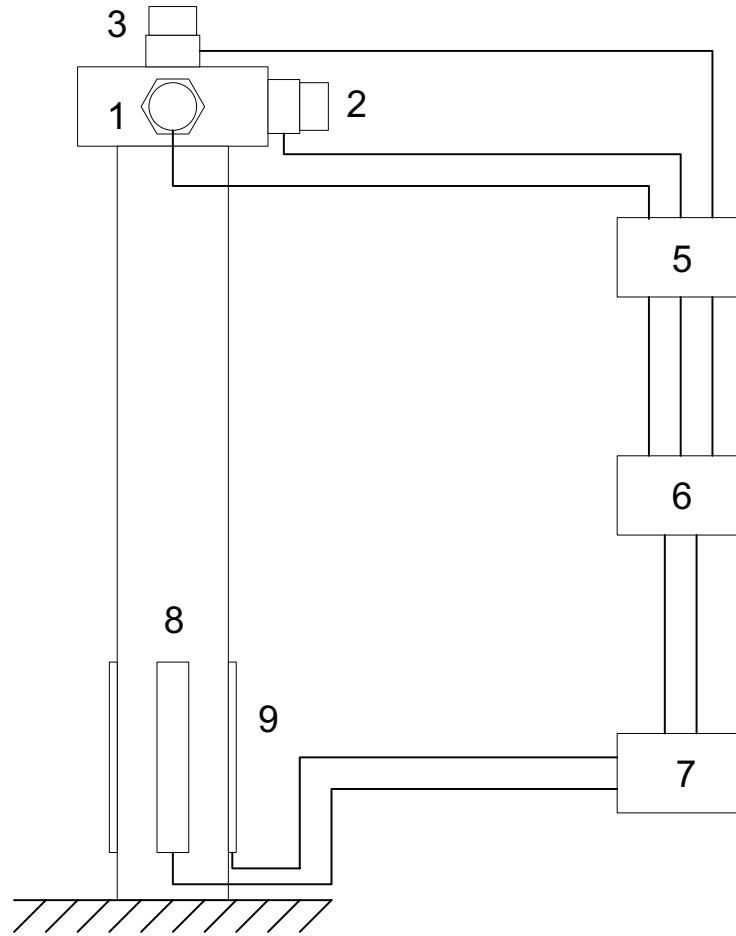

Key

- 1 X-axis reference accelerometer
- 2 Y-axis reference accelerometer
- 3 transducer to be tested
- 4 direction of transverse acceleration
- 5 signal conditioner
- 6 computer, data acquisition, analogue output
- 7 power amplifier
- 8 X-axis actuator
- 9 Y-axis actuator

Figure 4 — Example 1 of a test system with X-Y plate

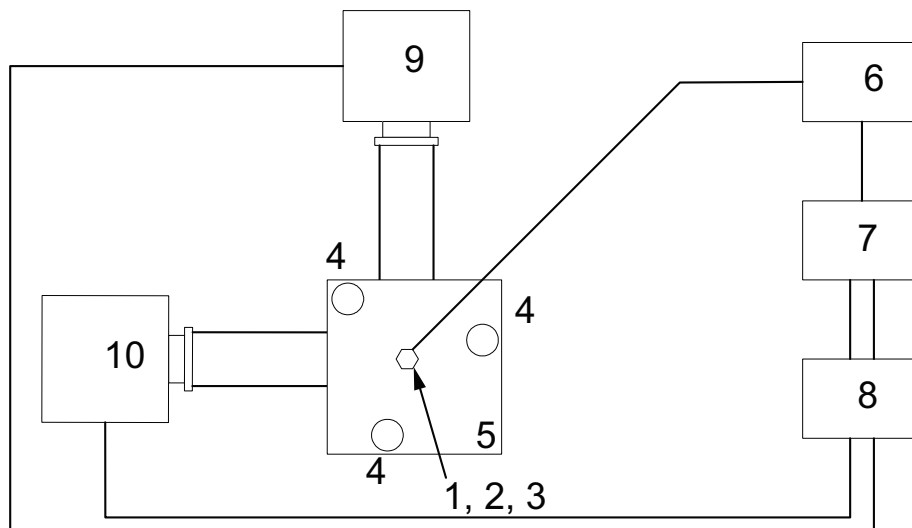
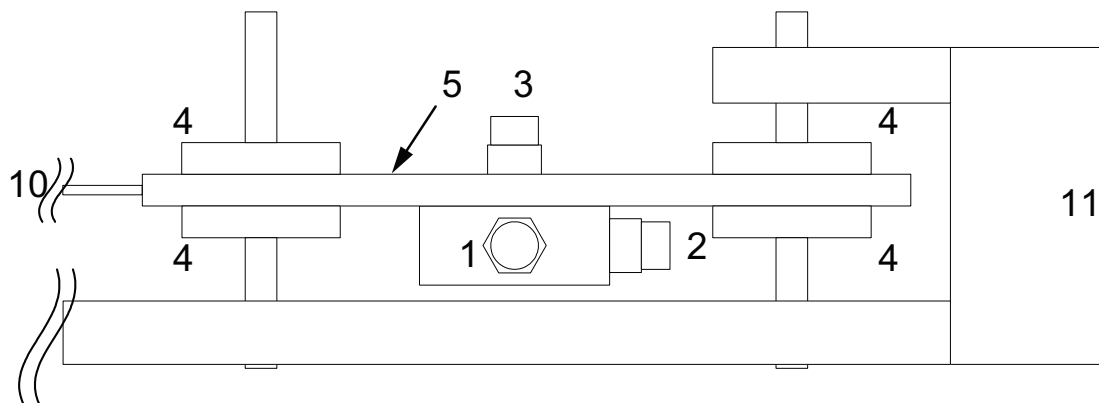

Key

- 1 *X*-axis reference accelerometer
- 2 *Y*-axis reference accelerometer
- 3 transducer to be tested
- 4 air bearing pad
- 5 *X*-*Y* plate
- 6 signal conditioner
- 7 computer, data acquisition, analogue output
- 8 power amplifier
- 9 *X*-axis vibration exciter
- 10 *Y*-axis vibration exciter
- 11 frame

Figure 5 — Example 2 of a test system with *X*-*Y* plate

The first vibration exciter (see Figure 4) (Reference [8]) is a cylindrical rod cantilevered from a heavy base. At the free end of the rod, the transducer to be tested is mounted with the sensitive axis parallel to the rod. Piezoelectric bimorph actuators are attached to the rod, generally driven at the first natural flexural frequency of the rod, to attain the large amplitudes and low-distortion waveforms at resonance.

NOTE The axial rigidity of the rod prevents significant motion in the sensitive direction of the transducer to be tested. The slight angle of the deformed rod generates a longitudinal centripetal acceleration on the geometric axis of sensitivity of the transducer to be tested. If the orbit is perfectly circular (see below), the centripetal acceleration is theoretically static; if the orbit is nominally circular, then the acceleration is quasistatic. The angle is also a source of slight angular acceleration around the X - and Y -axes at the vibration frequency.

The second version (see Figure 5) (Reference [9]) is a flat plate constrained to X - Y motion by air bearings, on which the transducer to be tested is mounted with its sensitive axis normal to the plate. Two or more vibration exciters are used to drive the plate. Attachment from the vibration exciter to the plate is designed to reduce any Z -axis rotational motion (around the sensitive axis of the transducer).

In both systems, two small reference transducers are attached to the mounting block with their geometrical axes in the plane of the motion of the block in close proximity to the transducer to be tested (see Figures 4 and 5). The vibration exciter waveforms are adjusted until the end of the rod moves in the desired pattern.

By driving the X and Y vibration exciters in phase with each other, but varying the relative amplitudes, linear motion in any direction can be obtained. A measurement of transverse sensitivity can be performed at each of a number of directions.

Alternatively, by driving the vibration exciters so that the Y motion is in quadrature with X , that is 90° out of phase with X , a circular orbit can be created. Under these conditions, the centripetal acceleration vector rotates around the transducer to be tested once per period of vibration. The amplitude and phase of the transducer output are analysed, and are compared to the amplitude and phase of the reference transducers. The transverse sensitivity is the ratio of the electrical output to the acceleration input of the transducer to be tested, and the phase of the output with respect to the orbital motion determines the direction of measured transverse sensitivity.

The frequency range of the resonant rod is generally 350 Hz to 500 Hz, depending on the mass of the fixtures and the unit tested. Acceleration amplitudes from 10 m/s^2 to 200 m/s^2 can be generated.

For the flat plate system using two or more vibration exciters, the ranges are generally 5 Hz to 100 Hz in frequency, 10 m/s^2 to 200 m/s^2 in acceleration amplitude and 1 mm to 10 mm in displacement amplitude.

6.2 Method and expression of results

The method is explained in the following for the example shown in Figure 4, for which a detailed description is published (Reference [8]). The computer controls the motion in the X - Y plane, generating approximately circular motion according to Equation (3) and Equation (4) (with $\hat{a}_X = \hat{a}_Y$). Furthermore, the computer acquires the signals of the X - and Y -reference accelerometers and of the transducer to be tested.

The transverse test system generates rectilinear acceleration of the transducer under test in the X - Y plane at a frequency, f . The motion is controlled such that the acceleration component along the X -axis and the acceleration component along the Y -axis are shifted in phase by 90° , according to the relationships:

$$a_X(t) = \hat{a}_X \sin(2\pi ft) \quad (3)$$

$$a_Y(t) = \hat{a}_Y \cos(2\pi ft) \quad (4)$$

where

\hat{a}_X is the amplitude of the acceleration component along the X -axis;

$a_X(t)$ is the time-varying value of the X -axis acceleration;

\hat{a}_Y is the amplitude of the acceleration component along the Y -axis;

$a_Y(t)$ is the time-varying value of the Y -axis acceleration;

f is the frequency of oscillation;

t is time.

In the general case, Equations (3) and (4) describe an elliptical motion in the X - Y plane. If the acceleration amplitudes \hat{a}_X and \hat{a}_Y are equal, then a circle is described.

The magnitude, a , of the acceleration vector, \mathbf{a} , and its direction angle, β , in the X - Y plane, determined at any time, t , are:

$$a(t) = \sqrt{a_X^2(t) + a_Y^2(t)} \quad (5)$$

$$\beta(t) = \tan^{-1} \left[\frac{a_Y(t)}{a_X(t)} \right] \quad (6)$$

The maximum transverse sensitivity, $S_{T, \max}$, of the transducer under test is the maximum of the ratio of the transducer output amplitude, $u_{\text{out}}(t)$, to the magnitude of acceleration, $a(t)$:

$$S_{T, \max} = \max \left[\frac{u_{\text{out}}(t)}{a(t)} \right] \quad (7)$$

where $S_{T, \max}$ is the maximum transverse sensitivity.

The amplitude output, $u_{\text{out}}(t)$, due to transverse motion can be very small if the geometric axis sensitivity (S_N in Figure A.1) of the transducer under test is small, such as in the case of shock accelerometers. In this case, an improved signal resolution can be obtained by using "sine-approximation" techniques (such as those specified in ISO 16063-11^[2]) or fast Fourier transform (FFT) of the acquired signals of the transducer under test and the reference accelerometer.

The spectral components of the outputs of the transducer under test and of the acceleration components, a_X and a_Y , evaluated at the excitation frequency $\omega_2 = 2\pi f$ are the complex quantities:

$$A_X(j\omega_2) = \text{FFT} [a_X(t)]_{\omega_2} \quad (8)$$

$$A_Y(j\omega_2) = \text{FFT} [a_Y(t)]_{\omega_2} \quad (9)$$

$$U_{\text{out}}(j\omega_2) = \text{FFT} [u_{\text{out}}(t)]_{\omega_2} \quad (10)$$

The output of the transducer under test that is in phase with the outputs of the X - and Y - axis reference accelerometer is, respectively:

$$U_X = \text{Re} \left(U_{\text{out}} \frac{A_X^*}{|A_X|} \right) \quad (11)$$

$$U_Y = \text{Re} \left(U_{\text{out}} \frac{A_Y^*}{|A_Y|} \right) \quad (12)$$

where $\text{Re}(\)$ represents the real part of the expression, and $|A_i|$ and A_i^* are the magnitude and complex conjugate of A_i , respectively.

The transverse sensitivities in the X - and the Y -directions are, respectively:

$$S_X = \frac{U_X}{|A_X|} \quad (13)$$

$$S_Y = \frac{U_Y}{|A_Y|} \quad (14)$$

The maximum transverse sensitivity, $S_{T, \max}$, and the angle of maximum transverse sensitivity, $\beta_{T, \max}$, are calculated from Equations (15) and (16), respectively:

$$S_{T, \max} = \sqrt{S_{X, \max}^2 + S_{Y, \max}^2} \quad (15)$$

$$\beta_{T, \max} = \tan^{-1} \left[\frac{S_{Y, \max}}{S_{X, \max}} \right] \quad (16)$$

The angle of minimum transverse sensitivity, $\beta_{T, \min}$, is calculated from:

$$\beta_{T, \min} = \beta_{T, \max} \pm \frac{\pi}{2} \quad (17)$$

7 Determination of the transverse sensitivity using a tri-axial vibration generator

7.1 Apparatus

This transverse test system contains three independent vibration exciters for the X -, Y - and Z -directions, with a cross-coupling unit, appropriate to generate a specified vibration acceleration in the Z -direction in addition to the vibration the X - Y plane, to simulate typical application conditions of the test transducer.

A tri-axial motion generator described in References [10] and [11] (see Figure 6) consists of three linear electro-dynamic vibration exciters which are coupled by a hydrostatic bearing. It can control the vibration frequency and amplitude on three axes (X , Y and Z) independently.

The transverse test system shall be equipped with sub-systems for the measurement of the vibration parameters in the X -, Y - and Z -directions and of the output signal of the test transducer.

In the example of the tri-axial calibration system (References [10] and [11]), three versions of motion measurement systems of the simultaneously generated X , Y , and Z vibration parameters are shown as examples:

- in Figure 6, the tri-axial vibration exciter is equipped with a tri-axial accelerometer;
- in Figure 7, the tri-axial vibration exciter is equipped with three laser interferometers;
- in Figure 8, the tri-axial vibration exciter is equipped with a 3D-laser vibrometer.

For the measurement of the input and output signals of the transducer to be tested, see Clause 8.

The frequency range of the transverse test system is generally 1 Hz to 500 Hz. Acceleration amplitudes from 10 m/s² to 200 m/s² can be generated.

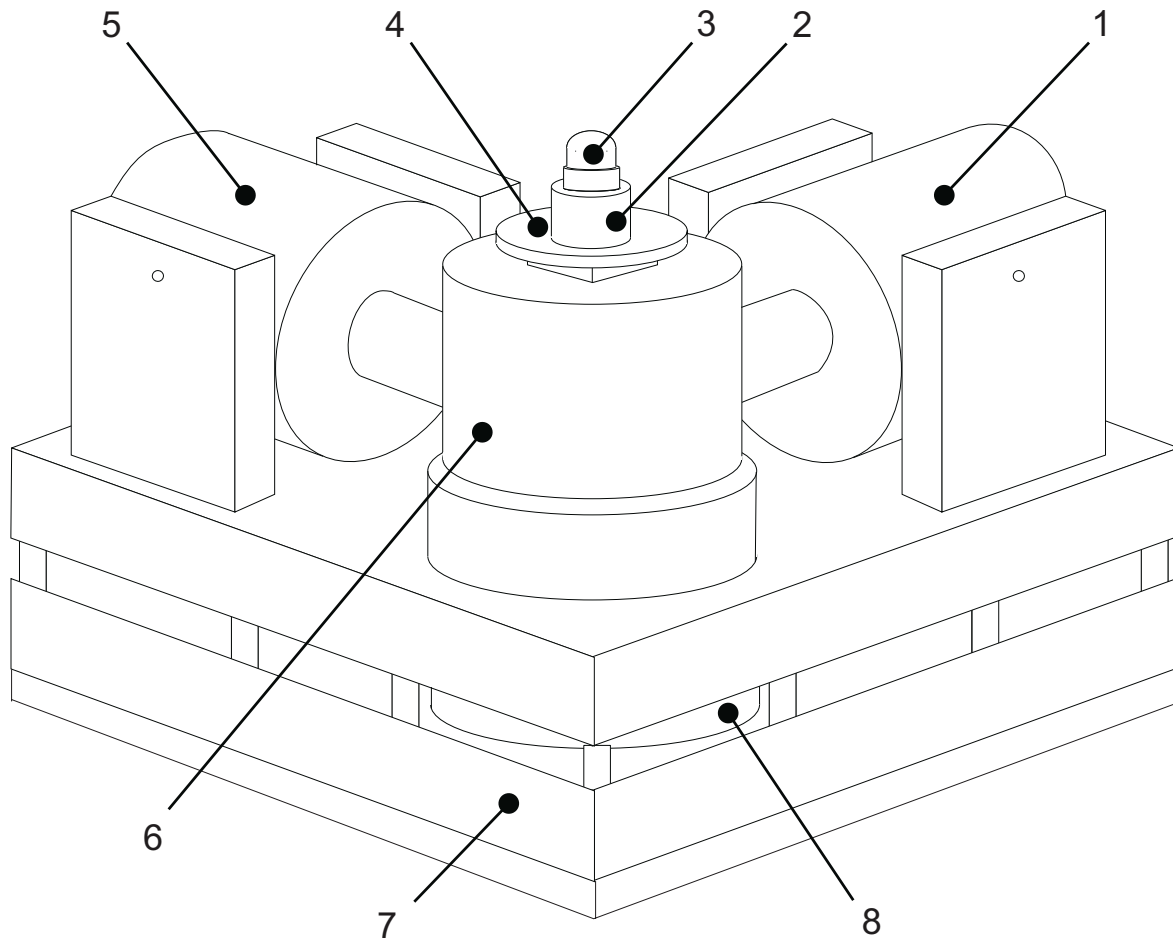

Key

- 1 *X*-exciter
- 2 adapter with tri-axial accelerometer
- 3 transducer to be tested
- 4 vibration exciter table
- 5 *Y*-exciter
- 6 cross-coupling unit
- 7 base with vibration isolation system
- 8 *Z*-exciter

Figure 6 — Example of a tri-axial vibration exciter used for the measurement of the transverse sensitivity equipped with tri-axial accelerometer

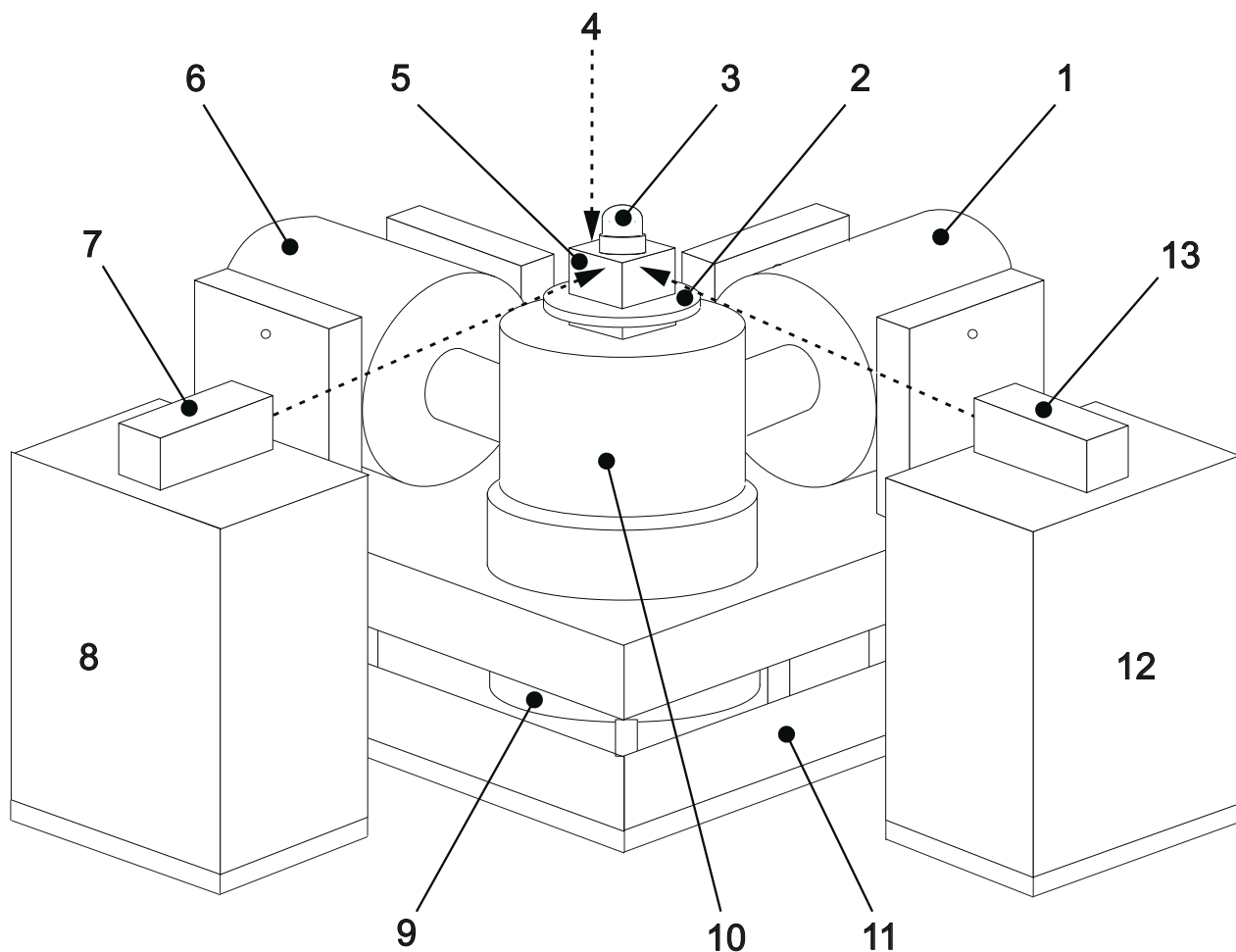

Key

- 1 *X*-exciter
- 2 vibration exciter table
- 3 transducer to be tested
- 4 measuring laser light beam from *Z*-interferometer
- 5 adapter for reflection
- 6 *Y*-exciter
- 7 *X*-interferometer
- 8 vibration isolation block for *X*-interferometer
- 9 *Z*-exciter
- 10 cross-coupling unit
- 11 base with vibration isolation system
- 12 vibration isolation block for *Y*-interferometer
- 13 *Y*-interferometer

Figure 7 — Tri-axial vibration exciter equipped with three laser interferometers

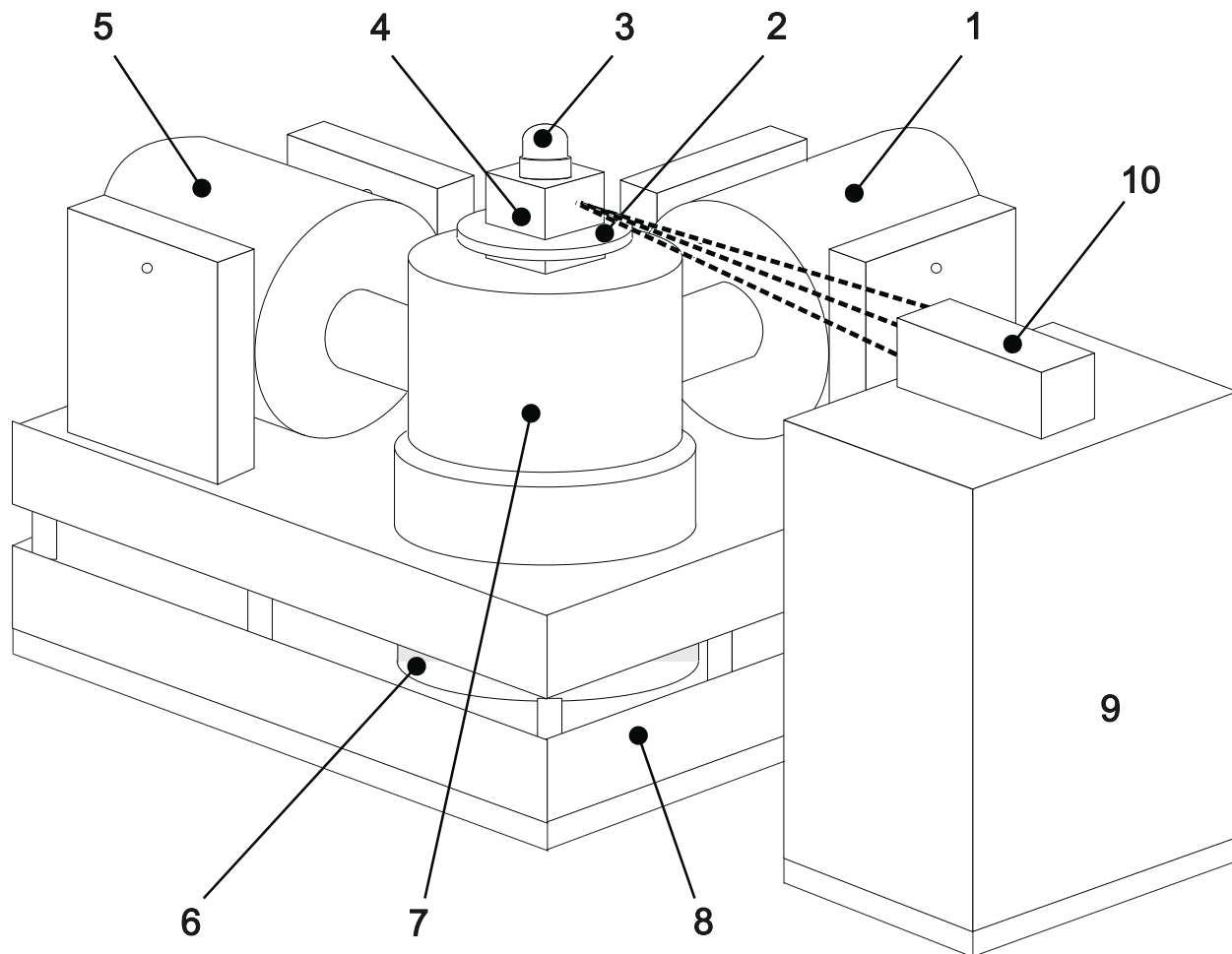

Key

- 1 *X*-exciter
- 2 vibration exciter table
- 3 transducer to be tested
- 4 adapter for reflection
- 5 *Y*-exciter
- 6 *Z*-exciter
- 7 cross-coupling unit
- 8 base with vibration isolation system
- 9 vibration isolation block for 3D-laser vibrometer
- 10 3D-laser vibrometer

Figure 8 — Tri-axial vibration exciter equipped with a 3D-laser vibrometer

7.2 Method and expression of results

The method is briefly explained in the following for the example shown in Figure 6, i.e. using a tri-axial accelerometer. A detailed description of the method is given in Reference [12], with the exception that the tri-axial accelerometer shown in Figure 6 is replaced by four accelerometers in the case of the reference, to observe the motion distribution or any kind of cross-coupling motion caused by the hydraulic bearing.

The test accelerometer is fixed at the centre of the vibrating table made from cast aluminium, having a diameter of 420 mm. The sensing axes of the test accelerometer and the tri-axial accelerometer are aligned to the *Z*-axis of the motion exciter (perpendicular direction). The two remaining axes (*X* and *Y*) of the test accelerometer are aligned to the coordinates. The horizontal motion (*X* and *Y*) is controlled and observed by

the tri-axial accelerometer. This ensures measurement unaffected by any control feedback from the 3-axis vibration excitation system.

The output of each accelerometer is recorded simultaneously in the memory through an analogue-to-digital converter (ADC). The vibration frequencies are independently selected in the Z -direction and in the X - Y plane. The vibration direction in the X - Y plane for the evaluation is changed every 30° .

The acceleration amplitude in the X - Y plane, a_{XY} , is expressed as

$$a_{XY} = \sqrt{a_X^2 + a_Y^2} \quad (18)$$

where a_X and a_Y are acceleration components along the X - and Y -axes, respectively.

The transverse sensitivity of the transducer under test in the direction of $\tan^{-1}(a_Y/a_X)$ is evaluated based on the value a_{XY} . The acceleration components a_X and a_Y correspond to the monitor accelerometers along the X - and Y -axis.

For further information concerning the expression of the results, see 4.2.2.

8 Equipment for measuring of the input and output signals of the transducer to be tested

To measure the transverse sensitivity, the apparatus specified in Clauses 4 and 5 for generating appropriate transverse vibration is to be equipped with a suitable measurement system to meet the uncertainty requirements for the test of the transverse sensitivity of the transducer.

Examples of equipment for measuring the acceleration amplitude or velocity amplitude of the vibration exciter table are:

- a) a piezoelectric accelerometer, a charge amplifier and an r.m.s. voltmeter for simultaneously measuring the acceleration amplitudes in the X -, Y - and Z -directions;
- b) an interferometric laser vibrometer for simultaneously measuring the velocity amplitudes in the X -, Y - and Z -directions;
- c) an interferometric 3D-laser vibrometer for simultaneously measuring the velocity amplitudes in the X -, Y - and Z -directions.

In the case of the tri-axial vibration exciter, a three-channel measuring device is to be used (see Figures 6, 7 and 8) (References [10] and [11]).

An example of equipment for the measurement of the output of the test transducer is a signal amplifier and an r.m.s. voltmeter.

9 Preferred amplitudes and frequencies

The amplitudes of acceleration or velocity shall be chosen so that the signal-to-noise ratio of the transducer output signal is sufficient for an accurate measurement of the amplitude of the transducer output signal.

The frequencies shall be chosen from the standardized one-third-octave frequency series (ISO 266) between 1 Hz and 5 kHz (or the series of radian frequencies evolving from $\omega = 1\,000$ rad/s).

Annex A (normative)

Definition of transverse sensitivity

The transverse sensitivity of an accelerometer is the sensitivity to acceleration applied at right angles to its geometric axis, and the transverse sensitivity of a velocity transducer is the sensitivity to a velocity applied at right angles to its geometric axis.

The sensitive axis of the transducer is not necessarily aligned with the geometric axis, as shown in Figure A.1. If the transducer is placed in a rectangular co-ordinate system, as shown in Figure A.1, the vector S_{\max} (representing the direction and the magnitude of maximum sensitivity) can be resolved into two components: the geometric axis of sensitivity along which the transducer has a sensitivity S_N and the axis of maximum transverse sensitivity along which the transducer has a maximum transverse sensitivity $S_{T, \max}$.

The theoretical transverse sensitivity curve is shown in Figure A.2. The transverse sensitivity is expressed as a percentage of the geometric axis sensitivity (it is dependent on the excitation angle).

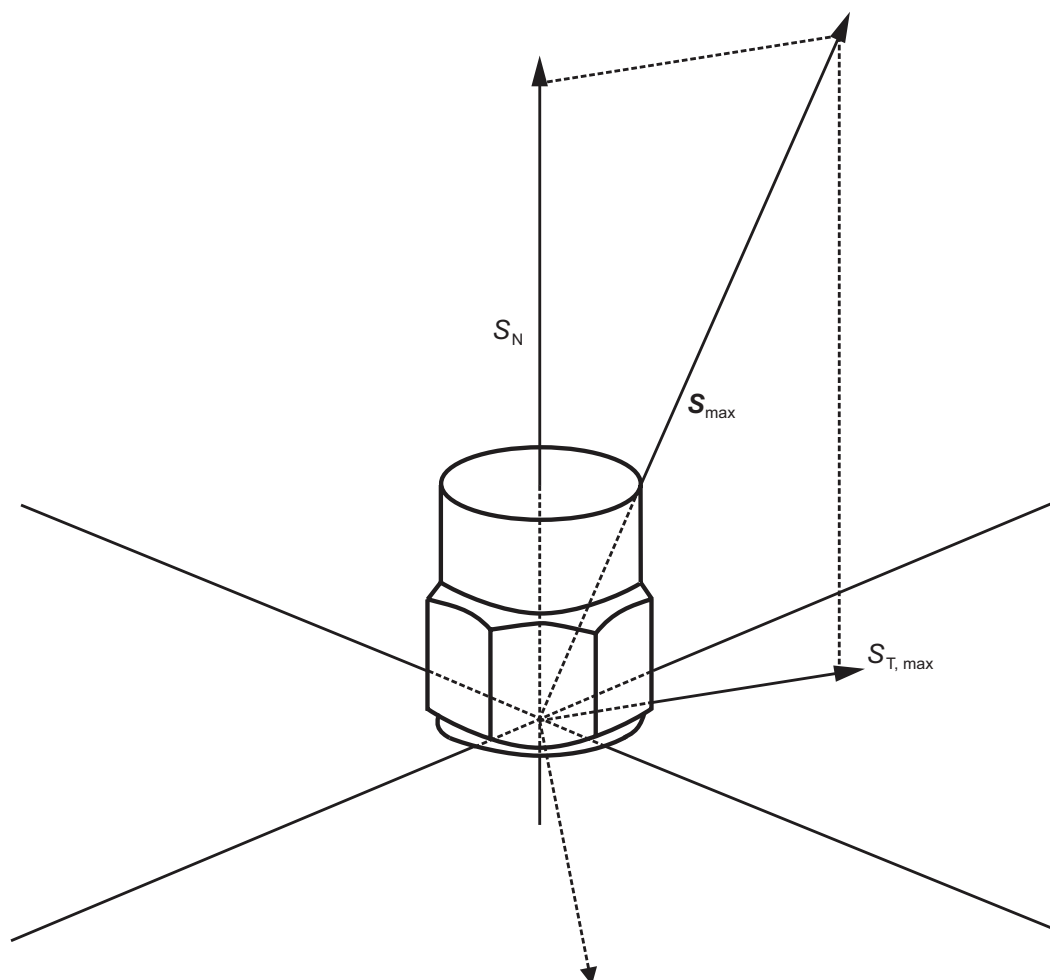

Key

- S_{\max} vector representing the direction and magnitude of maximum sensitivity
- S_N magnitude of sensitivity on the geometric axis of sensitivity
- $S_{T, \max}$ magnitude of maximum transverse sensitivity

Figure A.1 — Graphical illustration of transverse sensitivity

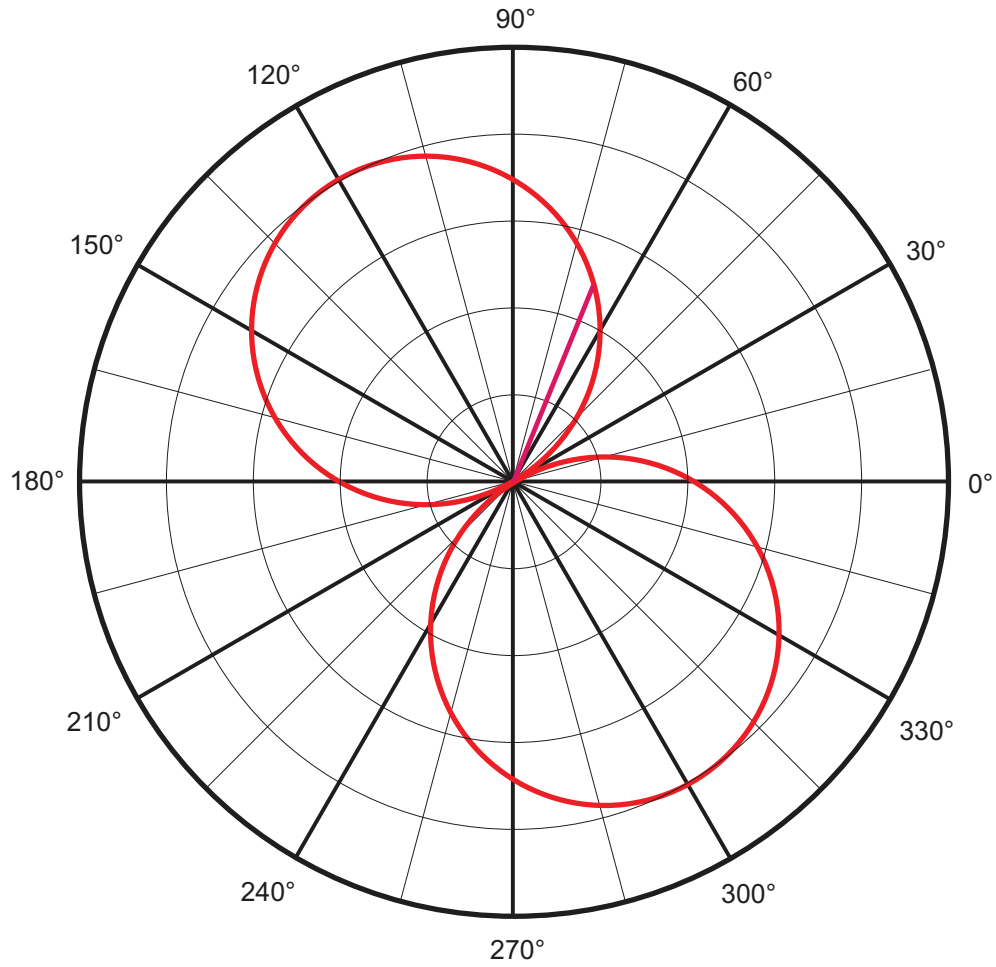

Figure A.2 — Typical theoretical polar pattern of transverse sensitivity as a function of angular orientation in the plane normal to the geometric axis of sensitivity of the transducer

Bibliography

- [1] ISO 2041, *Mechanical vibration, shock and condition monitoring — Vocabulary*
- [2] ISO 16063-11, *Methods for the calibration of vibration and shock transducers — Part 11: Primary vibration calibration by laser interferometry*
- [3] ISO 16063-21, *Methods for the calibration of vibration and shock transducers — Part 21: Vibration calibration by comparison to a reference transducer*
- [4] ISO/IEC Guide 98-3, *Uncertainty of measurement — Part 3: Guide to the expression of uncertainty in measurement (GUM:1995)*
- [5] ASMW-Vorschrift Messwesen ASMW VM 1273 (Sept. 1987), *Mechanische Schwingungen — Beschleunigungsaufnehmer und Schwingungserreger — Zulassungs- und Eichvorschrift für Referenznormale [Mechanical vibrations — Accelerometers and vibration exciters — Regulation for pattern approval and verification of reference standards]*
- [6] ISA-RP 37.2-1982 (R1995), *Guide for specifications and tests for piezoelectric acceleration transducers for aerospace testing*
- [7] PETZSCHE, T. Determination of the transverse sensitivity using a mechanical vibration generator with turntable. ISO TC 108/SC 3/WG 6 Doc. N153 (2007)
- [8] DOSCH, J.J., LALLY, M.L. Automated testing of accelerometer transverse sensitivity. In: *Proceedings of the International Modal Analysis Conference*, pp. 1-4. IMAC, Kissimee, FL, USA, 2003
- [9] SILL, R.D., SELLER, E.J. Accelerometer transverse sensitivity measurement using planar orbital motion. In: *Proceedings of the 77th Shock and Vibration Symposium*, pp. 8-12. Monterey, CA, USA, Nov. 2006. Available (2009-03-12) at: http://www.pcb.com/techsupport/docs/vib/AR-86_Transverse_Sensitivity.pdf
- [10] VON MARTENS, H.-J., WEISSENBORN, C. Simultaneous multi-component calibration — A new research area in the field of vibration and shock. 1st Meeting of the Consultative Committee for Acoustics, Ultrasound and Vibration. Bureau International de Poids et Mesures, Sèvres, France, 1999
- [11] WEISSENBORN, C. A new measurement system for simultaneous multicomponent calibration of motion transducers. In: *Proceedings of the 9th International Conference for Sensors, Transducers and Systems (Sensor 99)*. Nürnberg, Germany (1999)
- [12] USUDA, T., WEISSENBORN, C., VON MARTENS, H.-J. Theoretical and experimental investigation of transverse sensitivity of accelerometers under multiaxial excitation. *Meas. Sci. Technol.* 2004, **15**, pp. 896-904

ICS 17.160

Price based on 18 pages

BSI - British Standards Institution

BSI is the independent national body responsible for preparing British Standards. It presents the UK view on standards in Europe and at the international level. It is incorporated by Royal Charter.

Revisions

British Standards are updated by amendment or revision. Users of British Standards should make sure that they possess the latest amendments or editions.

It is the constant aim of BSI to improve the quality of our products and services. We would be grateful if anyone finding an inaccuracy or ambiguity while using this British Standard would inform the Secretary of the technical committee responsible, the identity of which can be found on the inside front cover. Tel: +44 (0)20 8996 9000. Fax: +44 (0)20 8996 7400.

BSI offers members an individual updating service called PLUS which ensures that subscribers automatically receive the latest editions of standards.

Buying standards

Orders for all BSI, international and foreign standards publications should be addressed to Customer Services. Tel: +44 (0)20 8996 9001. Fax: +44 (0)20 8996 7001 Email: orders@bsigroup.com You may also buy directly using a debit/credit card from the BSI Shop on the Website <http://www.bsigroup.com/shop>

In response to orders for international standards, it is BSI policy to supply the BSI implementation of those that have been published as British Standards, unless otherwise requested.

Information on standards

BSI provides a wide range of information on national, European and international standards through its Library and its Technical Help to Exporters Service. Various BSI electronic information services are also available which give details on all its products and services. Contact Information Centre. Tel: +44 (0)20 8996 7111 Fax: +44 (0)20 8996 7048 Email: info@bsigroup.com

Subscribing members of BSI are kept up to date with standards developments and receive substantial discounts on the purchase price of standards. For details of these and other benefits contact Membership Administration. Tel: +44 (0)20 8996 7002 Fax: +44 (0)20 8996 7001 Email: membership@bsigroup.com

Information regarding online access to British Standards via British Standards Online can be found at <http://www.bsigroup.com/BSOL>

Further information about BSI is available on the BSI website at <http://www.bsigroup.com>

Copyright

Copyright subsists in all BSI publications. BSI also holds the copyright, in the UK, of the publications of the international standardization bodies. Except as permitted under the Copyright, Designs and Patents Act 1988 no extract may be reproduced, stored in a retrieval system or transmitted in any form or by any means – electronic, photocopying, recording or otherwise – without prior written permission from BSI.

This does not preclude the free use, in the course of implementing the standard, of necessary details such as symbols, and size, type or grade designations. If these details are to be used for any other purpose than implementation then the prior written permission of BSI must be obtained.

Details and advice can be obtained from the Copyright and Licensing Manager. Tel: +44 (0)20 8996 7070 Email: copyright@bsigroup.com