

BS ISO 16049-2:2013



BSI Standards Publication

# Air cargo equipment — Restraint straps

Part 2: Utilization guidelines and lashing  
calculations

**bsi.**

...making excellence a habit.™

**National foreword**

This British Standard is the UK implementation of ISO 16049-2:2013.

The UK participation in its preparation was entrusted to Technical Committee ACE/57, Air cargo and ground support equipment.

A list of organizations represented on this committee can be obtained on request to its secretary.

This publication does not purport to include all the necessary provisions of a contract. Users are responsible for its correct application.

© The British Standards Institution 2013. Published by BSI Standards Limited 2013

ISBN 978 0 580 79163 5

ICS 49.120

**Compliance with a British Standard cannot confer immunity from legal obligations.**

This British Standard was published under the authority of the Standards Policy and Strategy Committee on 31 May 2013.

**Amendments issued since publication**

Date	Text affected
------	---------------

---

---

---

**Air cargo equipment — Restraint  
straps —**

Part 2:  
**Utilization guidelines and lashing  
calculations**

*Équipement de fret aérien — Sangles d'arrimage —*

*Partie 2: Directives pour l'utilisation et calculs d'arrimage*





**COPYRIGHT PROTECTED DOCUMENT**

© ISO 2013

All rights reserved. Unless otherwise specified, no part of this publication may be reproduced or utilized otherwise in any form or by any means, electronic or mechanical, including photocopying, or posting on the internet or an intranet, without prior written permission. Permission can be requested from either ISO at the address below or ISO's member body in the country of the requester.

ISO copyright office  
Case postale 56 • CH-1211 Geneva 20  
Tel. + 41 22 749 01 11  
Fax + 41 22 749 09 47  
E-mail [copyright@iso.org](mailto:copyright@iso.org)  
Web [www.iso.org](http://www.iso.org)

Published in Switzerland

# Contents

	Page
<b>Foreword</b> .....	<b>iv</b>
<b>Introduction</b> .....	<b>v</b>
<b>1 Scope</b> .....	<b>1</b>
<b>2 Normative references</b> .....	<b>1</b>
<b>3 Terms and definitions</b> .....	<b>2</b>
<b>4 General requirements</b> .....	<b>4</b>
<b>5 Tie-down method</b> .....	<b>7</b>
5.1 Basic method.....	7
5.2 Directions of restraint.....	7
<b>6 Calculation methods</b> .....	<b>8</b>
6.1 Load factors.....	8
6.2 Calculation principles.....	9
6.3 Practical calculation.....	10
<b>7 Specific requirements</b> .....	<b>11</b>
7.1 General.....	11
7.2 Risk of cargo slippage.....	11
7.3 Risk of cargo tilting.....	11
7.4 Long and narrow items.....	12
<b>8 Operator's responsibilities</b> .....	<b>12</b>
<b>Bibliography</b> .....	<b>14</b>

## Foreword

ISO (the International Organization for Standardization) is a worldwide federation of national standards bodies (ISO member bodies). The work of preparing International Standards is normally carried out through ISO technical committees. Each member body interested in a subject for which a technical committee has been established has the right to be represented on that committee. International organizations, governmental and non-governmental, in liaison with ISO, also take part in the work. ISO collaborates closely with the International Electrotechnical Commission (IEC) on all matters of electrotechnical standardization.

The procedures used to develop this document and those intended for its further maintenance are described in the ISO/IEC Directives, Part 1. In particular the different approval criteria needed for the different types of ISO documents should be noted. This document was drafted in accordance with the editorial rules of the ISO/IEC Directives, Part 2. [www.iso.org/directives](http://www.iso.org/directives)

Attention is drawn to the possibility that some of the elements of this document may be the subject of patent rights. ISO shall not be held responsible for identifying any or all such patent rights. Details of any patent rights identified during the development of the document will be in the Introduction and/or on the ISO list of patent declarations received. [www.iso.org/patents](http://www.iso.org/patents)

Any trade name used in this document is information given for the convenience of users and does not constitute an endorsement.

The committee responsible for this document is ISO/TC 20, *Aircraft and space vehicles*, Subcommittee SC 9, *Air cargo and ground equipment*.

This second edition cancels and replaces the first edition (ISO 16049-2:2005), which has been technically revised. It was technically revised to fully meet the requirements of Technical Standard Order (TSO/ETSO) C-172.

ISO 16049 consists of the following parts, under the general title *Air cargo equipment — Restraint straps*:

- *Part 1: Design criteria and testing methods*
- *Part 2: Utilization guidelines and lashing calculations*

## Introduction

This part of ISO 16049 specifies utilization guidelines and the principles to be used in tie-down/lashing strength calculations for the use of air cargo restraint straps on board civil transport aircraft.

Throughout this part of ISO 16049, the minimum essential criteria are identified by use of the key word “shall”. Recommended criteria are identified by use of the key word “should” and, while not mandatory, are considered to be of primary importance in providing safe lashing arrangements. Deviation from recommended criteria should only occur after careful consideration and thorough service evaluation have shown alternate methods to be satisfactory.





# Air cargo equipment — Restraint straps —

## Part 2: Utilization guidelines and lashing calculations

### 1 Scope

**1.1** This part of ISO 16049 aims to provide general utilization guidelines and calculation methods adequate to guarantee the effectiveness and ultimate load strength of tie-down/lashing arrangements performed to restrain cargo on board civil transport aircraft during flight:

- a) cargo loaded and tied down onto airworthiness approved air cargo pallets, themselves restrained into aircraft lower deck or main deck or upper deck cargo systems meeting the restraint requirements of air cargo pallets approved in accordance with ISO 8097, (NAS3610) or ISO/PAS 21100, or
- b) additional tie-down on aircraft structure when necessitated by pallet maximum gross mass or centre of gravity limits, or
- c) non-unitized individual pieces of cargo, or pieces of cargo placed onto an unrestrained (“floating”) pallet into either lower deck, main deck or upper deck containerized cargo compartments of an aircraft, or
- d) individual pieces of load loaded in non-containerized (bulk loaded) baggage or cargo compartments.

**1.2** This part of ISO 16049 applies to cargo tie-down/lashing arrangements using exclusively air cargo restraint straps conforming to ISO 16049-1. Its general recommendations may also be used for tie-down arrangements using other means (e.g. steel cables, rope, other types of straps), but under the user’s responsibility as to their adequacy and the strength calculations required.

NOTE 1 Where tie-down is performed onto aircraft structure as per 1.1 b) or c), additional restrictions can be stated in the aircraft’s Authority approved Weight and Balance Manual.

NOTE 2 The use of chains or other rigid devices for tie-down onto civil transport aircraft floor tracks is not part of the scope of this part of ISO 16049, since it is not recommended due to the possibility of generating excessive stresses in the aircraft structure, except where explicitly approved in the manufacturer’s Authority approved Weight and Balance Manual.

**1.3** This part of ISO 16049 aims to provide industry recognized means of complying with Airworthiness Authorities general regulations applicable to load securing on board civil transport aircraft (see 14 CFR Part 25 and EASA CS-25), and aircraft manufacturers Authority approved Weight and Balance Manuals for each aircraft type as specified therein. It is not the intent of this part of ISO 16049 to specify when restraint straps should be used, but how they should be used. It does not, under any circumstance, supersede the requirements of any of the above documents that take precedence at all times.

### 2 Normative references

The following referenced documents are indispensable for the application of this document. For dated references, only the edition cited applies. For undated references, the latest edition of the referenced document (including any amendments) applies.

ISO 7166, *Aircraft — Rail and stud configuration for passenger equipment and cargo restraint*

ISO 8097:2001, *Aircraft — Minimum airworthiness requirements and test conditions for certified air cargo unit load devices*<sup>1)</sup>

1) Endorsement of NAS 3610 revision 10, TSO/ETSO/CTSO/JTSC C-90c.

ISO 9788, *Air cargo equipment — Cast components of double stud fitting assembly with a load capacity of 22 250 N (5 000 lbf), for aircraft cargo restraint*

ISO 10254, *Air cargo and ground equipment — Vocabulary*

ISO 16049-1, *Air cargo equipment — Restraint straps — Part 1: Design criteria and testing methods*

ISO/PAS 21100, *Air cargo unit load devices — Performance requirements and test parameters (TSO/ETSO/CTSO/JTSO C-90d)*

CAAC CCAR-25, *Airworthiness Standards — Transport Category Airplanes*

European Aviation Safety Agency (EASA) Certification Specification CS-25, *Airworthiness Standards: transport category aeroplanes*<sup>2)</sup>

EASA European Technical Standard Order ETSO C172 — *Cargo Restraint Strap Assemblies*<sup>3)</sup>

European Aviation Safety Agency (EASA) EU-OPS 1.035, *Quality system*<sup>4)</sup>

Japanese Airworthiness Standard Part 3 (Civil Aeronautics Law Article 10 § 4)<sup>5)</sup>

USA Code of Federal Regulations (CFR) Title 14 Part 25, *Airworthiness Standards: transport category airplanes*. (“14 CFR Part 25”)<sup>6)</sup>

USA Federal Aviation Administration Technical Standard Order TSO C172 — *Cargo Restraint Strap Assemblies*<sup>7)</sup>

Federal Aviation Administration (FAA) Advisory Circular AC 120-59, *Air carriers internal evaluation programs*<sup>8)</sup>

NOTE Also see other informative references in Bibliography.

### 3 Terms and definitions

For the purposes of this document, the terms and definitions given in ISO 10254 and the following apply.

#### 3.1 tie-down lashing

fact of restraining cargo movements in relation to an aircraft's structure, throughout the range of relative accelerations resulting from the allowable flight envelope, by means of an appropriate use of a number of elementary tie-down devices against each direction of restraint

---

2) EASA CS-25 constitutes the European governments transport aircraft airworthiness Regulations, and can, as well as EU-OPS, be obtained from European Aviation Safety Agency (EASA), Otto Platz 1, Postfach 101253, D-50452 Cologne, Germany, or its web site at <http://www.easa.europa.eu/>.

3) See footnote 2.

4) See footnote 2.

5) The Japanese Airworthiness Standard Part 3 (ISBN 4-89279-661-1) constitutes the Japanese government transport aircraft airworthiness approval Regulations, and can be obtained from the Civil Aviation Bureau (CAB) of the Ministry of Land, Infrastructure, Tourism and Transport, Tokyo, Japan, or its web site at <http://www.mlit.go.jp/en>.

6) The Code of Federal Regulations (CFR) Title 14 Part 25, abbreviated throughout this standard as “14 CFR Part 25”, constitutes the USA government transport aircraft airworthiness Regulations, and can be obtained from the US Government Printing Office, Mail Stop SSOP, Washington DC 20402-9328, USA, or its website at <http://www.gpoaccess.gov/>. Advisory Circulars can be obtained from the FAA at its website <http://www.faa.gov/>.

7) See footnote 6.

8) See footnote 6.

### 3.2

#### **tie-down arrangement**

geometric layout of an assembly of elementary tie-down devices affixed and tensioned around a piece of cargo in order to ensure its tie-down against each direction of restraint

### 3.3

#### **flight envelope**

set, during flight of a given aircraft type or sub-type, of allowable values for accelerations which may be encountered during flight in the various directions relative to the aircraft's structure, as determined during the aircraft certification flight testing and certified by the Airworthiness Authority within the aircraft's type certificate

### 3.4

#### **limit load**

##### **LL**

maximum load to be expected in service as a result of the certified flight envelope of the aircraft

Note 1 to entry: It is two thirds of the ultimate load (see 3.5).

### 3.5

#### **ultimate load**

##### **UL**

limit load multiplied by a safety factor of 1,5 prescribed by 14 CFR Part 25 and CS-25, paragraph 25.303

Note 1 to entry: It is used for calculation of cargo tie-down arrangements, based on the ultimate load factors defined in the Airworthiness Authority approved Weight and Balance Manual, in each direction of restraint, throughout the certified flight envelope of the aircraft type.

### 3.6

#### **fore and aft**

directions of restraint, relative to the aircraft structure, determined parallel to the aircraft centreline towards the direction of flight, or opposed to it

### 3.7

#### **sides**

directions of restraint, relative to the aircraft structure, determined perpendicular to the aircraft centreline and parallel to its floor, lefthand or righthand

### 3.8

#### **upward**

upward direction relative to the aircraft structure

### 3.9

#### **load factors**

accelerations, expressed as multiples of the standard acceleration of gravity ( $g = 9,806\ 65\ \text{m.s}^{-2}$ ), in each direction of restraint (fore, aft, sides, upward), that will result in limit or ultimate, as is the case, forces on the tie-down arrangement proportional to the mass of the piece of cargo being restrained

Note 1 to entry: They are provided by Airworthiness Authority approved Weight and Balance Manual for aircraft type or sub-type.

Note 2 to entry: The load factors may be limit or ultimate.

### 3.10

#### **restraint strap assembly**

##### **strap**

basic tie-down unit consisting of flat woven textile webbing (one fixed end and one adjustable end), one tensioning device and two end fittings, used for restraint of cargo on board civil transport aircraft

Note 1 to entry: See ISO 16049-1 for description, design criteria and testing requirements.

### 3.11 **(tie-down) fitting**

basic piece of hardware, either single stud (see ISO 7166) or double stud (see ISO 9788), with an omnidirectional capability, allowing to attach (a) strap(s) or other elementary tie-down unit(s) to the floor tracks or tie-down receptacles of an aircraft's structure or the edge tracks of an air cargo pallet

Note 1 to entry: Tie-down fittings most commonly include an attachment ring, but may also be directly sewn onto a strap as a permanent end fitting thereof (see ISO 16049-1).

### 3.12 **floating**

<pallet> air cargo pallet, or equivalent flat support device, located on an aircraft's cargo compartment rollerized conveyor but not restrained by the cargo system, the pallet and its load constituting "non unitized" cargo and being restrained by a set of straps attached to aircraft structural points

### 3.13 **competent person**

designated person, suitably trained according to [6.2.2](#) of ISO 9001:2008 or equivalent pertinent industry training and proficiency standards, qualified by knowledge and practical experience and with the necessary operating instructions established according to [4.1](#)

## 4 General requirements

**4.1** Operating instructions shall be established by the aircraft operator, under control of his/her reporting Civil Aviation Authority. The operating instructions shall ensure compliance with the general airworthiness requirements and the applicable aircraft Weight and Balance Manual, and should incorporate the requirements of this part of ISO 16049, or equivalent industry standard (see Bibliography).

**4.2** In addition, when restraint straps are attached to the edge rails of a certified air cargo pallet meeting the requirements of ISO 8097 (NAS 3610) or ISO/PAS 21100, operating instructions shall take into account the general requirements of the appropriate ISO 8097 (NAS 3610) or ISO/PAS 21100 configuration drawing(s) as to tie-down points locations and spacing.

**4.3** Actual tie-down/lashing on aircraft in accordance with these instructions shall be performed and checked exclusively by competent, suitably trained, personnel as defined in 6.2.2 of ISO 9001:2008 or equivalent pertinent industry training and proficiency standards (see [Clause 8](#)).

**4.4** Regardless of the tie-down method used (see [Clause 5](#)), all the following rules shall be complied with.

**4.5** Tie-down shall be performed using straps designed and tested in accordance with ISO 16049-1 and Authority approved under TSO/ETSO/CTSO JTSO C172, onto tracks or receptacles meeting the requirements of ISO 7166, and using fittings meeting the requirements of either ISO 7166 (single stud) or ISO 9788 (double stud).

The rated ultimate strength resulting from testing of the strap model used shall be used for calculation of the tie-down arrangement's strength (see [Clause 6](#)), using the safety factor of 1,5 prescribed by 14 CFR Part 25 and CS-25, paragraph 25.303. In the event of other straps or alternative tie-down equipment (e.g. ropes, cables) being used under the operator's responsibility, the following general rules shall nevertheless apply, and the minimum guaranteed ultimate strength of the specific equipment used shall be used for strength calculation.

**4.6** If several elements (e.g. straps, fittings, structural attachment points) of different ultimate strengths are used together, the strength of the resulting total tie-down element shall be limited to the strength of the weakest item.

**4.7** A total tie-down arrangement should be performed using exclusively straps of the same model, in order to ensure differences in elasticity will not result in unequal tension of the straps and premature failure of certain ones in the event of a major acceleration being encountered during flight. If different models must be used, at least the straps material (e.g. polyamide, polyester, etc.) and rated ultimate strength shall be identical for any single direction of restraint.

**4.8** Tie-down arrangements shall be symmetrical, i.e. performed using an equal number of tie-down attachment points (fittings or equivalent) on any two opposite sides of the piece of cargo, and the same number of straps, acting in the same direction(s) of restraint, onto any two symmetrically located attachment points. See [Figure 1](#).

**4.9** A single tie-down fitting may, subject to ring geometrical compatibility and any Weight and Balance Manual restrictions or limits as to load factors simultaneity, be attached to up to three straps acting in as many different directions, but shall be attached to no more than one acting in any single direction of restraint (fore, aft, side or upward).

**4.10** A strap attached to fittings on opposite sides of the piece of cargo and passing over or around it is to be accounted for twice its rated ultimate load capacity, under the condition it remains free to slide along the piece of cargo and not attached to it, so that the load is equally distributed between both ends of the strap. A strap attached to the piece of cargo may be accounted for only once.

**4.11** For upward restraint, a minimum of two straps, regardless of the mass to be restrained, shall be used over the top of the piece of cargo, one on each side of its centre of gravity. When a higher number of upward straps is used, they should be evenly distributed around the centre of gravity.

**4.12** Each strap should make a minimum possible angle, not to exceed  $30^\circ$ , with the direction of restraint for which it is accounted for (see [Figure 1](#)). In practical terms, to ensure angles  $a_1$ ,  $a_2$ ,  $a_3$  on the figure are no more than  $30^\circ$  in relation to, respectively, directions A, B and C, it should be checked that distances  $d_1$ ,  $d_2$  and  $d_3$ , respectively, are less than half of distances  $D_1$ ,  $D_2$  and  $D_3$ .

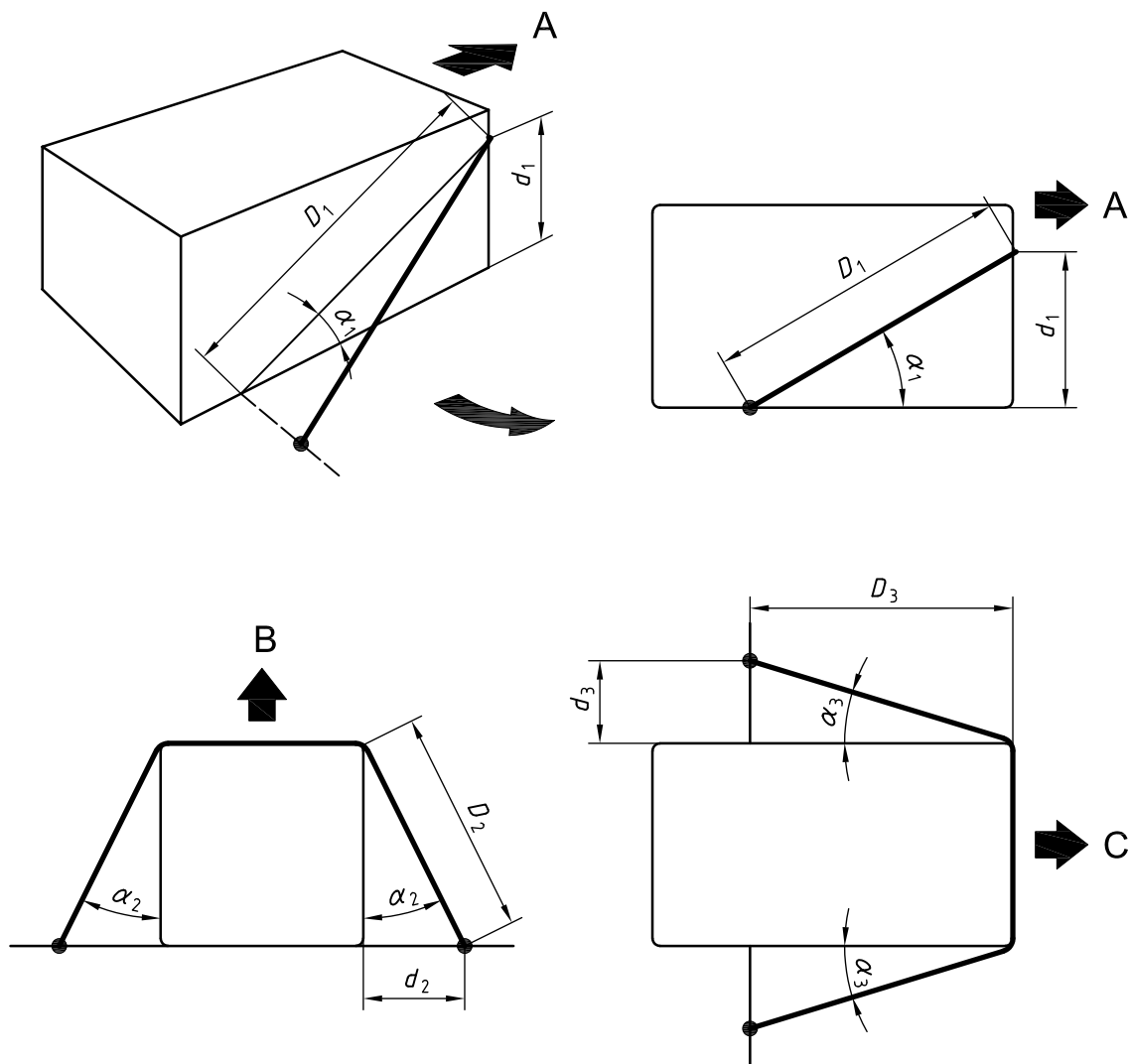

Figure 1 — Angles definition

4.13 A minimum distance of 0,5 m (20 in) shall be maintained between any two tie-down attachment points (fittings) bearing straps, ensuring restraint in the same direction (see examples in [Figure 2](#)).

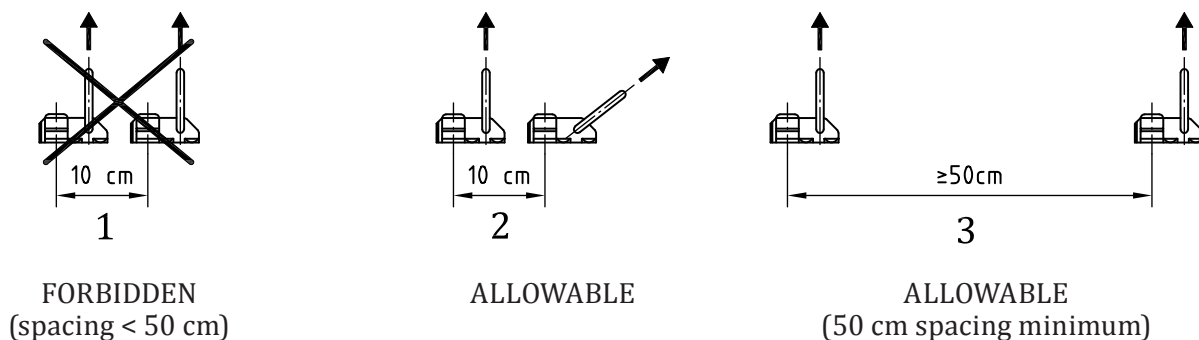

Figure 2 — Minimum distances

4.14 All straps bearing in the same direction of restraint shall be equally tensioned as much as is feasible in order to ensure they equally bear the restraint forces in the event of an in-flight load. Straps should

be tensioned without any slack, but without excess. Particularly, when using an aluminium sheet pallet, care should be taken not to bend the pallet's edge rail upward. Applying to all straps the residual tension defined in ISO 16049-1 usually results in complying with these requirements.

For ratchet type tensioning devices (see indexes C1 or C2 of ISO 16049-1:2013, Figure 1), there shall be a minimum of two full webbing wraps around the mandrel, cylinder, spool or equivalent once the strap is fully tensioned.

**4.15** Care should be taken that any straps passing over or around the piece(s) of cargo cannot come in contact with sharp or cutting edges capable of cutting into the strap's webbing, or, if unavoidable, to provide padding adequate to protect it.

**4.16** Care should be taken to provide positive protection against the risk of downward sliding of any straps bearing in a horizontal direction of restraint, either by tightening them immediately over an adequate protrusion of the load, e.g. horizontal batten or comparable protrusion in a wooden crate's wall, etc., or, if not available, attaching them with a security rope over the load, capable of maintaining their location.

## 5 Tie-down method

### 5.1 Basic method

Cargo restraint shall be ensured by a dedicated set of straps in a given set of directions of restraint. See [Figure 3](#).

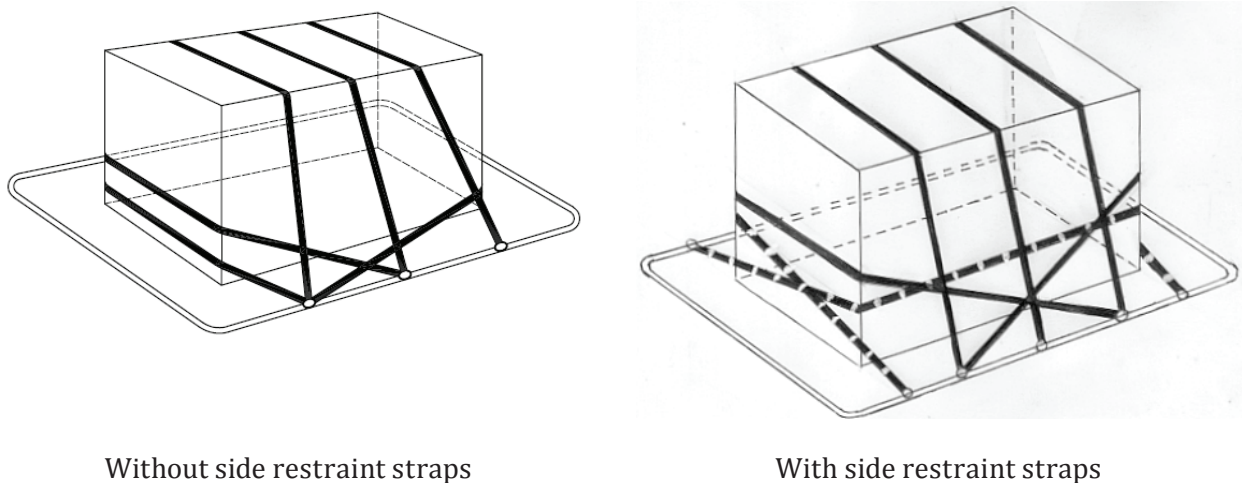

**Figure 3 — Examples of tie-down arrangements** (see [5.2](#))

**NOTE 1** Where the number of straps is different in the different horizontal directions, the load may only be loaded in the correct orientation within the aircraft. Appropriate loading instructions must be given, and maintained in the event of a trans-shipment. See [6.1.2](#).

**NOTE 2** See [Clause 7](#) for additional precautions applying to different special shapes of cargo.

### 5.2 Directions of restraint

**5.2.1** Whatever method used, restraint in each of the four required horizontal directions (forward, aft, both sides) may be ensured by either a dedicated set of straps for an individual direction, or the general effect of the straps assembly forming a net like tie-down arrangement, equivalent, though less deformable, to a certified pallet net, to provide multidirectional restraint. See [Figure 3](#).

**5.2.2** Upward restraint is not achieved by a net like effect, and shall be ensured by a dedicated set of straps. An even number of upward restraint straps shall be used, equally set on each side of the piece of cargo's centre of gravity, and distributed as far away from it as possible in order to minimize any overturning moment.

## 6 Calculation methods

### 6.1 Load factors

**6.1.1** The ultimate loads restraint capability of any tie-down arrangement shall be calculated based on the mass of the piece(s) of cargo to be retained and the following in-flight ultimate load factors, expressed in multiples or fractions of the standard acceleration of gravity (" $g$ " = 9,806 65 m.s<sup>-2</sup>) :

- $L_f$  = load factor in the forward direction of restraint,
- $L_a$  = load factor in the aft direction of restraint,
- $L_y$  = load factor in either side direction of restraint,
- $L_z$  = load factor in the upward direction of restraint.

NOTE A single longitudinal load factor  $L_x = L_f$  is to be used instead of separate fore and aft load factors, whenever there may exist an uncertainty as to the actual direction in which a pallet will be loaded into the aircraft. See [6.1.2](#).

**6.1.2** The load factors shall be those certified for the aircraft type concerned in its manufacturer's Authority approved Weight and Balance Manual, to be contained in the operator's operating instructions. Where they differ according to location or orientation in the aircraft, the load factors certified for the actual location or orientation on board of the piece(s) of cargo concerned may be used. Whenever tie-down is to be performed while the actual location and orientation on board are still undetermined (e.g. advance palletisation), the highest aircraft load factor shall be used in each restraint direction.

**6.1.3** When tie-down is to be performed, e.g. at cargo warehouse, while the aircraft type concerned is still undetermined, or when, exceptionally, no load factors data are readily available on the aircraft type, the following ultimate load factors were determined to be higher than or equal to those applicable for most current international civil transport aircraft, and may be used to perform advance tie-down:

- $L_f = 1,5 g$  (see NOTE 1)
- $L_a = 1,5 g$
- $L_y = 1,5 g$
- $L_z = 3,0 g$  (see NOTE 2)

At loading on aircraft, the actual load factors shall then be checked with the operator or crew, and additional tie-down performed if required.

NOTE 1 The forward ultimate load factor  $L_f$  to be used shall be 9,0 g in a cabin or main deck compartment where there is no certified 9 g barrier net or equivalently stressed bulkhead installed between the load and passenger(s) or crew, in order to cater for emergency landing conditions (see 14 CFR Part 25 and CS-25, paragraphs 25.561 and 25.787). It pertains to operators of such aircraft to provide and implement specific 9,0 g tie-down instructions.

NOTE 2 All load factors to be used require a check by each individual operator in establishing his/her tie-down operating instructions, according to the aircraft fleet he/she operates, particularly due to differences with aircraft size. For example, smaller (narrow body) aircraft may have certified upward load factors  $L_z$  at certain locations up to 4,0 g, while very large capacity aircraft seldom exceed 2,1 g. It pertains to operators of aircraft presenting upward load factors higher than the 3,0 g common industry practice to provide and implement specific tie-down instructions.



## 6.2 Calculation principles

6.2.1 The ultimate restraint capability of each individual strap ( $F$ ) shall be accounted as the lowest of:

- the strap's own rated ultimate load (see ISO 16049-1 for determination and testing), or
- the aircraft or pallet attachment point's rated ultimate load in the direction concerned, or
- the rated strength of the piece of cargo's attachment point, if the strap is attached to cargo at one end (not applicable if the strap passes around or over the piece of cargo and is attached at both ends to aircraft structure or pallet track), or
- the rated ultimate load of any intermediate hardware (e.g. tie-down fitting) used.

6.2.2 The ultimate restraint capability of the total tie-down arrangement is the sum of the three components ( $F_x$  forward or aft,  $F_y$  side, and  $F_z$  upward) of each individual strap's ultimate strength ( $F$ , as defined in 6.2.1) according to the angles ( $\alpha_1$ ,  $\alpha_2$ ,  $\alpha_3$ , as defined in [Figure 1](#)) it forms with the reference directions of restraint.

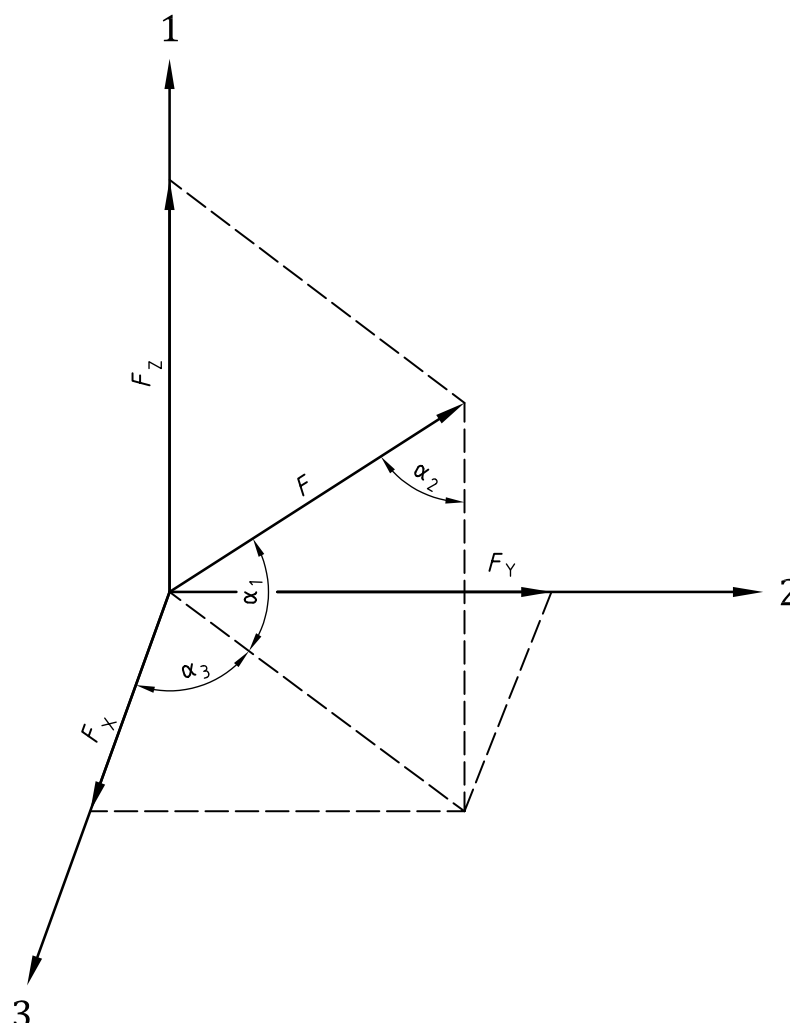

### Key

- |             |                          |
|-------------|--------------------------|
| 1 ( $F_z$ ) | up component             |
| 2 ( $F_y$ ) | side component           |
| 3 ( $F_x$ ) | forward or aft component |

Figure 6 — Load components

**6.2.3** The respective components for any individual strap in each direction of restraint are :

— Forward or aft load:  $F_x = F \times \cos a_1 \times \cos a_3$

— Side load :  $F_y = F \times \cos a_1 \times \sin a_3$

— Up load :  $F_z = F \times \cos a_2$

with  $[F_x^2 + F_y^2 + F_z^2 = F^2]$

**6.2.4** A strap attached between a tie-down fitting and a point of the piece of cargo shall be accounted for once. Where a strap is attached to two fittings on opposite sides of the piece of cargo and passing over or around it, it shall be accounted as two separate straps, using the most critical angles of either end of the strap (see [4.10](#)).

**6.2.5** The ultimate restraint capability provided by the total tie-down arrangement in each of the five directions of restraint is the sum of individual straps components in the direction concerned, and shall be equal to or greater than the applied ultimate load, with :

[Applied ultimate load (UL) = applicable load factor (L) × total mass of cargo to be tied down],

using the ultimate load factors (L) defined for each direction in [6.1](#).

### 6.3 Practical calculation

**6.3.1** Since in field practice it may be almost impossible and prone to error to actually measure the angles for each individual strap and perform in detail the corresponding component forces calculation, each aircraft operator shall establish simplified operating instructions to be used by field staff (e.g. in cargo warehouses or when actually loading aircraft cargo compartments) in order to determine tie-down/lashing arrangements ultimate restraint capability.

**6.3.2** Such operating instructions may consist of either:

- preformatted calculation sheets or charts, or
- graphs or abacus methods, or
- pre-computed tables based on general assumptions to be complied with, or
- any other method deemed appropriate,

avoiding performing detailed calculations for each individual package tie-down, providing the applicable assumptions, if any, are clearly stated and checked, and the results of the method used conform to the calculation principles set in [6.2](#).

The most commonly used method of providing operating instructions for tie-down calculations is described in IATA Airport Handling Manual AHM 311, Securing of load (see Bibliography). For international applications, it is recommended this method be preferentially used in order to ensure uniformity of procedures between operators and handling agencies, and thereby enhance flight safety through uniform training and methods consistency.

**6.3.3** It is essential in order to avoid mistakes that any operating instructions and related charts, graphs, etc., clearly state in bold characters whether the mass figures are expressed in pounds or kilograms (kilograms are preferred for international application in order to further minimize the risk of mistakes).

## 7 Specific requirements

### 7.1 General

There are specific circumstances when the general principles of tie-down as laid out in [Clauses 4, 5 and 6](#), essentially applicable for rectangular shaped packages of a convenient size, may not be sufficient to ensure proper cargo restraint and flight safety. The resulting specific requirements for some of the most common cases are laid out hereafter, but there are many other potential ones. The most common specific cases are overhanging loads, “tall” loads, pipes and other long loads, reels/drums/spools, automobiles, aircraft engines, stacked pallets, marine containers. It remains the operator’s responsibility to interpret those hereafter in the operating instructions, as well as to identify and adequately handle any other specific situations which might render general requirements inappropriate or insufficient.

### 7.2 Risk of cargo slippage

**7.2.1** Whenever the plan-view shape of the piece(s) of cargo to be tied down is significantly smaller than the spacing of available tie-down receptacles, there is a possibility that cargo shifts or slides during flight, within the boundaries defined by tie-down fittings. Tie-down straps used in the direction of possible shifting may not entirely guarantee against such a hazard, due to strap elasticity under load.

**7.2.2** Where such shifting/slippage potential may in some respect jeopardize flight safety (e.g. take a part of the cargo out of the allowable pallet contour and bring it to interfere with the aircraft’s structure, or other damaging consequence), additional steps should be taken to prevent any such damageable occurrence.

**7.2.3** Such preventive steps may consist in:

- providing chocks or equivalent to increase friction in the direction concerned (see note below), or
- blocking with other cargo to fill in the empty horizontal space, or
- providing additional, well tightened, straps in excess of the minimum calculated number for the ultimate load in the direction of restraint concerned, or
- other equivalent method or combination.

**NOTE** In view of the limited static and dynamic friction factors usually achieved between cargo base area and the pallet surface, reliance on unaided friction alone is not acceptable to prevent potentially damageable consequences for the aircraft.

### 7.3 Risk of cargo tilting

**7.3.1** Certain pieces of cargo, particularly “tall” ones, the height of which is significantly more than their width, or those with a high located centre of gravity, present a significant risk of tilting down as a result of horizontal accelerations. A standard tie-down arrangement, particularly where straps are passing around or over the piece of cargo and attached on opposite sides of it, may not guarantee against this hazard, due to straps slippage and elasticity under load.

**7.3.2** Whenever the centre of gravity height of a piece of cargo is significantly higher than its bearing base is wide, additional steps should be taken to prevent the risk of tilting.

**7.3.3** Such preventive steps may consist in:

- blocking with sufficiently strong and high other cargo on all sides liable to tilting. The height of blocking cargo shall be higher than the unstable piece of cargo’s centre of gravity height, or
- providing a diagonally braced supporting stand widening the piece’s bearing width to increase stability prior to tie-down, or

- providing additional, well tightened, straps over the minimum calculated number in the directions of restraint concerned. Such straps shall bear onto the unstable piece higher than its centre of gravity, and should preferably be attached to the piece of cargo itself. If passing around it, particular care shall be taken to ensure they cannot slip down lower than this height (see 4.16), or
- other equivalent method or combination.

## 7.4 Long and narrow items

**7.4.1** Long items with a narrow cross-section, whether or not overhanging from the pallet, may present a tie-down hazard due to the peculiar difficulty in effectively attaching fore and aft restraint straps; e.g. (a) piece(s) of pipe should not be restrained by just inserting the strap's hook(s) into its (their) open end, because this may slip away as a result of straps elasticity and even limited load movement during flight, and cargo can too easily become entirely unrestrained.

**7.4.2** Whenever horizontal straps may not be guaranteed to stay at the end of, for example, a (set of) narrow item(s) of cargo throughout the flight, additional steps should be taken to ensure they stay in place.

**7.4.3** Such preventive steps may consist in:

- providing a rigid restraining screen at each end, built up of planks, metal, or equivalent, or blocking possible movement by other cargo, the height of which shall be higher than the narrow piece(s) concerned, with fore and aft tie-down being applied to the screen, or
- using adequate tie-down accessories at the ends of the narrow piece(s). A common design often known as a "cargo stopper" device is made of straps sewn together with attachment rings and/or hooks.

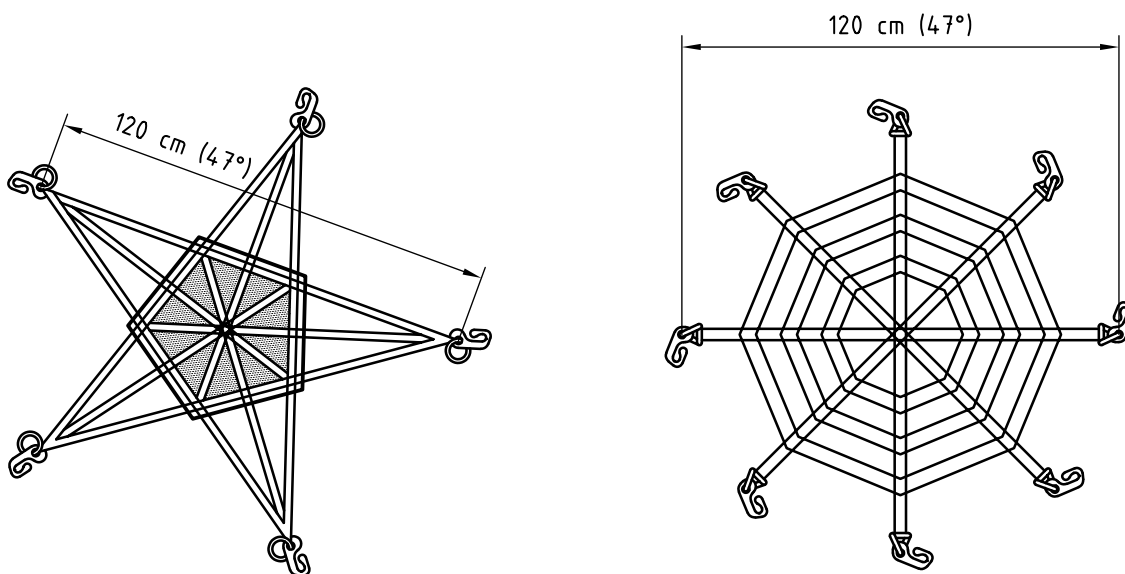

**Figure 7 — Examples of "cargo stopper" tie-down accessories**

**NOTE** Cargo stopper requirements can be found in IATA ULDR SS 60/3 or SAE ARP 6022. See References [6] and [9].

## 8 Operator's responsibilities

**8.1** Flight safety depends on the effectiveness and dependability of cargo securing aboard aircraft. Accordingly, it is essential that operators, as required by Civil Aviation regulations, fully meet their responsibilities as follows.

**8.2** An operator should ensure that procurement of tie-down straps used aboard its aircraft is based on the design criteria and meets the testing, marking and quality control requirements of ISO 16049-1, data records concerning restraint equipment approval be duly kept, and storage durations be controlled so as not to exceed, if applicable, stated expiry dates due to environmental degradation. The above requirements are met when procuring straps approved under TSO/ETSO/CTSO/JTTSO C172.

**8.3** An operator shall develop and distribute to all concerned tie-down operating instructions in accordance with [4.1](#), based on methodology provided by this part of ISO 16049 or equivalent industry recommendations (see Bibliography).

**8.4** An operator shall take all necessary steps to ensure his/her operating instructions are fully understood and applied by a suitably trained competent person or under his/her direct supervision. These steps shall include, but may not be limited to, such actions as:

- a) establishing and implementing initial and recurrent training programmes to ensure the instructions are understood and practiced by a sufficient number of competent persons throughout his/her organization and his/her subcontractors, and
- b) establishing and implementing such procedures as can guarantee an aircraft will not be dispatched with tied-down cargo, unless the tie-down arrangement has been inspected and found satisfactory by a competent person, and
- c) establishing and implementing quality assurance programs applicable to cargo tie-down, meeting the requirements of carriers internal evaluation programs defined by Civil Aviation Authorities (FAA Advisory Circular 120-59 or European EU-OPS 1.035) or, for non-airline subcontractors and handling agencies, ISO 9001 or equivalent pertinent quality assurance programme standards.

## Bibliography

- [1] ISO 9000:2000, *Quality management systems — Fundamentals and vocabulary*
- [2] ISO 9001:2008, *Quality management systems — Requirements*
- [3] IATA Airport Handling Manual AHM 311, *Securing of load*<sup>9)</sup>
- [4] IATA Airport Handling Manual AHM 450, *Standardization of gravity forces against which load must be restrained*<sup>10)</sup>
- [5] IATA ULD Regulations Standard Specification 60/2, *Air cargo restraint straps*<sup>11)</sup>
- [6] IATA ULD Regulations Standard Specification 60/3, *Cargo stopper devices*<sup>12)</sup>
- [7] SAE Aerospace Standard AS5385, *Cargo restraint straps - Design criteria and testing requirements*<sup>13)</sup>
- [8] SAE Aerospace Recommended Practice ARP 5595, *Cargo restraint straps - Utilization guidelines*<sup>14)</sup>
- [9] SAE Aerospace Recommended Practice ARP 6022, *Cargo stopper devices*
- [10] CEN (TC 168) EN 12195-1, *Load restraint assemblies on road vehicles - Safety - Part 1: calculation of lashing forces*<sup>15)</sup>
- [11] Airframe manufacturers Weight and Balance Manuals for each aircraft type

---

9) Corresponds to this part of ISO 16049. AHMs 311 and 450 and Standard Specification 60/2 are part of, respectively, the IATA Airport Handling Manual and Unit Load Devices Technical Manual, which can be obtained from International Air Transport Association, Publications Assistant, 800 Place Victoria, P.O. Box 113, Montréal, Québec H4Z1M1, Canada, or its web site at <http://www.iata.org>.

10) See footnote 9.

11) See footnote 9. In addition, it also corresponds to ISO 16049-1.

12) See footnote 9.

13) Corresponds to ISO 16049-1. SAE AS and ARPs can be obtained from Society of Automotive Engineers, 400, Commonwealth Drive, Warrendale PA 15096-001, U.S.A., or its web site at <http://www.sae.org>.

14) Corresponds to this part of ISO 16049.

15) Only applies to load restraint in surface transport, but contains valid recommendations which it may be useful to consider for air cargo restraint application, or for combined air/surface transportation purposes. Can be obtained from the Comité Européen de Normalisation, Avenue Marnix 17, B-1000 Brussels, Belgium, or any of the European national standardization institutes, members of CEN.









# British Standards Institution (BSI)

BSI is the national body responsible for preparing British Standards and other standards-related publications, information and services.

BSI is incorporated by Royal Charter. British Standards and other standardization products are published by BSI Standards Limited.

## About us

We bring together business, industry, government, consumers, innovators and others to shape their combined experience and expertise into standards-based solutions.

The knowledge embodied in our standards has been carefully assembled in a dependable format and refined through our open consultation process. Organizations of all sizes and across all sectors choose standards to help them achieve their goals.

## Information on standards

We can provide you with the knowledge that your organization needs to succeed. Find out more about British Standards by visiting our website at [bsigroup.com/standards](http://bsigroup.com/standards) or contacting our Customer Services team or Knowledge Centre.

## Buying standards

You can buy and download PDF versions of BSI publications, including British and adopted European and international standards, through our website at [bsigroup.com/shop](http://bsigroup.com/shop), where hard copies can also be purchased.

If you need international and foreign standards from other Standards Development Organizations, hard copies can be ordered from our Customer Services team.

## Subscriptions

Our range of subscription services are designed to make using standards easier for you. For further information on our subscription products go to [bsigroup.com/subscriptions](http://bsigroup.com/subscriptions).

With **British Standards Online (BSOL)** you'll have instant access to over 55,000 British and adopted European and international standards from your desktop. It's available 24/7 and is refreshed daily so you'll always be up to date.

You can keep in touch with standards developments and receive substantial discounts on the purchase price of standards, both in single copy and subscription format, by becoming a **BSI Subscribing Member**.

**PLUS** is an updating service exclusive to BSI Subscribing Members. You will automatically receive the latest hard copy of your standards when they're revised or replaced.

To find out more about becoming a BSI Subscribing Member and the benefits of membership, please visit [bsigroup.com/shop](http://bsigroup.com/shop).

With a **Multi-User Network Licence (MUNL)** you are able to host standards publications on your intranet. Licences can cover as few or as many users as you wish. With updates supplied as soon as they're available, you can be sure your documentation is current. For further information, email [bsmusales@bsigroup.com](mailto:bsmusales@bsigroup.com).

## BSI Group Headquarters

389 Chiswick High Road London W4 4AL UK

## Revisions

Our British Standards and other publications are updated by amendment or revision.

We continually improve the quality of our products and services to benefit your business. If you find an inaccuracy or ambiguity within a British Standard or other BSI publication please inform the Knowledge Centre.

## Copyright

All the data, software and documentation set out in all British Standards and other BSI publications are the property of and copyrighted by BSI, or some person or entity that owns copyright in the information used (such as the international standardization bodies) and has formally licensed such information to BSI for commercial publication and use. Except as permitted under the Copyright, Designs and Patents Act 1988 no extract may be reproduced, stored in a retrieval system or transmitted in any form or by any means – electronic, photocopying, recording or otherwise – without prior written permission from BSI. Details and advice can be obtained from the Copyright & Licensing Department.

## Useful Contacts:

### Customer Services

**Tel:** +44 845 086 9001

**Email (orders):** [orders@bsigroup.com](mailto:orders@bsigroup.com)

**Email (enquiries):** [cservices@bsigroup.com](mailto:cservices@bsigroup.com)

### Subscriptions

**Tel:** +44 845 086 9001

**Email:** [subscriptions@bsigroup.com](mailto:subscriptions@bsigroup.com)

### Knowledge Centre

**Tel:** +44 20 8996 7004

**Email:** [knowledgecentre@bsigroup.com](mailto:knowledgecentre@bsigroup.com)

### Copyright & Licensing

**Tel:** +44 20 8996 7070

**Email:** [copyright@bsigroup.com](mailto:copyright@bsigroup.com)



...making excellence a habit.™