

Direct reduced iron — Determination of the tumble and abrasion indices of hot briquetted iron (HBI)

ICS 73.060.10

National foreword

This British Standard is the UK implementation of ISO 15967:2007.

The UK participation in its preparation was entrusted to Technical Committee ISE/58, Iron ores.

A list of organizations represented on this committee can be obtained on request to its secretary.

This publication does not purport to include all the necessary provisions of a contract. Users are responsible for its correct application.

Compliance with a British Standard cannot confer immunity from legal obligations.

This British Standard was published under the authority of the Standards Policy and Strategy Committee on 30 November 2007

© BSI 2007

ISBN 978 0 580 55308 0

Amendments issued since publication

Amd. No.	Date	Comments

INTERNATIONAL
STANDARD

ISO
15967

Second edition
2007-09-15

**Direct reduced iron — Determination of
the tumble and abrasion indices of hot
briquetted iron (HBI)**

*Minerais de fer prééduits — Détermination des indices de cohésion et
d'abrasion du fer briqueté à chaud*



Reference number
ISO 15967:2007(E)

Contents

Page

Foreword.....	iv
Introduction	v
1 Scope	1
2 Normative references	1
3 Terms and definitions	1
4 Principle	1
5 Sampling, sample preparation and preparation of test portions	1
6 Apparatus	2
7 Procedure	3
8 Expression of results	3
9 Test report	4
10 Verification	4
Annex A (normative) Flowsheet of the procedure for the acceptance of test results	6

Foreword

ISO (the International Organization for Standardization) is a worldwide federation of national standards bodies (ISO member bodies). The work of preparing International Standards is normally carried out through ISO technical committees. Each member body interested in a subject for which a technical committee has been established has the right to be represented on that committee. International organizations, governmental and non-governmental, in liaison with ISO, also take part in the work. ISO collaborates closely with the International Electrotechnical Commission (IEC) on all matters of electrotechnical standardization.

International Standards are drafted in accordance with the rules given in the ISO/IEC Directives, Part 2.

The main task of technical committees is to prepare International Standards. Draft International Standards adopted by the technical committees are circulated to the member bodies for voting. Publication as an International Standard requires approval by at least 75 % of the member bodies casting a vote.

Attention is drawn to the possibility that some of the elements of this document may be the subject of patent rights. ISO shall not be held responsible for identifying any or all such patent rights.

ISO 15967 was prepared by Technical Committee ISO/TC 102, *Iron ore and direct reduced iron*, Subcommittee SC 3, *Physical testing*.

This second edition cancels and replaces the first edition (ISO 15967:2000), which has been revised to homogenise with other physical test standards.

Introduction

The test method in this International Standard has been developed to evaluate the resistance of direct reduced iron in the form of hot briquetted iron (HBI).

The results of this test should be considered in conjunction with other tests used to evaluate the quality of products of direct reduction processes.

This International Standard may be used to provide test results as part of a production quality-control system, as a basis of a contract, or as part of a research project.

The level of degradation measured in this test has been found to be a good indication of HBI resistance during ship loading, transport and handling operations for bulk materials.

Direct reduced iron — Determination of the tumble and abrasion indices of hot briquetted iron (HBI)

CAUTION This International Standard may involve hazardous operations and equipment. This standard does not purport to address all of the safety issues associated with its use. It is the responsibility of the user of this International Standard to establish appropriate safety and health practices and determine the applicability of regulatory limitations prior to its use.

1 Scope

This International Standard specifies a method to provide a relative measure for evaluating the resistance of direct reduced iron to size degradation by impact and abrasion.

This International Standard specifies the determination of the tumble and abrasion indices of hot briquetted iron (HBI).

2 Normative references

The following referenced documents are indispensable for the application of this document. For dated references, only the edition cited applies. For undated references, the latest edition of the referenced document (including any amendments) applies.

ISO 3310-1:2000, *Test sieves — Technical requirements and testing — Part 1: Test sieves of metal wire cloth*

ISO 3310-2:1999, *Test sieves — Technical requirements and testing — Part 2: Test sieves of perforated metal plate*

ISO 10835: 2007, *Direct reduced iron and hot briquetted iron — Sampling and sample preparation*

ISO 11323:2002, *Iron ore and direct reduced iron — Vocabulary*

3 Terms and definitions

For the purposes of this document, the terms and definitions given in ISO 11323 apply.

4 Principle

The test portion is tumbled in a circular drum for a total of 200 revolutions, at 25 r/min. The product material is sieved with test sieves having square openings of 6,30 mm and 500 μm . The tumble index is expressed as the mass percentage of material greater than 6,30 mm, and the abrasion index as the mass percentage of material less than 500 μm .

5 Sampling, sample preparation and preparation of test portions

5.1 Sampling and sample preparation

Sampling of a lot of HBI and sample preparation shall be in accordance with ISO 10835.

A test sample of at least 70 kg, on a dry basis, shall be obtained.

Oven-dry the test sample to constant mass at $105\text{ }^{\circ}\text{C} \pm 5\text{ }^{\circ}\text{C}$ and cool it to room temperature before preparation of the test portions.

NOTE Constant mass is achieved when the difference in mass between two subsequent measurements becomes less than 0,05 % of the initial mass of the test sample.

Sieve the test sample by hand on a 40 mm test sieve to discard any – 40 mm material.

5.2 Preparation of test portions

Spread the test sample on a smooth and flat plate to form a single layer of briquettes, in the shape of a rectangle.

At least 4 test portions, each of approximately 15 kg, shall be prepared by taking, at random, single briquettes and placing them consecutively in 4 piles or containers.

Weigh the test portions and determine whether they meet the mass tolerance of $15\text{ kg} \pm 0,5\text{ kg}$. Single briquette increments shall be added to the test portions from the remaining test sample or removed from the test portions and discarded to make up a weight of $15\text{ kg} \pm 0,5\text{ kg}$. Register the mass of each test portion on its recipient label.

6 Apparatus

6.1 General

The test apparatus shall comprise:

- a) ordinary laboratory equipment, such as an oven, hand tools and safety equipment;
- b) tumble drum and rotation equipment;
- c) test sieves;
- d) a weighing device.

Figure 1 shows an example of the test apparatus.

6.2 Tumble drum, made of steel plate at least 5 mm in thickness, having an internal diameter of 1 000 mm and an internal length of 500 mm. Two equally spaced L-shaped steel lifters 50 mm flat \times 50 mm high \times 5 mm thick and 500 mm long shall be solidly attached longitudinally inside the drum by welding, in such a manner as to prevent accumulation of material between the lifter and drum. The door shall be so constructed as to fit into the drum to form a smooth inner surface. During the test, the door shall be rigidly fastened and sealed to prevent loss of the sample. The drum shall be rotated on stub axles attached to its ends by flanges welded so as to provide smooth inner surfaces. The drum shall be replaced when thickness of the plate is reduced to less than 3 mm in any area. The lifters shall be replaced when the height is reduced to less than 47 mm.

6.3 Drum-rotation equipment, capable of operating on a minimum 1,5 kW power supply to ensure that the drum attains full speed in one revolution, rotates at a constant speed of $25\text{ r/min} \pm 1\text{ r/min}$ and stops within one revolution. The equipment shall be fitted with a revolution counter and with an automatic device for stopping the drum after a predetermined number of revolutions.

6.4 Test sieves, conforming to ISO 3310-1 or ISO 3310-2 and having square mesh apertures of the following nominal sizes: 40,0 mm; 6,30 mm; 500 μm .

6.5 Weighing device, capable of weighing the test sample and test portions to an accuracy of 1 g.

7 Procedure

7.1 Number of determinations for the test

Carry out the test as many times as required by the procedure in Annex A.

7.2 Tumbling

Take, at random, one of the test portions prepared in 5.2, record its mass (m_0) and place it in the tumble drum (6.2). Tightly fasten the door and rotate the drum at $25 \text{ r/min} \pm 1 \text{ r/min}$ for a total of 200 revolutions. Stop the drum and keep the door fastened for at least 2 min before opening, to allow the dust to settle.

DANGER — Tumbling of HBI can be noisy and care must be taken to protect the hearing of the operator.

It is recommended that putty or modelling clay be used to seal the door, to prevent the loss of fines from the drum.

7.3 Sieving

Remove all the material carefully from the drum and hand sieve it on the 6,30 mm and 500 μm sieves (6.4). Determine and record the mass of each fraction retained on 6,30 mm (m_1) and 500 μm (m_2) sieves to the nearest 1 g. Material lost during sieving shall be considered to be part of the – 500 μm fraction.

The difference between the initial mass of the test portion and the total mass of the fractions shall not exceed 1,0 %. If this difference exceeds 1,0 %, the test shall be rejected.

NOTE Equivalent mechanical sieving may be used, provided that preliminary test results give similar results to hand sieving within the permissible tolerance of 2 % absolute.

Care should be taken to ensure that the sieves are not overloaded. An efficient way of achieving this is by including a sieve of aperture size between 6,3 mm and 500 μm (e.g. 2,0 mm or 1,0 mm) and another of aperture size larger than 6,3 mm (e.g. 10,0 mm or 8,0 mm). This will improve sieving efficiency by decreasing the sample mass retained on the 500 μm and the 6,3 mm sieves.

8 Expression of results

8.1 Calculation of the tumble index (T) and abrasion index (A)

The tumble index, T, and the abrasion index, A, expressed as percentages by mass, are calculated from the following formula:

$$T = \frac{m_1}{m_0} \times 100$$

$$A = \frac{m_0 - (m_1 + m_2)}{m_0} \times 100$$

where:

m_0 is the mass, in grams, of the test portion as weighed out and placed in the tumble drum;

m_1 is the mass, in grams, of the + 6,30 mm fraction of the tumbled test portion;

m_2 is the mass, in grams, of the – 6,30 + 500 μm fraction of the tumbled test portion.

Record each result to 2 decimal places.

8.2 Repeatability and acceptance of test results

Follow the procedure in Annex A, for each of the indices, by using the repeatability given in Table 1. The results shall be reported to one decimal place.

Table 1 — Repeatability (r)

Tumble strength	<i>r</i> %, absolute
Tumble index T (+ 6,30 mm)	0,2
Abrasion index A (– 500 μm)	0,12

9 Test report

The test report shall include the following information:

- a) a reference to this International Standard, e.g. ISO 15967:2007;
- b) all details necessary for the identification of the sample;
- c) the name and address of the test laboratory;
- d) the date of the test;
- e) the date of the test report;
- f) the signature of the person responsible for the test;
- g) details of any operation and any test conditions not specified in this International Standard or regarded as optional, as well as any incident which may have had an influence on the results;
- h) the tumble index, T, and the abrasion index, A;
- i) the type of sieve used;
- j) the sieving conditions, e.g. the method of sieving and the sieving time.

10 Verification

Regular checking of the apparatus is essential to ensure test-result reliability. The frequency of checking is a matter for each laboratory to determine.

The conditions of the following items shall be checked:

- sieves;
- weighing device;
- tumble drum;
- drum-rotation equipment.

It is recommended that internal reference material be prepared and used periodically to check test repeatability.

Appropriate records of verification activities shall be maintained.

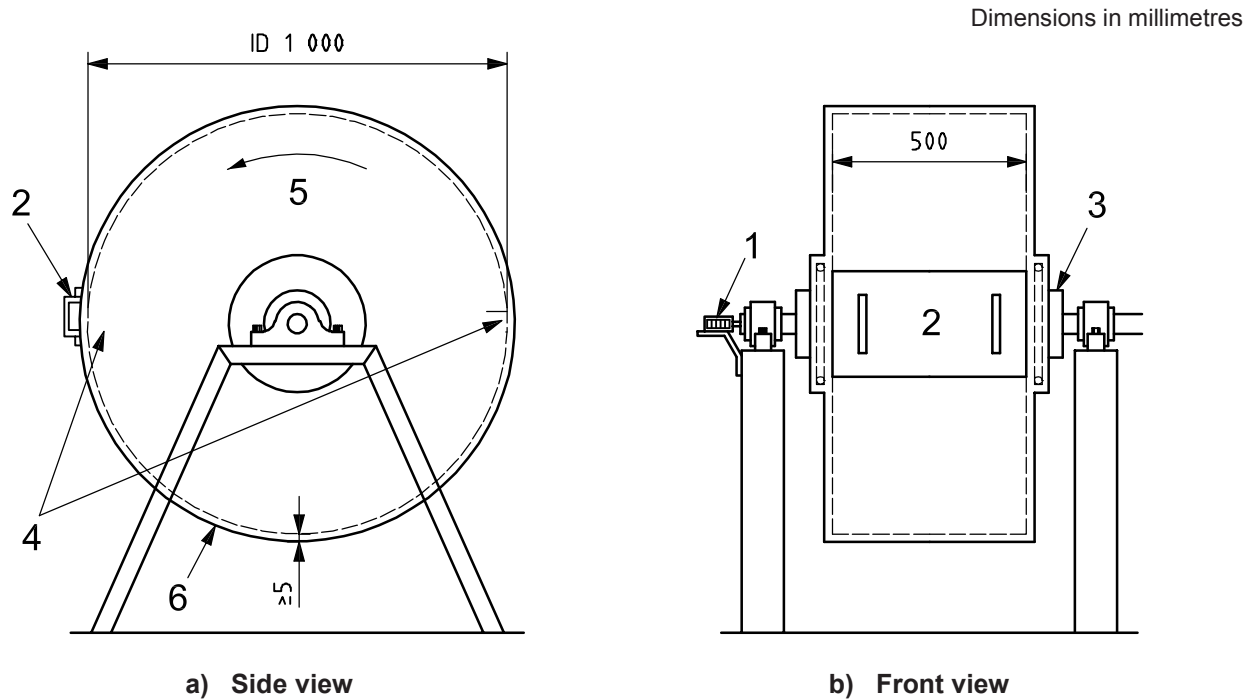

Key

- 1 revolution counter
- 2 door with handle
- 3 stub axle (no through-shaft)
- 4 two lifters (50 × 50 × 5)
- 5 direction of rotation
- 6 plate
- ID internal diameter

Figure 1 — Example of test apparatus (schematic diagram)

Annex A
(normative)

Flowsheet of the procedure for the acceptance of test results

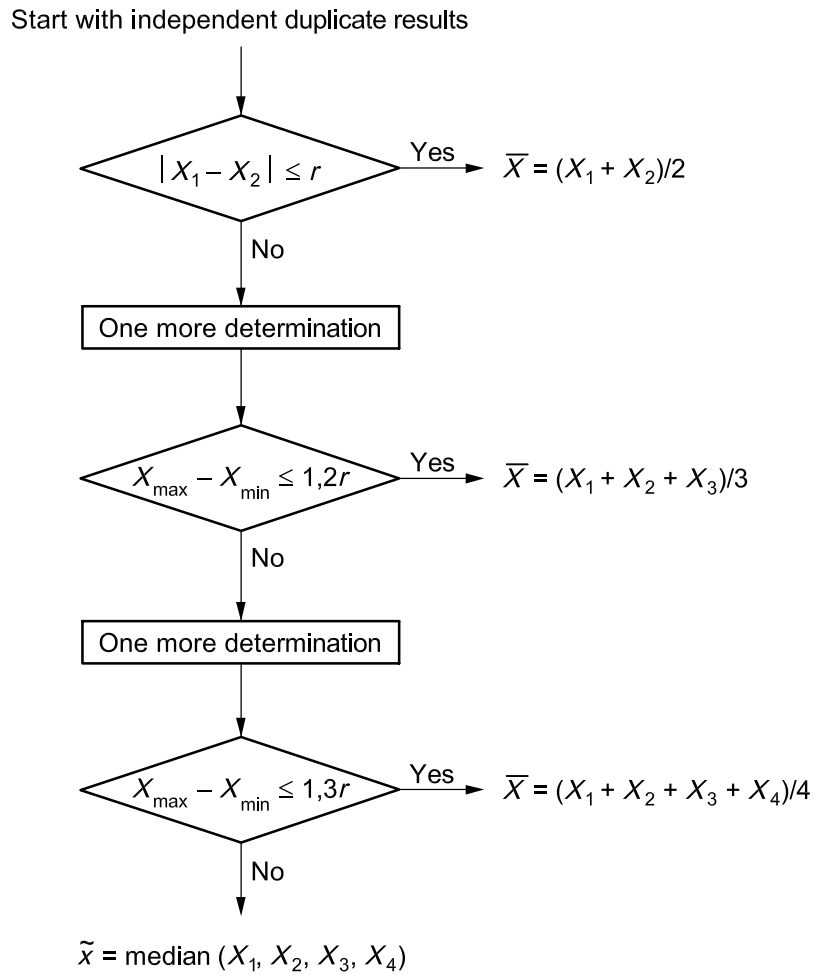

r: see Table 1

BSI — British Standards Institution

BSI is the independent national body responsible for preparing British Standards. It presents the UK view on standards in Europe and at the international level. It is incorporated by Royal Charter.

Revisions

British Standards are updated by amendment or revision. Users of British Standards should make sure that they possess the latest amendments or editions.

It is the constant aim of BSI to improve the quality of our products and services. We would be grateful if anyone finding an inaccuracy or ambiguity while using this British Standard would inform the Secretary of the technical committee responsible, the identity of which can be found on the inside front cover.
Tel: +44 (0)20 8996 9000. Fax: +44 (0)20 8996 7400.

BSI offers members an individual updating service called PLUS which ensures that subscribers automatically receive the latest editions of standards.

Buying standards

Orders for all BSI, international and foreign standards publications should be addressed to Customer Services. Tel: +44 (0)20 8996 9001.
Fax: +44 (0)20 8996 7001. Email: orders@bsi-global.com. Standards are also available from the BSI website at <http://www.bsi-global.com>.

In response to orders for international standards, it is BSI policy to supply the BSI implementation of those that have been published as British Standards, unless otherwise requested.

Information on standards

BSI provides a wide range of information on national, European and international standards through its Library and its Technical Help to Exporters Service. Various BSI electronic information services are also available which give details on all its products and services. Contact the Information Centre.
Tel: +44 (0)20 8996 7111. Fax: +44 (0)20 8996 7048. Email: info@bsi-global.com.

Subscribing members of BSI are kept up to date with standards developments and receive substantial discounts on the purchase price of standards. For details of these and other benefits contact Membership Administration.
Tel: +44 (0)20 8996 7002. Fax: +44 (0)20 8996 7001.
Email: membership@bsi-global.com.

Information regarding online access to British Standards via British Standards Online can be found at <http://www.bsi-global.com/bsonline>.

Further information about BSI is available on the BSI website at <http://www.bsi-global.com>.

Copyright

Copyright subsists in all BSI publications. BSI also holds the copyright, in the UK, of the publications of the international standardization bodies. Except as permitted under the Copyright, Designs and Patents Act 1988 no extract may be reproduced, stored in a retrieval system or transmitted in any form or by any means – electronic, photocopying, recording or otherwise – without prior written permission from BSI.

This does not preclude the free use, in the course of implementing the standard, of necessary details such as symbols, and size, type or grade designations. If these details are to be used for any other purpose than implementation then the prior written permission of BSI must be obtained.

Details and advice can be obtained from the Copyright & Licensing Manager.
Tel: +44 (0)20 8996 7070. Fax: +44 (0)20 8996 7553.
Email: copyright@bsi-global.com.