

BS ISO 15830-3:2013



BSI Standards Publication

# Road vehicles — Design and performance specifications for the WorldSID 50th percentile male side-impact dummy

Part 3: Electronic subsystems

**bsi.**

...making excellence a habit.™

**National foreword**

This British Standard is the UK implementation of ISO 15830-3:2013. It supersedes BS ISO 15830-3:2005 which is withdrawn.

The UK participation in its preparation was entrusted to Technical Committee AUE/7, Automobile occupant restraint systems.

A list of organizations represented on this committee can be obtained on request to its secretary.

This publication does not purport to include all the necessary provisions of a contract. Users are responsible for its correct application.

© The British Standards Institution 2013. Published by BSI Standards Limited 2013

ISBN 978 0 580 76325 0

ICS 43.020

**Compliance with a British Standard cannot confer immunity from legal obligations.**

This British Standard was published under the authority of the Standards Policy and Strategy Committee on 31 July 2013.

**Amendments issued since publication**

Date	Text affected
------	---------------

---

INTERNATIONAL  
STANDARD

**ISO**  
**15830-3**

Second edition  
2013-05-15

---

---

**Road vehicles — Design and  
performance specifications for the  
WorldSID 50th percentile male side-  
impact dummy —**

**Part 3:  
Electronic subsystems**

*Véhicules routiers — Conception et spécifications de performance  
pour le mannequin mondial (WorldSID), 50e percentile homme, de  
choc latéral —*

*Partie 3: Sous-systèmes électroniques*



Reference number  
ISO 15830-3:2013(E)

© ISO 2013



**COPYRIGHT PROTECTED DOCUMENT**

© ISO 2013

All rights reserved. Unless otherwise specified, no part of this publication may be reproduced or utilized otherwise in any form or by any means, electronic or mechanical, including photocopying, or posting on the internet or an intranet, without prior written permission. Permission can be requested from either ISO at the address below or ISO's member body in the country of the requester.

ISO copyright office  
Case postale 56 • CH-1211 Geneva 20  
Tel. + 41 22 749 01 11  
Fax + 41 22 749 09 47  
E-mail [copyright@iso.org](mailto:copyright@iso.org)  
Web [www.iso.org](http://www.iso.org)

Published in Switzerland

# Contents

Page

<b>Foreword</b> .....	<b>iv</b>
<b>Introduction</b> .....	<b>v</b>
<b>1 Scope</b> .....	<b>1</b>
<b>2 Normative references</b> .....	<b>1</b>
<b>3 Terms and definitions</b> .....	<b>1</b>
<b>4 Electrical subsystems requirements</b> .....	<b>1</b>
4.1 Permissible sensors.....	1
4.2 Permissible internal data acquisition system (DAS).....	7
<b>5 Methods</b> .....	<b>8</b>
5.1 Calculation of IR-TRACC distances from the IR-TRACC voltage outputs.....	8
<b>Annex A (normative) Load cell characteristics</b> .....	<b>9</b>
<b>Annex B (informative) Conventions for exemplar permissible load cells and angular displacement sensors</b> .....	<b>14</b>
<b>Annex C (informative) Conventions for permissible accelerometers</b> .....	<b>21</b>
<b>Annex D (normative) Information regarding sensor output polarities</b> .....	<b>23</b>
<b>Bibliography</b> .....	<b>41</b>

## Foreword

ISO (the International Organization for Standardization) is a worldwide federation of national standards bodies (ISO member bodies). The work of preparing International Standards is normally carried out through ISO technical committees. Each member body interested in a subject for which a technical committee has been established has the right to be represented on that committee. International organizations, governmental and non-governmental, in liaison with ISO, also take part in the work. ISO collaborates closely with the International Electrotechnical Commission (IEC) on all matters of electrotechnical standardization.

The procedures used to develop this document and those intended for its further maintenance are described in the ISO/IEC Directives, Part 1. In particular the different approval criteria needed for the different types of ISO documents should be noted. This document was drafted in accordance with the editorial rules of the ISO/IEC Directives, Part 2. [www.iso.org/directives](http://www.iso.org/directives)

Attention is drawn to the possibility that some of the elements of this document may be the subject of patent rights. ISO shall not be held responsible for identifying any or all such patent rights. Details of any patent rights identified during the development of the document will be in the Introduction and/or on the ISO list of patent declarations received. [www.iso.org/patents](http://www.iso.org/patents)

Any trade name used in this document is information given for the convenience of users and does not constitute an endorsement.

The committee responsible for this document is ISO/TC 22, *Road vehicles*, Subcommittee SC 12, *Passive safety crash protection systems*.

This second edition cancels and replaces the first edition (ISO 15830-3:2005) which has been technically revised. Technical amendments have been incorporated throughout all four parts, resulting from extensive experience with the International Standard and design changes.

ISO 15830 consists of the following parts, under the general title *Road vehicles — Design and performance specifications for the WorldSID 50th percentile male side-impact dummy*:

- *Part 1: Terminology and rationale*
- *Part 2: Mechanical subsystems*
- *Part 3: Electronic subsystems*
- *Part 4: User's manual*

## Introduction

This second edition of ISO 15830 has been prepared on the basis of the existing design, specifications, and performance of the WorldSID 50th percentile adult male side-impact dummy. The purpose of the ISO 15830 series is to document the design and specifications of this side-impact dummy in a form suitable and intended for worldwide regulatory use.

In 1997, ISO/TC22/SC12 initiated the WorldSID 50th percentile adult male dummy development, with the aims of defining a global-consensus side-impact dummy, having a wider range of humanlike anthropometry, biofidelity, and injury-monitoring capabilities, suitable for regulatory use. Participating in the development were research institutes, dummy and instrumentation manufacturers, governments, and vehicle manufacturers from around the world.

With regards to potential regulatory, consumer information, or research and development use of ISO 15830, users will need to identify which of the permissive (i.e. optional) sensors and other elements defined in this part of ISO 15830 will be required for their tests.

WorldSID drawings in electronic format are being made available. Details are given in ISO 15830-2:2013, [Annex B](#).

In order to apply ISO 15830 properly, it is important that all four parts be used together.





# Road vehicles — Design and performance specifications for the WorldSID 50th percentile male side-impact dummy —

## Part 3: Electronic subsystems

### 1 Scope

This part of ISO 15830 specifies requirements for electronic components of the WorldSID 50th percentile side-impact dummy, a standardized anthropomorphic dummy for side-impact testing of road vehicles. It is applicable to impact tests involving

- passenger vehicles of category M<sub>1</sub> and goods vehicles of category N<sub>1</sub>,
- impacts to the side of the vehicle structure,
- impact tests involving the use of an anthropometric dummy as a human surrogate for the purpose of evaluating compliance with vehicle safety standards.

### 2 Normative references

The following documents, in whole or in part, are normatively referenced in this document and are indispensable for its application. For dated references, only the edition cited applies. For undated references, the latest edition of the referenced document (including any amendments) applies.

ISO 6487, *Road vehicles — Measurement techniques in impact tests — Instrumentation*

ISO 15830-1, *Design and performance specifications for the WorldSID 50th percentile male side-impact dummy — Part 1: Terminology and rationale*

ISO 15830-2:2013, *Design and performance specifications for the WorldSID 50th percentile male side-impact dummy — Part 2: Mechanical subsystems*

SAE J2570:2001, *Performance specifications for anthropomorphic test device transducers*

SAE J1733, *Sign convention for vehicle crash testing*

### 3 Terms and definitions

For the purposes of this document, the terms and definitions given in ISO 15830-1 apply.

### 4 Electrical subsystems requirements

#### 4.1 Permissible sensors

##### 4.1.1 General

NOTE All sensors are specified as “permissible” (i.e. optional) because the decision to use or not to use a given sensor is to be left to the individual relevant regulatory authorities, consumer information organisations, and research or test laboratories. In this way, a given regulation (or laboratory protocol) can indicate which of the permissible sensors described in this part of ISO 15830 must be used in a given test. It should also be noted that different connector configurations may be found in different WorldSID assemblies.

The following sensors may be installed in the dummy. If installed, they shall comply with the specifications given in [Table 1](#). If these sensors are not installed, then structural or mass replacements shall be installed in the dummy.

#### 4.1.2 Locations and specifications

**Table 1 — Permissible WorldSID sensor locations and specifications**

Body region	Sensor	Sensor specification	Mounting specification	Maximum number of channels
Head	Linear accelerometer	<a href="#">4.1.3.2</a>	ISO 15830-2:2013, 4.1	3
Head	Rotational accelerometer	<a href="#">4.1.3.3</a>	ISO 15830-2:2013, 4.1	3
Head	Tilt sensor (about x and y axes)	<a href="#">4.1.3.4</a>	ISO 15830-2:2013, 4.1	2
Head	Upper neck load cell	<a href="#">4.1.3.5</a>	ISO 15830-2:2013, 4.1	6
Neck	Lower neck load cell	<a href="#">4.1.3.5</a>	ISO 15830-2:2013, 4.2	6
Neck	T1 linear accelerometer	<a href="#">4.1.3.2</a>	ISO 15830-2:2013, 4.2	3
Shoulder	Rib linear accelerometer	<a href="#">4.1.3.2</a>	ISO 15830-2:2013, 4.3	3
Shoulder	IR-TRACC	<a href="#">4.1.3.6</a>	ISO 15830-2:2013, 4.3	1
Shoulder	Load cell ( $F_x, F_y, F_z$ )	<a href="#">4.1.3.7</a>	ISO 15830-2:2013, 4.3	3
Full arm	Upper arm load cell	<a href="#">4.1.3.8</a>	ISO 15830-2:2013, 4.4	6
Full arm	Lower arm load cell	<a href="#">4.1.3.8</a>	ISO 15830-2:2013, 4.4	6
Full arm	Elbow load cell ( $M_x, M_y$ )	<a href="#">4.1.3.9</a>	ISO 15830-2:2013, 4.4	2
Full arm	Elbow angular displacement	<a href="#">4.1.3.10</a>	ISO 15830-2:2013, 4.4	1
Full arm	Elbow linear accelerometer	<a href="#">4.1.3.2</a>	ISO 15830-2:2013, 4.4	3
Full arm	Wrist linear accelerometer	<a href="#">4.1.3.2</a>	ISO 15830-2:2013, 4.4	3
Thorax	Upper rib linear accelerometer	<a href="#">4.1.3.2</a>	ISO 15830-2:2013, 4.3	3
Thorax	Middle rib linear accelerometer	<a href="#">4.1.3.2</a>	ISO 15830-2:2013, 4.3	3
Thorax	Lower rib linear accelerometer	<a href="#">4.1.3.2</a>	ISO 15830-2:2013, 4.3	3
Thorax	Upper rib IR-TRACC	<a href="#">4.1.3.6</a>	ISO 15830-2:2013, 4.3	1
Thorax	Middle rib IR-TRACC	<a href="#">4.1.3.6</a>	ISO 15830-2:2013, 4.3	1
Thorax	Lower rib IR-TRACC	<a href="#">4.1.3.6</a>	ISO 15830-2:2013, 4.3	1
Spine	T4 linear accelerometer	<a href="#">4.1.3.2</a>	ISO 15830-2:2013, 4.3	3
Spine	T12 linear accelerometer	<a href="#">4.1.3.2</a>	ISO 15830-2:2013, 4.3	3
Spine	Rotational accelerometer (about x- and z-axes)	<a href="#">4.1.3.3</a>	ISO 15830-2:2013, 4.3	2
Spine	Tilt sensor (about x- and y-axes)	<a href="#">4.1.3.4</a>	ISO 15830-2:2013, 4.3	2
Abdomen	Upper rib linear accelerometer	<a href="#">4.1.3.2</a>	ISO 15830-2:2013, 4.3	3
Abdomen	Lower rib linear accelerometer	<a href="#">4.1.3.2</a>	ISO 15830-2:2013, 4.3	3
Abdomen	Upper rib IR-TRACC	<a href="#">4.1.3.6</a>	ISO 15830-2:2013, 4.3	1
Abdomen	Lower rib IR-TRACC	<a href="#">4.1.3.6</a>	ISO 15830-2:2013, 4.3	1
Lumbar spine/ pelvis	Lumbar load cell	<a href="#">4.1.3.11</a>	ISO 15830-2:2013, 4.6	6
Lumbar spine/ pelvis	Pelvis linear accelerometer	<a href="#">4.1.3.2</a>	ISO 15830-2:2013, 4.6	3
Lumbar spine/ pelvis	Pubic load cell ( $F_y$ )	<a href="#">4.1.3.12</a>	ISO 15830-2:2013, 4.6	1

Table 1 (continued)

Body region	Sensor	Sensor specification	Mounting specification	Maximum number of channels
Lumbar spine/pelvis	Sacro-iliac load cell	<a href="#">4.1.3.13</a>	ISO 15830-2:2013, 4.6	12
Lumbar spine/pelvis	Tilt sensor (about $x$ - and $y$ -axes)	<a href="#">4.1.3.3</a>	ISO 15830-2:2013, 4.6	2
Upper leg	Femoral neck load cell ( $F_x, F_y, F_z$ )	<a href="#">4.1.3.14</a>	ISO 15830-2:2013, 4.7	3
Upper leg	Mid femur load cell	<a href="#">4.1.3.14</a>	ISO 15830-2:2013, 4.7	6
Upper leg	Knee lateral outboard contact force load cell	<a href="#">4.1.3.16</a>	ISO 15830-2:2013, 4.7	1
Upper leg	Knee lateral inboard contact force load cell	<a href="#">4.1.3.16</a>	ISO 15830-2:2013, 4.7	1
Upper leg	Knee angular displacement	<a href="#">4.1.3.17</a>	ISO 15830-2:2013, 4.7	1
Lower leg	Upper tibia load cell	<a href="#">4.1.3.15</a>	ISO 15830-2:2013, 4.8	6
Lower leg	Lower tibia load cell	<a href="#">4.1.3.15</a>	ISO 15830-2:2013, 4.8	6
Lower leg	Ankle angular displacement	<a href="#">4.1.3.18</a>	ISO 15830-2:2013, 4.8	3
Spine box	Air temperature sensor	<a href="#">4.1.3.19</a>	ISO 15830-2:2013, 4.3	1

### 4.1.3 Sensor specifications and mass

#### 4.1.3.1 General

All load cells, accelerometers, and angular displacement transducers shall comply with SAE J2570, and load cells shall comply with the capacities and sign conventions in [Annex A](#).

Sensor sign convention shall comply with SAE J1733 and any deviations shall be noted.

#### 4.1.3.2 Tri-axial linear accelerometers

- If measured, tri-axial linear accelerations shall be measured using Endevco accelerometer, model 7268C-2000M1<sup>1)</sup>.
- Tri-axial linear accelerometer assemblies shall have a mass of  $8 \text{ g} \pm 1 \text{ g}$  (not including cable).

#### 4.1.3.3 Rotational accelerometers

- If measured, rotational accelerations shall be measured using Endevco accelerometer, model 7302BM4<sup>2)</sup>.
- Rotational accelerometers shall have a mass of  $35 \text{ g} \pm 4 \text{ g}$  (not including cable).

#### 4.1.3.4 Tilt-angle sensors

##### 4.1.3.4.1 Head tilt sensor

1) Accelerometer model 7268C-2000M1 is a product supplied by Endevco Corp., San Juan Capistrano, California, USA. This information is given for the convenience of users of this part of ISO 15830 and does not constitute an endorsement by ISO of the product named. Alternative products may be used if they can be shown to lead to the same results.

2) Accelerometer model 7302BM4 is a product supplied by Endevco Corp., San Juan Capistrano, California, USA. This information is given for the convenience of users of this part of ISO 15830 and does not constitute an endorsement by ISO of the product named. Alternative products may be used if they can be shown to lead to the same results.

- If measured, head tilt angles shall be measured using either IES tilt sensor, model/1401 AT<sup>3)</sup>, or MSC Automotive GmbH tilt sensor, model 260D/GP-X<sup>4)</sup>.
- Head tilt sensors shall have a mass of less than 25 g (not including cable).

#### 4.1.3.4.2 Thorax and pelvis tilt sensor

- If measured, thorax and pelvis tilt angles shall be measured using either IES tilt sensor, model IES/1401 T<sup>5)</sup>, or MSC Automotive GmbH tilt sensor, model 260D/GP-X<sup>6)</sup>.
- Thorax and pelvis tilt sensors shall have a mass of less than 25 g (not including cable).

#### 4.1.3.5 Universal neck load cell

- If measured, upper and lower neck forces and moments shall be measured using Humanetics (formerly Denton) load cell, model W50-71000<sup>7)</sup>.
- Upper and lower neck load cells shall have a mass of 346 g ± 20 g (not including attachment bolts or plug) or 361 g ± 25 g (including mating plug and 450 mm of cable).

#### 4.1.3.6 IR-TRACC for shoulder, chest and abdomen rib deflection

- If measured, rib deflections shall be measured using Humanetics (formerly FTSS) Infra-red Telescoping Rod for the Assessment of Chest Deflection (IR-TRACC), model IF-363<sup>8)</sup>.
- IR-TRACCs shall have a mass of 117 g ± 15 g (including the connector and 300 mm of cable).

Calculation of IR-TRACC displacements shall be performed as described in [5.1](#).

#### 4.1.3.7 Shoulder load cell

- If measured, shoulder forces shall be measured using Humanetics (formerly Denton) load cell, model W50-71090<sup>9)</sup>.

3) Head tilt sensor model IES/1401 AT is a product supplied by Humanetics (formerly Robert A. Denton, Inc.), Plymouth, Michigan, USA. This information is given for the convenience of users of this part of ISO 15830 and does not constitute an endorsement by ISO of the product named. Alternative products may be used if they can be shown to lead to the same results.

4) Tilt sensor model 260D/GP-X is a product supplied by MSC Automotive GmbH. This information is given for the convenience of users of this part of ISO 15830 and does not constitute an endorsement by ISO of the product named. Alternative products may be used if they can be shown to lead to the same results.

5) Thorax and pelvis tilt sensor model IES/1401 T is a product supplied by Humanetics (formerly Robert A. Denton, Inc.), Plymouth, Michigan, USA. This information is given for the convenience of users of this part of ISO 15830 and does not constitute an endorsement by ISO of the product named. Alternative products may be used if they can be shown to lead to the same results.

6) Tilt sensor model 260D/GP-X is a product supplied by MSC Automotive GmbH. This information is given for the convenience of users of this part of ISO 15830 and does not constitute an endorsement by ISO of the product named. Alternative products may be used if they can be shown to lead to the same results.

7) Load cell model W50-71000 (see ISO 15830-2:2013, Annex C) is a product supplied by Humanetics (formerly Robert A. Denton, Inc.), Plymouth, Michigan, USA. This information is given for the convenience of users of this part of ISO 15830 and does not constitute an endorsement by ISO of the product named. Alternative products may be used if they can be shown to lead to the same results.

8) IR-TRACC model IF-363 (see ISO 15830-2:2013, Annex C) is a product supplied by Humanetics (formerly First Technology Safety Systems, Inc.), Plymouth, Michigan, USA. This information is given for the convenience of users of this part of ISO 15830 and does not constitute an endorsement by ISO of the product named. Alternative products may be used if they can be shown to lead to the same results.

9) Load cell model W50-71090 (see ISO 15830-2:2013, Annex C) is a product supplied by Humanetics (formerly Robert A. Denton, Inc.), Plymouth, USA. This information is given for the convenience of users of this part of ISO 15830 and does not constitute an endorsement by ISO of the product named. Alternative products may be

- Shoulder load cell shall have a mass of  $176 \text{ g} \pm 13 \text{ g}$  (not including cable and mating connector).

#### 4.1.3.8 Arm load cell

- If measured, upper and lower arm forces and moments shall be measured using Humanetics (formerly Denton) load cell, model W50-71070<sup>10</sup>.
- Upper and lower arm load cells shall have a mass of  $385 \text{ g} \pm 30 \text{ g}$  (not including cable and mating connector).

#### 4.1.3.9 Elbow load cell

- If measured, elbow moments shall be measured using Humanetics (formerly Denton) load cell, model W50-71060<sup>11</sup>.
- Elbow load cell shall have a mass of  $300 \text{ g} \pm 22 \text{ g}$  (not including cable and mating connector).

#### 4.1.3.10 Elbow rotational potentiometer

- If measured, elbow angular displacement shall be measured using Humanetics (formerly Denton) potentiometer, model W50-61027<sup>12</sup>.
- Elbow potentiometer shall have a mass of  $15 \text{ g} \pm 2 \text{ g}$  (not including cable and mating connector).

#### 4.1.3.11 Lumbar load cell

- If measured, lumbar forces and moments shall be measured using Humanetics (formerly Denton) load cell, model W50-71120<sup>13</sup>.
- Lumbar load cell shall have a mass of  $473 \text{ g} \pm 35 \text{ g}$  (not including cable and mating connector).

#### 4.1.3.12 Pubic load cell

- If measured, pubic forces and moments shall be measured using Humanetics (formerly Denton) load cell, model W50-71051<sup>14</sup>.
- Pubic load cell shall have a mass of  $145 \text{ g} \pm 10 \text{ g}$  (not including cable and mating connector).

used if they can be shown to lead to the same results.

10) Load cell model W50-71070 (see ISO 15830-2:2013, Annex C) is a product supplied by Humanetics (formerly Robert A. Denton, Inc.), Plymouth, Michigan, USA. This information is given for the convenience of users of this part of ISO 15830 and does not constitute an endorsement by ISO of the product named. Alternative products may be used if they can be shown to lead to the same results.

11) Load cell model W50-71060 (see ISO 15830-2:2013, Annex C) is a product supplied by Humanetics (formerly Robert A. Denton, Inc.), Plymouth, Michigan, USA. This information is given for the convenience of users of this part of ISO 15830 and does not constitute an endorsement by ISO of the product named. Alternative products may be used if they can be shown to lead to the same results.

12) Potentiometer model W50-61027 (see ISO 15830-2:2013, Annex C) is a product supplied by Humanetics (formerly Robert A. Denton, Inc.), Plymouth, Michigan, USA. This information is given for the convenience of users of this part of ISO 15830 and does not constitute an endorsement by ISO of the product named. Alternative products may be used if they can be shown to lead to the same results.

13) Load cell model W50-71120 (see ISO 15830-2:2013, Annex C) is a product supplied by Humanetics (formerly Robert A. Denton, Inc.), Plymouth, Michigan, USA. This information is given for the convenience of users of this part of ISO 15830 and does not constitute an endorsement by ISO of the product named. Alternative products may be used if they can be shown to lead to the same results.

14) Load cell model W50-71051 (see ISO 15830-2:2013, Annex C) is a product supplied by Humanetics (formerly Robert A. Denton, Inc.), Plymouth, Michigan, USA. This information is given for the convenience of users of this part of ISO 15830 and does not constitute an endorsement by ISO of the product named. Alternative products may be used if they can be shown to lead to the same results.

#### 4.1.3.13 Sacro-iliac load cell

- If measured, sacro-iliac forces and moments shall be measured using Humanetics (formerly Denton) load cell, model W50-71130<sup>15</sup>.
- Sacro-iliac load cell shall have a mass of  $1\,062\text{ g} \pm 75\text{ g}$  (not including cable and mating connector).

#### 4.1.3.14 Femoral neck load cell

- If measured, femoral neck forces shall be measured using Humanetics (formerly Denton) load cell, model W50-71080<sup>16</sup>.
- Femoral neck load cell shall have a mass of  $240\text{ g} \pm 18\text{ g}$  (not including cable and mating connector).

#### 4.1.3.15 Mid-femur and leg load cell

- If measured, upper and lower leg forces and moments shall be measured using Humanetics (formerly Denton) load cell, model W50-71010<sup>17</sup>.
- Upper and lower leg load cell shall have a mass of  $470\text{ g} \pm 36\text{ g}$  (not including cable and mating connector).

#### 4.1.3.16 Knee contact load cell

- If measured, knee contact lateral force shall be measured using Humanetics (formerly Denton) load cell, model W50-71020<sup>18</sup>.
- Knee contact load cell shall have a mass of  $77\text{ g} \pm 6\text{ g}$  (not including cable and mating connector).

#### 4.1.3.17 Knee rotational potentiometer

- If measured, knee angular displacement shall be measured using Humanetics (formerly Denton) potentiometer, model W50-61027<sup>19</sup>.
- Knee potentiometer shall have a mass of  $15\text{ g} \pm 2\text{ g}$  (not including cable).

#### 4.1.3.18 Ankle rotational potentiometer

---

15) Load cell model W50-71130 (see ISO 15830-2:2013, Annex C) is a product supplied by Humanetics (formerly Robert A. Denton, Inc.), Plymouth, Michigan, USA. This information is given for the convenience of users of this part of ISO 15830 and does not constitute an endorsement by ISO of the product named. Alternative products may be used if they can be shown to lead to the same results.

16) Load cell model W50-71080 (see ISO 15830-2:2013, Annex C) is a product supplied by Humanetics (formerly Robert A. Denton, Inc.), Plymouth, Michigan, USA. This information is given for the convenience of users of this part of ISO 15830 and does not constitute an endorsement by ISO of the product named. Alternative products may be used if they can be shown to lead to the same results.

17) Load cell model W50-71010 (see ISO 15830-2:2013, Annex C) is a product supplied by Humanetics (formerly Robert A. Denton, Inc.), Plymouth, Michigan, USA. This information is given for the convenience of users of this part of ISO 15830 and does not constitute an endorsement by ISO of the product named. Alternative products may be used if they can be shown to lead to the same results.

18) Load cell model W50-71020 (see ISO 15830-2:2013, Annex C) is a product supplied by Humanetics (formerly Robert A. Denton, Inc.), Plymouth, Michigan, USA. This information is given for the convenience of users of this part of ISO 15830 and does not constitute an endorsement by ISO of the product named. Alternative products may be used if they can be shown to lead to the same results.

19) Potentiometer model W50-61027 (see ISO 15830-2:2013, Annex C) is a product supplied by Humanetics (formerly Robert A. Denton, Inc.), Plymouth, Michigan, USA. This information is given for the convenience of users of this part of ISO 15830 and does not constitute an endorsement by ISO of the product named. Alternative products may be used if they can be shown to lead to the same results.

- If measured, ankle  $x$ ,  $y$ ,  $z$  angular displacements shall be measured using Humanetics (formerly Denton) potentiometer, models W50-54012, W50-54052, and W50-54051, respectively<sup>20)</sup>.
- Ankle potentiometers shall have a mass of  $7 \text{ g} \pm 5 \text{ g}$  (not including cable).

#### 4.1.3.19 Temperature sensor

- If measured, thoracic cavity temperature shall be measured using a Dallas Semiconductor temperature sensor, model DS192H/Z<sup>21)</sup>.
- Temperature sensor assembly shall have a mass of  $21 \text{ g} \pm 5 \text{ g}$  (not including cable).

## 4.2 Permissible internal data acquisition system (DAS)

### 4.2.1 General

The following DAS may be installed in the dummy. If installed, it shall comply with the following specifications. If the DAS is not installed, then the DAS mass replacements shall be installed in the dummy.

### 4.2.2 DAS characteristics

- If installed, the DTS WorldSID G5 DAS<sup>22)</sup> shall be mounted in accordance with the drawings given in ISO 15830-2:2013.
- The size, location, and mounting of the DAS shall not interfere with dummy motions.
- DAS electronic specifications shall comply with SAE J211 or ISO 6487.

### 4.2.3 DAS mass and mass distribution

- The combined mass of in-dummy DAS components or DAS mass replacements, excluding sensors and sensor cables, shall be  $2,20 \text{ kg} \pm 0,5 \text{ kg}$ .
- DAS mass shall be distributed as given in [Table 2](#).

---

20) Potentiometer, models W50-54012, W50-54052, and W50-54051 (see ISO 15830-2:2013, Annex C) are products supplied by Humanetics (formerly Robert A. Denton, Inc.), Plymouth, Michigan, USA. This information is given for the convenience of users of this International Standard and does not constitute an endorsement by ISO of the product named. Alternative products may be used if they can be shown to lead to the same results.

21) Temperature sensor, model DS192H/Z is a product supplied by Dallas Semiconductor. This information is given for the convenience of users of this International Standard and does not constitute an endorsement by ISO of the product named. Alternative products may be used if they can be shown to lead to the same results.

22) The WorldSID G5 DAS is a product supplied by Diversified Technical Systems, Inc. (DTS), Seal Beach, California, USA. This information is given for the convenience of users of this International Standard and does not constitute an endorsement by ISO of the product named. Alternative products may be used if they can be shown to lead to the same results.

Table 2 — DAS mass distribution

Body segment	DAS mass (g) <sup>a</sup>
Attached to and inside spine box	1 560 ± 350
Left femur	287 ± 60
Right femur	287 ± 60
Thorax cabling	75 ± 30

<sup>a</sup> Table 2 does not include the mass of the DAS for the full arm, which, if used, would be placed in the dummy external suit pocket. Neither a mass replacement nor a structural replacement is required for this special permissible DAS unit.

## 5 Methods

### 5.1 Calculation of IR-TRACC distances from the IR-TRACC voltage outputs

If the permissible IR-TRACC is installed, deflections based on IR-TRACC voltage measurements shall be calculated as follows:

- 1) Record the voltage signal from the IR-TRACC. Do not remove the zero offset.
- 2) Calculate

$$V_L = \left[ \text{abs} \left( \frac{V_m}{1000} \right) \right]^{-\left( \frac{75}{175} \right)} \quad (1)$$

where

$V_L$  is the equivalent linear output/input voltage (V);

$V_m$  is voltage from the IR-TRACC (mV).

- 3) Remove the zero offset from  $V_L$ ,

$$V_{LO} = V_L - V_O \quad (2)$$

where

$V_{LO}$  is the equivalent linear output/input voltage with zero offset removed (volts);

$V_{LO}$  is 0 when deflection is 0;

$V_O$  is the calculated  $V_L$  when deflection is 0.

- 4) Calculate

$$D = V_{LO} \times C \quad (3)$$

where

$D$  is the deflection (mm);

$C$  is the scale factor (mm/V).



## Annex A (normative)

### Load cell characteristics

#### A.1 Load cell capacities

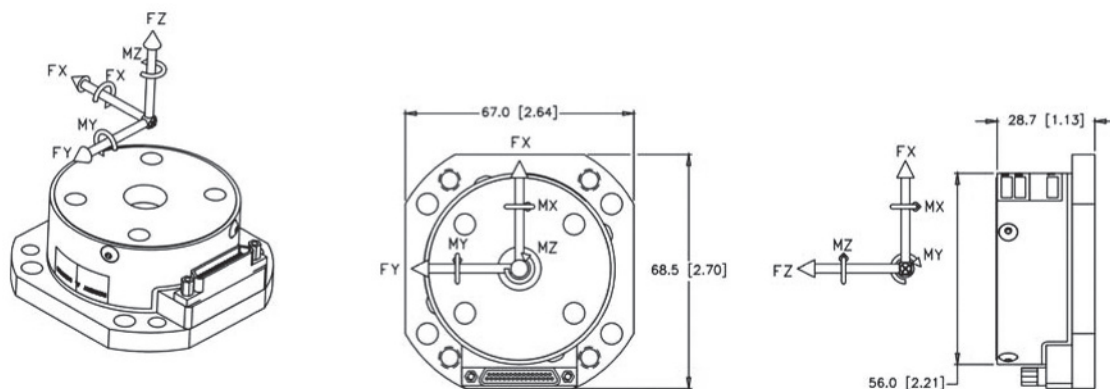
The WorldSID load cells shall comply with the capacities given in [Table A.1](#).

**Table A.1 — WorldSID load cell capacities**

Description	Load cell channel capacities						Part number
	$F_x$ (kN)	$F_y$ (kN)	$F_z$ (kN)	$M_x$ (Nm)	$M_y$ (Nm)	$M_z$ (Nm)	
Universal neck load cell	10,0	10,0	12,0	300	300	200	W50-71000
Universal leg load cell	15,0	15,0	15,0	350	350	300	W50-71010
Universal arm load cell	9,0	9,0	13,5	225	225	170	W50-71070
Knee contact load cell	-	20,0	-	-	-	-	W50-71020
Elbow load cell	-	-	-	225	225	-	W50-71060
Pubic symphysis load cell	-	12,0	-	-	-	-	W50-71051
Femoral neck load cell	10,0	25,0	10,0	-	-	-	W50-71080
Sacro-iliac load cell	6,0	12,0	6,0	800	400	400	W50-71130
Shoulder load cell	5,0	10,0	5,0	-	-	-	W50-71090
Lumbar spine load cell	10,0	10,0	12,0	300	300	200	W50-71120

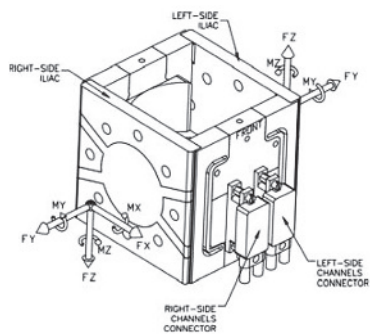
#### A.2 Load cell sign conventions

The WorldSID load cells are shown in [Figures A.1](#) to [A.11](#). Sign conventions for different installation locations shall comply with the sign conventions shown in [Figures D.1](#) to [D.16](#).

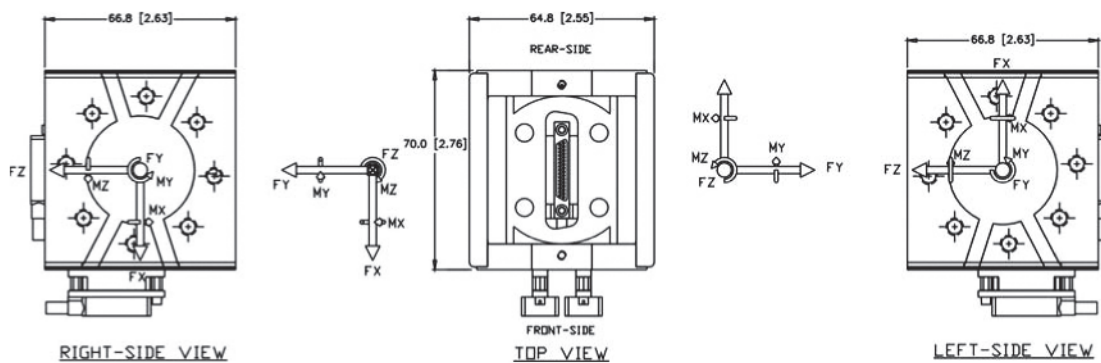


NOTE See [Figure D.2](#) for detailed sign conventions for the upper neck and [Figure D.3](#) for detailed sign conventions for the lower neck.

**Figure A.1 — Universal neck load cell**

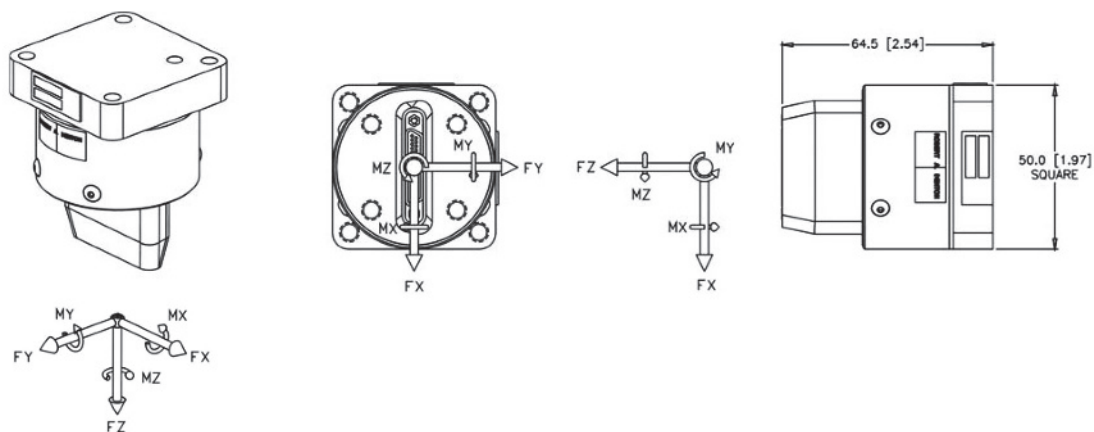


**Figure A.2 — Sacro-iliac load cell**



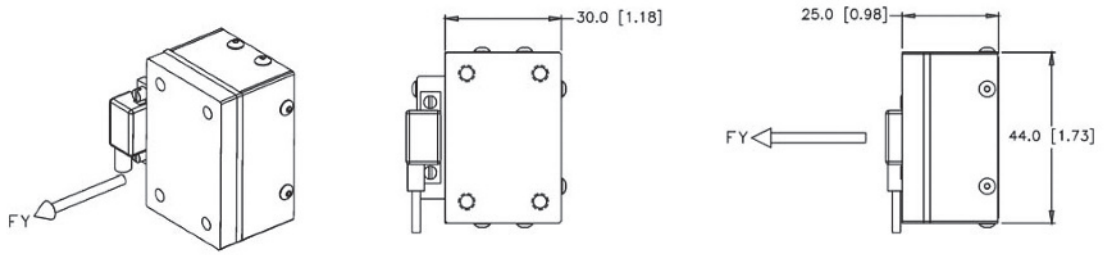
NOTE See [Figure D.11](#) for detailed sign conventions.

**Figure A.3 — Sacro-iliac load cell, right side, top, and left side views**



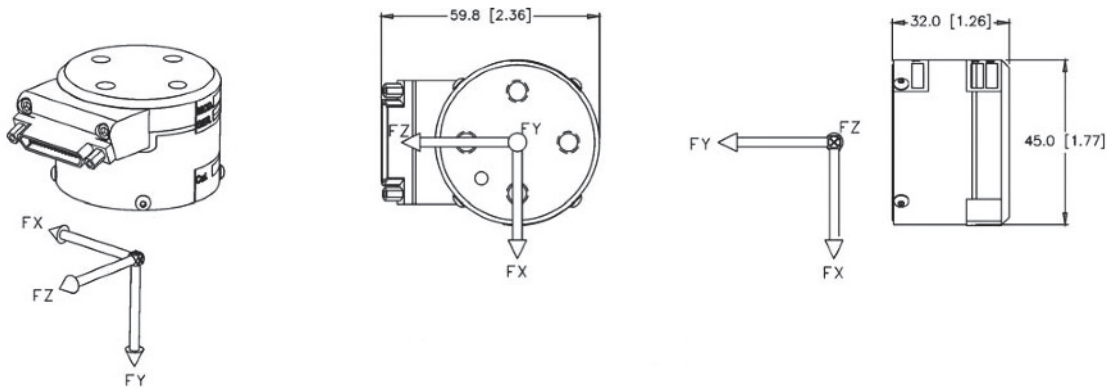
NOTE See [Figure D.10](#) for detailed sign conventions.

**Figure A.4 — Lumbar load cell**



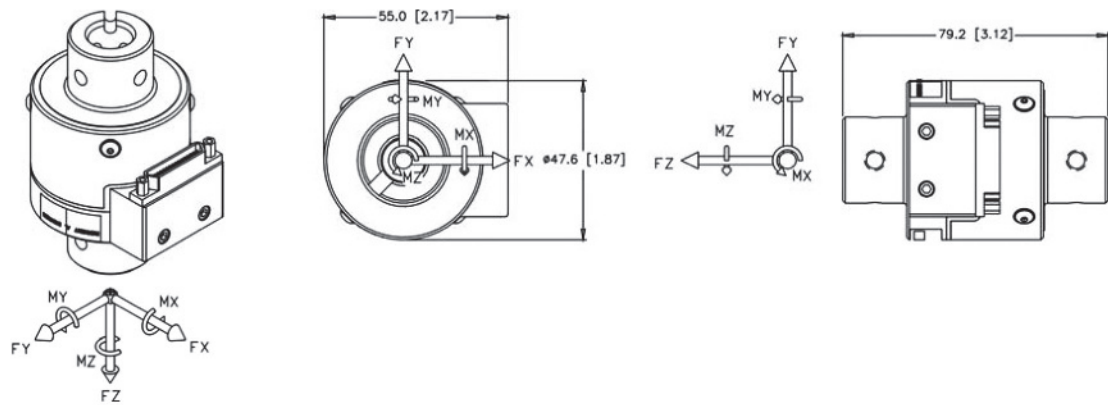
NOTE See [Figure D.12](#) for detailed sign conventions.

**Figure A.5 — Pubic symphysis load cell**



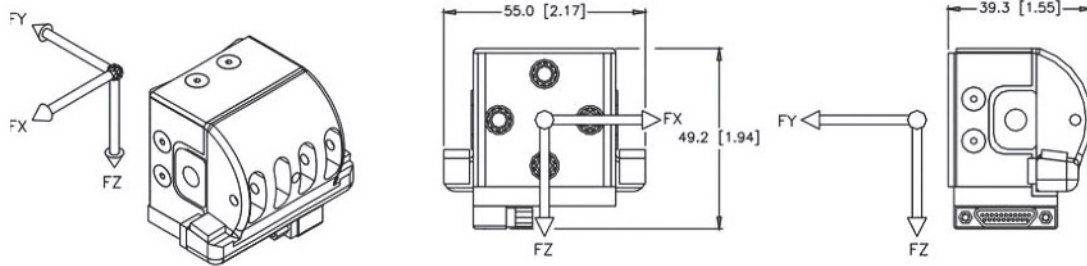
NOTE See [Figure D.13](#) for detailed sign conventions.

**Figure A.6 — Femoral neck load cell**



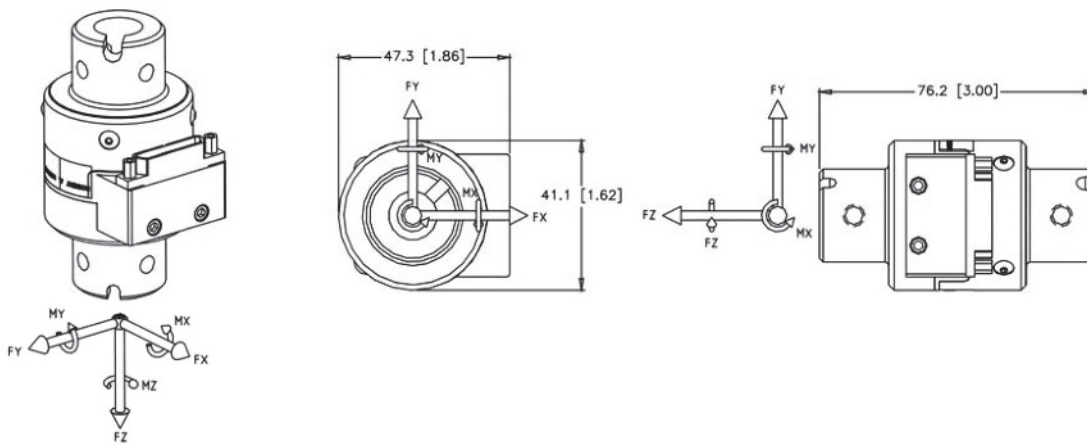
NOTE See [Figures D.14](#) and [D.16](#) for detailed sign conventions.

**Figure A.7 — Universal leg load cell**



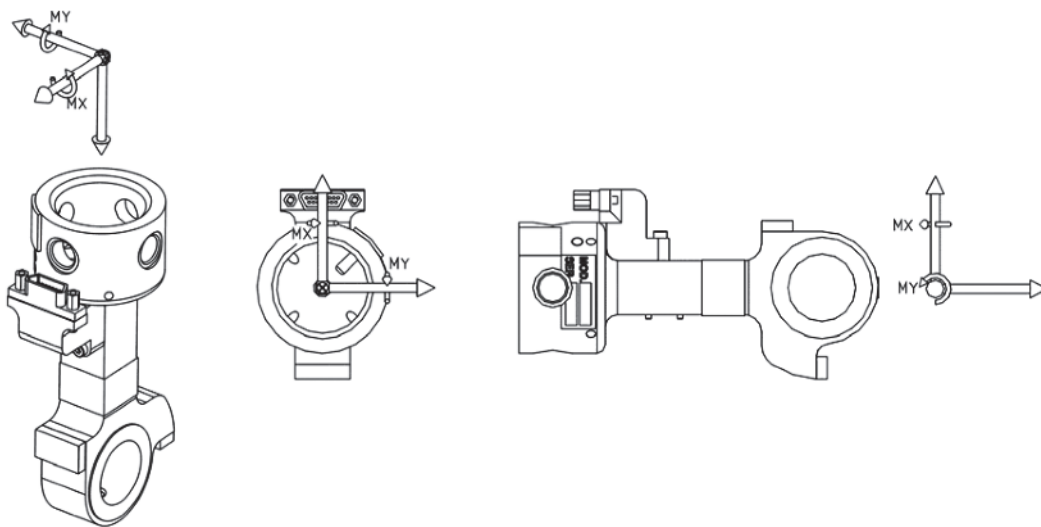
NOTE See [Figure D.6](#) for detailed sign conventions.

**Figure A.8 — Shoulder load cell**



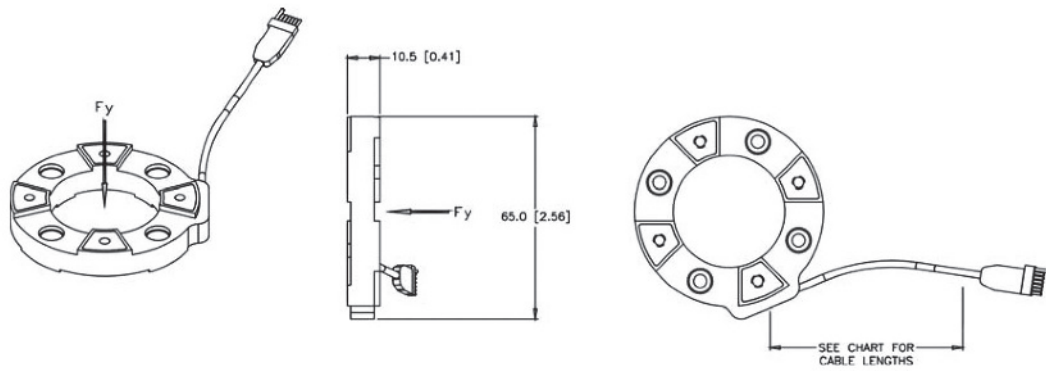
NOTE See [Figure D.8](#) for detailed sign conventions.

**Figure A.9 — Universal arm load cell**



NOTE See [Figure D.8](#) for detailed sign conventions.

**Figure A.10 — Elbow load cell**



NOTE See [Figure D.15](#) for detailed sign conventions.

**Figure A.11 — Knee contact load cell**

## Annex B (informative)

### Conventions for exemplar permissible load cells and angular displacement sensors

#### B.1 Overview

Development of the load cells for the WorldSID was sub-contracted to Robert A. Denton, Inc. (currently Humanetics). Designs of the load cells were primarily driven by the number and type of channels, capacity for each of the channels (including overload capacity), and the body part design, into which they were incorporated. The load cells and angular displacement sensors available for the WorldSID are shown in [Figure B.1](#).

The design intent was to minimize the number of types of loads cells in the WorldSID. The load cells in the spinal column, the upper and lower neck load cells, are identical and are identified as the universal neck load cell. The lumbar spine load cell was originally designed to be interchangeable with the universal neck load cell, but design constraints within the pelvis made this impossible in the final design. The load cells in the legs, the femur, and the upper and lower tibia are identical. The leg load cells are identified as the universal leg load cell. The arm load cells, upper and lower arm, are interchangeable. The remaining load cells of the WorldSID are unique in design.

Each load cell has self-identification internal to the load cell for increased efficiency and accuracy. The sensor ID component stores and reports the load cell's serial number and calibration data so that the calibration information for each device can be accessed by standard testing software.

#### B.2 Repeatability and reproducibility

Load cell repeatability and reproducibility can be assessed by load cell calibration. Repeatability and reproducibility are typically 1 % of full scale or less.

#### B.3 Durability

The load cells have unlimited durability for tests that do not exceed the full-scale ranges of the devices. Suggested cable routing procedures to protect cables and connectors are given in Annex G of ISO 15830-4. Cable or connector replacement may be required if these are damaged during use.

#### B.4 Sensitivity

All the load cells for WorldSID are strain gage-based devices with outputs of approximately 1 mV/V to 3 mV/V before amplification. These output levels are in the same range as other load cells currently used in the Hybrid III and other ATDs. The load cells have a temperature sensitivity of no greater than 0,06 % of reading per degree Celsius over a range of 16°C to 26°C.

#### B.5 Handling

All components are joined with metric fasteners and allow the use of standard hand tools. Assembly and disassembly instructions are described in ISO 15830-4. The load cells have a rigid cover or are encapsulated in a rugged plastic material and are internally sealed from moisture.

# Robert A. Denton WorldSID Instrumentation

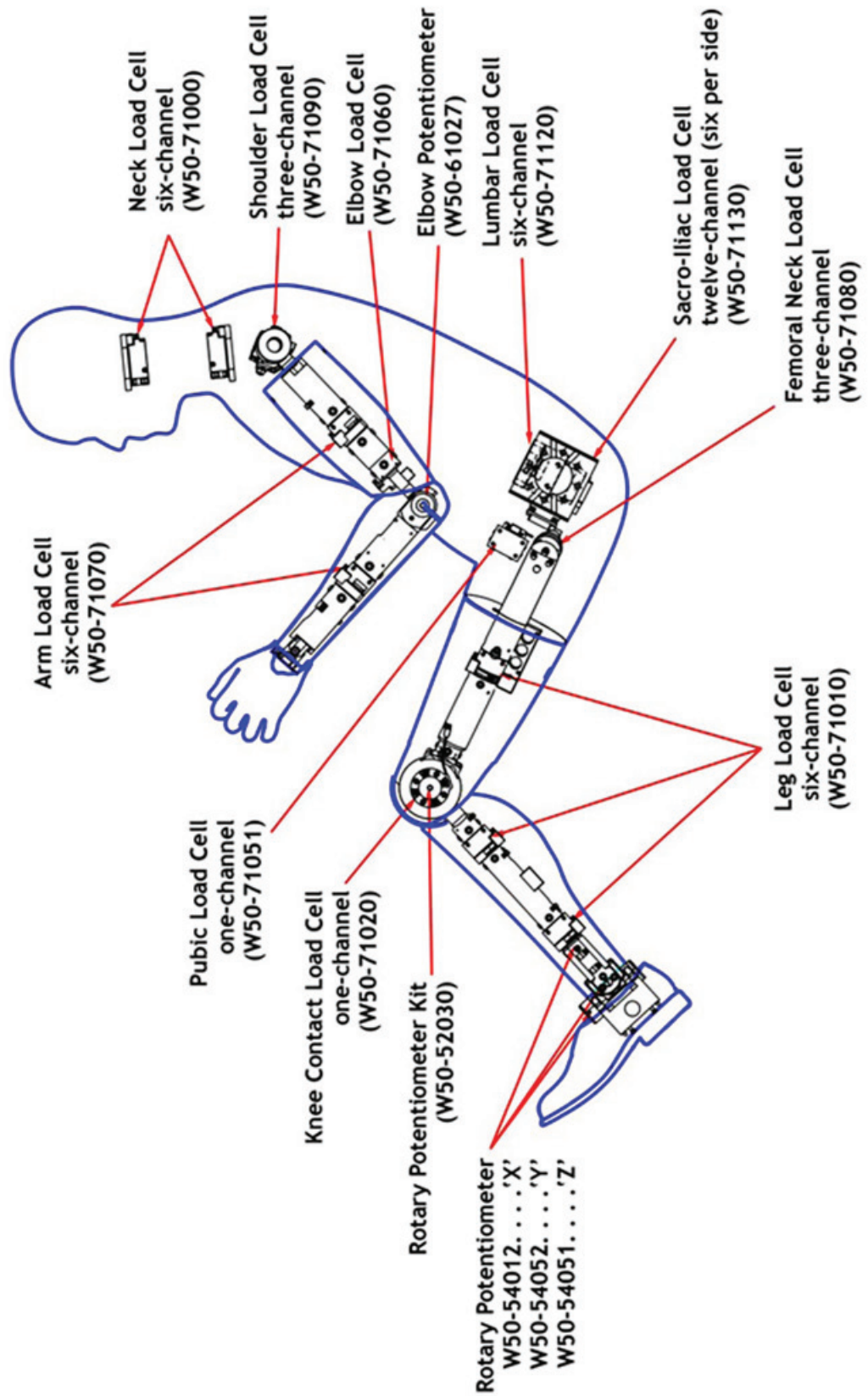


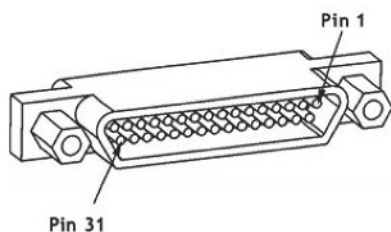
Figure B.1 — Humanetics (formerly Robert A. Denton) WorldSID instrumentation

## B.6 Calibration

All load cells are provided with a full-scale calibration data. Data are provided for nonlinearity, hysteresis, cross talk, and full-scale output. Re-calibration of each device should be performed every year or whenever the load cell is loaded over full capacity. The load cells are removed from the WorldSID for calibration. Each load cell has a unique calibration fixture to mount the load cell in the correct orientation for calibration.

## B.7 Load cell connector pin codes

Humanetics (formerly Denton) load cell connector pin usage is shown in [Figures B.2](#) to [B.8](#).



CHANNEL	PIN	COLOR	FUNCTION
FX	1	BROWN	+EXCITATION
FX	17	RED	+SIGNAL
FX	2	ORANGE	-EXCITATION
FX	18	YELLOW	-SIGNAL
FX	3	TAN	CHANNEL IDENTIFICATION
FY	19	RED/STRIPE	+EXCITATION
FY	4	BLACK	+SIGNAL
FY	20	WHITE	-EXCITATION
FY	5	BLACK/STRIPE	-SIGNAL
FY	21	PINK	CHANNEL IDENTIFICATION
FZ	6	GREEN	+EXCITATION
FZ	22	BLUE	+SIGNAL
FZ	7	VIOLET	-EXCITATION
FZ	23	GREY	-SIGNAL
FZ	8	CLEAR	CHANNEL IDENTIFICATION
SHIELD	24	SHIELD	GROUND
MX	9	BROWN	+EXCITATION
MX	25	RED	+SIGNAL
MX	10	ORANGE	-EXCITATION
MX	26	YELLOW	-SIGNAL
MX	11	TAN	CHANNEL IDENTIFICATION
MY	27	RED/STRIPE	+EXCITATION
MY	12	BLACK	+SIGNAL
MY	28	WHITE	-EXCITATION
MY	13	BLACK/STRIPE	-SIGNAL
MY	29	PINK	CHANNEL IDENTIFICATION
MZ	14	GREEN	+EXCITATION
MZ	30	BLUE	+SIGNAL
MZ	15	VIOLET	-EXCITATION
MZ	31	GREY	-SIGNAL
MZ	16	CLEAR	CHANNEL IDENTIFICATION

Figure B.2 — Connector wiring, 31-pin, 6 channels



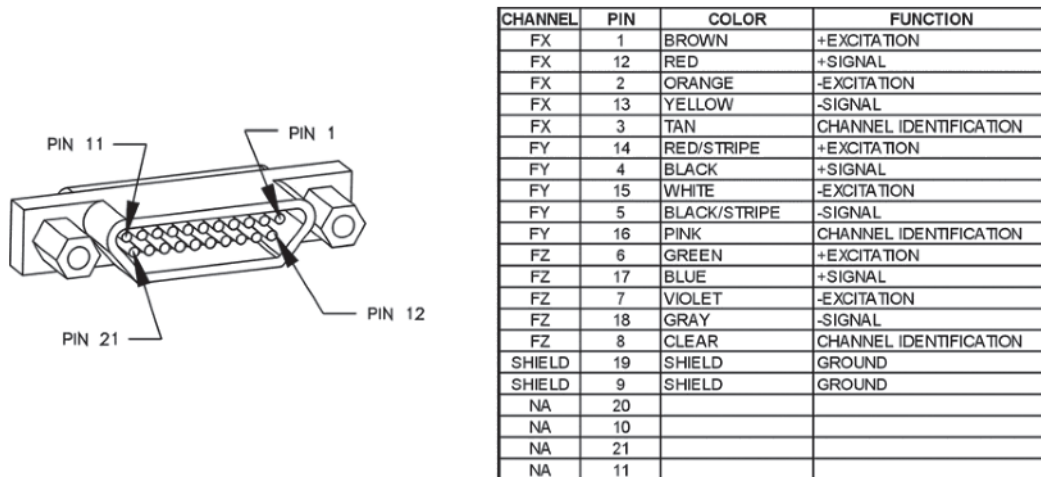


Figure B.3 — Connector wiring, 21-pin, 3 channels (shoulder)

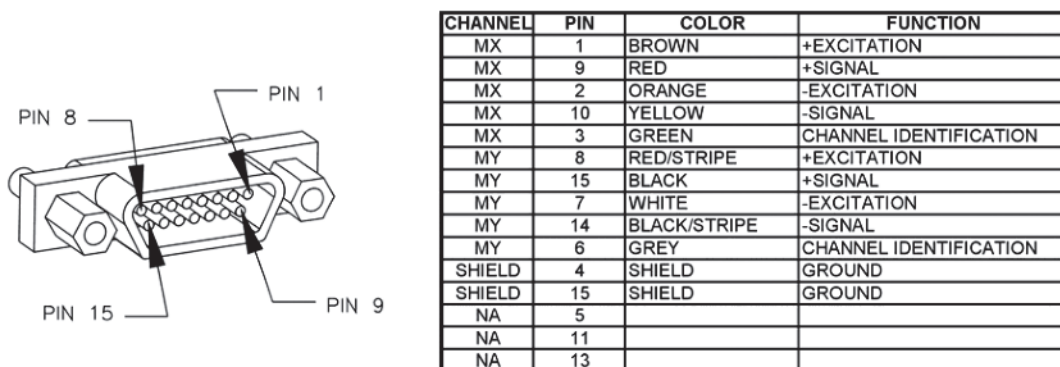


Figure B.4 — Connector wiring, 15-pin, 2 channels (elbow load cell)

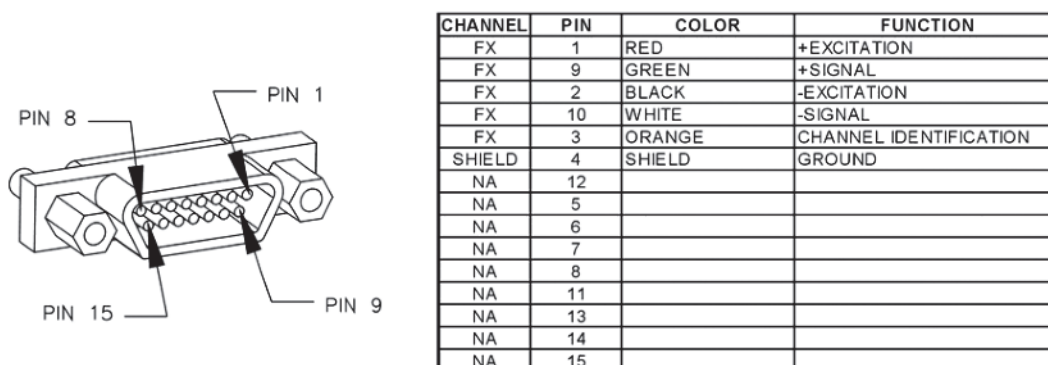


Figure B.5 — Connector wiring, 15-pin, 1 channel (side exit, pubic)

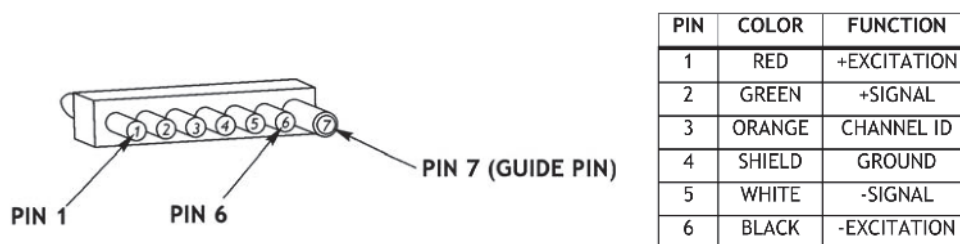


Figure B.6 — 1-channel connector to G5 DAS (configuration shown was only used in some WorldSID assemblies)

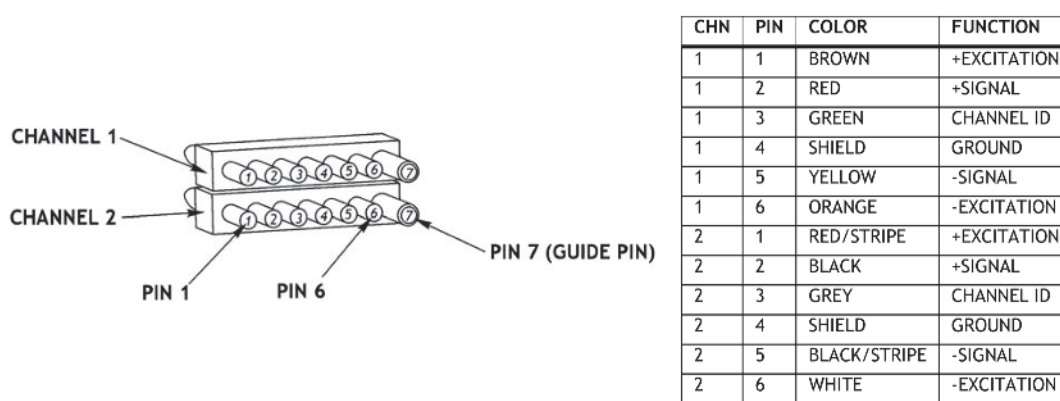


Figure B.7 — 2-channel connector to G5 DAS (configuration shown was only used in some WorldSID assemblies)

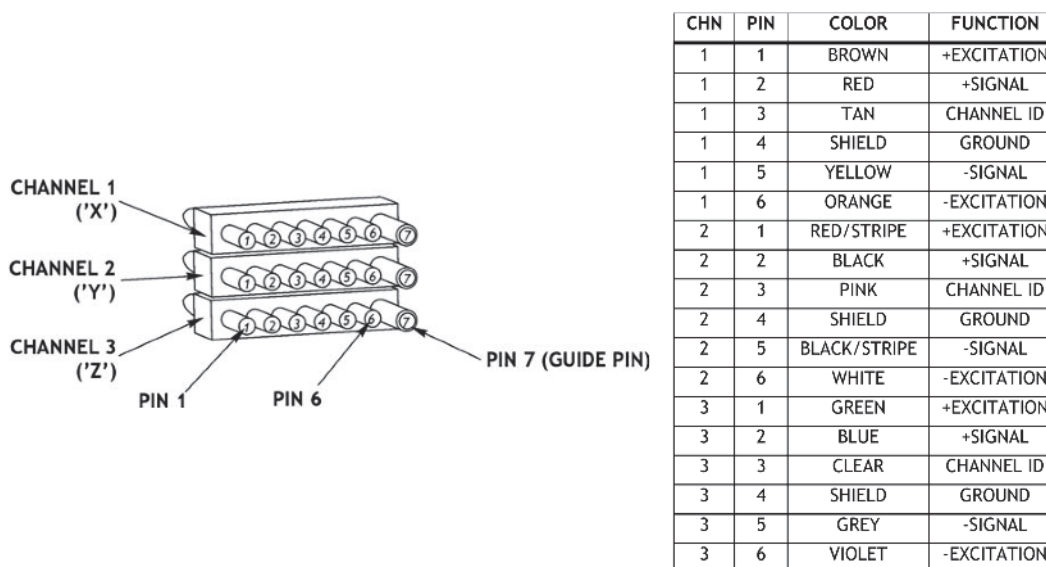


Figure B.8 — 3-channel connector to G5 DAS (configuration shown was only used in some WorldSID assemblies)

## **B.8 Universal neck load cell (W50-71000)**

The two universal neck load cells are used to measure three force and three moment channels near the occipital condyle and T1 (first thoracic vertebra or the base of the neck). In the upper neck position (occipital condyle), the load cell attaches to the base of the skull instrumentation core and the flexible neck element. In the lower neck position (T1), the load cell attaches to the flexible neck element and the lower neck bracket.

## **B.9 Sacro-iliac load cell (W50-71130)**

The sacro-iliac load cell consists of two 6-channel load cells (left and right) manufactured as a one-piece unit. The sacro-iliac (SI) load cell forms the structure within the WorldSID pelvis that joins the left and right iliac wings to each other as well as the lumbar spine. The location of the load cell is similar to the human sacrum. The iliac wings are bolted to the sides of the load cell. The structure of the load cell has a rear-mounting surface that has provisions to mount the pelvis accelerometers and tilt sensors. The lumbar spine load cell mounts internally to the SI load cell. The lower surface of the lumbar load cell is bolted to the SI load cell.

This load cell measures the complex interaction of forces within the sacrum. An impact to the left side of the pelvis will transfer forces and moments through the pelvis bone into both the pubic area and the sacrum. At the sacrum, the forces and moments may transfer into the right side of the pelvis bone and the lumbar spine. This load cell along with the lumbar spine load cell will provide data to understand this interaction.

## **B.10 Lumbar load cell (W50-71120)**

The lumbar load cell is used to measure three force and three moment channels in the lumbar spine at the point of attachment to the pelvis. The lumbar load cell is installed into the sacro-iliac load cell. The connector exits at the base of the sacro-iliac. The data recorded from this device provides information about the forces and moments that occur at the lumbar region of the spinal column.

## **B.11 Pubic symphysis load cell (W50-71051)**

The pubic symphysis load cell measures one force ( $F_y$ ) channel. The load cell forms the structure that joins the left and right halves of the pelvis bone at the pubic symphysis. By application of a load cell at the pubic symphysis, the data acquired may provide a better understanding of the complex interactions taking place in this area.

## **B.12 Femoral neck load cell (W50-71080)**

The initial femoral neck load cell measures three forces at the junction in the WorldSID between the greater trochanter and the femoral neck. The forces and moments measured are the total being transferred from either the leg or from impact to the trochanter into the acetabulum. The inner surface of the load cell attaches to the femoral shaft and head. The outer surface of the load cell is attached to the trochanter.

## **B.13 Universal leg load cell (W50-71010)**

The leg load cell is positioned in three locations in the complete leg assembly: the mid-femur position and the upper and lower tibia positions. The leg load cell is a six-channel design that measures three forces and three bending moments.

### **B.14 Shoulder load cell (W50-71090)**

The shoulder load cell measures three forces at the junction of the arm and shoulder. The inboard surface of the shoulder load cell is attached to the shoulder rib element. The outer surface of the load cell contains the pivot assembly for the *X* rotation of the arm as well as stops that limit the range of motion. This load cell measures the interaction forces between the arm and shoulder as well as direct impact forces to the shoulder.

### **B.15 Universal arm load cell (W50-71070)**

The arm load cell is used in two locations on each full arm assembly. The load cell is positioned in the middle of the upper arm bone and in the middle of the lower arm bone. The arm load cell measures three force and three moment channels.

### **B.16 Elbow load cell (W50-71060)**

The elbow load cell measures two bending moment channels in the upper arm assembly at a point just above the elbow pivot joint.

### **B.17 Knee contact load cell (W50-71020)**

The knee contact load cells are designed to measure direct impact to the knee from an external source as well as knee-to-knee contact forces. Two knee contact load cells are used on each WorldSID leg. The knee contact load cell measures one force channel.

## **Annex C** (informative)

### **Conventions for permissible accelerometers**

#### **C.1 Overview**

Development of the linear and rotational accelerometers for the WorldSID was sub-contracted to Endevco, Inc. Designs of the accelerometers were primarily driven by space constraints, mounting requirements, signal range, and frequency response. It should be noted that different connector configurations may be found in different WorldSID assemblies; thus, connectors shown are examples only.

#### **C.2 Linear accelerometer connector pin codes**

Linear accelerometer pin assignment is shown in [Figure C.1](#).

#### **C.3 Rotational accelerometer connector pin codes**

Rotational accelerometer pin assignment is shown in [Figure B.6](#).

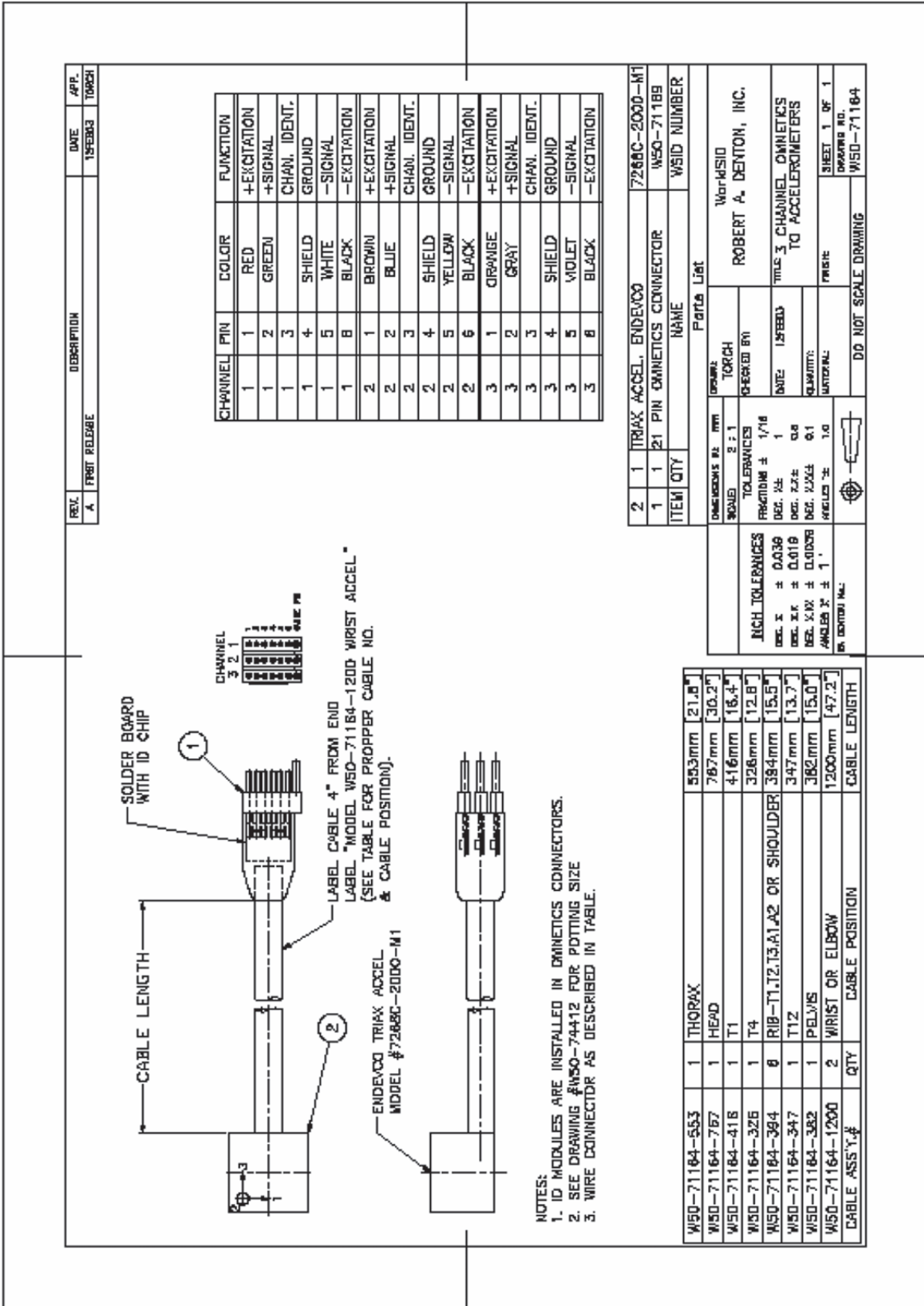


Figure C.1 — Linear accelerometer wiring

## **Annex D** (normative)

### **Information regarding sensor output polarities**

#### **D.1 Overview**

In order to minimize the number of specialized load cells and accelerometers required for the WorldSID, universal sensors which are capable of being mounted in different locations (e.g. the universal leg load cell is used in three different locations) were designed. As units are moved from one location to another, the resulting signal polarity may change.

Users of the WorldSID should familiarize themselves with the polarity of each unit in each mounting location and orientation.

#### **D.2 Sensor output polarity diagrams**

Diagrams detailing sensor output polarity are shown in [Figures D.1](#) to [D.16](#). These are based on SAE J211-1.





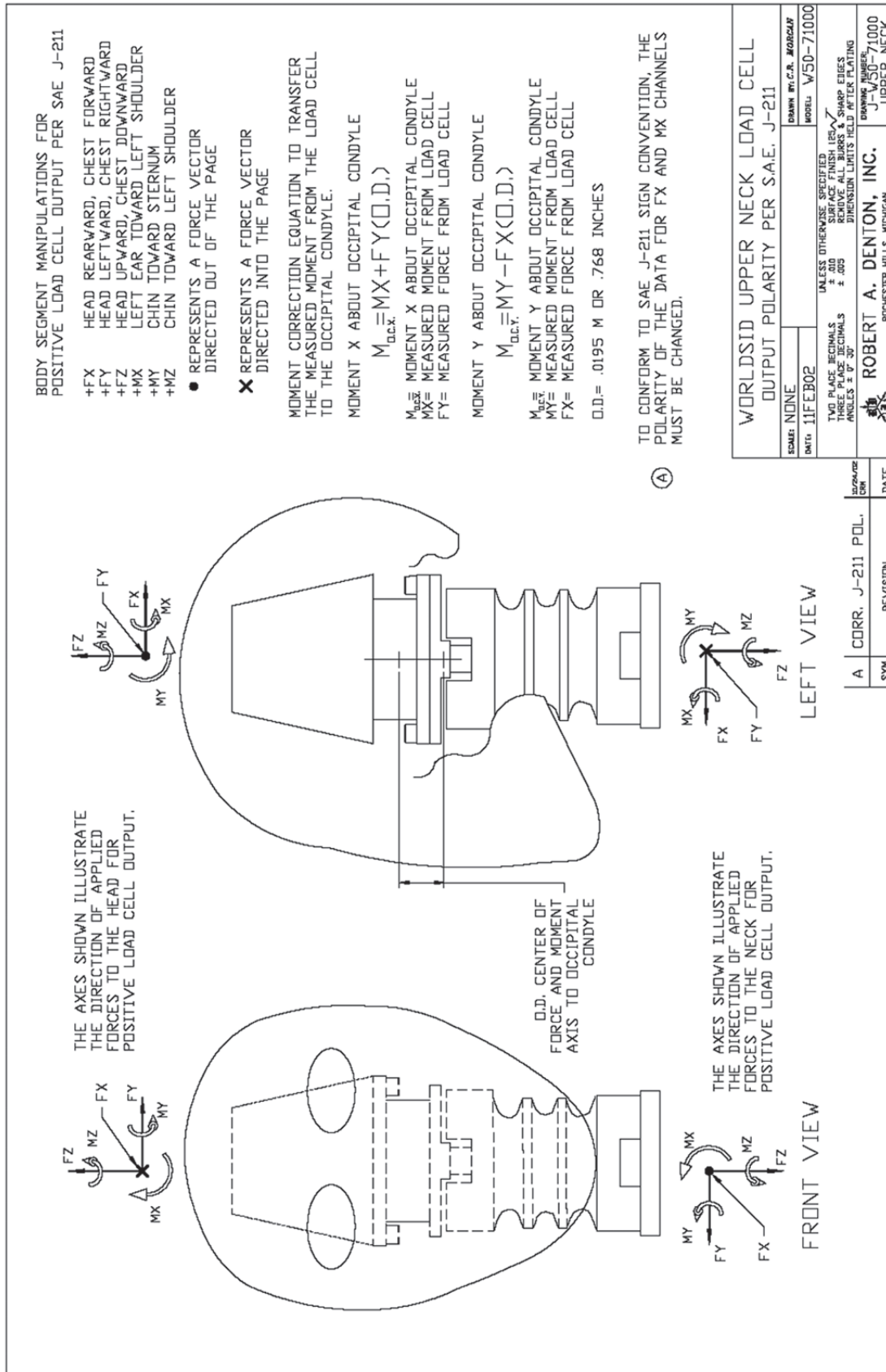


Figure D.2 — Upper neck load cell



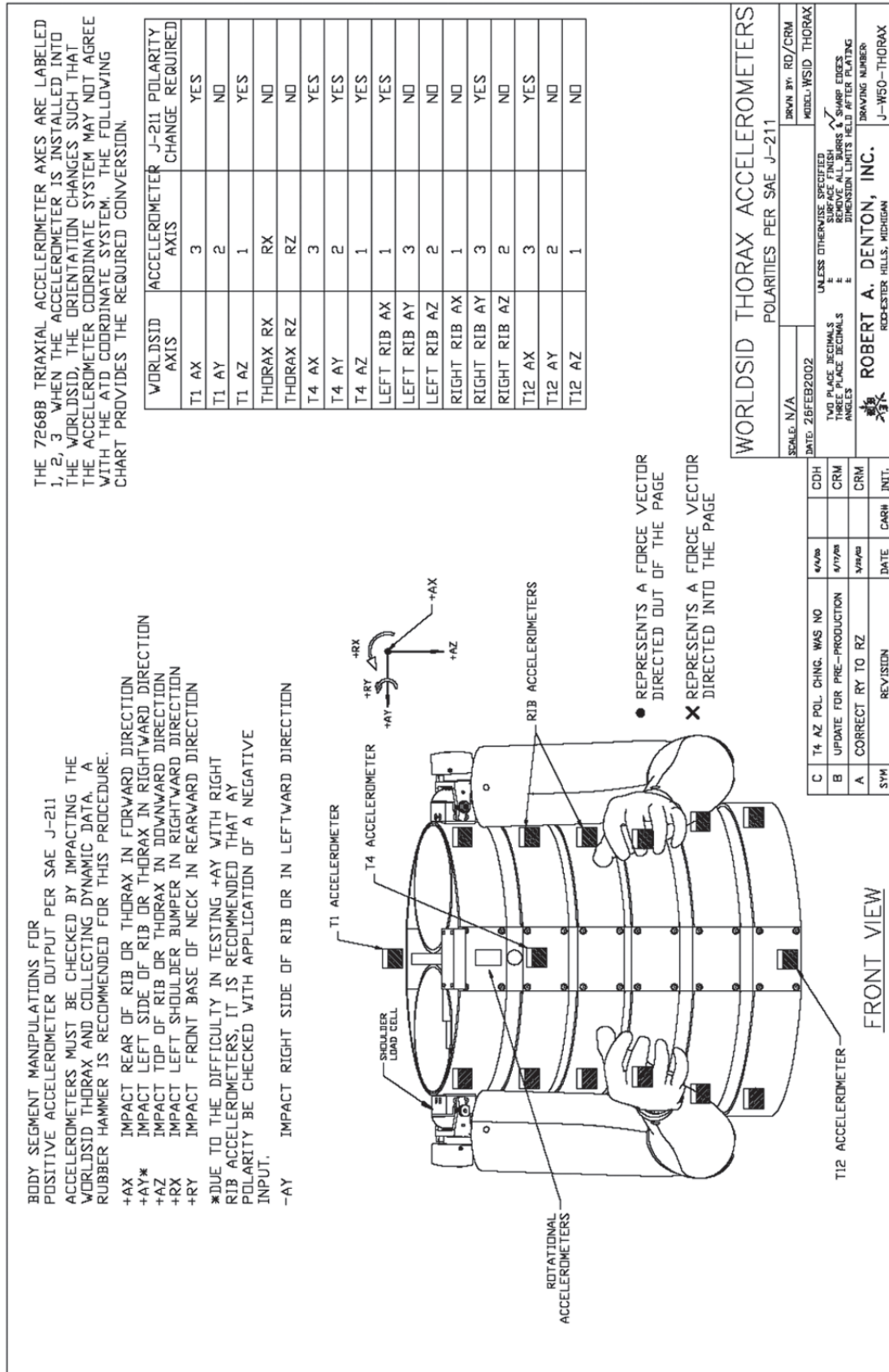


Figure D.4 — Thorax accelerometers

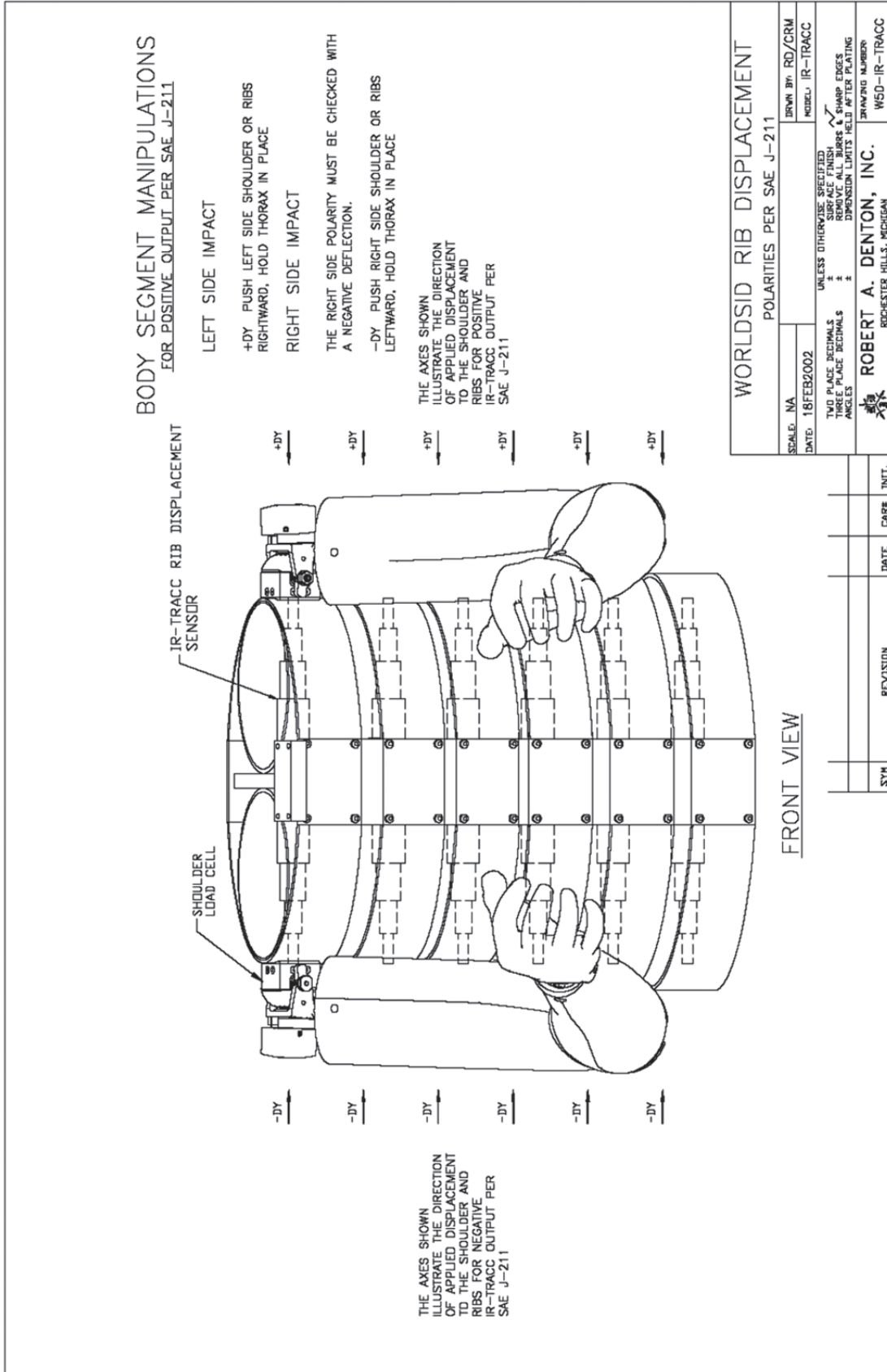


Figure D.5 — Rib displacement

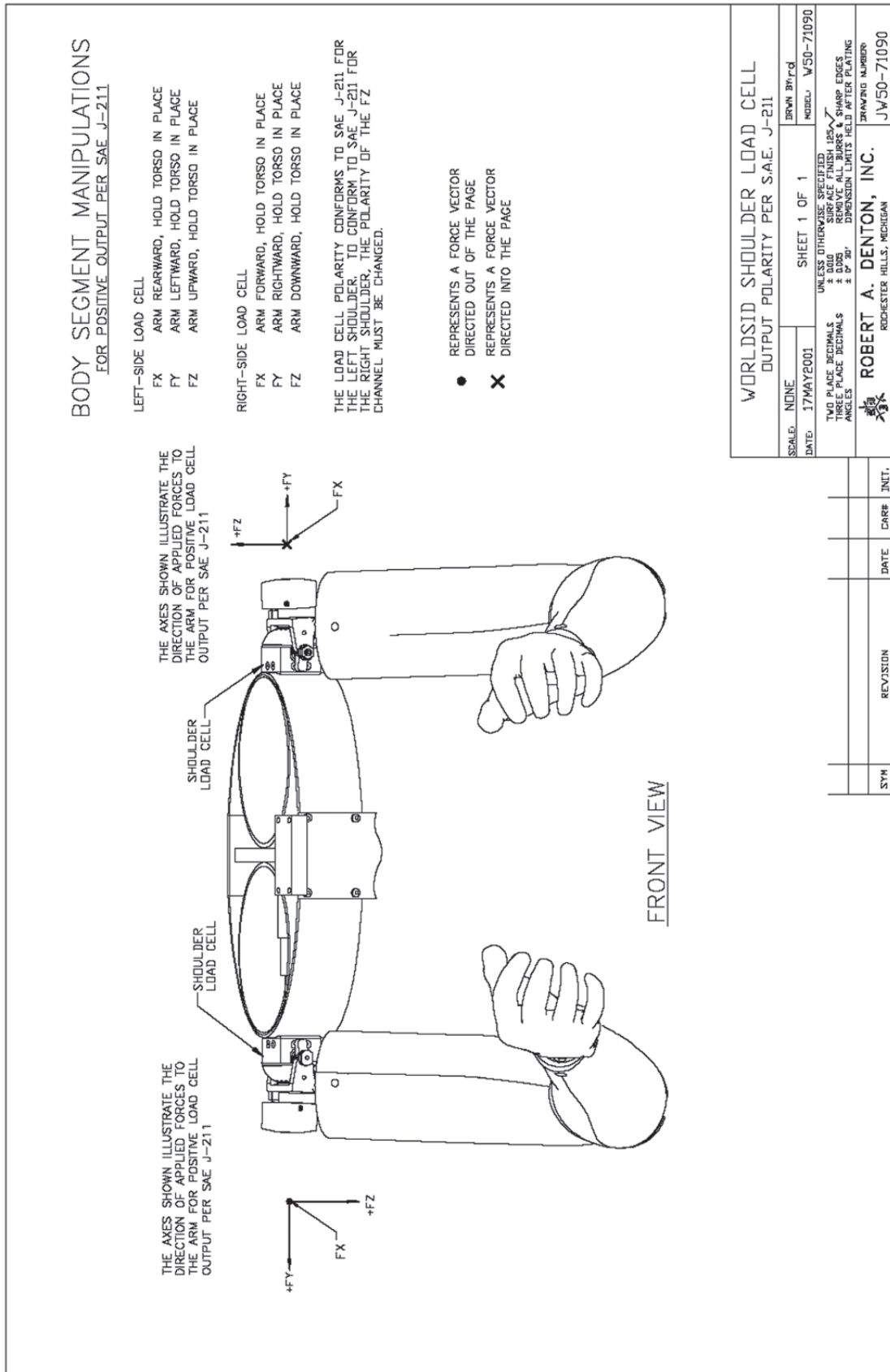


Figure D.6 — Shoulder load cell

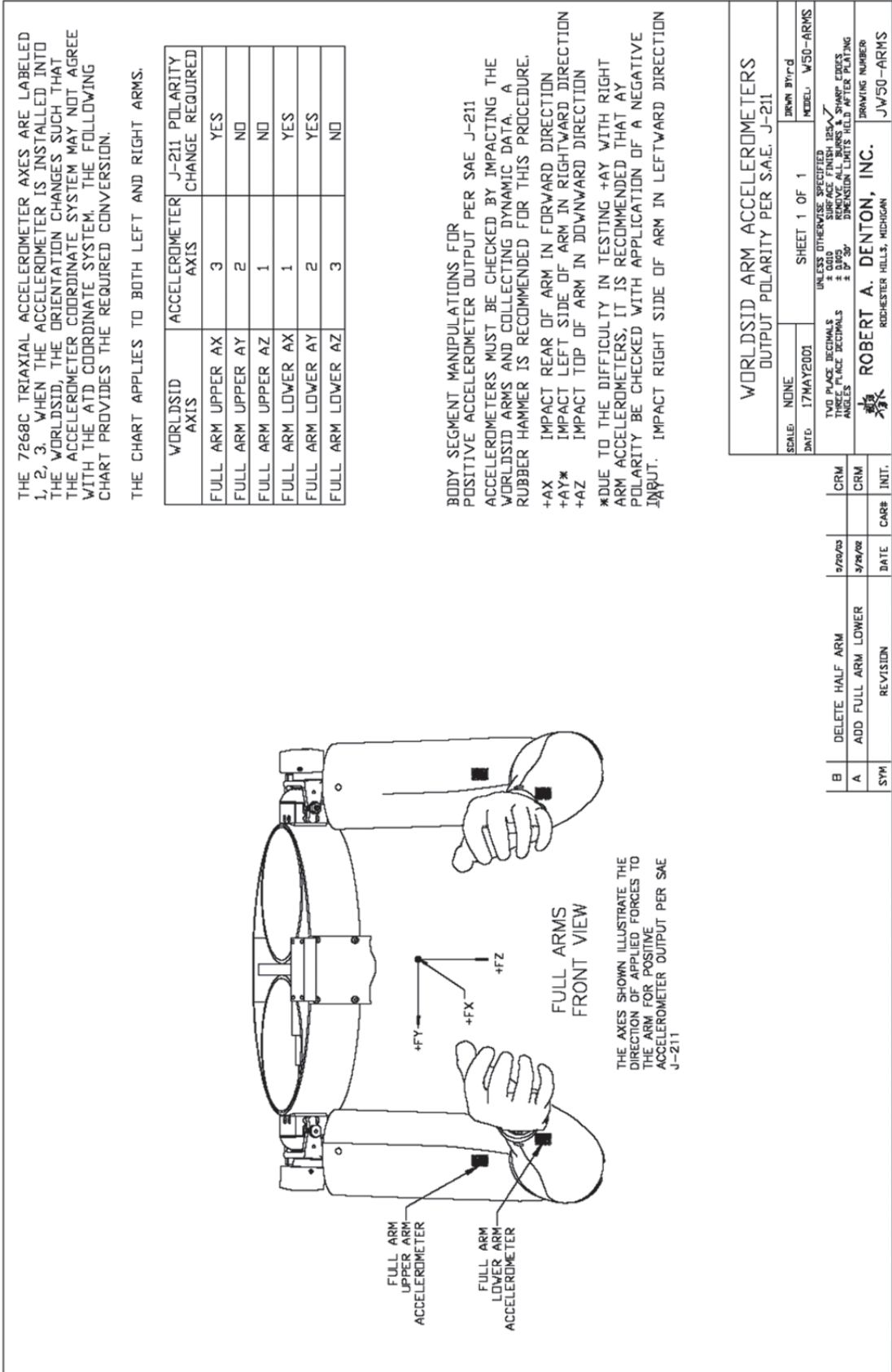


Figure D.7 — Arm accelerometers



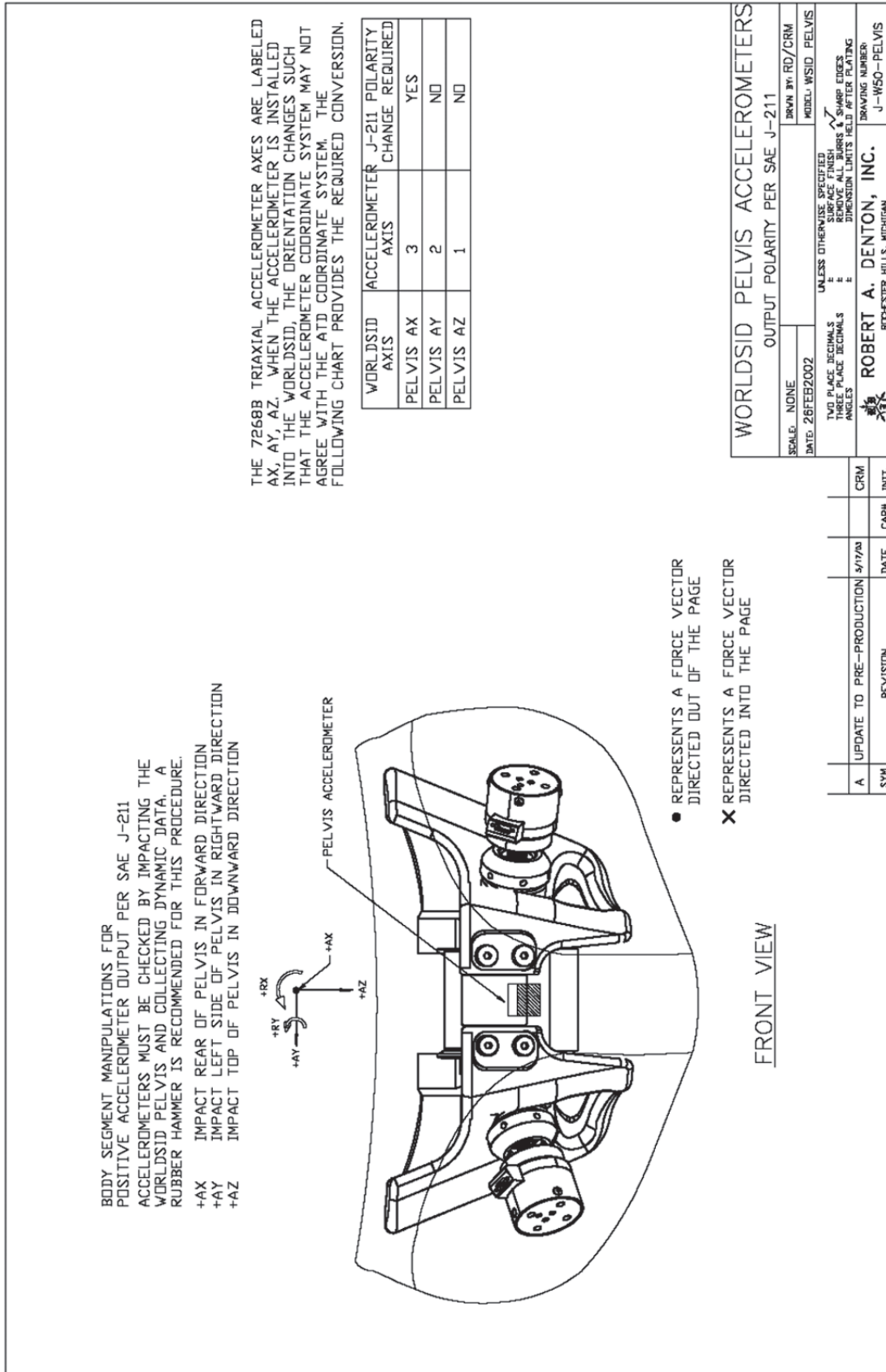


Figure D.9 — Pelvis accelerometers



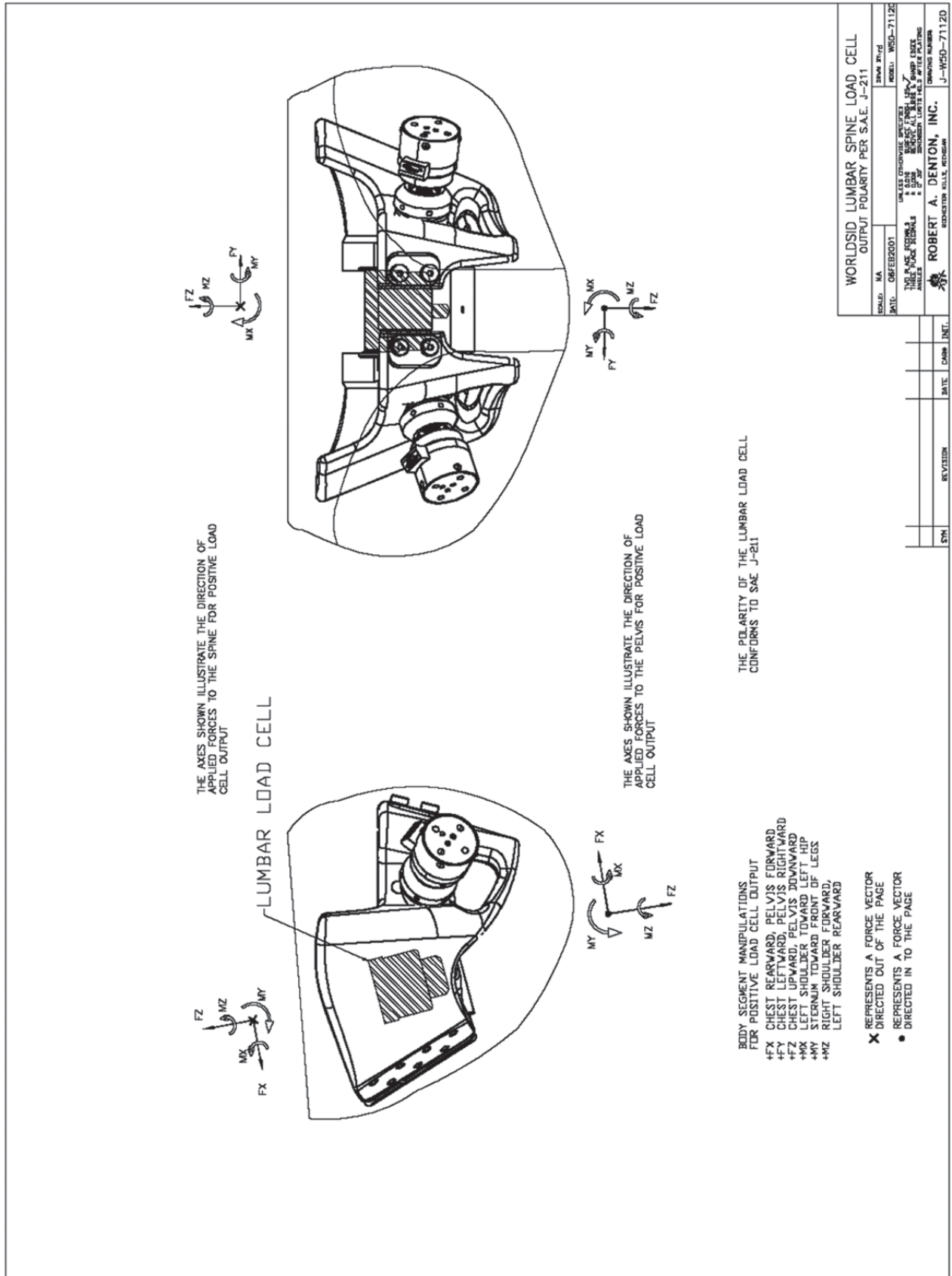


Figure D.10 — Lumbar spine load cell

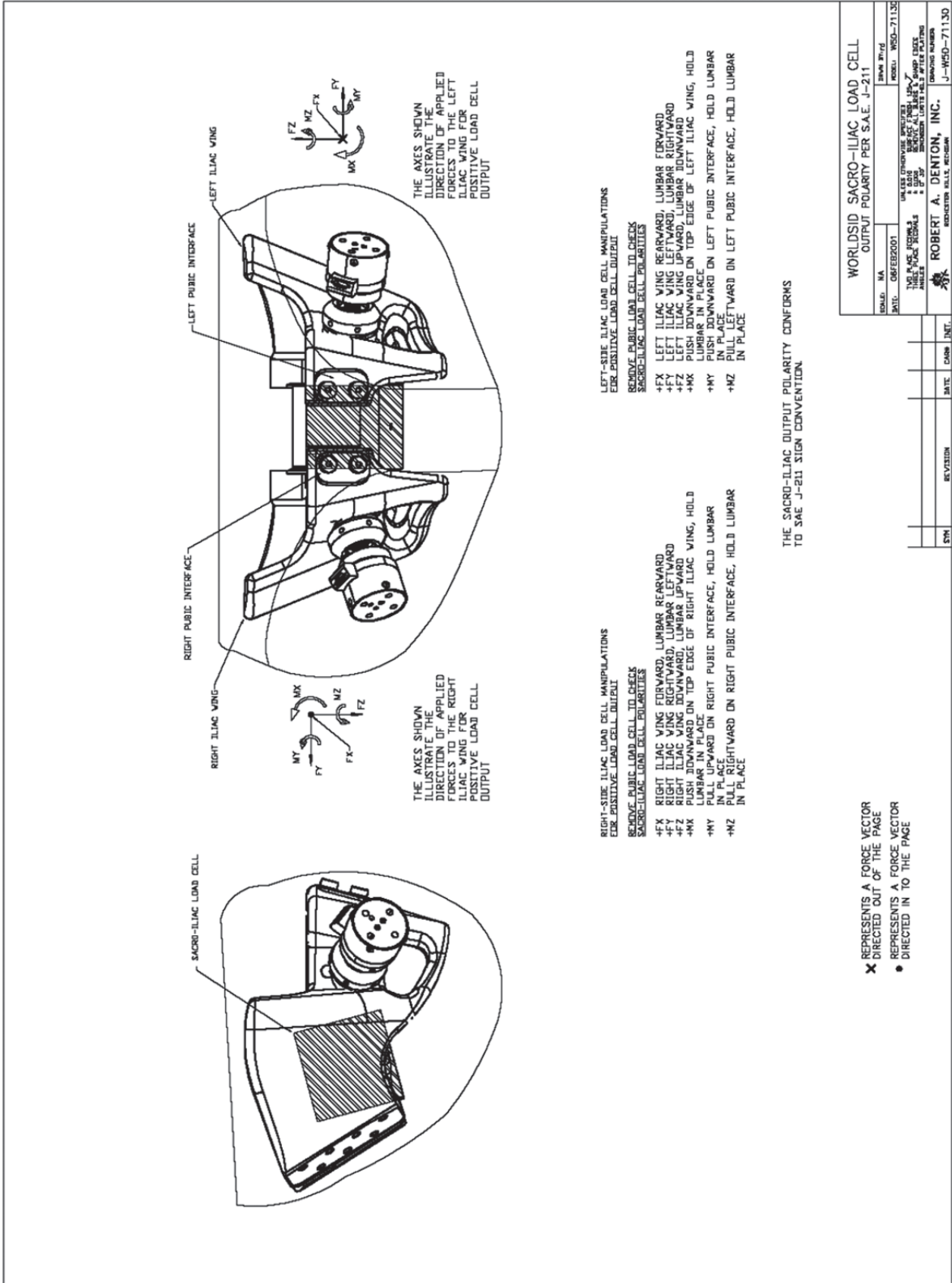


Figure D.11 — Sacro-iliac load cell

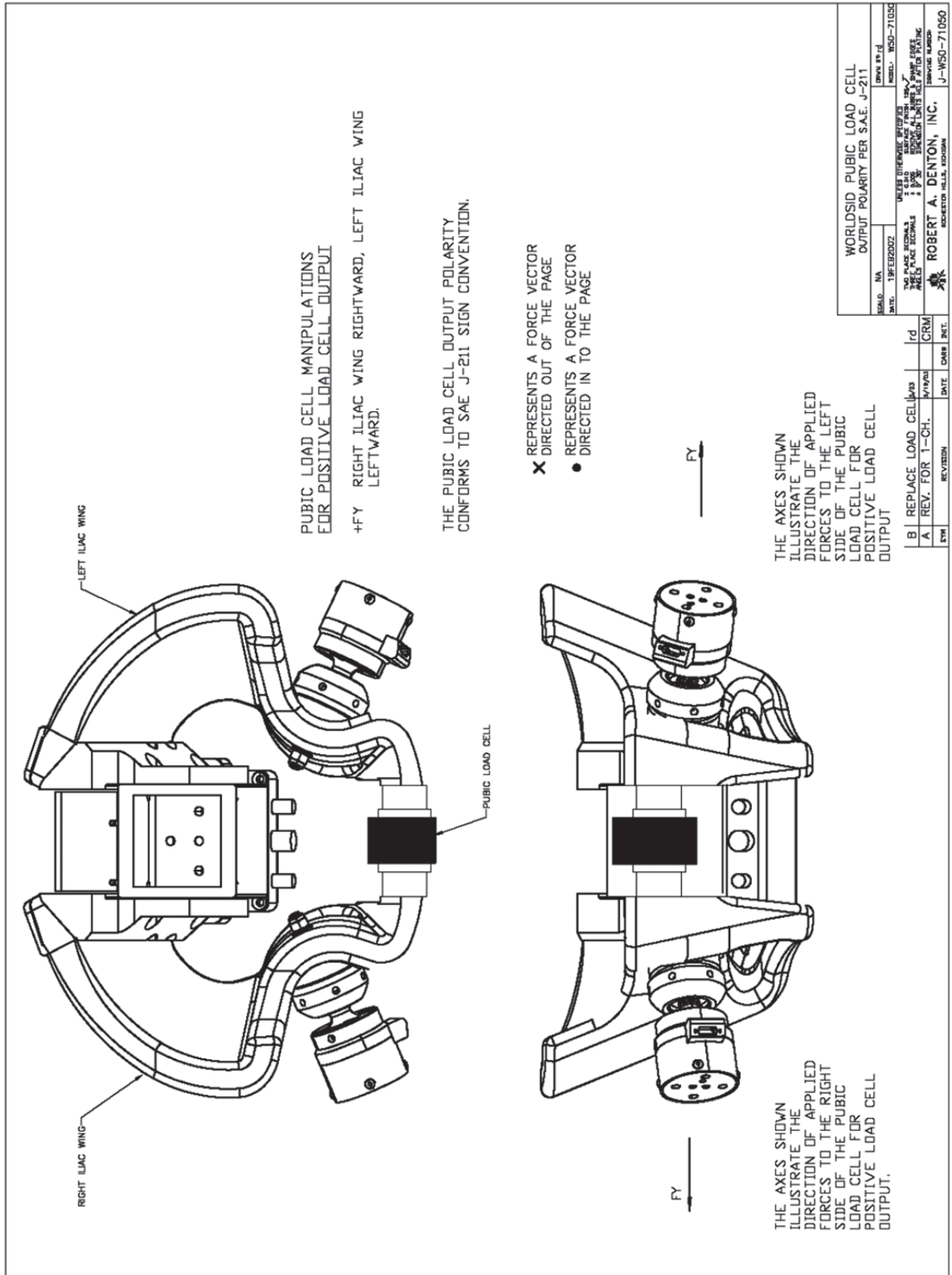


Figure D.12 — Pubic load cell

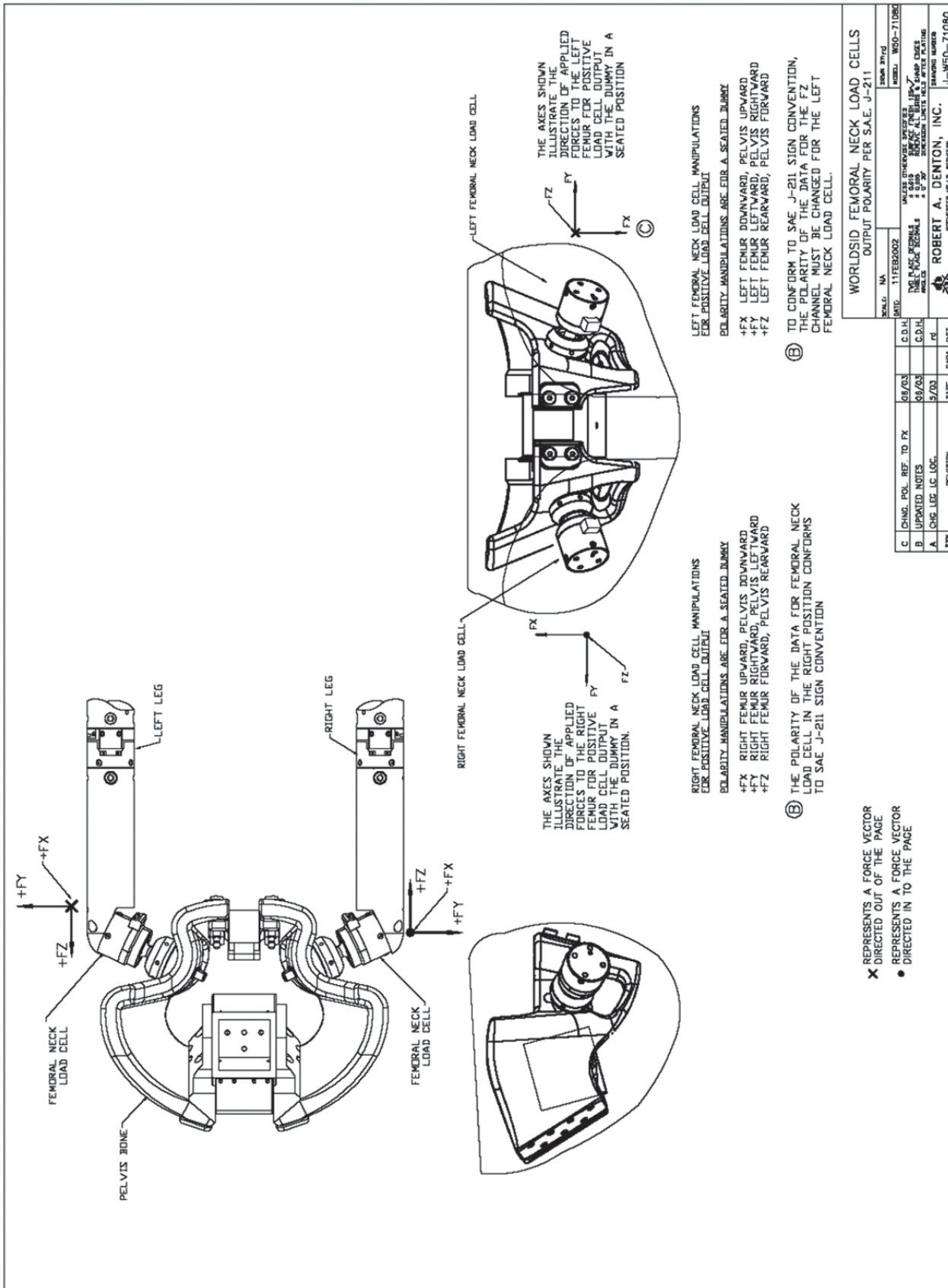


Figure D.13 — Femoral neck load cells



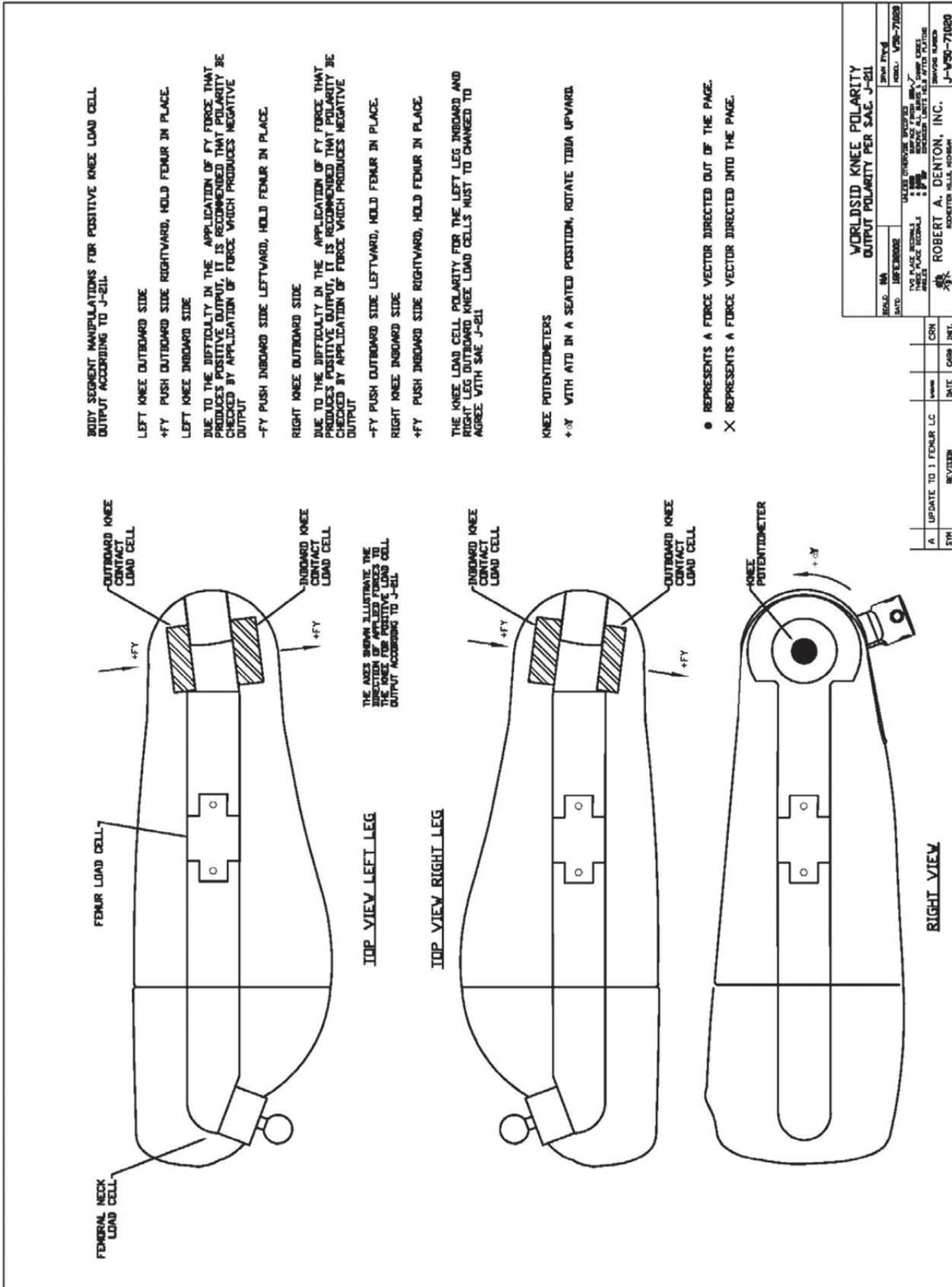


Figure D.15 — Knee load cells

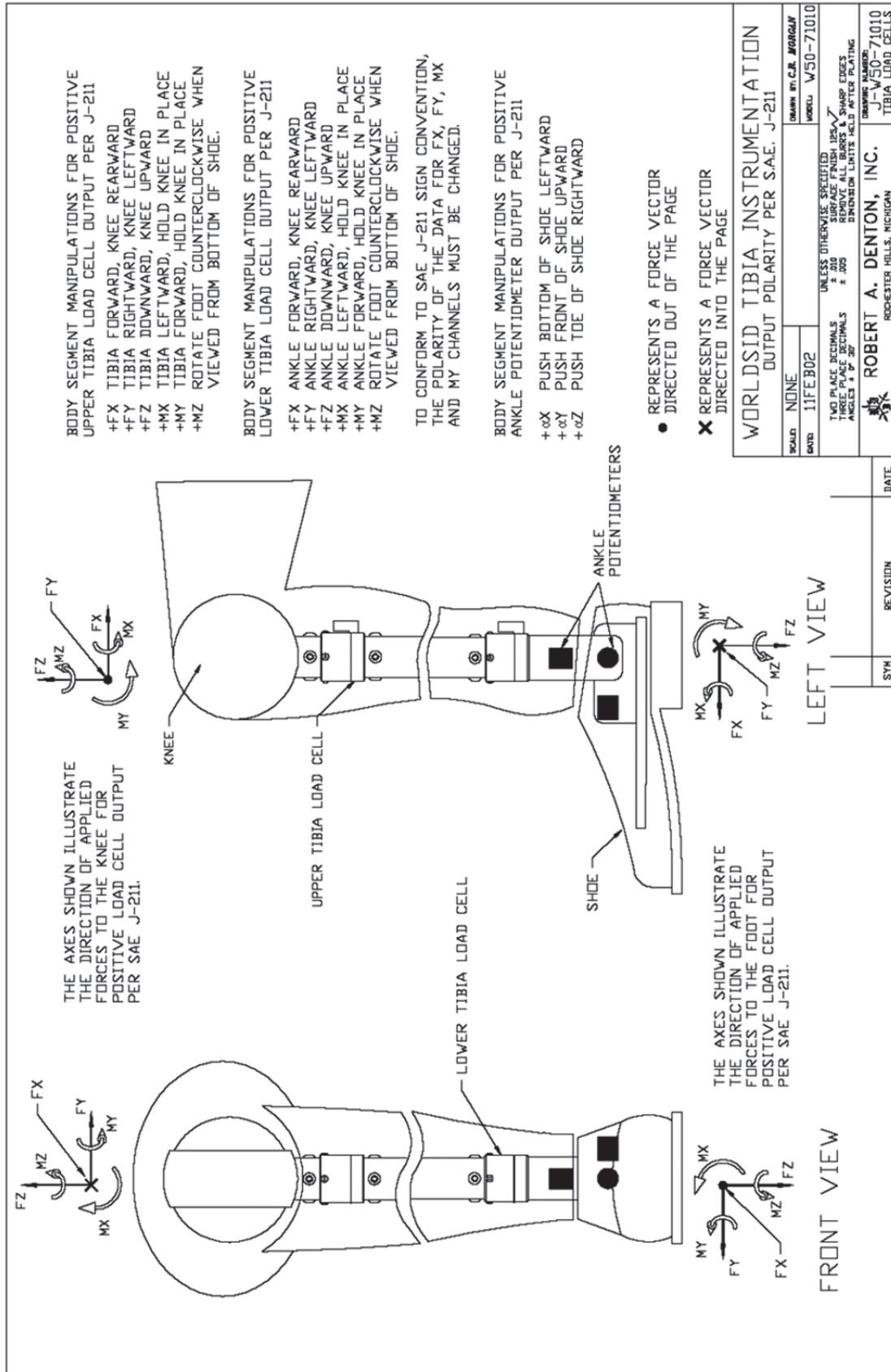


Figure D.16 — Tibia instrumentation

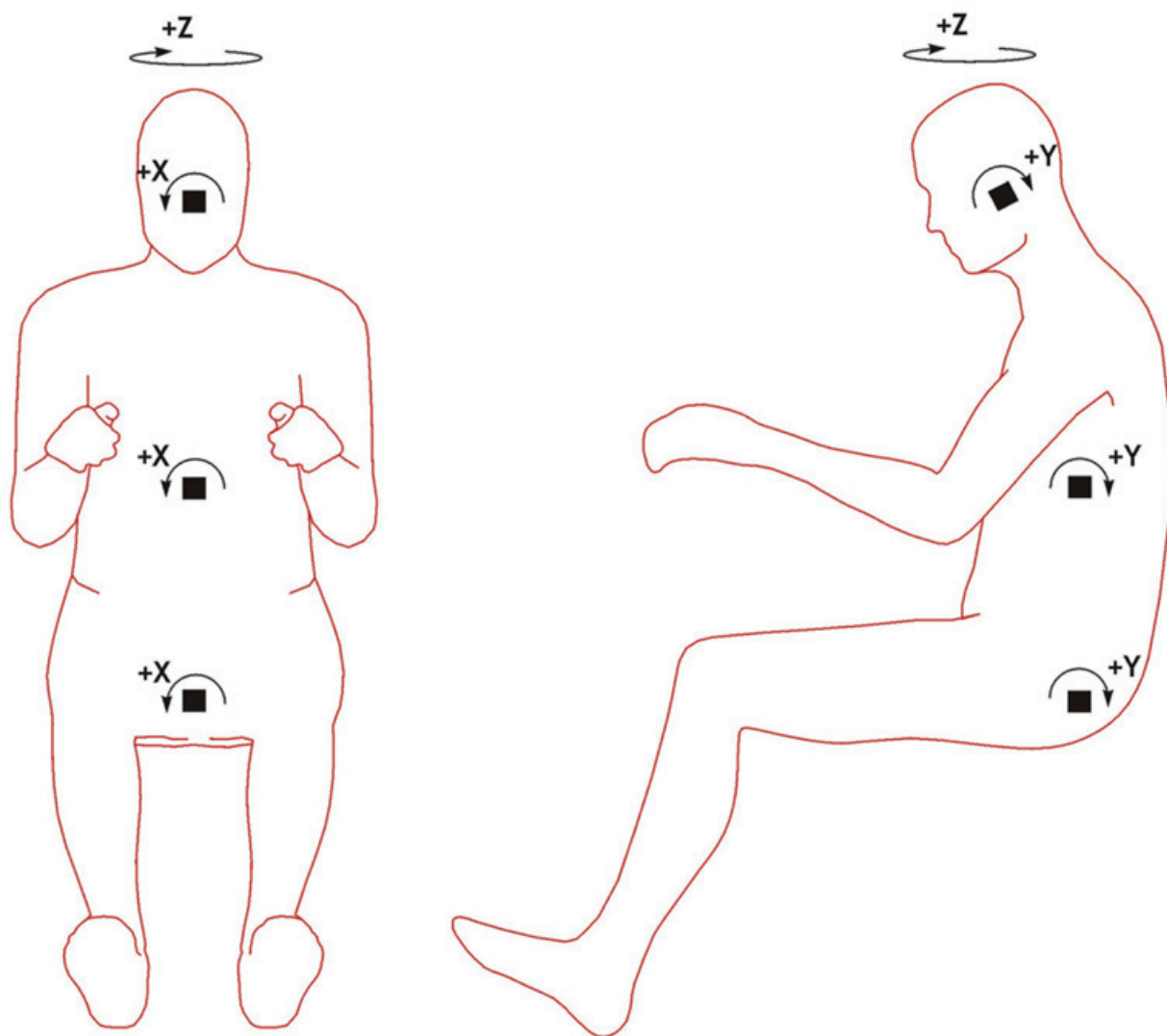


Figure D.17 — Tilt sensor channel orientations



## Bibliography

- [1] ISO 15830-4:2013, *Design and performance specifications for the WorldSID 50th percentile adult male side impact dummy — Part 4: User's manual*
- [2] SAE J211-1:2007, *Instrumentation for impact test – Part 1: Electronic instrumentation*





# British Standards Institution (BSI)

BSI is the national body responsible for preparing British Standards and other standards-related publications, information and services.

BSI is incorporated by Royal Charter. British Standards and other standardization products are published by BSI Standards Limited.

## About us

We bring together business, industry, government, consumers, innovators and others to shape their combined experience and expertise into standards-based solutions.

The knowledge embodied in our standards has been carefully assembled in a dependable format and refined through our open consultation process. Organizations of all sizes and across all sectors choose standards to help them achieve their goals.

## Information on standards

We can provide you with the knowledge that your organization needs to succeed. Find out more about British Standards by visiting our website at [bsigroup.com/standards](http://bsigroup.com/standards) or contacting our Customer Services team or Knowledge Centre.

## Buying standards

You can buy and download PDF versions of BSI publications, including British and adopted European and international standards, through our website at [bsigroup.com/shop](http://bsigroup.com/shop), where hard copies can also be purchased.

If you need international and foreign standards from other Standards Development Organizations, hard copies can be ordered from our Customer Services team.

## Subscriptions

Our range of subscription services are designed to make using standards easier for you. For further information on our subscription products go to [bsigroup.com/subscriptions](http://bsigroup.com/subscriptions).

With **British Standards Online (BSOL)** you'll have instant access to over 55,000 British and adopted European and international standards from your desktop. It's available 24/7 and is refreshed daily so you'll always be up to date.

You can keep in touch with standards developments and receive substantial discounts on the purchase price of standards, both in single copy and subscription format, by becoming a **BSI Subscribing Member**.

**PLUS** is an updating service exclusive to BSI Subscribing Members. You will automatically receive the latest hard copy of your standards when they're revised or replaced.

To find out more about becoming a BSI Subscribing Member and the benefits of membership, please visit [bsigroup.com/shop](http://bsigroup.com/shop).

With a **Multi-User Network Licence (MUNL)** you are able to host standards publications on your intranet. Licences can cover as few or as many users as you wish. With updates supplied as soon as they're available, you can be sure your documentation is current. For further information, email [bsmusales@bsigroup.com](mailto:bsmusales@bsigroup.com).

## BSI Group Headquarters

389 Chiswick High Road London W4 4AL UK

## Revisions

Our British Standards and other publications are updated by amendment or revision.

We continually improve the quality of our products and services to benefit your business. If you find an inaccuracy or ambiguity within a British Standard or other BSI publication please inform the Knowledge Centre.

## Copyright

All the data, software and documentation set out in all British Standards and other BSI publications are the property of and copyrighted by BSI, or some person or entity that owns copyright in the information used (such as the international standardization bodies) and has formally licensed such information to BSI for commercial publication and use. Except as permitted under the Copyright, Designs and Patents Act 1988 no extract may be reproduced, stored in a retrieval system or transmitted in any form or by any means – electronic, photocopying, recording or otherwise – without prior written permission from BSI. Details and advice can be obtained from the Copyright & Licensing Department.

## Useful Contacts:

### Customer Services

**Tel:** +44 845 086 9001

**Email (orders):** [orders@bsigroup.com](mailto:orders@bsigroup.com)

**Email (enquiries):** [cservices@bsigroup.com](mailto:cservices@bsigroup.com)

### Subscriptions

**Tel:** +44 845 086 9001

**Email:** [subscriptions@bsigroup.com](mailto:subscriptions@bsigroup.com)

### Knowledge Centre

**Tel:** +44 20 8996 7004

**Email:** [knowledgecentre@bsigroup.com](mailto:knowledgecentre@bsigroup.com)

### Copyright & Licensing

**Tel:** +44 20 8996 7070

**Email:** [copyright@bsigroup.com](mailto:copyright@bsigroup.com)



...making excellence a habit.™