

BS ISO 15830-2:2013



BSI Standards Publication

# Road vehicles — Design and performance specifications for the WorldSID 50th percentile male side-impact dummy

Part 2: Mechanical subsystems

**bsi.**

...making excellence a habit.™

**National foreword**

This British Standard is the UK implementation of ISO 15830-2:2013. It supersedes BS ISO 15830-2:2005 which is withdrawn.

The UK participation in its preparation was entrusted to Technical Committee AUE/7, Automobile occupant restraint systems.

A list of organizations represented on this committee can be obtained on request to its secretary.

This publication does not purport to include all the necessary provisions of a contract. Users are responsible for its correct application.

© The British Standards Institution 2013. Published by BSI Standards Limited 2013

ISBN 978 0 580 76324 3

ICS 43.020

**Compliance with a British Standard cannot confer immunity from legal obligations.**

This British Standard was published under the authority of the Standards Policy and Strategy Committee on 31 July 2013.

**Amendments issued since publication**

Date	Text affected
------	---------------

---

INTERNATIONAL  
STANDARD

**ISO**  
**15830-2**

Second edition  
2013-05-15

---

---

**Road vehicles — Design and  
performance specifications for the  
WorldSID 50th percentile male side-  
impact dummy —**

**Part 2:  
Mechanical subsystems**

*Véhicules routiers — Conception et spécifications de performance  
pour le mannequin mondial (WorldSID), 50e percentile homme, de  
choc latéral —*

*Partie 2: Sous-systèmes mécaniques*



Reference number  
ISO 15830-2:2013(E)

© ISO 2013



**COPYRIGHT PROTECTED DOCUMENT**

© ISO 2013

All rights reserved. Unless otherwise specified, no part of this publication may be reproduced or utilized otherwise in any form or by any means, electronic or mechanical, including photocopying, or posting on the internet or an intranet, without prior written permission. Permission can be requested from either ISO at the address below or ISO's member body in the country of the requester.

ISO copyright office  
Case postale 56 • CH-1211 Geneva 20  
Tel. + 41 22 749 01 11  
Fax + 41 22 749 09 47  
E-mail [copyright@iso.org](mailto:copyright@iso.org)  
Web [www.iso.org](http://www.iso.org)

Published in Switzerland

# Contents

Page

<b>Foreword</b> .....	<b>iv</b>
<b>Introduction</b> .....	<b>v</b>
<b>1 Scope</b> .....	<b>1</b>
<b>2 Normative references</b> .....	<b>1</b>
<b>3 Terms and definitions</b> .....	<b>1</b>
<b>4 Mechanical requirements for WorldSID</b> .....	<b>2</b>
4.1 Head.....	2
4.2 Neck.....	3
4.3 Thorax/abdomen/shoulder.....	4
4.4 Full arms.....	5
4.5 Half arms.....	6
4.6 Lumbar spine and pelvis.....	6
4.7 Upper legs.....	7
4.8 Lower leg, ankle, and foot.....	7
4.9 Clothing.....	7
4.10 Whole dummy.....	8
<b>5 Validation test procedures</b> .....	<b>8</b>
5.1 Head.....	8
5.2 Neck.....	11
5.3 Thorax/abdomen/shoulder/pelvis full body tests.....	13
5.4 Data zero values.....	23
<b>Annex A (normative) Support equipment</b> .....	<b>24</b>
<b>Annex B (normative) Drawings and specifications, PDF, and STP files</b> .....	<b>26</b>
<b>Annex C (informative) Drawing list</b> .....	<b>27</b>

## Foreword

ISO (the International Organization for Standardization) is a worldwide federation of national standards bodies (ISO member bodies). The work of preparing International Standards is normally carried out through ISO technical committees. Each member body interested in a subject for which a technical committee has been established has the right to be represented on that committee. International organizations, governmental and non-governmental, in liaison with ISO, also take part in the work. ISO collaborates closely with the International Electrotechnical Commission (IEC) on all matters of electrotechnical standardization.

The procedures used to develop this document and those intended for its further maintenance are described in the ISO/IEC Directives, Part 1. In particular the different approval criteria needed for the different types of ISO documents should be noted. This document was drafted in accordance with the editorial rules of the ISO/IEC Directives, Part 2. [www.iso.org/directives](http://www.iso.org/directives)

Attention is drawn to the possibility that some of the elements of this document may be the subject of patent rights. ISO shall not be held responsible for identifying any or all such patent rights. Details of any patent rights identified during the development of the document will be in the Introduction and/or on the ISO list of patent declarations received. [www.iso.org/patents](http://www.iso.org/patents)

Any trade name used in this document is information given for the convenience of users and does not constitute an endorsement.

The committee responsible for this document is ISO/TC 22, *Road vehicles*, Subcommittee SC 12, *Passive safety crash protection systems*.

This second edition cancels and replaces the first edition (ISO 15830-2:2005) which has been technically revised. Technical amendments have been incorporated throughout all four parts, resulting from extensive experience with the standard and design changes.

ISO 15830 consists of the following parts, under the general title *Road vehicles — Design and performance specifications for the WorldSID 50th percentile male side impact dummy*:

- *Part 1: Terminology and rationale*
- *Part 2: Mechanical subsystems*
- *Part 3: Electronic subsystems*
- *Part 4: User's manual*

## Introduction

This second edition of ISO 15830 has been prepared on the basis of the existing design, specifications, and performance of the WorldSID 50th percentile adult male side-impact dummy. The purpose of the ISO 15830 series is to document the design and specifications of this side-impact dummy in a form suitable and intended for worldwide regulatory use.

In 1997, ISO/TC22/SC12 initiated the WorldSID 50th percentile adult male dummy development, with the aims of defining a global-consensus side-impact dummy, having a wider range of humanlike anthropometry, biofidelity, and injury monitoring capabilities, suitable for regulatory use. Participating in the development were research institutes, dummy and instrumentation manufacturers, governments, and vehicle manufacturers from around the world.

With regard to potential regulatory, consumer information, or research and development use of ISO 15830, users will need to identify which of the permissive (i.e. optional) sensors and other elements defined in ISO 15830-3 are to be used in a given application.

WorldSID drawings in electronic format are being made available. Details are given in ISO 15830-2:2013, [Annex B](#).

In order to apply ISO 15830 properly, it is important that all four parts be used together.





# Road vehicles — Design and performance specifications for the WorldSID 50th percentile male side-impact dummy —

## Part 2: Mechanical subsystems

### 1 Scope

This part of ISO 15830 specifies requirements for mechanical components, drawings and specifications, validation tests, and support equipment for the WorldSID 50th percentile side-impact dummy, a standardized anthropomorphic dummy for side-impact testing of road vehicles. It is applicable to impact tests involving

- passenger vehicles of category M<sub>1</sub> and goods vehicles of category N<sub>1</sub>,
- impacts to the side of the vehicle structure, and
- impact tests involving use of an anthropomorphic dummy as a human surrogate for the purpose of evaluating compliance with vehicle safety standards.

### 2 Normative references

The following documents, in whole or in part, are normatively referenced in this document and are indispensable for its application. For dated references, only the edition cited applies. For undated references, the latest edition of the referenced document (including any amendments) applies.

ISO 6487, *Road vehicles — Measurement techniques in impact tests — Instrumentation*

ISO 15830-1, *Design and performance specifications for the WorldSID 50th percentile adult male side impact dummy — Part 1: Terminology and rationale*

ISO 15830-3:2013, *Design and performance specifications for the WorldSID 50th percentile adult male side-impact dummy — Part 3: Electronic subsystems*

ISO 15830-4, *Design and performance specifications for the WorldSID 50th percentile adult male side-impact dummy — Part 4: User's manual*

SAE J211-1:2007, *Instrumentation for impact test — Part 1: Electronic instrumentation*

SAE J2570:2001, *Performance specifications for anthropomorphic test device transducers*

49 CFR Part 572, subpart E, *Anthropomorphic test dummies, United States of America Code of Federal Regulations issued by the National Highway Traffic Safety Administration (NHTSA). Washington, DC, US*

### 3 Terms and definitions

For the purposes of this document, the terms and definitions given in ISO 15830-1 apply.

## 4 Mechanical requirements for WorldSID

### 4.1 Head

#### 4.1.1 General description

The head assembly shall consist of the components and assemblies listed in head assembly drawing W50-10000.pdf (see [Annex B](#)).

#### 4.1.2 Drawings and specifications

- The head assembly and components shall conform to head assembly drawing W50-10000.pdf (see [Annex B](#)) and the subassembly and component drawings listed therein.
- The total assembly shall have a mass of  $4,22 \text{ kg} \pm 0,05 \text{ kg}$ .
- The centre of gravity shall be located as indicated in [Figure 1](#).
- The materials used in the construction of the head assembly shall not contain lead or lead alloys.
- The flesh material and/or external surface characteristics shall enable positive attachment of adhesive targets.
- If present, cables exiting the head assembly shall exit at the rear and include a secure strain relief mechanism.

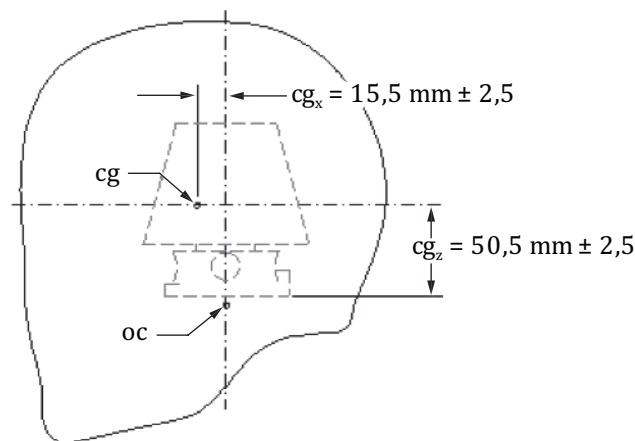

Figure 1 — Head centre of gravity location

#### 4.1.3 Validation

When assembled according to ISO 15830-4, and tested using the procedure specified in [5.1](#), the head assembly shall meet the specifications given in [Table 1](#).

**Table 1 — WorldSID head validation specifications**

Frontal drop	
Variable	Absolute value
Peak resultant acceleration (G)	225 to 275
Peak lateral acceleration ( $a_y$ ) (G)	<15
Maximum percentage, subsequent-to-main peak (%)	<10
Lateral drop	
Variable	Absolute value
Peak resultant acceleration at CG (G)	99 to 121
Peak longitudinal acceleration ( $a_x$ ) (G)	<15
Maximum percentage, subsequent-to-main peak (%)	<10

## 4.2 Neck

### 4.2.1 General description

The neck assembly shall consist of the components and assemblies listed in neck assembly drawing W50-20000.pdf (see [Annex B](#)).

### 4.2.2 Drawings and specifications

- The neck assembly and components shall conform to neck assembly drawing W50-20000.pdf (see [Annex B](#)) and the subassembly and component drawings listed therein.
- The total assembly shall have a mass of 2,84 kg ± 0,15 kg.
- The materials used in the construction of the neck assembly shall not contain lead or lead alloys.
- The flesh material and/or external surface characteristics shall enable positive attachment of adhesive targets.
- If present, cables exiting the neck assembly shall include a secure strain relief mechanism.

### 4.2.3 Validation

When assembled according to ISO 15830-4, and tested using the procedure specified in [5.2](#), the neck assembly shall meet the specifications given in [Table 2](#).

**Table 2 — WorldSID neck validation specifications**

Variable	Absolute value
Maximum angular displacement of the head form relative to the pendulum, $\beta$ (degrees)	50 to 61
Decay time of $\beta$ to 0 degrees (ms)	58 to 72
Peak moment at occipital condyle (Nm)	55 to 68
Peak moment decay time to 0 Nm (ms) <sup>a</sup>	71 to 87
Peak forward potentiometer angular displacement (degrees)	32 to 39
Time of peak forward potentiometer angular displacement (ms) <sup>a</sup>	56 to 68
Peak rearward potentiometer angular displacement, $\theta_F$ (degrees)	30 to 37

**Table 2** (continued)

Variable	Absolute value
Time of peak rearward potentiometer angular displacement, $\theta_R$ (ms) <sup>a</sup>	56 to 68
<sup>a</sup> T=0 s at initial pendulum contact with honeycomb or alternative products which can be shown to lead to the same results.	

### 4.3 Thorax/abdomen/shoulder

#### 4.3.1 General description

The thorax/abdomen/shoulder assembly shall consist of the components and assemblies listed in thorax/abdomen/shoulder assembly drawing W50-30000.pdf (see [Annex B](#)).

#### 4.3.2 Drawings and specifications

- The thorax/abdomen/shoulder assembly and components shall conform to thorax/abdomen/shoulder assembly drawing W50-30000.pdf (see [Annex B](#)) and the subassembly and component drawings listed therein.
- The total assembly shall have a mass of 20,55 kg ± 1,0 kg.
- The materials used in the construction of the thorax/abdomen/shoulder assembly shall not contain lead or lead alloys.
- The flesh material and/or external surface characteristics shall enable positive attachment of adhesive targets.
- If present, cables exiting the thorax/abdomen/shoulder assembly shall include a secure strain relief mechanism.

#### 4.3.3 Validation

##### 4.3.3.1 Shoulder

When assembled according to ISO 15830-4, and tested using the procedure specified in [5.3.1](#) and [5.3.2](#), the shoulder assembly shall meet the specifications given in [Table 3](#).

**Table 3 — WorldSID shoulder validation specifications**

Variable	Absolute value
Peak pendulum force (kN)	2,6 to 3,3
Peak shoulder rib deflection (mm)	35 to 44

##### 4.3.3.2 Thorax with half arm

When assembled according to ISO 15830-4, and tested using the procedure specified in [5.3.1](#) and [5.3.3](#), the thorax with half-arm assembly shall meet the specifications given in [Table 4](#).

**Table 4 — WorldSID thorax with half-arm validation specifications**

Variable	Absolute value
Peak pendulum force (kN)	4,9 to 5,8
Peak T4 acceleration along y axis (G)	28 to 37
Peak T12 acceleration along y axis (G)	22 to 28
Peak thorax rib 1 deflection (mm)	35 to 47
Peak thorax rib 2 deflection (mm)	46 to 56
Peak thorax rib 3 deflection (mm)	39 to 46

#### 4.3.3.3 Thorax without arm

When assembled according to ISO 15830-4, and tested using the procedure specified in [5.3.1](#) and [5.3.4](#), the thorax without arm assembly shall meet the specifications given in [Table 5](#).

**Table 5 — WorldSID thorax without arm validation specifications**

Variable	Absolute value
Peak pendulum force (kN)	3,2 to 3,8
Peak T4 acceleration along y axis (G)	14 to 20
Peak T12 acceleration along y axis (G)	14 to 22
Peak thorax rib 1 deflection (mm)	33 to 43
Peak thorax rib 2 deflection (mm)	35 to 43
Peak thorax rib 3 deflection (mm)	32 to 40

#### 4.3.3.4 Abdomen

When assembled according to ISO 15830-4, and tested using the procedure specified in [5.3.1](#) and [5.3.5](#), the abdomen without arm assembly shall meet the specifications given in [Table 6](#).

**Table 6 — WorldSID abdomen validation specifications**

Variable	Absolute value
Peak pendulum force (kN)	2,7 to 3,1
Peak T12 acceleration along y axis (G)	15 to 20
Peak abdomen rib 1 deflection (mm)	33 to 40
Peak abdomen rib 2 deflection (mm)	30 to 36

### 4.4 Full arms

#### 4.4.1 General description

The full arm assembly may be installed on either side of the dummy. If installed, it shall consist of the components and assemblies listed in full arm assembly drawings W50-61000.pdf (left) and W50-61001.pdf (right) (see [Annex B](#)).

#### 4.4.2 Drawings and specifications

- The full arm assembly and components shall conform to full arm assembly drawings W50-61000.pdf (left) and W50-61001.pdf (right) (see [Annex B](#)) and the subassemblies and component drawings listed therein.

- The total assembly shall have a mass of 3,72 kg ± 0,15 kg.
- The materials used in the construction of the full arm assembly shall not contain lead or lead alloys.
- The flesh material and/or external surface characteristics shall enable positive attachment of adhesive targets.
- If present, cables exiting the full arm assembly shall include a secure strain relief mechanism.

## 4.5 Half arms

### 4.5.1 General description

The half arm assembly shall consist of the components and assemblies listed in half arm assembly W50-62000.pdf (see [Annex B](#)).

### 4.5.2 Drawings and specifications

- The half arm assembly shall conform to half arm assembly drawing W50-62000.pdf (see [Annex B](#)) and the subassemblies and component drawings listed therein.
- The total assembly shall have a mass of 1,77 kg ± 0,09 kg.
- The materials used in the construction of the half arm assembly shall not contain lead or lead alloys.
- The flesh material and/or external surface characteristics shall enable positive attachment of adhesive targets.

## 4.6 Lumbar spine and pelvis

### 4.6.1 General description

The lumbar spine and pelvis assembly shall consist of the components and assemblies listed in lumbar spine and pelvis assembly drawing W50-40000.pdf (see [Annex B](#)).

### 4.6.2 Drawings and specifications

- The lumbar spine and pelvis assembly shall conform to lumbar spine and pelvis assembly drawing W50-40000.pdf (see [Annex B](#)) and the subassemblies and component drawings listed therein.
- The total assembly shall have a mass of 17,75 kg ± 0,90 kg.
- The materials used in the construction of the pelvis assembly shall not contain lead or lead alloys.
- The flesh material and/or external surface characteristics shall enable positive attachment of adhesive targets.
- If present, cables exiting the pelvis assembly shall include a secure strain relief mechanism.

### 4.6.3 Validation

When assembled according to ISO 15830-4, and tested using the procedure specified in [5.3.1](#) and [5.3.6](#), the pelvis assembly shall meet the specifications given in [Table 7](#).

**Table 7 — WorldSID pelvis validation specifications**

Variable	Absolute value
Peak pelvis acceleration along y axis (G)	41 to 51
Peak pendulum force (kN)	6,3 to 7,8
Peak T12 acceleration along y axis (G)	10 to 14

## 4.7 Upper legs

### 4.7.1 General description

The upper leg assembly shall consist of the components and assemblies listed in upper leg assembly drawings W50-51000.pdf (right) and W50-51050.pdf (left) (see [Annex B](#)).

### 4.7.2 Drawings and specifications

- The upper leg assembly and components shall conform to upper leg drawings W50-51000.pdf (right) and W50-51050.pdf (left) (see [Annex B](#)) and the subassemblies and component drawings listed therein.
- The total assembly shall have a mass of 6,71 kg ± 0,30 kg.
- The materials used in the construction of the upper leg assembly shall not contain lead or lead alloys.
- The flesh material and/or external surface characteristics shall enable positive attachment of adhesive targets.
- If present, cables exiting the upper leg assembly shall include a secure strain relief mechanism.

## 4.8 Lower leg, ankle, and foot

### 4.8.1 General description

The lower leg, ankle, and foot assembly shall consist of the components and assemblies listed in lower leg, ankle, and foot assembly drawing W50-54054.pdf (right) and W50-54056.pdf (left) (see [Annex B](#)).

### 4.8.2 Drawings and specifications

- The lower leg assembly shall conform to lower leg, ankle, and foot assembly drawing W50-54054.pdf (right) and W50-54055.pdf (left) (see [Annex B](#)) and the subassemblies and component drawings listed therein.
- The total assembly shall have a mass of 5,09 kg ± 0,13 kg.
- The materials used in the construction of the lower leg assembly shall not contain lead or lead alloys.
- The flesh material and/or external surface characteristics shall enable positive attachment of adhesive targets.
- If present, cables exiting the lower leg assembly shall include a secure strain relief mechanism.

## 4.9 Clothing

### 4.9.1 General description

The clothing shall consist of the components and assemblies listed in clothing assembly drawing W50-80100.pdf (see [Annex B](#)).

#### 4.9.2 Drawings and specifications

- The clothing shall conform to clothing assembly drawing W50-80100.pdf (see [Annex B](#)) and the subassemblies and component drawings listed therein.
- The total assembly shall have a mass of 1,85 kg ± 0,09 kg.
- The materials used in the construction of the clothing shall not contain lead or lead alloys.
- The external surface characteristics shall enable positive attachment of adhesive targets.

#### 4.10 Whole dummy

- The total dummy assembly including clothing shall have a mass of 74,35 kg ± 3,74 kg.

### 5 Validation test procedures

#### 5.1 Head

##### 5.1.1 Principle

Certify the dynamic response of a head assembly by performing a 200 mm lateral drop on each side of the head and a 376 mm drop on the forehead.

##### 5.1.2 Apparatus

- 49 CFR Part 572, Subpart E, horizontal head impact surface
  - Chrome-plated rigidly supported horizontal steel plate
  - 50,8 mm x 610 mm x 610 mm
  - 8 – 80 rms micron/mm surface finish
- Head drop tool assembly (drawing W50-82100.pdf) (see [Annex B](#))
- Instrumented head assembly (drawing W50-10000.pdf) (see [Annex B](#)) including the instrumentation insert and upper neck load cell or structural replacement
- Two SHCS M6 × 12

##### 5.1.3 Sensors

Use tri-axial linear accelerometers as described in ISO 15830-3:2013, 4.1.3.2.

##### 5.1.4 Preparation

- Expose the head assembly to an environment with a temperature of 21,4 °C ± 0,8 °C and a relative humidity between 10 % and 70 % for a period of at least four hours prior to a test.
- Clean the head skin surface and the surface of the impact plate with 1,1,1 trichlorethane, isopropyl alcohol, or equivalent.
- Install the tri-axial accelerometer in the head assembly.
- Install the upper neck load cell, angular accelerometers and dual-axis tilt sensor, or their structural or mass replacements.
- Attach the head drop tool to the bottom of the upper neck load cell or its structural replacement with the two SHCS M6x12. Mount the tool for left or right lateral, or frontal drops as shown in [Figures 2](#),



3, 4, and 5. When mounted for lateral drops, position the head such that its midsagittal plane has an angle of  $35^\circ \pm 1^\circ$  with the impact surface and its anterior-posterior axis is horizontal to within  $1^\circ$ .

- Suspend the head above the drop table using the head drop tool and a quick release mechanism.
- For lateral tests, position the head so its lowest point is  $200 \text{ mm} \pm 0,25 \text{ mm}$  above the impact surface and drop the head.

For a frontal test, position the head so the lowest point on the forehead is  $376 \text{ mm} \pm 0,25 \text{ mm}$  above the impact surface.

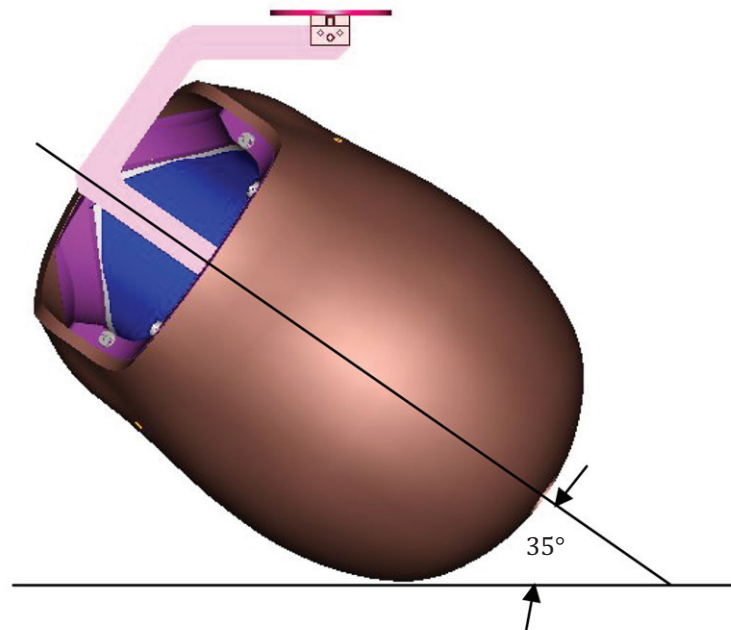

Figure 2 — Lateral head drop angle

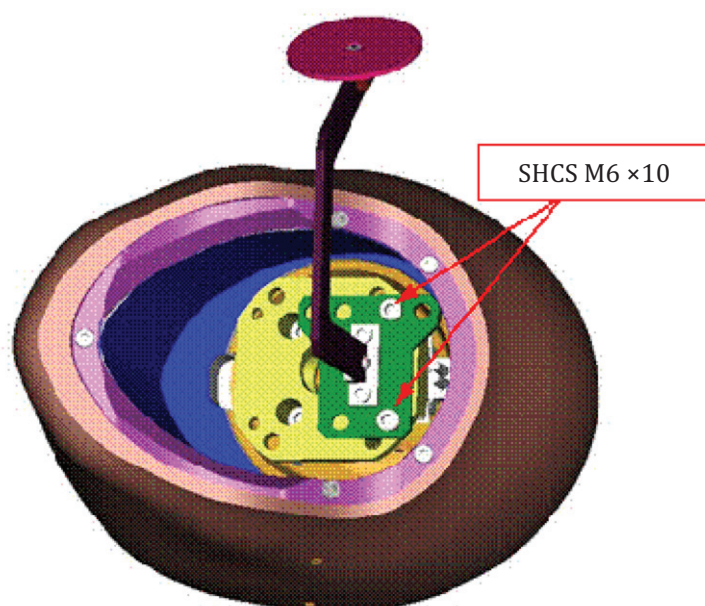

Figure 3 — Head bracket installation for lateral drops

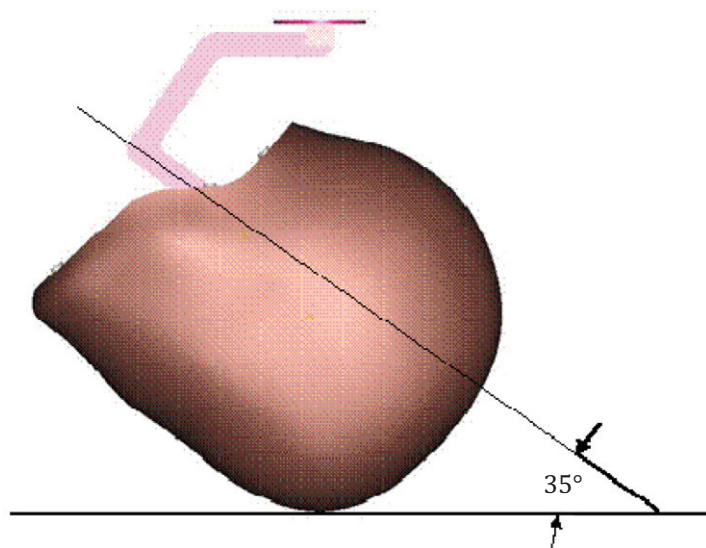

Figure 4 — Frontal head drop angle

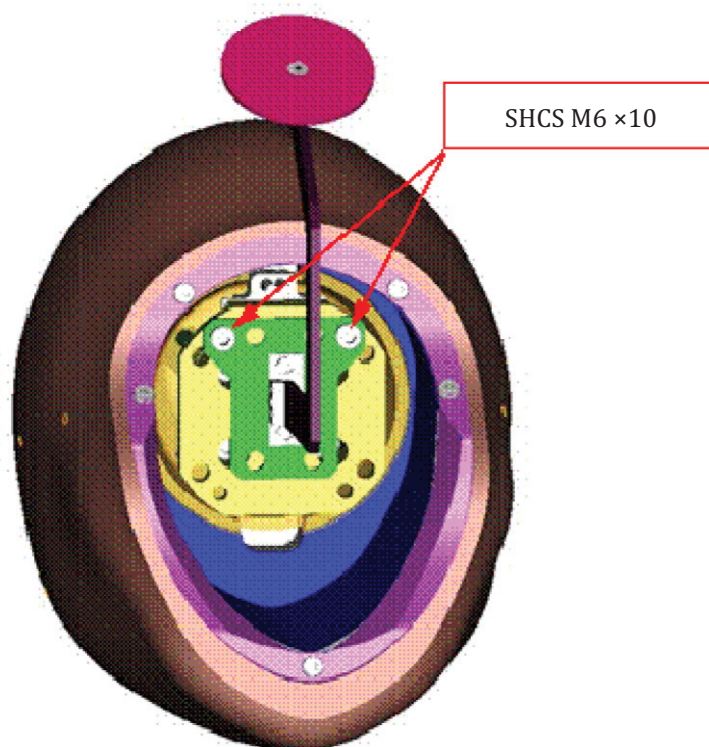

Figure 5 — Head bracket installation for frontal drops

#### 5.1.5 Procedure

- Record and filter the head accelerations from the tri-axial accelerometer according to SAE J211 and ISO 6487 Channel filter class 1000.
- Drop the head onto the rigid plate from the specified height by means that ensure quick release.
- Visually inspect the head for damage to the skin or skull, and note any such damage in the test report.

— Allow at least 2 h between successive tests on the same head.

### 5.1.6 Test report

Document the results of both the left and right lateral and the frontal drop tests.

## 5.2 Neck

### 5.2.1 Principle

Certify the dynamic response of the neck assembly by performing lateral pendulum tests.

### 5.2.2 Materials

For the pendulum stop, use aluminium honeycomb, of density  $28,8 \text{ kg/m}^3 \pm 4,90 \text{ kg/m}^3$  and dimensions 102,0 mm minimum x 102,0 mm minimum with a thickness along the cells of  $76,2 \text{ mm} \pm 4 \text{ mm}$  or alternative products which can be shown to lead to the same results.

### 5.2.3 Apparatus

- Neck assembly as specified in [4.2.1](#)
- WorldSID head form (drawing W50-83000.pdf) (see [Annex B](#))
- Neck pendulum apparatus as specified in 49 CFR Part 572, Subpart E

### 5.2.4 Sensors

Perform the test using the sensors given in [Table 8](#).

**Table 8 — Sensors for neck assembly**

Variable	Sensor	Performance
Pendulum acceleration	Single axis accelerometer Endevco 7231C-750 <sup>a</sup>	SAE J2570
Pendulum velocity	Not specified	Resolution 0,02 m/s or better
Angular displacement of forward pendulum-to-head form sliding rod, positive when doing a right side impact ( $\theta_F$ )	Angular potentiometer	SAE J2570
Angular displacement of rearward pendulum-to-head form sliding rod, positive when doing a right side impact ( $\theta_R$ )	Angular potentiometer	SAE J2570
Angular displacement of head form about forward pendulum-to-head form sliding rod, positive when doing a right side impact ( $\theta_H$ )	Angular potentiometer	SAE J2570
Neck moment, $M_x$	Upper neck load cell ISO 15830-3:2013, 4.1.3.5	SAE J2570
Neck force, $F_y$	Upper neck load cell ISO 15830-3:2013, 4.1.3.5	SAE J2570

<sup>a</sup> Accelerometer model 7231C-750 is a product supplied by Endevco Corp. San Juan Capistrano, California, USA. This information is given for the convenience of users of this International Standard and does not constitute an endorsement by ISO of the product named. Alternative products may be used if they can be shown to lead to the same results.

### 5.2.5 Preparation

Expose the neck to the conditions specified in [Table 9](#) for at least four hours prior to a test.

**Table 9 — Neck test preconditions**

Variable	Specification
Temperature (° C)	21,4 ± 0,8
Relative humidity (%)	40 ± 30

- Attach the top of the neck to the head form.
- Attach the bottom of the neck to the pendulum interface. Ensure that the screws do not protrude into the neck rubber as this may influence the response. If the screws are too long, insert washers under the head of the screw in order to prevent rubber contact. Mount the pendulum interface to the pendulum such that the head form's midsagittal plane is vertical and is perpendicular to the plane of motion of the pendulum's longitudinal centreline.
- Slide the carbon fibre rods through the potentiometer housings on the pendulum. First, slide the pivot of the potentiometer closest to the pendulum over the central steel rod in the head form, then install the small spacer ring and the second pivot. Carefully tighten the second pivot.

### 5.2.6 Procedure

- Record and filter the data according to ISO 6487 or SAE J211 Channel filter class 1000.
- Release the pendulum and allow it to fall freely from a height such that the velocity at impact is 3,4 m/s ± 0,1 m/s, measured at the centre of the pendulum-mounted accelerometer.
- Decelerate the pendulum arm using the 28,8 kg/m<sup>3</sup> aluminium honeycomb or alternative products which can be shown to lead to the same results, to achieve the pendulum pulse given in [Table 10](#).
- Allow the neck to flex without impact of the head or neck with any object other than the pendulum arm.
- Conduct the test such that the time between raising the pendulum and releasing it does not exceed 5 minutes.
- Conduct the test such that the time between any tests on the same WorldSID neck is not less than 30 minutes.

**Table 10 — Pendulum arm deceleration pulse**

Variable	Value
Velocity change at 4 ms <sup>a</sup>	0,8m/s to 1,0 m/s
Velocity change at 8 ms <sup>a</sup>	1,60 m/s to 1,9 m/s
Velocity change at 12 ms <sup>a</sup>	2,4 m/s to 3,3 m/s
<sup>a</sup> T=0 s at initial contact with honeycomb or alternative products which can be shown to lead to the same results.	

### 5.2.7 Calculation procedures

- Filter the data according to ISO 6487 or SAE J211, as given in [Table 11](#).
- Integrate the filtered and adjusted acceleration time histories.
- Calculate the flexion angle of the head form using the following formula:

$$\beta = \theta_F + \theta_H \quad (1)$$

where

- $\beta$  is the angular displacement of head form relative to the pendulum;
- $\theta_F$  is the angular displacement of forward pendulum-to-head form sliding rod, positive when doing a right side impact;
- $\theta_H$  is the lateral angular displacement of head form about forward pendulum-to-head form sliding rod, positive when doing a right side impact.

- After performing this calculation, digitally filter all angular displacements using ISO 6487 or SAE J211 CFC 180.
- Calculate the moment about the occipital condyle as  $M_{OCx} = M_x + (F_y) \times (0,019\ 5\ \text{m})$ , where the  $M_x$  and  $F_y$  polarities are in accordance with the SAE J211 sign convention.

**Table 11 — Filter specification for neck test**

Variable	Filters <sup>a</sup>
Pendulum acceleration	CFC 60
Pendulum velocity	No digital filtering
Angular displacement of forward rod ( $\theta_F$ )	CFC 1000
Angular displacement rear rod ( $\theta_R$ )	CFC 1000
Angular displacement of head form ( $\theta_H$ )	CFC 1000
Neck moment, $M_x$	CFC 600
Neck force, $F_y$	CFC 1000
<sup>a</sup> ISO 6487 or SAE J211	

### 5.2.8 Test reports

Document the results of the test.

## 5.3 Thorax/abdomen/shoulder/pelvis full body tests

### 5.3.1 Full body test setup

#### 5.3.1.1 Materials

Use Polytetrafluoroethylene (PTFE)<sup>1)</sup> sheets of sufficient size to cover seat.

#### 5.3.1.2 Apparatus

- H-Point tool (drawing W50-82500.pdf) (see [Annex B](#))
- Tilt sensor or inclinometer
- Dummy validation test bench
- Seat and back Polytetrafluoroethylene (PTFE)<sup>®</sup> sheets described in A.1

1) Teflon<sup>®</sup> is a commercial product. This information is given for the convenience of users of this International Standard and does not constitute an endorsement of the product named. Alternative products may be used if they can be shown to lead to the same results.

### 5.3.1.3 Preparation

Expose the dummy, clothed in its suit, to the conditions given in [Table 12](#) for at least four hours prior to a test.

**Table 12 — Dummy full body test preconditions**

Variable	Value
Temperature (° C)	21,4 ± 0,8
Relative humidity (%)	40 ± 30

### 5.3.1.4 Setup procedure

- Install the H-point tool.
- Install dual axis tilt sensors in the head, thorax, and pelvis to check the angles about x and y direction.
- Cover the seat back and base with Polytetrafluoroethylene (PTFE)® sheets.
- Seat the dummy on the rigid seat as shown in [Figure 6](#) and [Figure 7](#).
- Place the dummy on the seat and position it using either mechanical measurements on a dummy component or tilt sensors to verify the positions. The relationship between mechanical angle measurements and the tilt sensors are given in [Table 13](#).
- Position the dummy according to the criteria given in [Table 14](#).

**Table 13 — Relationship between mechanical measurement indicators and the tilt sensors**

Location	Mechanical reference	Tilt sensor (angular displacement about the noted axis)
Head zero	Landmark on head is horizontal	X: 0°, Y: 0°
Thorax zero	Top of the lower neck bracket is horizontal	X: 0°, Y: 0°
Pelvis zero	X angle zero degree H-point tool oriented at 45° below horizontal (Y)	X: 0°, Y: 14,5°

**Table 14 — Dummy set up criteria**

Variable	Criteria	Sensor readings
Thorax angle	0° ± 2°	
Pelvic orientation	5° ± 2° <sup>a</sup>	This pelvic orientation is coincident with H-point tool at 40° ± 2° below horizontal, and a pelvic tilt sensor at 19,5° ± 2°
Distance between knee centres	279 mm ± 50 mm	

<sup>a</sup> Due to the low friction of the Polytetrafluoroethylene (PTFE)® pieces, the dummy is not able to sit at zero pelvis angle. Five degrees is an achievable angle on the test bench.



**Figure 6 — Front view of setup for full dummy validation tests**

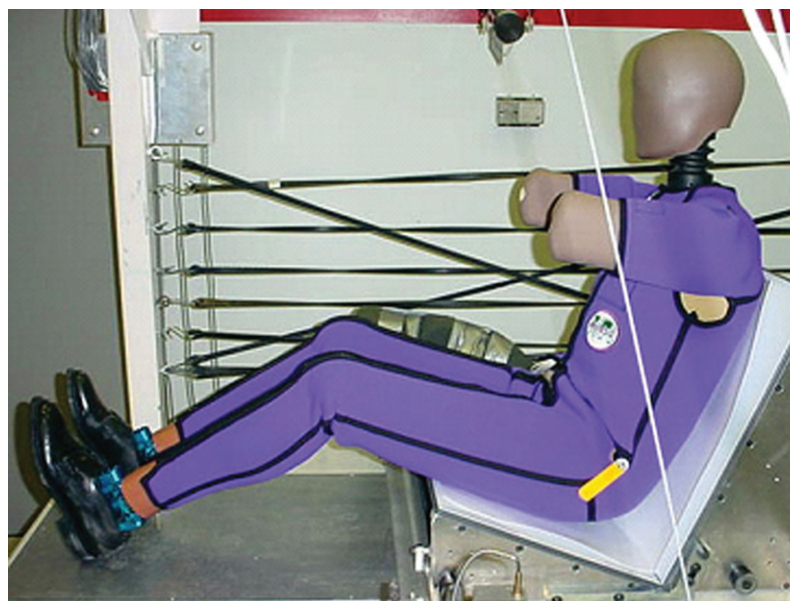

**Figure 7 — Side view of setup for full dummy validation tests**



Figure 8 — Using an inclinometer with the H-point tool to check pelvis angle

### 5.3.2 Shoulder test

#### 5.3.2.1 Principle

Perform a test involving a lateral impact to the shoulder in order to certify the dynamic response of the shoulders.

#### 5.3.2.2 Apparatus

Use 49 CFR Part 572, subpart E Hybrid III 50th percentile adult male dummy pendulum (23,4 kg, 152,4 mm face diameter).

#### 5.3.2.3 Sensors

Install instrumentation to obtain data for the items given in [Table 15](#).

Table 15 — Sensors for shoulder test

Variable	Sensor	Performance
Peak pendulum acceleration (G)	See <a href="#">Table 8</a>	Per SAE J2570
Peak shoulder rib deflection (mm)	IR-TRACC ISO 15830-3:2013, 4.1.3.6	See sensor specification details on electronic drawing number IF-363 (see <a href="#">Annex B</a> )
Impact velocity (m/s)	Not specified	Resolution 0,02 m/s or better

#### 5.3.2.4 Procedure

- Set up the dummy in standard test posture as described in [5.3.1](#) with the half arm aligned horizontal on the impact side as shown in [Figure 9](#).



- Align the pendulum centreline with the centreline of the shoulder y-axis rotation point.
- Raise the pendulum to achieve a  $4,3 \text{ m/s} \pm 0,1 \text{ m/s}$  impact velocity.
- Release the pendulum to impact the dummy.



**Figure 9 — Shoulder test, dummy and arm position**

#### 5.3.2.5 Calculation procedures and expression of results

- Filter the data according to ISO 6487 or SAE J211, as given in [Table 16](#).
- Calculate the pendulum impactor force by multiplying the pendulum acceleration time history by the measured impactor mass.
- Graph the time histories of impactor force and shoulder deflection.

**Table 16 — Filter specifications for shoulder test**

Variable	Filter
Pendulum acceleration (G)	CFC 180
Shoulder deflection (mm)	CFC 600

#### 5.3.2.6 Test reports

Document the results of the test.

### 5.3.3 Thorax with half arm

#### 5.3.3.1 Principle

Perform a test involving a lateral impact to the thorax with the half arm in order to certify the dynamic response of the thorax.

### 5.3.3.2 Apparatus

Use 49 CFR Part 572, subpart E Hybrid III 50th percentile adult male dummy pendulum (23,4 kg, 152,4 mm face diameter).

### 5.3.3.3 Sensors

Install instrumentation in order to obtain data for the items given in [Table 17](#).

**Table 17 — Sensor specifications for thorax with half arm test**

Variable	Sensor	Performance
Peak pendulum acceleration (G)	See <a href="#">Table 8</a>	SAE J2570
Peak upper spine (T4) y-axis acceleration (G)	Tri-axial linear accelerometer ISO 15830-3:2013, 4.1.3.2	SAE J2570
Peak lower spine (T12) y-axis acceleration (G)	Tri-axial linear accelerometer ISO 15830-3:2013, 4.1.3.2	SAE J2570
First, second, and third thorax rib deflections (mm)	IR-TRACC ISO 15830-3:2013, 4.1.3.6	See sensor specification details on electronic drawing number IF-363 (see <a href="#">Annex B</a> )
Impact velocity (m/s)	Not specified	Resolution 0,02 m/s or better

### 5.3.3.4 Procedure

- Set up the dummy in standard test posture as described in [5.3.1](#) with the half arm parallel to the thorax.
- Align the pendulum centreline with the centreline of the middle thorax rib.
- Raise the pendulum to achieve a  $6,7 \text{ m/s} \pm 0,1 \text{ m/s}$  impact velocity.
- Release the pendulum to impact the dummy.

### 5.3.3.5 Calculation procedures and expression of results

- Filter the data according to ISO 6487 or SAE J211, as given in [Table 18](#).
- Calculate the pendulum impactor force by multiplying the pendulum acceleration time history by the measured impactor mass.
- Plot the time histories of impactor force, T4 and T12 y-axis accelerations, and deflections of thorax ribs 1, 2, and 3.

**Table 18 — Filter specifications for thorax with half arm test**

Variable	Filter
Peak pendulum acceleration (G)	CFC 180
Peak T4 y-axis acceleration (G)	CFC 180
Peak T12 y-axis acceleration (G)	CFC 180
Peak thorax rib 1 deflection (mm)	CFC 600
Peak thorax rib 2 deflection (mm)	CFC 600
Peak thorax rib 3 deflection (mm)	CFC 600

### 5.3.3.6 Test reports

Document the results of the test.

### 5.3.4 Thorax without arm

#### 5.3.4.1 Principle

Perform a test involving a lateral impact to the thorax without the arm in order to certify the dynamic response of the thorax.

#### 5.3.4.2 Apparatus

Use 49 CFR Part 572, subpart E Hybrid III 50th percentile adult male dummy pendulum (23,4 kg, 152,4 mm face diameter).

#### 5.3.4.3 Sensors

Install instrumentation to obtain data for the items given in [Table 19](#).

**Table 19 — Sensor specifications for thorax without arm test**

Variable	Sensor	Performance
Peak pendulum acceleration (G)	See <a href="#">Table 8</a>	SAE J2570
Peak upper spine (T4) y-axis acceleration (G)	Tri-axial linear acceleration ISO 15830-3:2013, 4.1.3.2	SAE J2570
Peak lower spine (T12) y-axis acceleration (G)	Tri-axial linear acceleration ISO 15830-3:2013, 4.1.3.2	SAE J2570
First, second, and third thorax rib deflections (mm)	IR-TRACC ISO 15830-3:2013, 4.1.3.6	See sensor specification details on electronic drawing number IF-363 (see <a href="#">Annex B</a> )
Impact velocity (m/s)	Not specified	Resolution 0,02 m/s or better

#### 5.3.4.4 Procedure

- Set up the dummy without arm in standard test posture as described in [5.3.1](#).
- Raise the arm to a vertical orientation as shown in [Figure 10](#).
- Align the pendulum centreline with the centreline of the middle thorax rib.
- Raise the pendulum to achieve a  $4,3 \text{ m/s} \pm 0,1 \text{ m/s}$  impact velocity.
- Release the pendulum to impact the dummy.

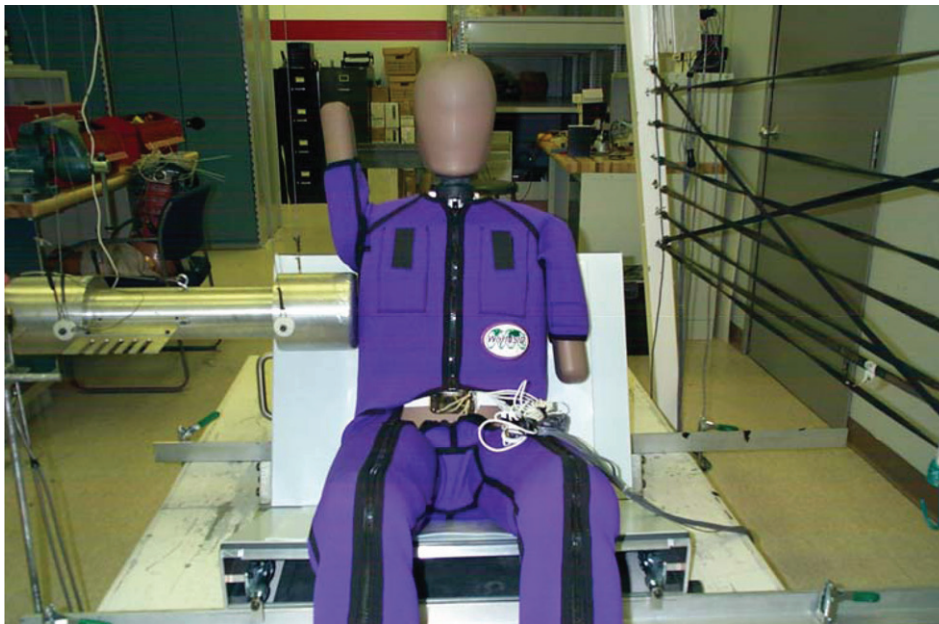

**Figure 10 — Thorax test without arm, dummy and arm position**

#### 5.3.4.5 Calculation procedures and expression of results

- Filter the data according to ISO 6487 or SAE J211, as given in [Table 20](#).
- Calculate the pendulum impactor force by multiplying the pendulum acceleration time history by the measured impactor mass.
- Graph the time histories of impactor force, T4 and T12 y-axis accelerations, and deflections of thorax ribs 1, 2, and 3.

**Table 20 — Filter specifications for thorax without half arm test**

Variable	Filter
Peak pendulum acceleration (G)	CFC 180
Peak T4 y-axis acceleration (G)	CFC 180
Peak T12 y-axis acceleration (G)	CFC 180
Peak thorax rib 1 deflection (mm)	CFC 600
Peak thorax rib 2 deflection (mm)	CFC 600
Peak thorax rib 3 deflection (mm)	CFC 600

#### 5.3.4.6 Test reports

Document the results of the test.

### 5.3.5 Abdomen test

#### 5.3.5.1 Principle

Perform a test involving a lateral impact to the abdomen in order to certify the dynamic response of the abdomen ribs.

### 5.3.5.2 Apparatus

Use the following items:

- 49 CFR Part 572, subpart E Hybrid III 50th percentile adult male pendulum (23,4 kg, 152,4 mm face diameter).
- Simulated armrest consisting of a rigid hardwood block as given in [Table 21](#) attached to the impact face of the pendulum. The centreline of the armrest simulator shall be aligned with the centreline of the pendulum.

**Table 21 — Simulated armrest specifications**

Variable	Value
Width (mm)	150 ± 0,5
Height (mm)	70 ± 0,5
Depth (mm)	60 ± 0,5
Corner radius (mm)	10 ± 1
Mass (kg)	1,00 ± 0,01

### 5.3.5.3 Sensors

Install instrumentation in order to obtain data for the items given in [Table 22](#).

**Table 22 — Sensor specifications for abdomen test**

Variable	Sensor	Performance
Pendulum acceleration (G)	See <a href="#">Table 8</a>	SAE J2570
Lower spine (T12) y-axis acceleration (G)	Tri-axial linear accelerometer ISO 15830-3:2013, 4.1.3.2	SAE J2570
Abdomen rib 1 and 2 deflections (mm)	IR-TRACC ISO 15830-3:2013, 4.1.3.6	See sensor specification details on electronic drawing number IF-363 (see <a href="#">Annex B</a> )
Impact velocity (m/s)	Not specified	Resolution 0,02 m/s or better

### 5.3.5.4 Procedure

- Set up the dummy in standard test posture as described in [5.3.1](#) with the half arm in the driving posture as shown in [Figure 6](#).
- Align the wood block face so it is aligned with and parallel to the middle of the two abdomen ribs.
- Place the wood block in contact with the side of the dummy.
- Raise the pendulum to achieve a 4,3 m/s ± 0,1 m/s impact velocity.
- Release the pendulum to impact the dummy.

### 5.3.5.5 Calculation procedures and expression of results

- Filter the data according to ISO 6487 or SAE J211-1, as given in [Table 23](#).
- Calculate the pendulum impactor force by multiplying the pendulum acceleration time history by the combined measured mass of the pendulum and armrest simulator.

- Graph the time histories of impactor force, T12 y-axis acceleration, and deflections of abdomen ribs 1 and 2.

**Table 23 — Filter specifications for abdomen test**

Variable	Filter
Pendulum acceleration (G)	CFC 180
T12 y-axis acceleration (G)	CFC 180
Abdomen rib 1 deflection (mm)	CFC 600
Abdomen rib 2 deflection (mm)	CFC 600

### 5.3.5.6 Test reports

Document the results of the abdomen test.

### 5.3.6 Pelvis test

#### 5.3.6.1 Principle

Perform a test involving a lateral impact to the pelvis in order to certify the dynamic response of the pelvis.

#### 5.3.6.2 Apparatus

Use 49 CFR Part 572, subpart E Hybrid III 50th percentile adult male dummy pendulum (23,4 kg, 152,4 mm face diameter).

#### 5.3.6.3 Sensors

Install instrumentation to obtain data for the items given in [Table 24](#).

**Table 24 — Sensor specifications for pelvis test**

Variable	Sensor	Performance
Pendulum acceleration (G)	See <a href="#">Table 8</a>	SAE J2570
Lower spine (T12) y-axis acceleration (G)	Tri-axial linear accelerometer ISO 15830-3:2013, 4.1.3.2	SAE J2570
Pelvis acceleration (G)	Tri-axial linear accelerometer ISO 15830-3:2013, 4.1.3.2	SAE J2570
Impact velocity (m/s)	Not specified	Resolution 0,02 m/s or better

#### 5.3.6.4 Procedure

- Set up the dummy with half arm in standard test posture as described in [5.3.1](#).
- Align the pendulum centreline with the H-point.
- Raise the pendulum to achieve a 6,7 m/s ± 0,1 m/s impact velocity.
- Release the pendulum to impact the dummy.

#### 5.3.6.5 Calculation procedures and expression of results

- Filter the data according to ISO 6487 or SAE J211-1, as given in [Table 25](#).

- Calculate the pendulum impactor force by multiplying the pendulum acceleration time history by the measured impactor mass.
- Graph the time histories of impactor force, pelvis, and T12 y-axis accelerations.

**Table 25 — Filter specifications for pelvis test**

Variable	Filter
Pendulum acceleration (G)	CFC 180
T12 y-axis acceleration (G)	CFC 180
Pelvis y-axis acceleration (G)	CFC 180

#### 5.3.6.6 Test reports

Document the results of the pelvis test.

#### 5.4 Data zero values

For all validation tests, set all data channels to a zero value at the time of initial contact of the moving component with the stationary component.

When using IR-TRACC sensors, due to the nonlinear input-output relationship, the voltage should be converted to engineering units before setting the data channel to zero as required above.

## Annex A (normative)

### Support equipment

#### A.1 Specialized WorldSID support equipment

Specialized WorldSID support equipment needed for WorldSID assembly, handling, or validation testing shall consist of the items given in [Table A.1](#).

**Table A.1 — Specialized WorldSID support equipment**

Reference	Description	Use	Part number <sup>b</sup>	Reference
5.1	Head drop tool	Validation	W50-82100	<a href="#">Annex B</a>
5.2	Head form	Validation	W50-83000	<a href="#">Annex B</a>
5.1	Head sensor extension cables for head drop test	Validation	Custom <sup>a</sup>	<a href="#">Annex B</a>
5.2	Head form rotational potentiometers, quantity of three	Validation	F_1A	
5.2	Carbon rods for potentiometers	Validation	F_GL	
5.2	Circular section neck buffers with different hardness	Validation	W50-20006	<a href="#">Annex B</a>
5.2	Neck and head form sensor extension cables for neck test	Validation	Custom <sup>a</sup>	
5.3	H-Point tool	Test setup	W50-82500	<a href="#">Annex B</a>
5.3	Polytetrafluoroethylene (PTFE)® covered dummy validation test bench	Validation	W50-82200	<a href="#">Annex B</a>
5.3	Small Polytetrafluoroethylene (PTFE)® sheets for the seat and back	Validation	W50-82244 W50-82245	<a href="#">Annex B</a>
	Modified spanner wrench, 25 mm to 28 mm dia.	Assembly	W50-51001	<a href="#">Annex B</a>
	Spanner wrench, 40 mm to 42 mm dia.	Assembly	W50-51002	<a href="#">Annex B</a>
	Modified hex key wrench	Assembly	W50-51003	<a href="#">Annex B</a>
	Modified 22 mm open-end wrench	Assembly	W50-51004	<a href="#">Annex B</a>
	Shortened 6 mm hex key 15 mm long	Assembly	W50-20018	<a href="#">Annex B</a>
	C-wrench for hip joint	Assembly	W50-42521	<a href="#">Annex B</a>
	Lifting mechanism	Handling	W50-84100 <sup>a</sup>	<a href="#">Annex B</a>
<sup>a</sup> This equipment may need to be customized for each lab.				
<sup>b</sup> Part numbers correspond to electronic drawing numbers (see <a href="#">Annex B</a> ).				

#### A.2 Other support equipment typically available in test laboratories

Other dummy support equipment needed for WorldSID validation and typically available in test laboratories shall be as given in [Table A.2](#).



**Table A.2 — Other standard support equipment**

<b>Reference</b>	<b>Description</b>	<b>Use</b>
5.1	49 CFR Part 572, Subpart E horizontal head impact surface	Validation
5.1	Quick release mechanism	Validation
5.2	49 CFR Part 572, Subpart E neck pendulum apparatus	Validation
5.2	49 CFR Part 572, Subpart E pendulum decelerating aluminium honeycomb or alternative products which can be shown to lead to the same results	Validation
5.2	Neck bending pendulum accelerometer, Endevco 7231C-750 <sup>a</sup>	Validation
5.3	49 CFR Part 572, subpart E Hybrid III 50th percentile adult male dummy pendulum (23,4 kg with 6 in. dia.)	Validation
5.3	49 CFR Part 572, subpart E Hybrid III 50th percentile adult male dummy pendulum accelerometer, Endevco 7231C-750 <sup>a</sup>	Validation
E.BF	Neck compression wrench	Assembly
<sup>a</sup> Accelerometer model 7231C-750 is a product supplied by Endevco Corporation, San Juan Capistrano, California, USA. This information is given for the convenience of users of this International Standard and does not constitute an endorsement by ISO of the product named. Alternative products may be used if they can be shown to lead to the same results.		

## **Annex B** (normative)

### **Drawings and specifications, PDF, and STP files**

The WorldSID shall be fabricated according to the drawings and specifications contained in the electronic PDF and STP files which may be obtained by contacting the WorldSID Task Group or ISO TC22/SC12/WG5.

## Annex C (informative)

### Drawing list

This annex lists the WorldSID drawings in [Table C.1](#) and fasteners in [Table C.2](#) for the convenience of users. The drawings are available electronically (see [Annex B](#)).

**Table C.1 — WorldSID drawing list**

Drawing number	Description	Electronic file format	
		PDF	STP
W50-00000	WorldSID ATD	×	
W50-10000	Head assembly, tested and certified	×	
W50-10007	Head core	×	
W50-10010	Rotational accelerometer replacement, Endevco 7302BM4	×	
W50-10011	Tilt sensor mass replacement	×	
W50-14014	Head, moulded, tested, and certified	×	×
W50-20000	Neck assembly	×	
W50-20002	Neck/head/torso interface plate	×	
W50-20006	Neck buffer assembly	×	
W50-20007	Screw, half spherical	×	
W50-20016	Flexion extension buffer	×	
W50-20018	Shortened 6 mm hex key	×	
W50-20101	Lower neck bracket	×	
W50-20102	Upper neck bracket	×	
W50-20103	Spacer nut	×	
W50-21001	Neck assembly, tested and certified	×	
W50-22003	Neck, moulded	×	×
W50-24013	Neck shroud assembly	×	
W50-24014	Neck shroud ring	×	×
W50-24015	Neck shroud	×	
W50-30000	Torso-shoulder thorax abdomen, WorldSID	×	
W50-31000	Spine box assembly	×	
W50-31010	Upper bracket weldment, spine box, WorldSID	×	
W50-31011	Shoulder mounting plate	×	
W50-31012	Middle plate	×	
W50-31013	Neck bracket mounting plate	×	
W50-31020	Side plate, left WorldSID	×	
W50-31030	Side plate, right WorldSID	×	
W50-31041	Spacer, WorldSID	×	
W50-31042	Mounting bracket #1	×	
W50-31043	Mounting bracket #2	×	

Table C.1 (continued)

Drawing number	Description	Electronic file format	
		PDF	STP
W50-31045	Cover plate spine box	×	
W50-31050	Ball joint assembly, IRTRACC	×	
W50-31051	Ball-shaft assembly	×	
W50-31053	Ball-shaft, IRTRACC	×	
W50-31054	Ball socket, IRTRACC	×	
W50-31055	Ball retainer, IRTRACC	×	
W50-31060	IR-TRACC mass replacement	×	
W50-32000	Rib, shoulder	×	
W50-32001	Rib assembly, shoulder	×	
W50-32010	Rib doubler, shoulder	×	
W50-32110	Thorax rib 1, WorldSID	×	
W50-32111	Thorax rib assembly, 1 WorldSID	×	
W50-32130	Thorax rib 2 and 3 abdominal ribs, WorldSID	×	
W50-32131	Thorax rib assembly, 2 and 3, WorldSID	×	
W50-32150-2	Thorax rib assembly, inner band, WorldSID	×	
W50-32151-2	Rib, damping	×	
W50-32152	Thorax rib bent, WorldSID	×	
W50-32155-2	Abdomen rib assembly, inner band, WorldSID	×	
W50-32156-2	Rib, damping	×	
W50-32160-2	Shoulder rib assembly, inner band, WorldSID	×	
W50-32161-2	Rib, damping	×	
W50-32162	Shoulder rib bent, WorldSID	×	
W50-32171	Shoulder rib mounting bracket, struck side, WorldSID	×	
W50-32172	Thorax and abdominal rib accelerometer mounting bracket, WorldSID	×	
W50-32173	Thorax and abdominal rib clamping bracket, WorldSID	×	
W50-32175	Shoulder rib sternum mounting strip, threaded	×	
W50-32176	Thorax and abdominal rib mounting strip, threaded	×	
W50-32177	Shoulder rib sternum mounting strip	×	
W50-32178	Thorax and abdominal rib sternum mounting strip	×	
W50-32179	Screw, rib IRTRACC mount	×	
W50-32180	Clamp, damping	×	
W50-35021	Rib coupler abdominal, WorldSID	×	×
W50-35022	Sternum, thorax rib	×	×
W50-35023-1	Shoulder pad, left, WorldSID	×	×
W50-35023-2	Shoulder pad, right, WorldSID	×	×
W50-35024	Pad, thorax	×	
W50-37013	Battery mount bracket	×	
W50-37014	Spine ballast stand offs	×	
W50-37015	G5 mounting bracket WorldSID thorax	×	

Table C.1 (continued)

Drawing number	Description	Electronic file format	
		PDF	STP
W50-37022	Backup plate mounting bracket	×	
W50-37023	Angular accelerometer, tilt sensor mount bracket	×	
W50-37024	T12 accelerometer mount, WorldSID	×	
W50-37029	Bracket, rotational accelerometer mount	×	
W50-40000	Pelvis assembly	×	
W50-41018	Lumbar spine rubber	×	×
W50-41019	Bushing lumbar	×	
W50-41020	Bushing, lumbar spine, top	×	
W50-41021	Lumbar lower clamping plate	×	
W50-41022	Lumbar upper clamping plate	×	
W50-41026	Lumbar mounting wedge	×	
W50-41030	Weldment lower lumbar mounting bracket	×	
W50-41031	Lower lumbar mounting bracket	×	
W50-41032	Dummy lifting socket	×	
W50-42002	Sacroiliac load cell backing plate	×	
W50-42005	Hip joint socket	×	
W50-42007	Inner ring hip joint	×	
W50-42008	Hip socket retainer	×	
W50-42010	Pelvis bone, left hand	×	×
W50-42011	Pelvis bone, right hand	×	×
W50-42012	Insert, iliac wing	×	
W50-42016	Sacroiliac load cell interface left hand	×	
W50-42017	Sacroiliac load cell interface right hand	×	
W50-42019	Pelvis flesh	×	×
W50-42031	Instrumentation cover plate, pelvis	×	
W50-42040	Instrumentation bracket pelvis	×	
W50-42510	Pubic buffer, moulded	×	
W50-42516	End plate medial	×	
W50-42517	End plate lateral	×	
W50-42521	C-wrench for hip joint	×	
W50-43001	Battery container	×	
W50-43002	Battery cover	×	
W50-51000	Upper leg assembly, right	×	
W50-51001	Modification of small spanner wrench (25 mm–28 mm)	×	
W50-51002	Unmodified large spanner wrench (40 mm–42 mm)	×	
W50-51003	Modified 4 mm hexagon key wrench	×	
W50-51004	Modified 22 mm open end wrench	×	
W50-51017	Trochanter	×	
W50-51022	Trochanter assembly, right	×	
W50-51023	Trochanter assembly, left	×	

Table C.1 (continued)

Drawing number	Description	Electronic file format	
		PDF	STP
W50-51034	Femoral neck assembly	×	
W50-51035	Femoral neck	×	
W50-51038	Femoral ball	×	
W50-51050	Upper leg assembly, left	×	
W50-51052	G5 DAS leg docking station	×	
W50-51053	G5 DAS structural replacement assembly	×	
W50-51058	Upper leg flesh, right, velcro application	×	×
W50-51059	Upper leg flesh, left, velcro application	×	×
W50-51060	Leg structural replacement assembly	×	
W50-51067	Leg extension tube assembly	×	
W50-51068	Leg extension tube	×	
W50-52001sheet1	Knee assembly, right	×	
W50-52001sheet2	Knee assembly, right parts list	×	
W50-52002	Knee bone assembly	×	
W50-52004	Knee cover	×	
W50-52005sheet1	Knee clevis, right	×	
W50-52005sheet2	Knee clevis, right	×	
W50-52006	Knee clevis stop	×	
W50-52007	Knee pivot shaft	×	
W50-52008	Knee pivot shaft assembly	×	
W50-52009	Knee clevis assembly, right	×	
W50-52010	Knee pad moulded assembly	×	
W50-52011	Side plate	×	
W50-52015	Knee contact load cell structural replacement assembly	×	
W50-52019sheet1	Knee assembly, left	×	
W50-52019sheet2	Knee assembly, left parts list	×	
W50-52020	Knee clevis, left	×	
W50-52021	Knee clevis assembly, left	×	
W50-52024	Knee bone	×	
W50-52063	Knee washer	×	
W50-52064	Friction washer assembly	×	
W50-52065	Braking washer	×	
W50-52066	Braking washer backing	×	
W50-53001	Lower leg tube	×	
W50-53002	Lower leg flesh	×	×
W50-53007	Zipper assembly	×	
W50-53008	Vinyl strips	×	
W50-54002	Ankle clevis right and left lower limb	×	
W50-54004	Left flexion centre rotational piece	×	
W50-54005	Ankle joint	×	

Table C.1 (continued)

Drawing number	Description	Electronic file format	
		PDF	STP
W50-54006	Base plate	×	
W50-54008	Thrust washer	×	
W50-54009	Z-pivot pin	×	
W50-54010	Z-axis rotational washer	×	
W50-54012	Potentiometer (optional)	×	
W50-54013	Potentiometer structural replacement	×	
W50-54014	Retainer bracket	×	
W50-54015	Ankle joint cover	×	
W50-54016	X-version bushing	×	
W50-54019	Front bearing cover	×	
W50-54020	Rear bearing cover	×	
W50-54021	X-version compression element	×	
W50-54022	Dorsiflexion and plantarflexion hard stop	×	
W50-54023	Z-axis nut	×	
W50-54024	Z-axis anti-rattle washer	×	
W50-54031	Z-axis rotation bearing	×	
W50-54033	Right flexion centre rotational piece	×	
W50-54034	Foot sole locator pins	×	
W50-54035	X-version resistive element	×	
W50-54036	Resistive element	×	
W50-54037	Bumper	×	
W50-54038	Orientation block	×	
W50-54041	Z-axis radial limit screw	×	
W50-54042	Front bearing assembly	×	
W50-54043	Rear bearing assembly	×	
W50-54044	X-version assembly	×	
W50-54045	Ankle joint assembly	×	
W50-54046	X-version assembly	×	
W50-54047	Clevis assembly	×	
W50-54048	Left flexion, centre assembly	×	
W50-54049	Right flexion, centre assembly	×	
W50-54050	Y-version assembly	×	
W50-54051	Z-axis potentiometer assembly (optional)	×	
W50-54052	Y-axis potentiometer assembly (optional)	×	
W50-54053	Lower leg assembly	×	
W50-54054	Ankle assembly	×	
W50-54055	Lower leg assembly, right	×	
W50-54056	Lower leg assembly, left	×	
W50-55003	Sole plate	×	
W50-55004	Left shoe	×	×

**Table C.1** (continued)

Drawing number	Description	Electronic file format	
		PDF	STP
W50-55005	Right shoe	×	×
W50-61000	Arm assembly, left	×	
W50-61001	Full arm assembly, right	×	
W50-61002	Upper arm, left assembly	×	
W50-61003	Upper arm assembly, right	×	
W50-61004	Upper arm extension tube assembly	×	
W50-61005	Upper arm z-pivot, left	×	
W50-61006	Upper arm z-pivot assembly, left	×	
W50-61007	IGUS bearing (TFI-1214-08)	×	
W50-61008	Z-stop pin	×	
W50-61010	Upper arm z-stop	×	
W50-61011	Arm tube	×	
W50-61012	Upper arm tube assembly	×	
W50-61013	Elbow shaft	×	
W50-61014	Clamping washer	×	
W50-61016	Compression washer	×	
W50-61017	Elbow stop	×	
W50-61018	Wrist pivot	×	
W50-61019	Wrist washer	×	
W50-61020	Wrist pivot assembly	×	
W50-61021	Hand bone	×	
W50-61022	Spring washer	×	
W50-61023	Elbow clevis	×	
W50-61024	Elbow clevis assembly	×	
W50-61025	Lower arm tube	×	
W50-61026	Upper arm extension bone	×	
W50-61027	Elbow potentiometer assembly	×	
W50-61028	Elbow shaft assembly	×	
W50-61029	Elbow clevis assembly	×	
W50-61030	Cable guide	×	
W50-61031	Elbow leg load cell structural replacement body	×	
W50-61032	Wrist clevis	×	
W50-61033	Wrist clevis assembly	×	
W50-61034	Lower arm assembly	×	
W50-61035	Wrist assembly	×	
W50-61036	Lower arm tube assembly	×	
W50-61037	Hand, moulded assembly, left	×	
W50-61038	Bumper	×	
W50-61039	Accelerometer, mount bracket assembly	×	
W50-61040	Accelerometer, mount bracket	×	



Table C.1 (continued)

Drawing number	Description	Electronic file format	
		PDF	STP
W50-61041	Arm leg load cell structural replacement assembly	×	
W50-61042	Modified button head screw	×	
W50-61044	Bumper	×	
W50-61045	Bumper	×	
W50-61046	Bumper, wrist pivot	×	
W50-61047	Modified IGUS bearing	×	
W50-61048	Bumper, hand	×	
W50-61049	Pivot shaft	×	
W50-61050	Pivot washer	×	
W50-61051	Shoulder clevis assembly	×	
W50-61052	Bumper, moulded assembly	×	
W50-61053	Shoulder assembly	×	
W50-61054	Flexion-extension stop assembly	×	
W50-61055	Flexion-extension stop	×	
W50-61056	Stop bumper	×	
W50-61057	Shoulder bumper plate	×	
W50-61058Sheet 1	Clevis	×	
W50-61058Sheet 2	Clevis	×	
W50-61059	Shoulder load cell abduction bumper	×	
W50-61060	Friction pad	×	
W50-61062	Elbow ballast for structural replacement	×	
W50-61063	7268-C accelerometer structural replacement	×	
W50-61065	Elbow load cell structural replacement assembly	×	
W50-61067	Moulded hand assembly, right	×	×
W50-61068	Moulded hand assembly, left	×	×
W50-61069	Hand, moulded assembly, right	×	
W50-61070-x	IGUS bearing general table	×	
W50-61074	Arm tube assembly	×	
W50-61084	Z-pivot, right	×	
W50-61090	Modified IGUS bearing	×	
W50-61098	Upper arm flesh, right, velcro application	×	×
W50-61099	Upper arm flesh, left, velcro application	×	×
W50-61100	Lower arm flesh velcro application	×	×
W50-61110	Shoulder bumper assembly	×	
W50-61111	Z-pivot assembly, right	×	
W50-61113	Shoulder clevis for half arm	×	
W50-61117	Shoulder clevis assembly	×	
W50-61123	Structural replacement-elbow potentiometer assembly	×	
W50-62000	Half arm assembly	×	×
W50-62002	Half arm bone	×	

**Table C.1** (continued)

Drawing number	Description	Electronic file format	
		PDF	STP
W50-71000	Neck load cell assembly (optional)	×	
W50-71003	Neck load cell structural replacement body	×	
W50-71005	Upper neck load cell	×	
W50-71010	Leg load cell assembly (optional)	×	
W50-71020	Knee contact load cell assembly (optional)	×	
W50-71051	Pubic symphysis load cell	×	
W50-71059	Pubic load cell structural replacement assembly	×	
W50-71060	Elbow load cell assembly (optional)	×	
W50-71070	Arm load cell assembly (optional)	×	
W50-71077	Humanetics (formally Denton) COE tilt sensor adaptor block head	×	
W50-71079	Humanetics (formally Denton) COE tilt sensor adaptor block	×	
W50-71080	Femoral neck load cell assembly (optional)	×	
W50-71081	Femoral neck load cell, left side	×	
W50-71090	Shoulder load cell assembly (optional)	×	
W50-71091	Shoulder load cell, right side	×	
W50-71092	Shoulder load cell structural replacement assembly	×	
W50-71094	Humanetics (formally Denton) COE tilt sensor adaptor block head	×	
W50-71097	Bushing	×	
W50-71098	Slug	×	
W50-71120	Lumbar spine load cell assembly (optional)	×	
W50-71122	Lumbar spine load cell structural replacement assembly	×	
W50-71123	Lumbar spine load cell structural replacement body	×	
W50-71130	Sacroiliac load cell assembly (optional)	×	
W50-71130S-D	Sacroiliac sensor assembly	×	
W50-71701	Temperature logger mass replacement	×	
W50-71965	Femoral neck load cell structural replacement assembly	×	
W50-71975	Sacro-iliac load cell structural replacement assembly	×	
W50-74307	G5 DAS structural replacement, body	×	
W50-75001	Interposer replacement	×	
W50-75002	Connector housing replacement	×	
W50-75102_sht1	Linear triax accelerometer cable, head	×	
W50-75102_sht2	Linear triax accelerometer cable, head	×	
W50-75108_sht1	Rotational accelerometer cable, universal	×	
W50-75108_sht2	Rotational accelerometer cable, universal	×	
W50-75201_sht1	Linear triax accelerometer cable, universal	×	
W50-75201_sht2	Linear triax accelerometer cable, universal	×	
W50-75801	Head to thorax	×	
W50-75802	Torso to sacrum	×	
W50-75803	Sacrum to pubic	×	
W50-75804	Sacrum to upper leg	×	

Table C.1 (continued)

Drawing number	Description	Electronic file format	
		PDF	STP
W50-75805	Upper leg to lower leg	×	
W50-75806	Torso to external ground	×	
W50-80100	WorldSID suit	×	
W50-82100	Head drop bracket assembly, WorldSID	×	
W50-82101	Base plate	×	
W50-82102	Joint bracket	×	
W50-82103	Head drop bracket	×	
W50-82104	Joint bracket, top	×	
W50-82105	Plate, magnet	×	
W50-82200	WorldSID bench	×	
W50-82245	Polytetrafluoroethylene (PTFE)® sheet	×	
W50-82246	Polytetrafluoroethylene (PTFE)® sheet	×	
W50-82500	H-point tool	×	
W50-82501	H-point tool plate	×	
W50-82502	H-point tool rod	×	
W50-82600	C wrench	×	
W50-82601	C wrench head	×	
W50-82602	C wrench handle	×	
W50-83000	Headform assembly, WorldSID	×	
W50-83101	Centre plate	×	
W50-83102	Disc A, WorldSID headform	×	
W50-83103	Disc B, WorldSID headform	×	
W50-83104	Upper neck interface plate	×	
W50-83201	Lower neck interface plate	×	
W50-83202	Shaft	×	
W50-83205	Shaft coupling	×	
W50-83206	Mounting base	×	
W50-83207	Potentiometer mounting bracket	×	
W50-84100	Lifting bracket assembly, WorldSID	×	
W50-84104	Handle, threaded hole	×	
W50-84106	Handle, threaded rod	×	
W50-84110	Lifting bracket weldment	×	
W50-84111	Upper rod	×	
W50-84112	Lower rod	×	
W50-84113	Middle bar	×	
W50-84114	Wedge	×	
W5-3325	Battery replacement		
W5-3326	Thermal pad		
000-2001	T-insert	×	
734-0800	Temperature logger assembly	×	

**Table C.1** (continued)

Drawing number	Description	Electronic file format	
		PDF	STP
E_BF	Neck compression tool	×	
E2-20123	Neck intermediate plate	×	
F_D	Potentiometer assembly	×	
F_DA	Potentiometer housing assembly	×	
F_DB	Potentiometer clamp	×	
F_DE	Bearing	×	
F_DF	Potentiometer housing	×	
f_e	Coupling assembly	×	
f_ea	Coupling	×	
f_eb	Bearing	×	
F_GA	Arrow shaft-pivot assembly A	×	
F_GB	Arrow shaft-pivot assembly B	×	
F_GC	Arrow shaft assembly	×	
F_GD	Pivot, inside assembly	×	
F_GE	Pin, machined	×	
F_GH	Pivot, outside	×	
F_GJ	Pivot, inside	×	
F_GK	Coupling	×	
F_GL	Arrow shaft	×	
F_HC	Space	×	
F_IA	Rotary potentiometer	×	
IF-363	IR-TRACC specification sheet	×	

**Table C.2 — WorldSID fasteners**

Description	Fastener number
Ball nose spring plunger MCM# 84895A21	5000257
Ball nose spring plunger MCM# 84895A73	5000256
BHCS M10 × 1,5 × 20 mm	5000176
BHCS M2,5 × 10	5000208
BHCS M2,5 × 3	5000248
BHCS M2,5 × 6	5000244
BHCS M3 × 0,5 × 10 mm	5000178
BHCS M3 × 0,5 × 6 mm	5000171
BHCS M4 × 0,7 × 10 mm	5000010
BHCS M4 × 0,7 × 12 mm	5000005
BHCS M4 × 0,7 × 6 mm	5000179
BHCS M4 × 16	5000153
BHCS M5 × 0,8 × 25	5000466
BHCS M5 × 0,8 × 10,0	5000003
BHCS M5 × 20	5000210

Table C.2 (continued)

Description	Fastener number
BHCS M5 × 6	5000214
BHCS M6 × 1 × 18	5000465
BHCS M6 × 1,0 × 16	5000072
BHCS M6 × 22	5000211
BHCS M2,5 × 0,45 × 5	5000429
BHCS M6 × 1 × 20	5000438
BHCS M8 × 1,25 × 25	5000255
Cable clamp	5000191
Cheese screw M2 × 10	5000220
Cheese screw M2 × 12	5000253
Cheese screw M2 × 16	5000254
Cheese screw M2 × 18	5000221
Cheese screw M3 × 6	5000222
Dowel pin M1,5 × 5 mm	5000224
Dowel pin M1,5 × 6 mm	5000167
Dowel pin M2 × 5 mm	5000225
Dowel pin M3 × 12 mm	5000183
Dowel pin M3 × 16 mm	5000223
Dowel pin M3 × 6 mm	5000385
Dowel pin M3 × 8 mm	5000384
Dowel pin M4 × 10	5000414
Dowel pin M4 × 14	5000053
Dowel pin M5 × 16	5000331
Dowel pin M6 × 12 mm	5000217
FHCS M2 × 12	5000207
FHCS M2,5 × 12	5000206
FHCS M2,5 × 6	5000202
FHCS M3 × 10	5000203
FHCS M4 × 0,7 × 12 mm	5000177
FHCS M5 × 0,8 × 16	5000467
FHCS M5 × 0,8 × 10	5000084
FHCS M6 × 1,0 × 20,0	5000036
FHCS M6 × 10	5000204
FHCS M6 × 16 stainless steel	5000090
FHCS M6 × 30	5000265
Flat washer M3	5000181
Flat washer M4	5000155
Helicoil M4 × 0,7 × 8 mm	5000047
Helicoil M4 × 12 mm	5000205
Helicoil M4 × 6 mm	5000200
Helicoil M5 × 10 mm	5000213

**Table C.2** (continued)

<b>Description</b>	<b>Fastener number</b>
Helicoil M6 × 1 × 6	5000049
Helicoil M6 × 1,0 × 6 mm	5000087
Helicoil M6 × 1,0 × 9	5000088
Helicoil M6 × 12 mm	5000175
Helicoil M8 × 1,25 × 8	5000348
Hex nut M2	5000216
Hex nut with nylon locking insert M14	5000219
HH BOLT M8 × 1,25 × 10	5000569
Locknut M6 HEX	5000143
Locknut, nylon insert, M12 × 1,75	5000462
LWSHCS M3 × 0,5 × 12 mm	5000620
LWSHCS M6 × 1,0 × 12 mm	5000194
Retaining ring 12 mm Steel	5000249
Retaining ring 16 mm Steel	5000250
Retaining ring 18 mm Steel	5000251
Roll pin M1,5 × 8 mm	5000189
Roll pin M3 × 10 mm	5000199
Roll pin M3 × 12 mm	5000166
Roll pin M3 × 14 mm	5000196
Roll pin M3 × 20 mm	5000188
Roll pin M3 × 8 mm	5000195
Roll pin M4 × 10 mm	5000182
Roll pin M4 × 14 mm	5000197
SHCS M1,6 × 0,35 × 5	5000338
SHCS M1,6 × 6 CLASS 12,9 Alloy steel	5000343
SHCS M2 × 0,4 × 18 mm	5000164
SHCS M2 × 0,4 × 6 mm	5000082
SHCS M2 × 0,4 × 8 mm	5000083
SHCS M2 × 10	5000215
SHCS M3 × 0,5 × 6	5000393
SHCS M3 × 0,5 × 12 mm	5000070
SHCS M3 × 10	5000119
SHCS M3 × 14	5000252
SHCS M4 × 0,7 × 10	5000151
SHCS M4 × 0,7 × 8,0	5000024
SHCS M5 × 0,8 × 12 mm	5000002
SHCS M5 × 0,8 × 16 mm	5000020
SHCS M5 × 18	5000112
SHCS M6 × 1,0 × 16	5000081
SHCS M6 × 1,0 × 20,0	5000001
SHCS M6 × 12	5000281

**Table C.2** (continued)

<b>Description</b>	<b>Fastener number</b>
SHCS M6 × 50	5000324
SHCS M8 × 18	5000209
SHCS, M3 × 0,5 × 8	5000388
SHCS, M4 × 0,7 × 14	5000459
SHCS, M4 × 0,7 × 25	5000461
SHCS, M5 × 0,8 × 30	5000471
SHCS, M6 × 1 × 10	5000457
SHSS M6 × 25 mm	5000163
Spring washer M6	5000134
SSCP M2.5 × 5	5000340
SSCP M3 × 0,5 × 4 mm	5000470
SSCP M3 × 16	5000212
SSCP M4 × 0,7 × 6 mm	5000076
SSCP M6 × 1,0 × 8 mm	5000622
SSCP nylon tip M4 × 0,7 × 10	5000260
SSFP flat point M4 × 6	5000464
SSFT M6 × 10 mm	5000226
SSHDP M6 × 1,0 × 6 mm	5000165
SSHDP M6 × 1,0 × 12 mm	5000185
SSNT M3 × 0,5 × 3 mm	5000190
SSNT M4 × 0,7 × 4 mm	5000201
SSNT M6 × 1,0 × 6 mm	5000621
Threaded rod M12 × 1,5	5000048
Washer, flat M1,6 × 1,7 × 4 × 0,25	5000428
Washer, flat M8 (8,9 ID × 18,8 OD × 2,3 THK)	5000123







# British Standards Institution (BSI)

BSI is the national body responsible for preparing British Standards and other standards-related publications, information and services.

BSI is incorporated by Royal Charter. British Standards and other standardization products are published by BSI Standards Limited.

## About us

We bring together business, industry, government, consumers, innovators and others to shape their combined experience and expertise into standards-based solutions.

The knowledge embodied in our standards has been carefully assembled in a dependable format and refined through our open consultation process. Organizations of all sizes and across all sectors choose standards to help them achieve their goals.

## Information on standards

We can provide you with the knowledge that your organization needs to succeed. Find out more about British Standards by visiting our website at [bsigroup.com/standards](http://bsigroup.com/standards) or contacting our Customer Services team or Knowledge Centre.

## Buying standards

You can buy and download PDF versions of BSI publications, including British and adopted European and international standards, through our website at [bsigroup.com/shop](http://bsigroup.com/shop), where hard copies can also be purchased.

If you need international and foreign standards from other Standards Development Organizations, hard copies can be ordered from our Customer Services team.

## Subscriptions

Our range of subscription services are designed to make using standards easier for you. For further information on our subscription products go to [bsigroup.com/subscriptions](http://bsigroup.com/subscriptions).

With **British Standards Online (BSOL)** you'll have instant access to over 55,000 British and adopted European and international standards from your desktop. It's available 24/7 and is refreshed daily so you'll always be up to date.

You can keep in touch with standards developments and receive substantial discounts on the purchase price of standards, both in single copy and subscription format, by becoming a **BSI Subscribing Member**.

**PLUS** is an updating service exclusive to BSI Subscribing Members. You will automatically receive the latest hard copy of your standards when they're revised or replaced.

To find out more about becoming a BSI Subscribing Member and the benefits of membership, please visit [bsigroup.com/shop](http://bsigroup.com/shop).

With a **Multi-User Network Licence (MUNL)** you are able to host standards publications on your intranet. Licences can cover as few or as many users as you wish. With updates supplied as soon as they're available, you can be sure your documentation is current. For further information, email [bsmusales@bsigroup.com](mailto:bsmusales@bsigroup.com).

## BSI Group Headquarters

389 Chiswick High Road London W4 4AL UK

## Revisions

Our British Standards and other publications are updated by amendment or revision.

We continually improve the quality of our products and services to benefit your business. If you find an inaccuracy or ambiguity within a British Standard or other BSI publication please inform the Knowledge Centre.

## Copyright

All the data, software and documentation set out in all British Standards and other BSI publications are the property of and copyrighted by BSI, or some person or entity that owns copyright in the information used (such as the international standardization bodies) and has formally licensed such information to BSI for commercial publication and use. Except as permitted under the Copyright, Designs and Patents Act 1988 no extract may be reproduced, stored in a retrieval system or transmitted in any form or by any means – electronic, photocopying, recording or otherwise – without prior written permission from BSI. Details and advice can be obtained from the Copyright & Licensing Department.

## Useful Contacts:

### Customer Services

**Tel:** +44 845 086 9001

**Email (orders):** [orders@bsigroup.com](mailto:orders@bsigroup.com)

**Email (enquiries):** [cservices@bsigroup.com](mailto:cservices@bsigroup.com)

### Subscriptions

**Tel:** +44 845 086 9001

**Email:** [subscriptions@bsigroup.com](mailto:subscriptions@bsigroup.com)

### Knowledge Centre

**Tel:** +44 20 8996 7004

**Email:** [knowledgecentre@bsigroup.com](mailto:knowledgecentre@bsigroup.com)

### Copyright & Licensing

**Tel:** +44 20 8996 7070

**Email:** [copyright@bsigroup.com](mailto:copyright@bsigroup.com)



...making excellence a habit.™