

BS ISO 15765-4:2016



BSI Standards Publication

Road vehicles — Diagnostic communication over Controller Area Network (DoCAN)

Part 4: Requirements for emissions-related systems

bsi.

National foreword

This British Standard is the UK implementation of ISO 15765-4:2016. It supersedes BS ISO 15765-4:2011+A1:2013 which is withdrawn.

The UK participation in its preparation was entrusted to Technical Committee AUE/16, Data Communication (Road Vehicles).

A list of organizations represented on this committee can be obtained on request to its secretary.

This publication does not purport to include all the necessary provisions of a contract. Users are responsible for its correct application.

© The British Standards Institution 2016. Published by BSI Standards Limited 2016

ISBN 978 0 580 89344 5

ICS 43.040.15

Compliance with a British Standard cannot confer immunity from legal obligations.

This British Standard was published under the authority of the Standards Policy and Strategy Committee on 30 April 2016.

Amendments issued since publication

Date	Text affected
------	---------------

**Road vehicles — Diagnostic
communication over Controller Area
Network (DoCAN) —**

**Part 4:
Requirements for emissions-related
systems**

*Véhicules routiers — Diagnostic sur gestionnaire de réseau de
communication (DoCAN) —*

Partie 4: Exigences applicables aux systèmes associés aux émissions





COPYRIGHT PROTECTED DOCUMENT

© ISO 2016, Published in Switzerland

All rights reserved. Unless otherwise specified, no part of this publication may be reproduced or utilized otherwise in any form or by any means, electronic or mechanical, including photocopying, or posting on the internet or an intranet, without prior written permission. Permission can be requested from either ISO at the address below or ISO's member body in the country of the requester.

ISO copyright office
Ch. de Blandonnet 8 • CP 401
CH-1214 Vernier, Geneva, Switzerland
Tel. +41 22 749 01 11
Fax +41 22 749 09 47
copyright@iso.org
www.iso.org

Contents

Page

Foreword	v
Introduction	vi
1 Scope	1
2 Normative references	1
3 Terms, definitions, symbols and abbreviated terms	2
3.1 Terms and definitions.....	2
3.2 Symbols.....	2
3.3 Abbreviated terms.....	2
4 Conventions	3
5 Document overview	3
6 External test equipment initialization sequence	4
6.1 General.....	4
6.2 Baudrate validation procedure.....	7
6.2.1 BaudrateRecord.....	7
6.2.2 Baudrate validation.....	7
6.2.3 External test equipment error detection provisions.....	9
6.3 CAN identifier validation procedure.....	9
6.3.1 CAN identifier validation procedure OBD.....	9
6.3.2 CAN identifier validation procedure WWH-OBD.....	11
7 Application layer	13
8 Session layer	14
9 Transport protocol layer	14
10 Network layer	14
10.1 General.....	14
10.2 Network layer parameters.....	14
10.2.1 Timing parameter values.....	14
10.2.2 Definition of Flow Control parameter values.....	15
10.2.3 Maximum number of legislated OBD/WWH-OBD ECUs.....	16
10.3 Addressing formats.....	17
10.3.1 Normal and fixed addressing format.....	17
10.3.2 Functional addressing.....	17
10.3.3 Physical addressing.....	17
10.4 CAN identifier requirements.....	18
10.4.1 External test equipment.....	18
10.4.2 Legislated OBD/WWH-OBD server/ECU.....	18
10.5 Mapping of diagnostic addresses.....	19
10.5.1 Legislated OBD/WWH-OBD CAN identifiers.....	19
10.5.2 11 bit CAN identifiers.....	19
10.5.3 29 bit CAN identifiers.....	20
10.6 Support of ECUNAME reporting.....	21
11 Data link layer	21
12 Physical layer	21
12.1 General.....	21
12.2 External test equipment baudrates.....	21
12.3 External test equipment CAN bit timing.....	21
12.3.1 CAN bit timing parameter values.....	21
12.3.2 Nominal baudrate 250 kBit/s.....	22
12.3.3 Nominal baudrate 500 kBit/s.....	23
12.4 External test equipment.....	23

12.4.1	General.....	23
12.4.2	CAN interface.....	24
12.4.3	External test equipment cable.....	26
Bibliography	27

Foreword

ISO (the International Organization for Standardization) is a worldwide federation of national standards bodies (ISO member bodies). The work of preparing International Standards is normally carried out through ISO technical committees. Each member body interested in a subject for which a technical committee has been established has the right to be represented on that committee. International organizations, governmental and non-governmental, in liaison with ISO, also take part in the work. ISO collaborates closely with the International Electrotechnical Commission (IEC) on all matters of electrotechnical standardization.

The procedures used to develop this document and those intended for its further maintenance are described in the ISO/IEC Directives, Part 1. In particular the different approval criteria needed for the different types of ISO documents should be noted. This document was drafted in accordance with the editorial rules of the ISO/IEC Directives, Part 2 (see www.iso.org/directives).

Attention is drawn to the possibility that some of the elements of this document may be the subject of patent rights. ISO shall not be held responsible for identifying any or all such patent rights. Details of any patent rights identified during the development of the document will be in the Introduction and/or on the ISO list of patent declarations received (see www.iso.org/patents).

Any trade name used in this document is information given for the convenience of users and does not constitute an endorsement.

For an explanation on the meaning of ISO specific terms and expressions related to conformity assessment, as well as information about ISO's adherence to the WTO principles in the Technical Barriers to Trade (TBT) see the following URL: [Foreword - Supplementary information](#)

The committee responsible for this document is ISO/TC 22, *Road vehicles*, Subcommittee SC 31, *Data communication*.

This third edition cancels and replaces the second edition (ISO 15765-4:2011), which has been technically revised. It also incorporates the Amendment ISO 15765-4:2011/Amd 1:2013.

ISO 15765 consists of the following parts, under the general title *Road vehicles — Diagnostic communication over Controller Area Network (DoCAN)*¹⁾:

- *Part 1: General information and use case definition*
- *Part 2: Transport protocol and network layer services*
- *Part 4: Requirements for emissions-related systems*

1) ISO 15765-3 Implementation of unified diagnostic services (UDS on CAN) has been withdrawn and replaced by ISO 14229-3 Road vehicles — Unified diagnostic services (UDS) — Part 3: Unified diagnostic services on CAN implementation (UDSonCAN)

Introduction

This part of ISO 15765 has been established in order to define common requirements for vehicle diagnostic systems implemented on a Controller Area Network (CAN) communication link, as specified in ISO 11898. Although primarily intended for diagnostic systems, it also meets requirements from other CAN-based systems needing a network layer protocol.

To achieve this, it is based on the Open Systems Interconnection (OSI) Basic Reference Model, in accordance with ISO/IEC 7498-1 and ISO/IEC 10731, which structures communication systems into seven layers as shown in [Table 1](#).

Table 1 — Enhanced and legislated OBD diagnostic specifications applicable to the OSI layers

OSI 7 layers ^a	Vehicle-manufacturer-enhanced diagnostics	Legislated OBD (on-board diagnostics)	Legislated WWH-OBD (on-board diagnostics)
Application (layer 7)	ISO 14229-1, ISO 14229-3	ISO 15031-5	ISO 27145-3, ISO 14229-1
Presentation (layer 6)	Vehicle manufacturer specific	ISO 15031-2, ISO 15031-5, ISO 15031-6, SAE J1930-DA, SAE J1979-DA, SAE J2012-DA	ISO 27145-2, SAE 1930-DA, SAE J1979-DA, SAE J2012-DA, SAE J1939-DA (SPNs), SAE J1939-73 Appendix A (FMIs)
Session (layer 5)	ISO 14229-2		
Transport protocol (layer 4)	ISO 15765-2	ISO 15765-2	ISO 15765-4, ISO 15765-2
Network (layer 3)			
Data link (layer 2)	ISO 11898-1	ISO 11898-1	ISO 15765-4, ISO 11898-1
Physical (layer 1)	ISO 11898-1, ISO 11898-2, ISO 11898-3, or vehicle manufacturer specific	ISO 11898-1, ISO 11898-2	ISO 15765-4, ISO 11898-1, ISO 11898-2
			ISO 27145-4

^a 7 layers according to ISO/IEC 7498-1 and ISO/IEC 10731

The application layer services covered by ISO 14229-3 have been defined in compliance with diagnostic services established in ISO 14229-1 and ISO 15031-5, but are not limited to use only with them.

The transport protocol and network layer services covered by this part of ISO 15765 have been defined to be independent of the physical layer implemented, and a physical layer is only specified for legislated on-board diagnostics (OBD).

For other application areas, ISO 15765 can be used with any CAN physical layer.

Road vehicles — Diagnostic communication over Controller Area Network (DoCAN) —

Part 4: Requirements for emissions-related systems

1 Scope

This part of ISO 15765 specifies requirements for Controller Area Networks (CAN) where one or more controllers comply with on-board diagnostics (OBD) or world-wide harmonized on-board diagnostics (WWH-OBD) regulations. The network presumes the use of an external test equipment for inspection and repair diagnostics, as defined by the regulations. The CAN network requirements for the vehicle and the external test equipment are based on the specifications of ISO 15765-2, ISO 11898-1 and ISO 11898-2.

This part of ISO 15765 places restrictions on those International Standards for the fulfilment of the regulations. It does not specify in-vehicle CAN bus architecture, but seeks to ensure that the vehicle's regulated CAN communications comply with external test equipment requirements.

This part of ISO 15765 defines the requirements to successfully establish, maintain and terminate communication with a vehicle that implements the requirements of the OBD/WWH-OBD regulations. Plug-and-play communication capabilities among vehicles and test equipment are defined to assure the interoperation of external test equipment and vehicles. This part of ISO 15765 details all of the OSI layer requirements to achieve this goal.

This part of ISO 15765 is the entry point for DoCAN (Diagnostic communication over Controller Area Network). Based on the results of the initialization, the external test equipment determines which protocol and diagnostic services are supported by the vehicle's emissions-related system:

- legislated OBD: ISO 15031 (all parts);
- legislated WWH-OBD: ISO 27145 (all parts).

2 Normative references

The following documents, in whole or in part, are normatively referenced in this document and are indispensable for its application. For dated references, only the edition cited applies. For undated references, the latest edition of the referenced document (including any amendments) applies.

ISO 11898-1, *Road vehicles — Controller area network (CAN) — Part 1: Data link layer and physical signalling*

ISO 11898-2, *Road vehicles — Controller area network (CAN) — Part 2: High-speed medium access unit*

ISO 15031-5, *Road vehicles — Communication between vehicle and external equipment for emissions-related diagnostics — Part 5: Emissions-related diagnostic services*

ISO 15765-2, *Road vehicles — Diagnostic communication over Controller Area Networks (DoCAN) — Part 2: Transport protocol and network layer services*

ISO 27145-3, *Road vehicles — Implementation of World-Wide Harmonized On-Board Diagnostics (WWH-OBD) communication requirements — Part 3: Common message dictionary*

ISO 27145-4, *Road vehicles — Implementation of World-Wide Harmonized On-Board Diagnostics (WWH-OBD) communication requirements — Part 4: Connection between vehicle and test equipment*

3 Terms, definitions, symbols and abbreviated terms

3.1 Terms and definitions

For the purposes of this document, the terms and definitions given in ISO 15765-2 apply.

3.2 Symbols

Symbol	Definition	Unit
C_{AC1}, C_{AC2}	capacitance of a.c. termination	F
C_{CAN_H}	capacitance between CAN_H and ground potential	F
C_{CAN_L}	capacitance between CAN_L and ground potential	F
C_{DIFF}	capacitance between CAN_H and CAN_L	F
Δf	oscillator tolerance	Hz
l_{CABLE}	maximum cable length between OBD/WWH-OBD connector and external test equipment	m
Prop_Seg	propagation segment	
Phase_Seg1	phase segment 1	
Phase_Seg2	phase segment 2	
R_{AC1}, R_{AC2}	resistance of a.c. termination	Ω
Sync_Seg	synchronization segment	
t_{BIT}	bit time	μs
t_{BIT_RX}	receive bit time	μs
t_{BIT_TX}	transmit bit time	μs
t_{CABLE}	external-test-equipment cable propagation delay (without external test equipment CAN interface delay)	μs
t_{SEG1}	timing segment 1	μs
t_{SEG2}	timing segment 2	μs
t_{SJW}	resynchronization jump width	μs
$t_{SYNCSEG}$	synchronization segment	μs
t_{TOOL}	external test equipment CAN interface propagation delay (without external test equipment cable delay)	μs
t_Q	time quantum	μs

3.3 Abbreviated terms

BS	block size
CAN	controller area networks
CF	consecutive frame
DLC	data length code
DoCAN	diagnostic communication over CAN
ECU	electronic control unit
ECM	engine control module
FC	flow control
FF	first frame
FS	flow status

OBD	on-board diagnostics
SA	source address
SF	single frame
SJW	synchronization jump width
SP	nominal sample point
TA	target address
TCM	transmission control module
WWH-OBD	world-wide harmonized on-board diagnostics

4 Conventions

ISO 15765 is based on the conventions specified in the OSI Service Conventions (ISO/IEC 10731:1994) as they apply for diagnostic services.

5 Document overview

[Figure 1](#) illustrates the most applicable application implementations utilizing the DoCAN protocol.

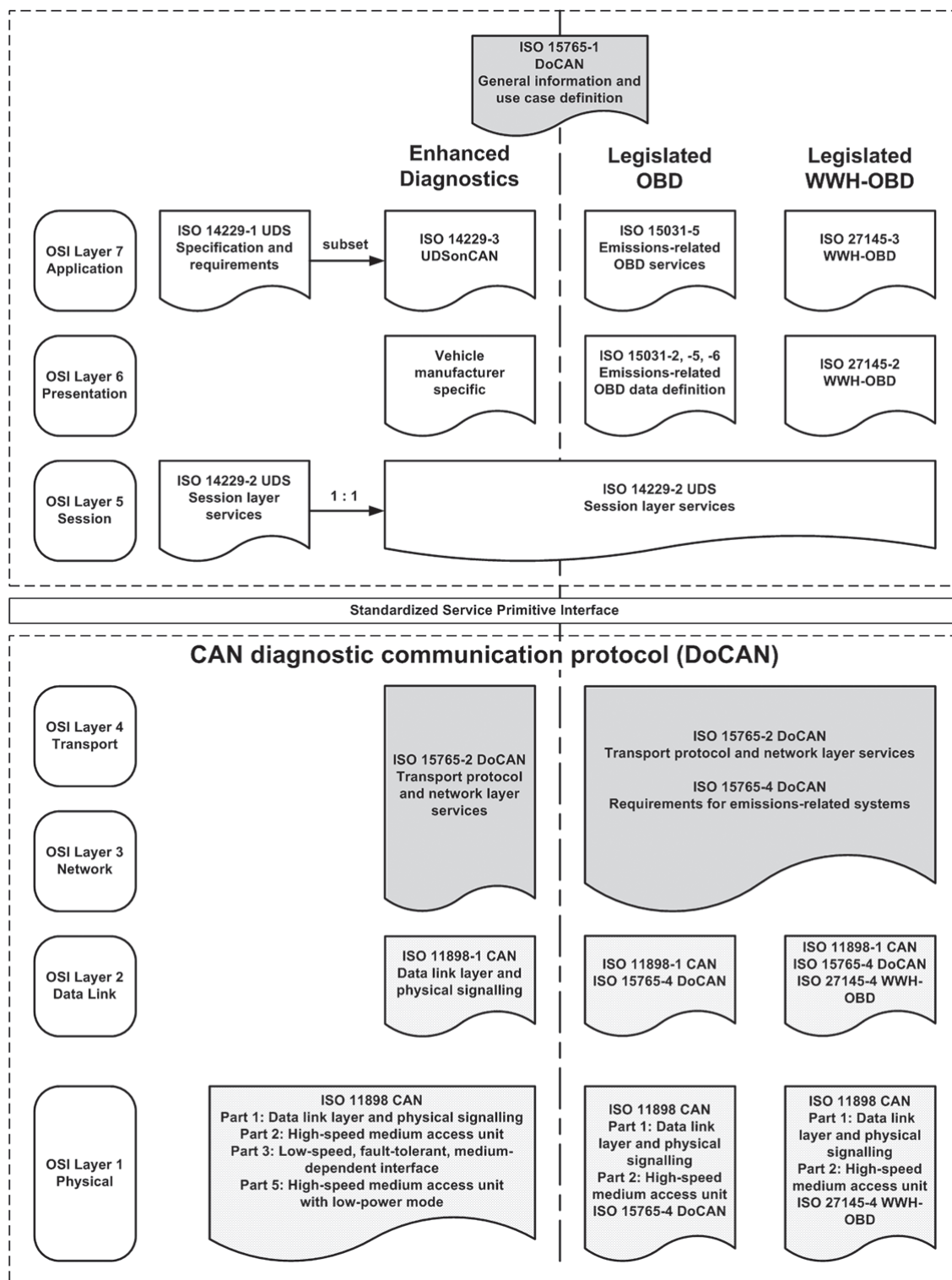

Figure 1 — Diagnostic communication over CAN document reference according to OSI model

6 External test equipment initialization sequence

6.1 General

The external test equipment shall support the initialization sequence specified in this part of ISO 15765 (see [Figure 2](#)).

The purpose of the external test equipment initialization sequence is to automatically detect whether the vehicle supports legislated OBD or WWH-OBD on CAN using the physical layer specified in [Clause 12](#).

Furthermore, the initialization sequence determines the communication compliance status of vehicles by analysing their responses to

- ISO 15031-5 service 01₁₆ 00₁₆ (PID supported) requests, or
- ISO 27145-3 service 22₁₆ F8₁₆ 10₁₆ (DID protocol identification) request with a positive response.

Only vehicles that follow the WWH-OBD regimen will have ECUs that reply to the functional request service 22₁₆ DID F810₁₆ for protocol identification. Vehicles that respond only to the functional request service 01₁₆ PID 00₁₆ support earlier OBD communication methods. Vehicles that do not respond to either request do not support regulated OBD diagnostics under this part of ISO 15765. [6.3](#) describes this procedure.

For each legislated OBD/WWH-OBD service that requires the determination of “supported” information, the external test equipment has to update its list of expected responding legislated OBD/WWH-OBD ECUs prior to any data parameter requests. For applicable services, see either ISO 15031-5 (for legislated OBD) or ISO 27145-3 (for legislated WWH-OBD).

The external test equipment initialization sequence supports single baudrate initialization (e.g. 500 kBit/s) and multiple baudrate initialization (e.g. 250 kBit/s and 500 kBit/s) and is separated into the following tests:

- a) 11 bit CAN identifier validation;
- b) 29 bit CAN identifier validation.

NOTE See [6.2.2](#).

The external test equipment initialization sequence contains provisions for legacy vehicles using either CAN (same or different physical layer as defined for legislated OBD/WWH-OBD) or a different protocol (non-CAN) on the CAN pins of the ISO 15031-3 diagnostic connector.

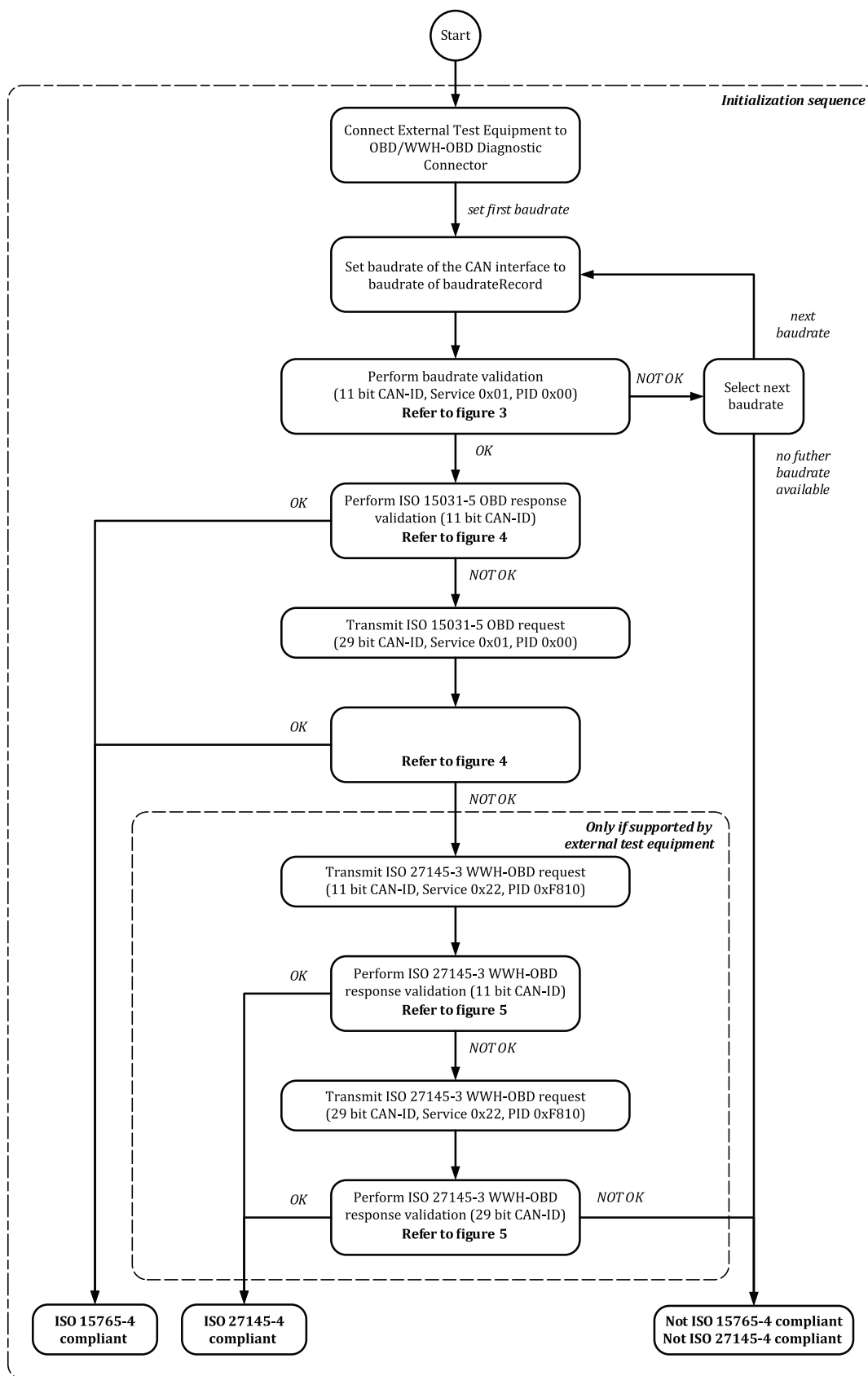

Figure 2 — Initialization sequence overview

6.2 and 6.3 describe the external test equipment initialization to determine baudrate and CAN identifier (11 bit or 29 bit) for OBD (ISO 15031) and WWH-OBD (ISO 27145).

6.2 Baudrate validation procedure

6.2.1 BaudrateRecord

By default, the parameter “baudrateRecord” contains all baudrates specified in [12.3](#). The content of the baudrateRecord can be superseded by any other list of baudrates, e.g. single 500 kBit/s baudrate as specified in [12.3.3](#).

The baudrateRecord shall be used to specify the type of initialization to be performed. If the baudrateRecord parameter contains a single baudrate, then a single-baudrate initialization sequence shall be performed using the specified single baudrate (e.g. 500 kBit/s). If the baudrateRecord parameter contains multiple baudrates, then a multiple-baudrate initialization sequence shall be performed including a baudrate detection procedure as defined in [Figure 4](#).

[Figure 3](#) shall be performed using the specified multiple baudrates (e.g. 250 kBit/s and 500 kBit/s). For legislated OBD/WWH-OBD baudrates, the external test equipment shall use the appropriate CAN bit timing parameter values defined in [12.3](#).

6.2.2 Baudrate validation

If multiple baudrates are specified in the baudrateRecord parameter, the procedure as defined in [Figure 3](#) shall be used to determine the baudrate to be used in communication with the vehicle.

The external test equipment shall set up its CAN interface using the first baudrate contained in the baudrateRecord. It shall use the CAN bit timing parameter values defined for this baudrate (see [12.3](#)).

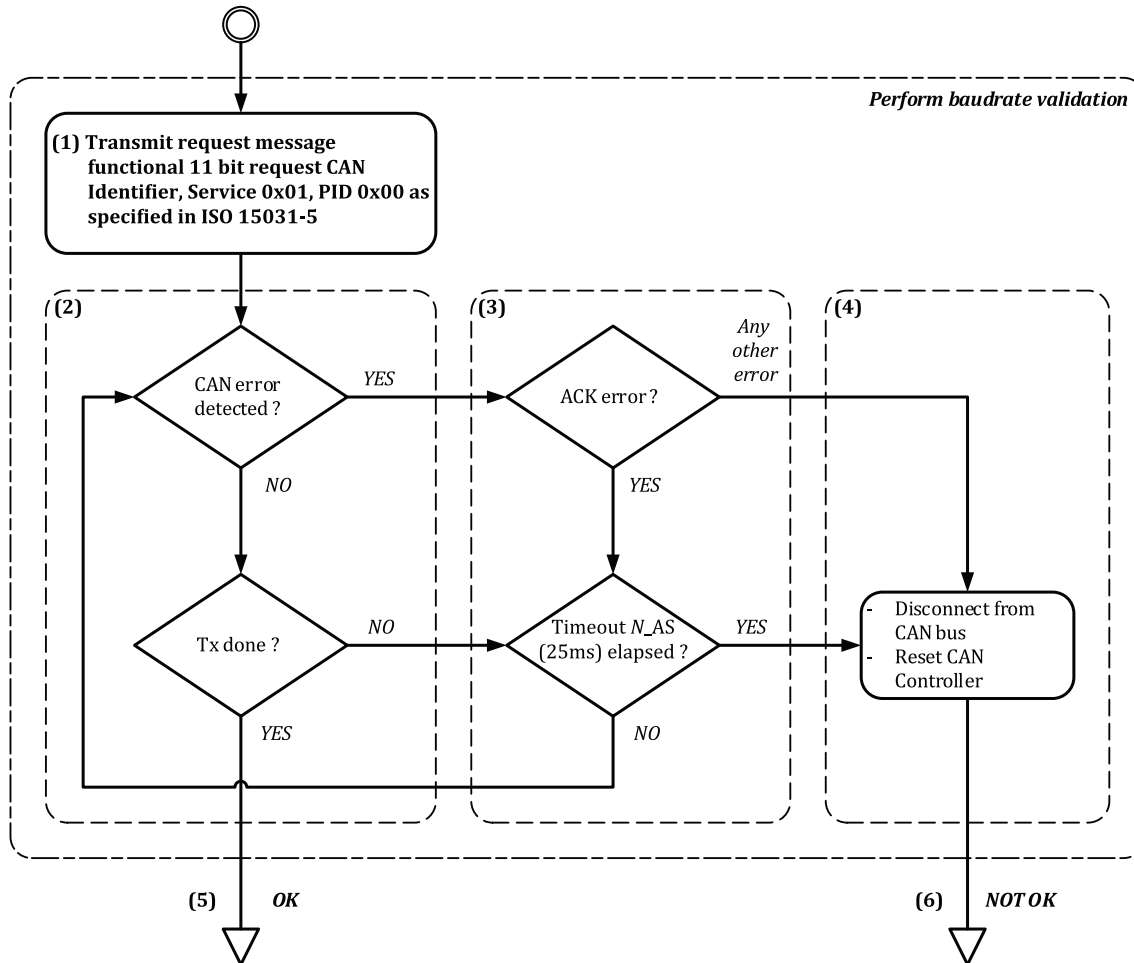

Key

- 1 Following the CAN interface setup, the external test equipment shall connect to the CAN bus and immediately transmit a functionally addressed request message with service 0116 (read supported PIDs) using the legislated OBD/WWH-OBD 11 bit functional request CAN identifier as defined in [10.5.2](#).
 NOTE The immediate transmission is needed in order to activate the CAN error monitoring as specified further down, since initializing the CAN controller at the wrong baudrate without transmitting any data can leave the CAN controller in a state of generating error frames on the CAN bus.
- 2 The external test equipment shall check for any CAN error. If the request message is successfully transmitted onto the CAN bus, the external test equipment shall indicate a successful transmission and proceed with the validation of the CAN identifier as specified in [6.3](#).
- 3 If an acknowledge (ACK) check error is detected, then the external test equipment shall continue to retry the transmission of the request message until the 25 ms timeout (N_{As}) has elapsed.
- 4 If any other CAN error occurred, or an acknowledge check error still occurs after the 25 ms (N_{As}) timeout has elapsed, then the external test equipment shall disconnect its CAN interface from the CAN bus.
- 5 Proceed with sequence according to [Figure 4](#).
- 6 The external test equipment shall check whether more baudrates are contained in the baudrateRecord. If the end of the baudrateRecord is not reached, the external test equipment shall set up its CAN interface using the next baudrate in the baudrateRecord and restart the baudrate validation at step (1) in [Figure 3](#). If no further baudrate is contained in the baudrateRecord, it shall be assumed that the request was not transmitted successfully. This indicates that the vehicle complies with neither this part of ISO 15765 nor ISO 27145-4.

Figure 3 — Perform baudrate validation

6.2.3 External test equipment error detection provisions

Where the vehicle uses a CAN with a physical layer different from that specified for OBD/WWH-OBD (see [Clause 12](#)) or a non-CAN protocol on the CAN pins of the OBD/WWH-OBD connector, the transmit procedure specified in this part of ISO 15765 shall guarantee that in all cases, the external test equipment will detect that the vehicle does not support CAN as specified for legislated OBD/WWH-OBD and will stop the transmission of the request message immediately.

Where the vehicle uses CAN and the physical layer in accordance with [Clause 12](#), the transmit procedure given as follows shall guarantee that in all cases, the external test equipment will detect that it uses the wrong baudrate for the transmission of the request message and will stop disturbing the CAN bus immediately. Under normal in-vehicle conditions (i.e. no error frames during in-vehicle communication when the external test equipment is disconnected), the external test equipment will disable its CAN interface prior to the situation where the internal error counters of the legislated OBD/WWH-OBD ECU(s) reach critical values.

To achieve this, the external test equipment shall implement the following provisions:

- possibility to immediately stop sending during transmission of any CAN frame;
 - the CAN interface should be disconnected within 12 μ s from reception of a bus frame error signal. The maximum time for the disconnection is 100 μ s;
 - with the CAN interface disconnected, the external test equipment shall not be able to transmit dominant bits on the CAN bus;
- possibility to immediately detect any frame error on the CAN bus.

The second provision implies that the external test equipment cannot solely rely on the usual CAN controller error handling since it will most likely flag a frame error only after the “bus-off” state has been reached (refer to ISO 11898-1 for further details).

6.3 CAN identifier validation procedure

6.3.1 CAN identifier validation procedure OBD

The response handling procedure shall be used to receive 11 bit CAN identifier response messages from legislated OBD ECU(s) or to indicate that no response message has been received. If legislated OBD-related ECUs are detected, this procedure also builds the list of available ECUs on the legislated OBD-compliant vehicle.

The response validation procedure shall be performed as defined in [Figure 4](#), after the 11 bit CAN identifier request message transmit procedure (see [Figure 3](#)) has succeeded (“OK”).

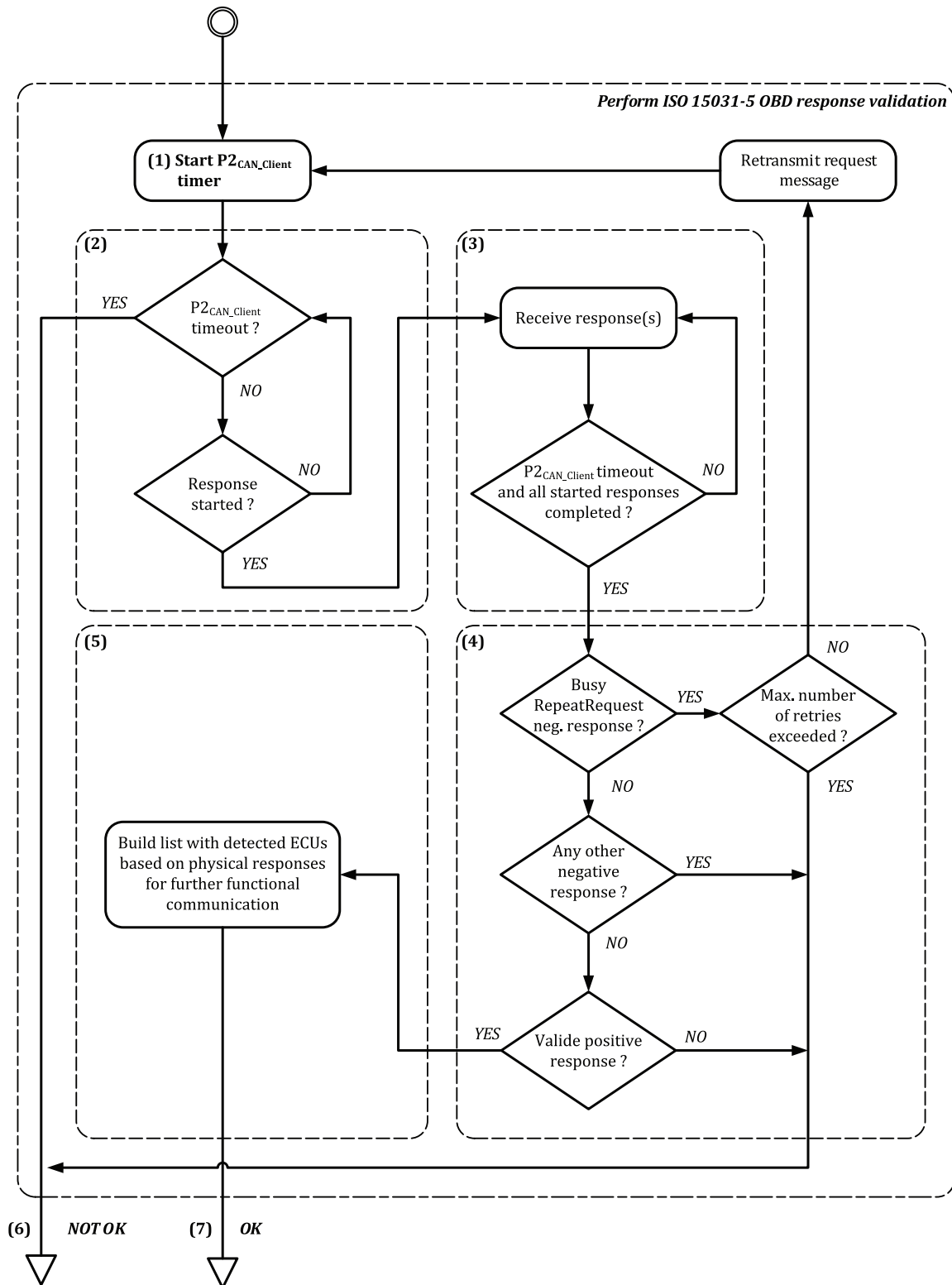

Key

- 1 If the transmission of the previously transmitted request message was successful ("OK"), the external test equipment shall start the P2CAN_Client (see ISO 15031-5) application timer and listen for the physical response CAN identifiers as defined in 10.5.
- 2 If the external test equipment determines a P2CAN timeout and no response message has been started, then the external test equipment has verified that 11 bit or 29 bit CAN identifiers (whichever was used in the previously transmitted request message) are not used for legislated OBD communication. In addition, this means that the external test equipment has determined that the vehicle supports CAN, using the specified physical layer and the currently selected baudrate contained in the baudrateRecord parameter.

3 The start of a response message can either be the reception of a FirstFrame or SingleFrame which uses one of the specified legislated OBD 11 bit or 29 bit CAN identifiers (whichever was used in the former request message). If at least one response message is started, then the external test equipment shall continue to receive this previously started response message (only applies to multiple-frame response messages) and shall accept further response messages, within $P2_{CAN_Client}$, which use one of the specified 11 bit or 29 bit physical response CAN identifiers (whichever was used in the former request message).

4 When all started response messages are completely received (positive and negative responses) and the $P2_{CAN_Client}$ application timer has elapsed, the external test equipment shall analyse whether negative responses have been received.

If one or more of the received response messages are negative responses to the previously transmitted request with response code 21_{16} (busyRepeatRequest), the external test equipment shall restart the response validation procedure at step (1) after a minimum delay of 200 ms. If the negative response(s) appear(s) on six subsequent sequences, the external test equipment shall assume that the vehicle is not compliant with ISO 15031-5. This implies that a legislated OBD-compliant system shall provide a positive response within a maximum of five retries.

Assuming that each negative response with NRC 21_{16} is received shortly before P2 elapses, the total time available for the vehicle to correctly respond results in 1 250 ms.

If a legislated OBD ECU responds with any other negative response code or a legislated OBD ECU responds with a response which cannot be interpreted according to ISO 15031-5, the external test equipment shall assume that the vehicle is not compliant with ISO 15031-5 ("NOT OK").

5 If no negative or invalid response was detected in accordance with step (4), the external test equipment has verified that the vehicle supports 11 bit or 29 bit CAN identifiers (whichever was used in the former request message) for legislated OBD communication. The external test equipment shall build a list of the detected legislated OBD-related ECUs which responded to the request message of service 01_{16} and read supported PIDs based on the received physical responses. This step finishes the initialization sequence and verifies the vehicle's compliance with this part of ISO 15765.

6 If the support of 11 bit CAN identifiers for legislated OBD communication cannot be verified, a functionally addressed request message with service 01_{16} (read supported PIDs) using the legislated OBD 29 bit functional request CAN identifier as defined in 10.5.3, shall be transmitted and the response validation procedure shall be repeated as defined in Figure 4. If no support of 11 bit and 29 bit CAN identifiers for legislated OBD communication can be verified, the detection of WWH-OBD-compliant ECUs shall be performed as specified in Figure 5.

7 Vehicle is compliant with this part of ISO 15765.

Figure 4 — Perform ISO 15031-5 OBD response validation

6.3.2 CAN identifier validation procedure WWH-OBD

A functionally addressed service 22_{16} $F8_{16}$ 10_{16} (protocol identification) request using the legislated WWH-OBD 11 bit functional request CAN identifier, as defined in 10.5.2, shall be transmitted and the response validation procedure shall be performed as defined in Figure 5.

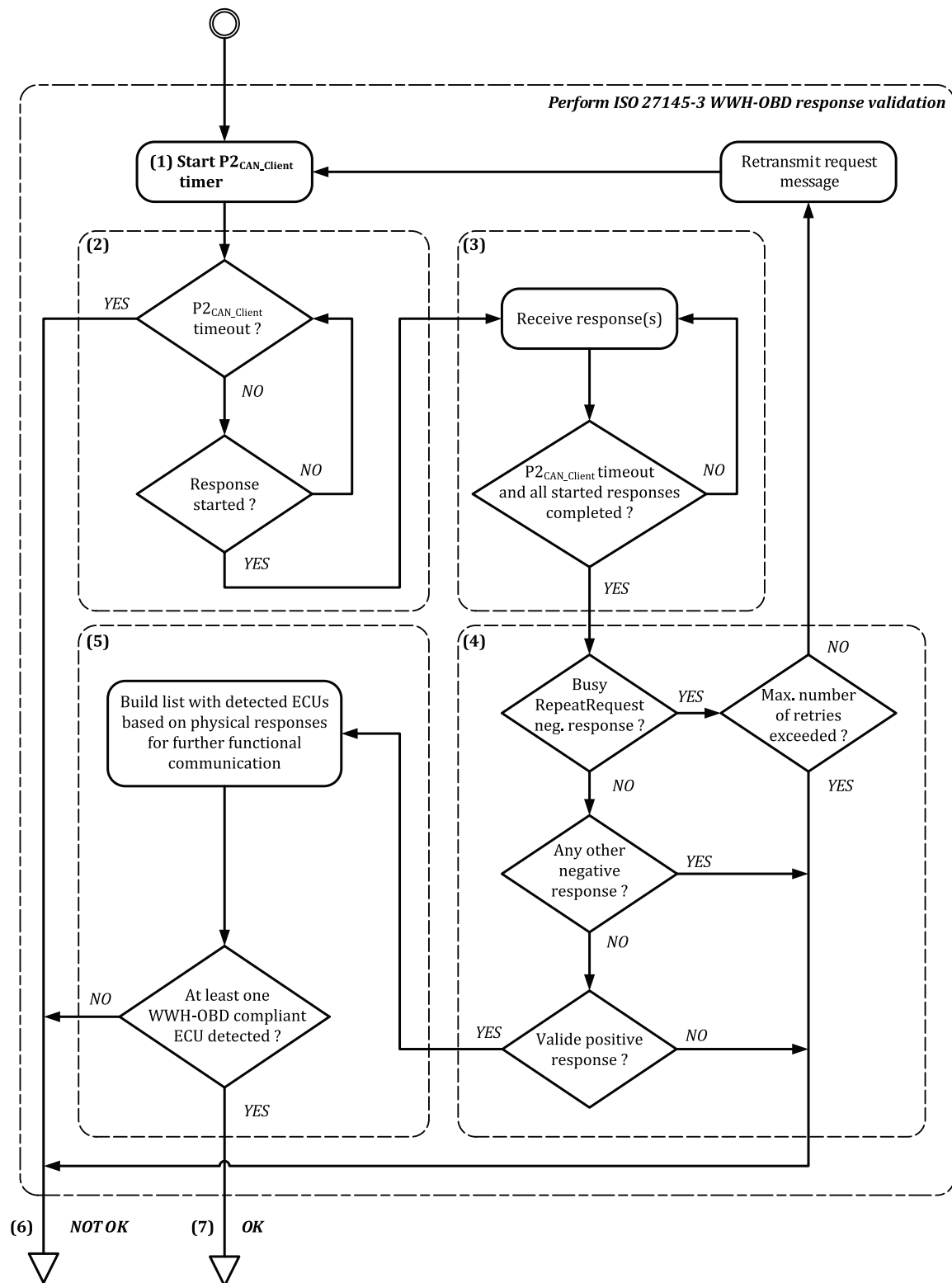

Key

- 1 If the transmission of the previous WWH-OBD request message (as defined in [Figure 2](#)) was successful, the external test equipment shall start the P2CAN_Client (see ISO 27145-3) application timer and listen for the physical response CAN identifiers as defined in [10.5](#).
- 2 If the external test equipment determines a P2CAN timeout, then no response message has been started and the external test equipment has verified that 11 bit or 29 bit CAN identifiers (whichever was used in the previously transmitted request message) are not used for legislated WWH-OBD communication.

- 3 The start of a response message can either be the reception of a FirstFrame or SingleFrame which uses one of the specified legislated WWH-OBD 11 bit or 29 bit CAN identifiers (whichever was used in the former request message). If at least one response message is started, then the external test equipment shall continue to receive this previously started response message (only applies to multiple-frame response messages) and shall accept further response messages, within $P2_{CAN_Client}$, which use one of the specified 11 bit or 29 bit physical response CAN identifiers (whichever was used in the former request message).
- 4 When all started response messages are completely received (positive and negative responses) and the $P2_{CAN_Client}$ application timer has elapsed, the external test equipment shall analyse whether negative responses have been received. If one or more of the received response messages are negative responses to the previously transmitted request messages with response code 21_{16} (busyRepeatRequest), the external test equipment shall restart the response validation procedure at step (1) after a minimum delay of 200 ms. If the negative response(s) appear(s) on six subsequent sequences the external test equipment shall assume that the vehicle is not compliant with ISO 27145-3. This implies that a legislated WWH-OBD-compliant system shall provide a positive response within a maximum of five retries.
Assuming that each negative response with NRC 21_{16} is received shortly before P2 elapses, the total time available for the vehicle to correctly respond results in 1 250 ms.
If a legislated WWH-OBD ECU responds with any other negative response code or a legislated WWH-OBD ECU responds with a response which cannot be interpreted in accordance with ISO 27145-3, the external test equipment shall assume that the vehicle is not compliant with ISO 27145-3.
- 5 If no negative or invalid response was detected in accordance with step (4), the external test equipment has verified that the vehicle supports 11 bit or 29 bit CAN identifiers (whichever was used in the former request message) for legislated WWH-OBD communication. The external test equipment shall build a list of the detected legislated WWH-OBD-related ECUs which responded to the request message of service 22_{16} F810₁₆ and then read supported DIDs based on the received physical responses.
If the list contains at least one WWH-OBD-compliant ECU, the initialization sequence is finished and it is verified that the vehicle is ISO 27145-4 compliant.
If this list does not contain at least one WWH-OBD-compliant ECU, it shall be assumed that the vehicle does not support the CAN identifier used in the previously transmitted request.
- 6 If the support of 11 bit CAN identifiers for legislated WWH-OBD communication cannot be verified ("NOT OK"), a functionally addressed request message with service 22_{16} (read supported PIDs) using the legislated WWH-OBD 29 bit functional request CAN identifier as defined in [10.5.3](#) shall be transmitted. After successful transmission of the request, the external test equipment shall repeat the response validation sequence as specified in [Figure 5](#). If neither a 11 bit nor a 29 bit CAN identifier can be verified as supported, it shall be assumed that the vehicle is not compliant with ISO 27145 ("NOT OK").
- 7 Vehicle is ISO 27145-4 compliant.

Figure 5 — Perform ISO 27145-3 WWH-OBD response validation

7 Application layer

The application layer is the seventh level of the seven-layer [OSI model](#). It interfaces directly to and performs common application services for the application processes. It also issues requests to the presentation layer.

The application layer for the emissions-related diagnostic services shall be implemented as defined in the following:

- legislated OBD: diagnostic services as defined in ISO 15031-5;
- legislated WWH-OBD: diagnostic services as defined in ISO 27145-3.

A vehicle which complies with

- legislated OBD shall respond to ISO 15031-5 requests from the external test equipment, and
- legislated WWH-OBD shall respond to ISO 27145-3 requests from the external test equipment.

The external test equipment shall be capable of supporting a list of detected legislated OBD/WWH-OBD-related ECUs (generated during the initialization sequence as defined in [Clause 6](#)).

8 Session layer

ISO 14229-2 defines the session layer service requirements.

All legislated OBD/WWH-OBD communication shall take place during the default diagnostic session.

There shall always be exactly one diagnostic session active in a legislated OBD-related ECU. A legislated OBD/WWH-OBD ECU shall always start the default diagnostic session when powered up. If no other diagnostic session is started, then the default diagnostic session shall run as long as the legislated OBD/WWH-OBD ECU is powered.

A legislated OBD/WWH-OBD ECU shall be capable of providing all diagnostic functionality defined for legislated OBD/WWH-OBD in the default diagnostic session and under normal operating conditions.

There is no need for any diagnostic service to be sent to the legislated OBD/WWH-OBD ECU(s) to keep the default diagnostic session active.

9 Transport protocol layer

The requirements of ISO 15765-2 are applicable for legislated OBD purposes with the exception that CAN FD is not allowed. In addition, the FirstFrame escape sequence is only allowed when ISO 14229-1 UDS services are used for legislated OBD.

10 Network layer

10.1 General

The network layer of the external test equipment and the legislated OBD/WWH-OBD-compliant vehicle ECU(s) (from the external test equipment point of view) shall be in accordance with ISO 15765-2 and the restrictions/additions given in [10.2](#) to [10.5](#).

10.2 Network layer parameters

10.2.1 Timing parameter values

[Table 2](#) specifies the network layer timing parameters to be used by the external test equipment and the legislated OBD-compliant vehicle (from the external test equipment point of view) for legislated OBD/WWH-OBD communication.

The listed performance requirement values are the binding communication requirements for the external test equipment and the legislated OBD/WWH-OBD ECU(s) considered as being legislated OBD-compliant. The timeout values are defined to be higher than the values for the performance requirements in order to overcome communication conditions where the performance requirement absolutely cannot be met (owing to external conditions such as high bus load).

Table 2 — Network layer timeout and performance requirement values

Parameter	Timeout value	Performance requirement value
N_As / N_Ar	25 ms	—
N_Bs	75 ms	—
N_Br	—	$(N_{Br} + N_{Ar}) < 25 \text{ ms}$
N_Cs	—	$(N_{Cs} + N_{As}) < 50 \text{ ms}$
N_Cr	150 ms	—

NOTE A detailed description of the network layer timing parameter values can be found in ISO 15765-2. Due to application layer timing requirements, the following performance requirement for the transmission of a single frame or the first frame of an ECU response message applies: $P2_{CAN, ECU} + N_{As} \rightarrow P2_{CAN, max}$.

10.2.2 Definition of Flow Control parameter values

10.2.2.1 Flow Control parameters

The BlockSize (BS) and SeparationTime (ST_{min}) parameter values are limited for the external test equipment and the server/ECU. Despite limiting these values, both shall be capable of adapting to any valid parameter in a FlowControl frame.

This implies that the external test equipment shall use these values when transmitting FlowControl frames, but will still need to support the transport protocol as defined in ISO 15765-2.

10.2.2.2 External test equipment

The external test equipment shall use the following network layer parameter values defined in [Table 3](#) for its FlowControl frames sent in response to the reception of a FirstFrame.

Table 3 — External test equipment Flow Control parameter values

Parameter	Name	Value	Description
N_WFT _{max}	WaitFrame Transmission	0	No FlowControl wait frames are allowed for legislated OBD/WWH-OBD. The FlowControl frame sent by the external test equipment following the FirstFrame of an ECU response message shall contain the FlowStatus (FS) set to 0 (ClearToSend), which forces the ECU to start immediately after the reception of the FlowControl frame with the transmission of the ConsecutiveFrame(s).
BS	BlockSize	0	A single FlowControl frame shall be transmitted by the external test equipment for the duration of a segmented message transfer. This unique FlowControl frame shall follow the First Frame of an ECU response message.
ST _{min}	SeparationTime	0	This value allows the ECU to send ConsecutiveFrames, following the FlowControl frame sent by the external test equipment as fast as possible.

If a reduced implementation of the ISO 15765-2 network layer is done in a legislated OBD/WWH-OBD ECU, covering only the above listed FlowControl frame parameter values (BS, ST_{min}), then any FlowControl frame received during legislated OBD/WWH-OBD communication and using different FlowControl frame parameter values as defined in this table, shall be ignored by the receiving legislated OBD/WWH-OBD ECU (treated as an unknown network layer protocol data unit).

10.2.2.3 Legislated WWH-OBD server/ECU

The WWH-OBD server/ECU shall use the network layer parameter values defined in [Table 4](#) for its FlowControl frames sent in response to the reception of a FirstFrame.

Table 4 — Legislated WWH-OBD server/ECU Flow Control parameter values

Parameter	Name	Value	Description
BS	BlockSize	00 ₁₆ .. FF ₁₆	The server/ECU shall select the best value to accommodate the vehicle's network and specifically gateway limitations. It is recommended that a value of zero be used to make the transmission as fast as possible. EXAMPLE If an in-vehicle gateway can buffer eight messages, the BS parameter value should be set to 8 to ensure that the external test equipment will not cause an overflow condition in the gateway's buffer.
ST _{min}	SeparationTime	0...5	This value allows the external test equipment to send ConsecutiveFrames, following the FlowControl frame sent by a server/ ECU, as fast as supported by the WWH-OBD-compliant vehicle's network. The receiving server/ECU shall transmit a value for ST _{min} which can be handled by the vehicle's network and gateway architecture. However, the server/ECU shall be capable of receiving CAN frames of the same transmission with an inter-frame time of zero milliseconds. It must be ensured that vehicle networks and gateways can handle a maximum inter-frame separation time of 5 ms for long data transmissions to the server/ECU.

10.2.3 Maximum number of legislated OBD/WWH-OBD ECUs

10.2.3.1 Legislated OBD/WWH-OBD-related ECUs with 11 bit CAN identifiers

The maximum number of legislated OBD/WWH-OBD-related ECUs with 11 bit CAN identifiers in a vehicle shall not exceed eight. The network layer of the external test equipment shall be capable of receiving segmented data from eight legislated OBD/WWH-OBD ECUs with 11 bit CAN identifiers in parallel.

10.2.3.2 Legislated OBD/WWH-OBD-related ECUs with 29 bit CAN identifiers

Addresses in the ranges defined in [Table 5](#) are available for legislated OBD/WWH-OBD ECUs with 29 bit CAN identifiers. The maximum number of legislated OBD/WWH-OBD ECUs with 29 bit CAN identifiers, which respond to external test equipment compliant to either ISO 15031-4/SAE, J1978 or ISO 27145-6 requests, is only limited by the available address ranges as defined in [Table 5](#) and response message timing performance (P2_{Client_max}) requirements.

The physical ECU diagnostic address ('XX₁₆') of an ECU embedded in the physical CAN identifiers shall be unique for an ECU in a given vehicle.

Table 5 — Physical ECU diagnostic addresses/ranges for 29 bit CAN identifiers

Address ('XX ₁₆ ')/range	Description
00 ₁₆ - 32 ₁₆	Vehicle manufacturer reserved address range
34 ₁₆ - EF ₁₆	Vehicle manufacturer reserved address range

NOTE The addresses/ranges defined in [Table 5](#) may also be used for ECUs which are not subject to legislative requirements.

10.3 Addressing formats

10.3.1 Normal and fixed addressing format

For legislated OBD/WWH-OBD communication, the following shall be used:

- only the normal addressing format (as defined in ISO 15765-2), in the case of 11 bit CAN identifiers;
- only the normal fixed addressing format (as defined in ISO 15765-2), in the case of 29 bit CAN identifiers.

10.3.2 Functional addressing

Functional addressed services require that the data content does not exceed the single frame limitation as defined in ISO 15765-2.

Figure 6 illustrates the functional request CAN identifier usage and related response.

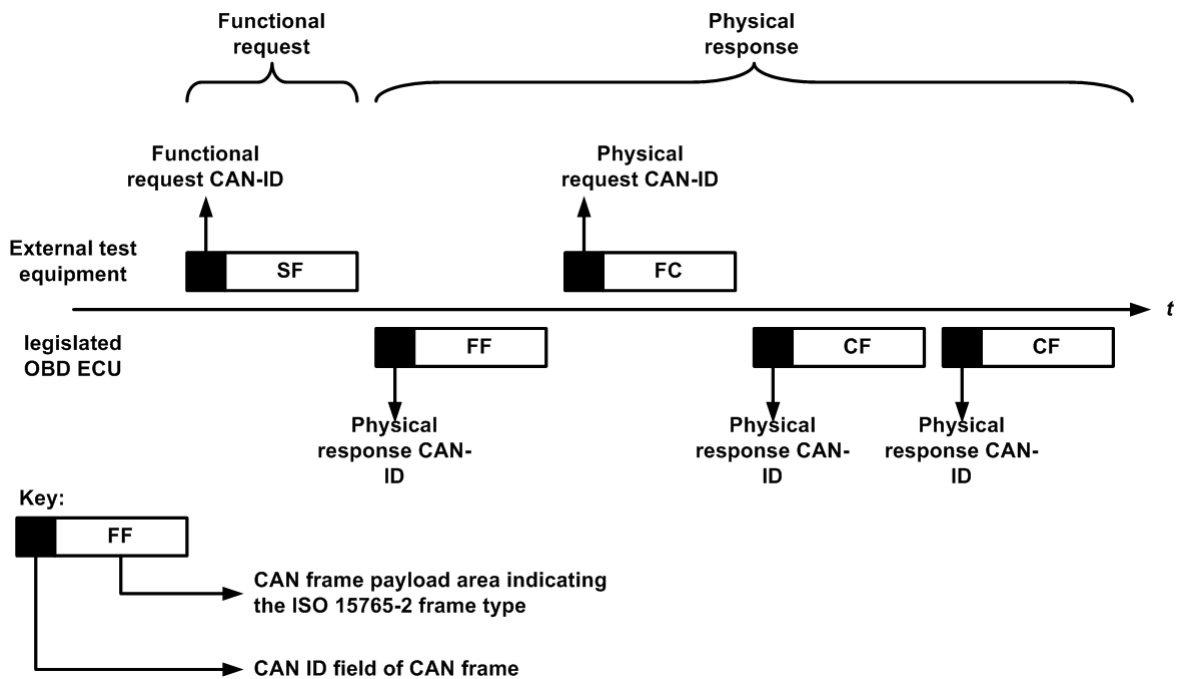

Figure 6 — Functional request CAN identifier usage

10.3.3 Physical addressing

Each WWH-OBD-related server/ECU shall be capable of receiving physically addressed messages on the network layer up to the maximum supported message length as defined in ISO 27145-3. This requirement does not apply to ISO 15031-5-related request messages.

The external test equipment shall be capable of transmitting physically addressed request messages on the WWH-OBD-compliant network layer up to the maximum supported message length as defined in ISO 27145-3.

NOTE This implies that all services as defined in Figure 7 can be transmitted as physical requests.

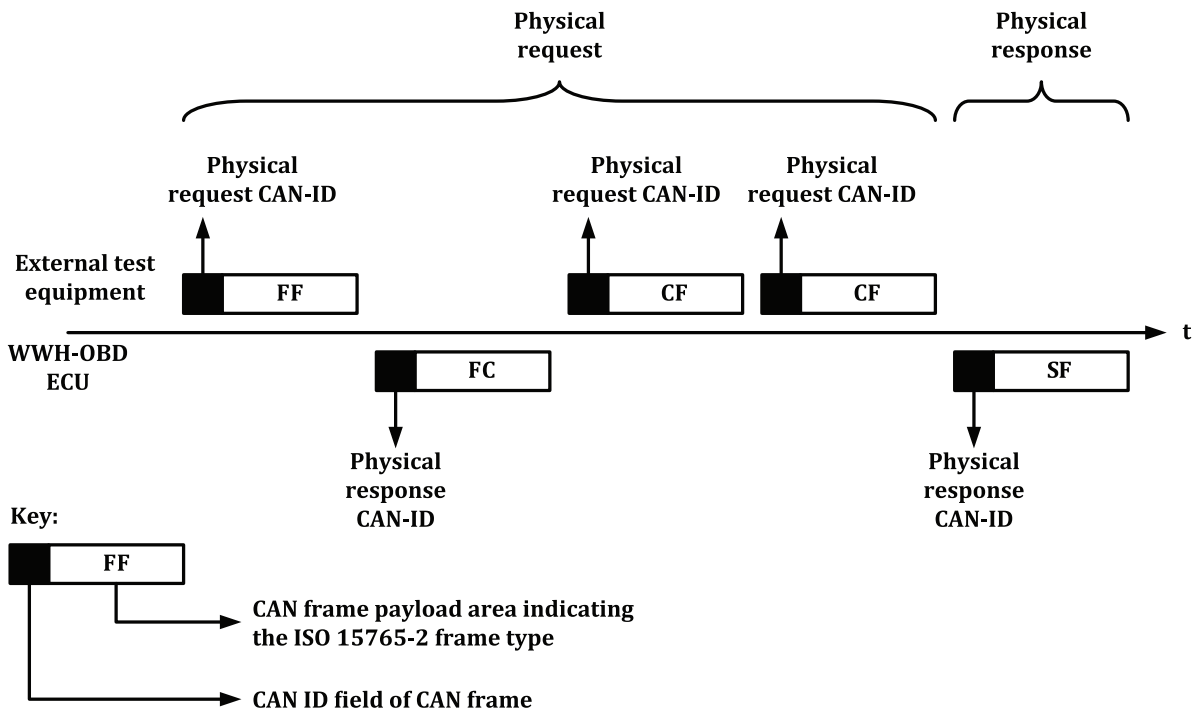

Figure 7 — Physical request CAN identifier usage

10.4 CAN identifier requirements

10.4.1 External test equipment

The external test equipment shall support 11 bit and 29 bit CAN identifiers for legislated OBD/WWH-OBD communication, for which it shall only accept CAN identifiers which fit into the defined legislated OBD/WWH-OBD CAN identifier ranges for 11 bit or 29 bit CAN identifiers (see 10.5).

10.4.2 Legislated OBD/WWH-OBD server/ECU

From the external test equipment point of view, each legislated OBD/WWH-OBD ECU in a given legislated OBD/WWH-OBD-compliant vehicle shall

- support either 11 bit or 29 bit CAN identifiers for legislated OBD/WWH-OBD request and response messages;
- support one pair of physical request and response CAN identifiers in accordance with 10.5;
- accept the functional request CAN identifier of the supported CAN identifier set (11 bit or 29 bit, see 10.5) for functionally addressed legislated OBD/WWH-OBD request messages;
- accept the physical request CAN identifier associated with the physical response CAN identifier for physically addressed FlowControl frames sent by the external test equipment (see 10.5);
- accept the physical request CAN identifier for physically addressed SingleFrames or FirstFrames frames of the legislated OBD/WWH-OBD request messages sent by the external test equipment (see 10.5).

10.5 Mapping of diagnostic addresses

10.5.1 Legislated OBD/WWH-OBD CAN identifiers

The following subclauses specify the 11 bit and 29 bit CAN identifiers to be used for legislated OBD/WWH-OBD diagnostics. Both sets of CAN identifiers represent the mapping of diagnostic addresses into CAN identifiers as follows. [Table 6](#) defines the diagnostic addresses versus type of CAN identifier, whether physical or functional. For 11 bit CAN identifiers, the mapping of the target address (TA) and source address (SA) into a CAN identifier is implied. [Table 7](#) specifies the 11 bit CAN identifiers to be used for legislated OBD/WWH-OBD diagnostics.

Table 6 — Definition of diagnostic addresses versus type of CAN identifier

CAN identifier	Target address (TA)	Source address (SA)	TA type (TAtype)	Message type (Mtype)
Functional request	Legislated OBD/WWH-OBD system = 33_{16}	External test equipment = $F1_{16}$	functional	diagnostics
Physical response	External test equipment = $F1_{16}$	Legislated OBD/WWH-OBD ECU = XX_{16}	physical	diagnostics
Physical request	Legislated OBD/WWH-OBD ECU = XX_{16}	External test equipment = $F1_{16}$	physical	diagnostics
XX ₁₆ ECU physical diagnostic address.				
NOTE For detailed descriptions of parameters TA, SA, TAtype and Mtype, see ISO 15765-2.				

For legislated OBD/WWH-OBD:

- the functional request CAN identifier shall be used for functionally addressed request messages sent by the external test equipment. This particular CAN identifier represents the TA 33_{16} (legislated OBD/WWH-OBD functional system) and SA $F1_{16}$ (external test equipment);
- the physical response CAN identifier shall be used for physically addressed response messages sent by the legislated OBD/WWH-OBD ECU(s). This particular CAN identifier represents TA $F1_{16}$ (external test equipment) and the physical diagnostic address (SA) of the ECU(s);
- the physical request CAN identifier shall be used for physically addressed request messages and for all FlowControl frames sent by the external test equipment. This particular CAN identifier represents the physical diagnostic address (TA) of the ECU and SA $F1_{16}$ (external test equipment).

The server identifier (physical diagnostic address) of a legislated OBD/WWH-OBD ECU shall be unique to a given legislated OBD/WWH-OBD-compliant vehicle.

The CAN identifiers specified for legislated OBD/WWH-OBD may also be used for enhanced diagnostics if this usage does not interfere with legislated OBD/WWH-OBD.

10.5.2 11 bit CAN identifiers

[Table 7](#) specifies the 11 bit CAN identifiers for legislated OBD/WWH-OBD, based on the defined mapping of the diagnostic addresses.

Table 7 — 11 bit legislated OBD/WWH-OBD CAN identifiers

CAN identifier	Description
7DF ₁₆	CAN identifier for functionally addressed request messages sent by external test equipment
7E0 ₁₆	Physical request CAN identifier from external test equipment to ECU #1
7E8 ₁₆	Physical response CAN identifier from ECU #1 to external test equipment
7E1 ₁₆	Physical request CAN identifier from external test equipment to ECU #2
7E9 ₁₆	Physical response CAN identifier from ECU #2 to external test equipment
7E2 ₁₆	Physical request CAN identifier from external test equipment to ECU #3
7EA ₁₆	Physical response CAN identifier from ECU #3 to external test equipment
7E3 ₁₆	Physical request CAN identifier from external test equipment to ECU #4
7EB ₁₆	Physical response CAN identifier ECU #4 to the external test equipment
7E4 ₁₆	Physical request CAN identifier from external test equipment to ECU #5
7EC ₁₆	Physical response CAN identifier from ECU #5 to external test equipment
7E5 ₁₆	Physical request CAN identifier from external test equipment to ECU #6
7ED ₁₆	Physical response CAN identifier from ECU #6 to external test equipment
7E6 ₁₆	Physical request CAN identifier from external test equipment to ECU #7
7EE ₁₆	Physical response CAN identifier from ECU #7 to external test equipment
7E7 ₁₆	Physical request CAN identifier from external test equipment to ECU #8
7EF ₁₆	Physical response CAN identifier from ECU #8 to external test equipment

While not required for current implementations, it is strongly recommended (and may be required by applicable legislation) that for future implementations, the following 11 bit CAN identifier assignments be used:

- 7E0₁₆/7E8₁₆ for ECM (engine control module);
- 7E1₁₆/7E9₁₆ for TCM (transmission control module).

10.5.3 29 bit CAN identifiers

Tables 8 and 9 specify the 29 bit CAN identifiers for legislated OBD/WWH-OBD, based on the defined mapping of the diagnostic addresses. The 29 bit CAN identifiers shall comply with the normal fixed addressing format according to ISO 15765-2, summarized in Table 8.

Table 8 — Summary of 29 bit CAN identifier format — Normal fixed addressing

CAN ID bit position	28 .. 24	23 .. 16	15 .. 8	7 .. 0
Functional CAN identifier	18 ₁₆	DB ₁₆	TA	SA
Physical CAN identifier	18 ₁₆	DA ₁₆	TA	SA

Table 9 — 29 bit legislated OBD/WWH-OBD CAN identifiers

CAN identifier	Description
18 ₁₆ DB ₁₆ 33 ₁₆ F1 ₁₆	Functional request CAN identifier from external test equipment to ECUs with #33 ₁₆
18 ₁₆ DA ₁₆ XX ₁₆ F1 ₁₆	Physical request CAN identifier from external test equipment to ECU #XX ₁₆
18 ₁₆ DA ₁₆ F1 ₁₆ XX ₁₆	Physical response CAN identifier from ECU #XX ₁₆ to external test equipment

While not required for current implementations, it is strongly recommended (and may be required by applicable legislation) that for future implementations, the physical ECU addresses be used in accordance with the assignments found in SAE J2178/1.

The physical ECU diagnostic address of an ECU ('XX₁₆') embedded in the physical CAN identifiers shall be unique for a legislated OBD/WWH-OBD ECU in a given vehicle.

10.6 Support of ECUNAME reporting

Each legislated OBD-compliant server/ECU, which responds to external test equipment compliant to either ISO 15031-4/SAE J1978 or ISO 27145-6 requests, is required to support the InfoType "ECUNAME" (see SAE J1979-DA). The mapping between a server/ECU address and the name (ECUNAME) of the server/ECU shall be performed by the external test equipment. This requirement is intended to replace the recommendation from Table 8 referencing SAE J2178.

11 Data link layer

All of ISO 11898-1 is applicable for legislated OBD/WWH-OBD purposes, with the following restrictions/additions. The external test equipment CAN controller shall be able to transmit and receive 11 bit and 29 bit CAN identifiers (see [10.2](#)).

The CAN DLC (data length code) contained in every diagnostic CAN frame shall always be set to 8. The unused data bytes of a CAN frame are undefined. Any diagnostic CAN frame with a DLC value less than 8 shall be ignored by the receiving entity.

12 Physical layer

12.1 General

The physical layer and physical signalling of the external test equipment shall be in accordance with ISO 11898-1 and ISO 11898-2, with the restrictions and additions as specified in [12.2](#) through [12.4](#).

12.2 External test equipment baudrates

The external test equipment shall support the legislated OBD/WWH-OBD baudrates. These can vary because of legislation. Where the applicable legislation does not specify baudrates, use

- a) 250 kBit/s, or
- b) 500 kBit/s.

12.3 External test equipment CAN bit timing

12.3.1 CAN bit timing parameter values

The specified CAN bit timing parameter values apply to the external test equipment. The legislated OBD/WWH-OBD-compliant vehicle may use different CAN bit timing parameter values to achieve its legislated OBD/WWH-OBD-compliant baudrate, however, it shall be able to communicate with the defined external test equipment.

The following specifies the required CAN bit timing parameter settings for the external test equipment based on the timing parameter definitions given in ISO 11898-1. All requirements are specified for operation at 250 kBit/s and 500 kBit/s. The bit timing is according to ISO 11898-1. The CAN controller shall support the protocol specifications CAN 2.0A (standard format) and CAN 2.0B passive (29 bit ID extended format) and shall be in accordance with ISO 11898-1.

For example, the enhanced protocol for higher clock tolerance shall be supported (e.g. tolerate 2 bit message intermission) and extended frame messages shall not be disturbed unless bit errors are detected.

The CAN bit timing parameter values used in this part of ISO 15765-2 are based on equivalent terms in ISO 11898-1:

- t_{SYNCSEG} = Sync_Seg = $1 \times t_Q$,
- t_{SEG1} = Prop_Seg + Phase_Seg1 = $t_{\text{BIT}} - t_{\text{SYNCSEG}} - t_{\text{SEG2}}$,
- t_{SEG2} = Phase_Seg2,
- t_{SJW} = resynchronization jump width,
- t_{BIT} = t_B (nominal bit time),
- t_Q = time quantum,
- SP = nominal sample point position = $(1 - t_{\text{SEG2}}/t_{\text{BIT}}) \times 100 \%$.

Compliance with the nominal bit time tolerance requirement given in this part of ISO 15765 is directly dependent on the CAN system clock tolerance of the external test equipment and the programmed nominal bit time value. In a typical CAN controller, the nominal bit time value must be an integer multiple of its system clock periods. When the programmable nominal bit time value is set exactly to the required nominal bit time value, accuracy is only affected by the system clock tolerance. Otherwise, the accuracy is dependent upon both the deviation of the programmed bit time value from the nominal bit time value and the system clock tolerance. The contributions from drift or ageing of the system clock source and from the inability to achieve the desired nominal bit time value are additive. The bit time tolerance specification must be met after consideration of both.

Figure 8 illustrates the partitioning of the CAN bit time.

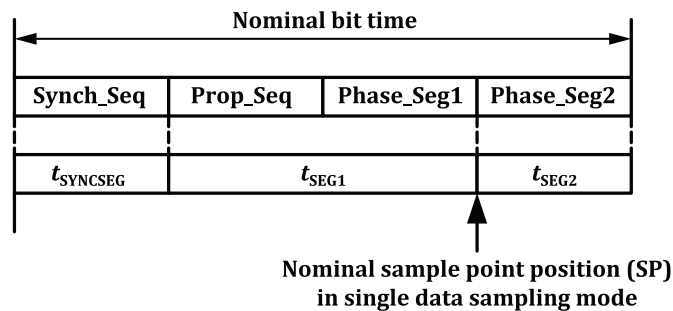

Figure 8 — Partitioning of CAN bit time

12.3.2 Nominal baudrate 250 kBit/s

Table 10 specifies the allowed CAN bit timing parameter values for a baudrate of 250 kBit/s. The external test equipment shall operate in single data sampling mode.

The tolerance of the external test equipment nominal baudrate 250 kBit/s shall be $\pm 0,15 \%$.

Table 10 — 250 kBit/s CAN bit timing parameter values — Single data sampling mode

Parameter	Minimum	Nominal	Maximum
$t_{\text{BIT_RX}}$	3 980 ns	4 000 ns	4 020 ns
$t_{\text{BIT_TX}}$	3 994 ns	4 000 ns	4 006 ns
t_Q	—	—	250 ns
Δf	—	—	0,15 %

The minimum and maximum values of the nominal bit time $t_{\text{BIT_RX}}$ are worst-case values for the reception of bits from the CAN bus based on a nominal baudrate tolerance of $\pm 0,5 \%$.

The minimum and maximum values of the nominal bit time $t_{\text{BIT_TX}}$ are worst-case values for the transmission of bits onto the CAN bus based on the specified external test equipment nominal baudrate tolerance of $\pm 0,15 \%$.

[Table 11](#) presents the only allowed CAN bit timing parameter values for the external test equipment based on standard time quanta (t_Q) and the timing parameters listed in [12.3.1](#).

Table 11 — 250 kBit/s CAN bit timing parameter values for standard time quanta

t_Q	t_{SJW}	t_{SEG1}	t_{SEG2}	Nominal sample point position
ns	ns	ns	ns	%
200	600	3 000	800	80
250	750	3 000	750	81,25

The nominal sample point position is specified relative to one bit time.

12.3.3 Nominal baudrate 500 kBit/s

[Table 12](#) specifies the allowed CAN bit timing parameter values for a baudrate of 500 kBit/s. The external test equipment shall operate in single data-sampling mode. The tolerance of the external test equipment nominal baudrate 500 kBit/s shall be $\pm 0,15$ %.

Table 12 — 500 kBit/s CAN bit timing parameter values — Single data sampling mode

Parameter	Minimum	Nominal	Maximum
t_{BIT_RX}	1 990 ns	2 000 ns	2 010 ns
t_{BIT_TX}	1 997 ns	2 000 ns	2 003 ns
t_Q	—	—	125 ns
Δf	—	—	0,15 %

The minimum and maximum values of the nominal bit time t_{BIT_RX} are worst-case values for the reception of bits from the CAN bus based on a nominal baudrate tolerance of $\pm 0,5$ %.

The minimum and maximum values of the nominal bit time t_{BIT_TX} are worst-case values for the transmission of bits onto the CAN bus based on the specified external test equipment nominal baudrate tolerance of $\pm 0,15$ %.

[Table 13](#) presents the only allowed CAN bit timing parameter values for the external test equipment based on standard time quanta (t_Q) and the timing parameters listed in [12.3.1](#).

Table 13 — 500 kBit/s CAN bit timing parameter values for standard time quanta

t_Q	t_{SJW}	t_{SEG1}	t_{SEG2}	Nominal sample point position
ns	ns	ns	ns	%
100	300	1 500	400	80
125	375	1 500	375	81,25

The nominal sample point position is specified relative to one bit time.

12.4 External test equipment

12.4.1 General

The following specifies the electrical parameters to be fulfilled by the external test equipment. The requirements are separated into those for the external test equipment CAN interface and those for the external test equipment cable.

[Figure 9](#) illustrates the external test equipment electrical parameters.

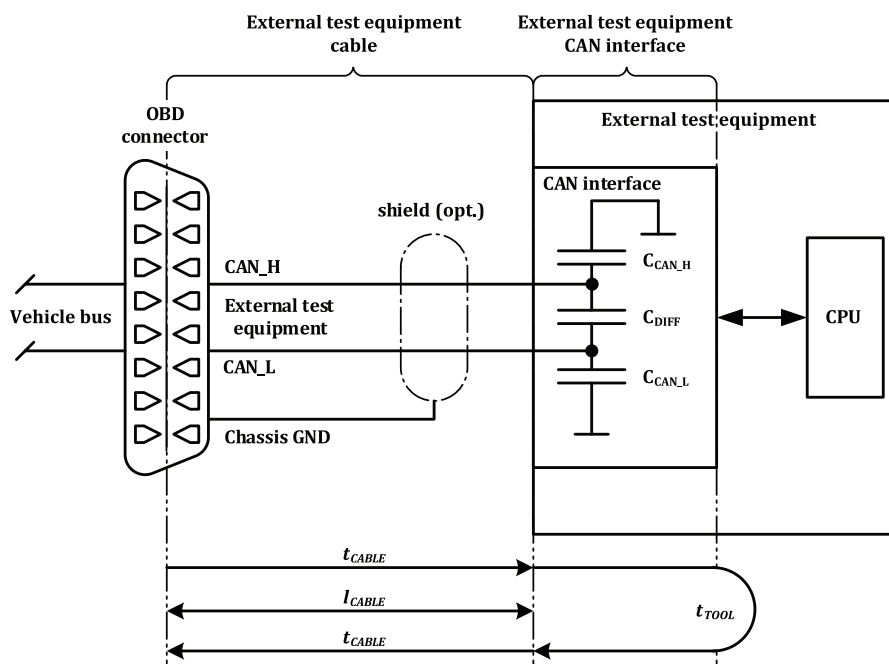

NOTE The requirement for cable shielding is specified in [12.4.3.3](#).

Figure 9 — External test equipment electrical parameters

12.4.2 CAN interface

12.4.2.1 Capacitive load

[12.4.2](#) through [12.4.3](#) specify the required electrical parameters for the external-test-equipment CAN interface, excluding the cable (see [12.4.3](#)) and the OBD/WWH-OBD connector.

The external test equipment capacitive load does not include the capacitive load of the external-test-equipment cable. These values only apply to the CAN interface of the external test equipment hardware, with the exception of the a.c. termination (see [12.4.2.3.3](#)), and are seen during the recessive state when the external test equipment is disconnected from the cable and the a.c. termination has not yet been inserted (see [Table 14](#)).

Table 14 — External test equipment capacitive load — Without cable capacitive load

Parameter	Minimum	Nominal	Maximum pF	Description
C_{DIFF}	—	—	50	CAN_H to CAN_L
C_{CAN_H}, C_{CAN_L}	—	—	100	CAN_H/CAN_L to ground potential

12.4.2.2 Propagation delay

The external test equipment propagation delay does not include the cable propagation delay. This value only applies to the CAN interface of the external-test-equipment hardware. This requirement is based on the most critical timing when operating at the legislated OBD/WWH-OBD-compliant baud rate of 500 kBit/s. The external-test-equipment propagation delay (loop delay) includes all delays that can be caused by the CAN interface of the external test equipment (e.g. CAN transceiver propagation delays, CAN controller propagation delays. See [Table 15](#)).

Table 15 — External test equipment propagation delay — Loop delay without cable delay

Parameter	Minimum	Nominal	Maximum ns	Description
t_{TOOL}	—	—	390	Loop delay of external test equipment

12.4.2.3 CAN bus termination

12.4.2.3.1 General

This subclause specifies the termination requirements to be fulfilled by the external test equipment.

[Figure 10](#) illustrates the external test equipment CAN bus a.c. termination.

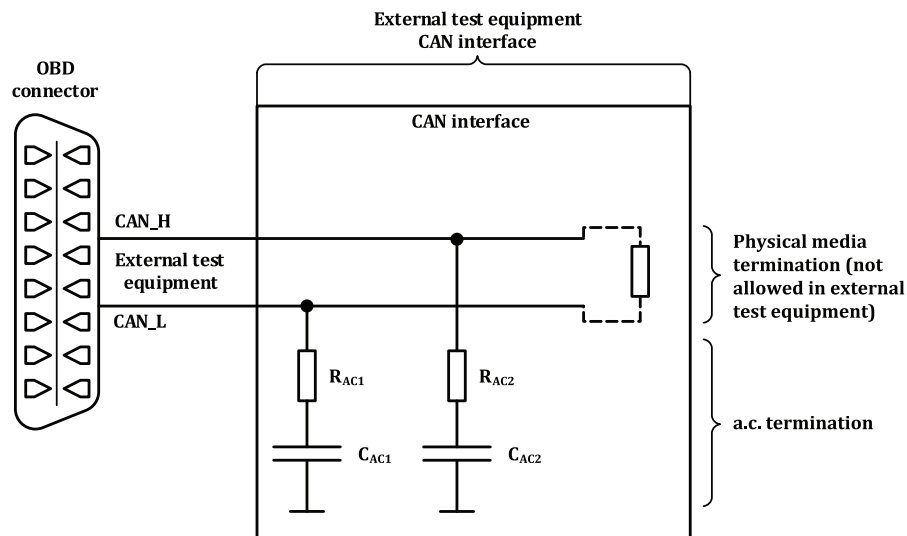

Figure 10 — External test equipment CAN bus a.c. termination

12.4.2.3.2 Physical media termination

There shall not be any termination resistor between the CAN conductors CAN_H and CAN_L in the external test equipment for the adaptation to the physical media impedance. The external test equipment shall be an unterminated node on the CAN bus to which it is connected.

12.4.2.3.3 a.c. termination

The external test equipment shall have an a.c. termination for the purpose of minimizing reflections on the CAN bus. See [Table 16](#).

NOTE Reflections on the CAN bus occur in the external test equipment CAN interface because it is not permitted that the external test equipment use a physical media termination resistor to adapt to the physical media impedance (see [12.4.2.3.2](#)).

Table 16 — External-test-equipment a.c. termination parameters

Parameter	Minimum	Nominal	Maximum	Description
R_1, R_2	90 Ω	100 Ω	110 Ω	Resistor of the a.c. termination
C_1, C_2	470 pF	560 pF	640 pF	Capacitor of the a.c. termination
$R_1 = R_2$				
$C_1 = C_2$				

12.4.3 External test equipment cable

12.4.3.1 Cable length

The external test equipment cable shall provide interconnection between the vehicle's OBD/WWH-OBD connector and the CAN interface of the external test equipment (see 12.4.2).

The external test equipment cable length is defined to be the length of the cable between the vehicle's OBD/WWH-OBD connector and the external test equipment CAN interface (see Table 17).

Table 17 — External-test-equipment cable length

Parameter	Minimum	Nominal	Maximum m	Description
l_{CABLE}	—	—	5	External test equipment cable length

12.4.3.2 Propagation delay

The cable propagation delay shall not include the external test equipment propagation delay. This value only applies to the cable. This requirement is based on the most critical timing when operating at the legislated OBD/WWH-OBD-compliant baudrate of 500 kBit/s. The cable propagation delay is defined as a one-way delay, from the OBD/WWH-OBD connector to the external test equipment CAN interface (see Table 18).

Table 18 — External-test-equipment cable propagation delay

Parameter	Minimum	Nominal	Maximum ns	Description
t_{CABLE}	—	—	27.5	External test equipment cable delay

12.4.3.3 Cable configuration requirements

The following configuration requirements apply to the external test equipment cable.

- No other wires shall be twisted with CAN conductor(s) CAN_H or CAN_L. However, twisting of the CAN conductors with Signal Ground is allowed.

NOTE There are no further requirements for twisting.

- The CAN_H and CAN_L conductors shall have the same length and traverse the same path for the entire distance.
- CAN_H and CAN_L conductors shall not be included in a bundle containing radiating wires which induce more than 0,5 V noise modulation on either CAN conductor relative to Signal Ground;
- The cable shall be shielded where the external-test-equipment cable length exceeds 1 m. The shield shall be connected to the chassis ground pin of the cable side of the OBD/WWH-OBD connector.

Bibliography

- [1] ISO 7498-2, *Information processing systems — Open Systems Interconnection — Basic Reference Model — Part 2: Security Architecture*
- [2] ISO 11898-3, *Road vehicles — Controller area network (CAN) — Part 3: Low-speed, fault-tolerant, medium-dependent interface*
- [3] ISO 14229-1, *Road vehicles — Unified diagnostic services (UDS) — Part 1: Specification and requirements*
- [4] ISO 14229-2, *Road vehicles — Unified diagnostic services (UDS) — Part 2: Session layer services*
- [5] ISO 14229-3, *Road vehicles — Unified diagnostic services (UDS) — Part 3: Unified diagnostic services on CAN implementation (UDSonCAN)*
- [6] ISO 15031-2, *Road vehicles — Communication between vehicle and external equipment for emissions-related diagnostics — Part 2: Guidance on terms, definitions, abbreviations and acronyms*
- [7] ISO 15031-3, *Road vehicles — Communication between vehicle and external equipment for emissions-related diagnostics — Part 3: Diagnostic connector and related electrical circuits, specification and use*
- [8] ISO 15031-6, *Road vehicles — Communication between vehicle and external equipment for emissions-related diagnostics — Part 6: Diagnostic trouble code definitions*
- [9] ISO 15765-1, *Road vehicles — Diagnostic communication over Controller Area Network (DoCAN) — Part 1: General information and use case definition*
- [10] ISO 27145-2, *Road vehicles — Implementation of World-Wide Harmonized On-Board Diagnostics (WWH-OBD) communication requirements — Part 2: Common data dictionary*
- [11] ISO/IEC 7498-1, *Information technology — Open Systems Interconnection — Basic Reference Model: The Basic Model — Part 1*
- [12] ISO/IEC 7498-3, *Information technology — Open Systems Interconnection — Basic Reference Model: Naming and addressing — Part 3*
- [13] ISO/IEC 7498-4, *Information processing systems — Open Systems Interconnection — Basic Reference Model — Part 4: Management framework*
- [14] ISO/IEC 10731:1994, *Information technology — Open Systems Interconnection — Basic Reference Model — Conventions for the definition of OSI services*
- [15] SAE J1930-DA, *Digital Annex of Electrical/Electronic Systems Diagnostic Terms, Definitions, Abbreviations, and Acronyms*
- [16] SAE J1939, *Recommended Practice for a Serial Control and Communications Vehicle Network*
- [17] SAE J1939-73, *Application Layer Diagnostics*
- [18] SAE J1979-DA, *Digital Annex of E/E Diagnostic Test Modes*
- [19] SAE J2012-DA, *Digital Annex of Diagnostic Trouble Code Definitions and Failure Type Byte Definitions*
- [20] SAE J2178-1, *Class B data communication network messages detailed header formats and physical address assignments*

British Standards Institution (BSI)

BSI is the national body responsible for preparing British Standards and other standards-related publications, information and services.

BSI is incorporated by Royal Charter. British Standards and other standardization products are published by BSI Standards Limited.

About us

We bring together business, industry, government, consumers, innovators and others to shape their combined experience and expertise into standards-based solutions.

The knowledge embodied in our standards has been carefully assembled in a dependable format and refined through our open consultation process. Organizations of all sizes and across all sectors choose standards to help them achieve their goals.

Information on standards

We can provide you with the knowledge that your organization needs to succeed. Find out more about British Standards by visiting our website at bsigroup.com/standards or contacting our Customer Services team or Knowledge Centre.

Buying standards

You can buy and download PDF versions of BSI publications, including British and adopted European and international standards, through our website at bsigroup.com/shop, where hard copies can also be purchased.

If you need international and foreign standards from other Standards Development Organizations, hard copies can be ordered from our Customer Services team.

Subscriptions

Our range of subscription services are designed to make using standards easier for you. For further information on our subscription products go to bsigroup.com/subscriptions.

With **British Standards Online (BSOL)** you'll have instant access to over 55,000 British and adopted European and international standards from your desktop. It's available 24/7 and is refreshed daily so you'll always be up to date.

You can keep in touch with standards developments and receive substantial discounts on the purchase price of standards, both in single copy and subscription format, by becoming a **BSI Subscribing Member**.

PLUS is an updating service exclusive to BSI Subscribing Members. You will automatically receive the latest hard copy of your standards when they're revised or replaced.

To find out more about becoming a BSI Subscribing Member and the benefits of membership, please visit bsigroup.com/shop.

With a **Multi-User Network Licence (MUNL)** you are able to host standards publications on your intranet. Licences can cover as few or as many users as you wish. With updates supplied as soon as they're available, you can be sure your documentation is current. For further information, email bsmusales@bsigroup.com.

Revisions

Our British Standards and other publications are updated by amendment or revision.

We continually improve the quality of our products and services to benefit your business. If you find an inaccuracy or ambiguity within a British Standard or other BSI publication please inform the Knowledge Centre.

Copyright

All the data, software and documentation set out in all British Standards and other BSI publications are the property of and copyrighted by BSI, or some person or entity that owns copyright in the information used (such as the international standardization bodies) and has formally licensed such information to BSI for commercial publication and use. Except as permitted under the Copyright, Designs and Patents Act 1988 no extract may be reproduced, stored in a retrieval system or transmitted in any form or by any means – electronic, photocopying, recording or otherwise – without prior written permission from BSI. Details and advice can be obtained from the Copyright & Licensing Department.

Useful Contacts:

Customer Services

Tel: +44 845 086 9001

Email (orders): orders@bsigroup.com

Email (enquiries): cservices@bsigroup.com

Subscriptions

Tel: +44 845 086 9001

Email: subscriptions@bsigroup.com

Knowledge Centre

Tel: +44 20 8996 7004

Email: knowledgecentre@bsigroup.com

Copyright & Licensing

Tel: +44 20 8996 7070

Email: copyright@bsigroup.com

BSI Group Headquarters

389 Chiswick High Road London W4 4AL UK