



BSI Standards Publication

Carbonaceous materials for the production of aluminium — Cathode block materials

Part 2: Determination of the expansion due to sodium penetration without application of pressure

National foreword

This British Standard is the UK implementation of ISO 15379-2:2015. It supersedes BS ISO 15379-2:2004 which is withdrawn.

The UK participation in its preparation was entrusted to Technical Committee CII/24, Raw materials for the aluminium industry.

A list of organizations represented on this committee can be obtained on request to its secretary.

This publication does not purport to include all the necessary provisions of a contract. Users are responsible for its correct application.

© The British Standards Institution 2015. Published by BSI Standards Limited 2015

ISBN 978 0 580 87019 4

ICS 71.100.10

Compliance with a British Standard cannot confer immunity from legal obligations.

This British Standard was published under the authority of the Standards Policy and Strategy Committee on 31 May 2015.

Amendments issued since publication

Date	Text affected
------	---------------

**Carbonaceous materials for the
production of aluminium — Cathode
block materials —**

Part 2:
**Determination of the expansion
due to sodium penetration without
application of pressure**

*Produits carbonés utilisés pour la production de l'aluminium — Blocs
cathodiques —*

*Partie 2: Détermination de l'expansion due à la pénétration du
sodium sans application de pression*





COPYRIGHT PROTECTED DOCUMENT

© ISO 2015, Published in Switzerland

All rights reserved. Unless otherwise specified, no part of this publication may be reproduced or utilized otherwise in any form or by any means, electronic or mechanical, including photocopying, or posting on the internet or an intranet, without prior written permission. Permission can be requested from either ISO at the address below or ISO's member body in the country of the requester.

ISO copyright office
Ch. de Blandonnet 8 • CP 401
CH-1214 Vernier, Geneva, Switzerland
Tel. +41 22 749 01 11
Fax +41 22 749 09 47
copyright@iso.org
www.iso.org

Contents

Page

Foreword	iv
Introduction	v
1 Scope	1
2 Normative references	1
3 Principle	1
4 Apparatus	1
5 Reagents	2
6 Sampling	2
7 Procedure	3
8 Results	3
8.1 Calculation.....	3
8.2 Precision.....	3
9 Test report	4

Foreword

ISO (the International Organization for Standardization) is a worldwide federation of national standards bodies (ISO member bodies). The work of preparing International Standards is normally carried out through ISO technical committees. Each member body interested in a subject for which a technical committee has been established has the right to be represented on that committee. International organizations, governmental and non-governmental, in liaison with ISO, also take part in the work. ISO collaborates closely with the International Electrotechnical Commission (IEC) on all matters of electrotechnical standardization.

The procedures used to develop this document and those intended for its further maintenance are described in the ISO/IEC Directives, Part 1. In particular the different approval criteria needed for the different types of document should be noted. This document was drafted in accordance with the editorial rules of the ISO/IEC Directives, Part 2 (see www.iso.org/directives).

Attention is drawn to the possibility that some of the elements of this document may be the subject of patent rights. ISO and IEC shall not be held responsible for identifying any or all such patent rights. Details of any patent rights identified during the development of the document will be in the Introduction and/or on the ISO list of patent declarations received (see www.iso.org/patents).

Any trade name used in this document is information given for the convenience of users and does not constitute an endorsement.

For an explanation on the meaning of ISO specific terms and expressions related to conformity assessment, as well as information about ISO's adherence to the WTO principles in the Technical Barriers to Trade (TBT), see the following URL: [Foreword — Supplementary information](#).

The committee responsible for this document is ISO/TC 226, *Materials for the production of primary aluminium*.

This second edition cancels and replaces the first edition (ISO 15379-2:2004), which has been technically revised.

ISO 15379 consists of the following parts, under the general title *Carbonaceous materials for the production of aluminium — Cathode block materials*:

- *Part 1: Determination of the expansion due to sodium penetration with application of pressure*
- *Part 2: Determination of the expansion due to sodium penetration without application of pressure*

Introduction

Expansion due to sodium penetration is an important property of carbon cathode blocks. As soon as alumina electrolysis starts, sodium penetrates into the carbon cathode blocks causing swelling of these blocks. This increase in volume creates mechanical stresses within the blocks and/or bulging of the bottom block plate. This can lead to cracks through which liquid aluminium and/or liquid electrolyte can flow, reaching the thermal insulation beneath the blocks and destroying these ceramic materials. In such a case, the electrolysis cell has to be relined, resulting in loss of aluminium production and high expenses. Therefore, cathode blocks produced with materials allowing only low sodium penetration and having the lowest possible expansion due to sodium penetration are preferred.

The study can be supplemented by measuring electrical resistivity (see ISO 11713) before and after the test.

Carbonaceous materials for the production of aluminium — Cathode block materials —

Part 2:

Determination of the expansion due to sodium penetration without application of pressure

1 Scope

This part of ISO 15379 specifies a method that covers the determination of linear expansion under external pressure due to sodium penetration in cathode-block materials used in the production of aluminium.

The linear expansion of the blocks depends on the sampling direction due to anisotropy.

2 Normative references

The following documents, in whole or in part, are normatively referenced in this document and are indispensable for its application. For dated references, only the edition cited applies. For undated references, the latest edition of the referenced document (including any amendments) applies.

ISO 5725-2, *Accuracy (trueness and precision) of measurement methods and results — Part 2: Basic method for the determination of repeatability and reproducibility of a standard measurement method*

ISO 8007-1, *Carbonaceous materials used in the production of aluminium — Sampling plans and sampling from individual units — Part 1: Cathode blocks*

ASTM E 220, *Standard Test Method for Calibration of Thermocouples By Comparison Techniques*

3 Principle

An anodic graphite crucible containing a cryolitic bath with an initial cryolite ratio of 4,0 and with a cathode carbon sample suspended in the bath, as shown in [Figure 1](#), is used for this experiment. The whole assembly is heated to (980 ± 5) °C and is then electrolyzed for 2 h with a current density of approximately 0,7 A/cm² (see [Clause 7](#)). The expansion is measured by a probe, which is inserted into a hole that is drilled into the sample.

4 Apparatus

The principle of the apparatus for measuring sodium expansion is shown in [Figure 1](#).

4.1 Furnace, capable of maintaining a temperature of 980 °C, with a temperature gradient over the melt of less than 10 °C.

4.2 Furnace control device, suitable for holding the temperature at (980 ± 5) °C.

4.3 Temperature-measuring device, i.e. a thermocouple, preferably type K or S, capable of determining the temperature to ± 5 °C at 980 °C.

The thermocouple should be calibrated in accordance with ASTM E 220.

4.4 Crucible, made of graphite, with an inner diameter of 90 mm.

The crucible acts as an anode.

4.5 Copper pipe, with an outer diameter of 14 mm and an inner diameter of 12 mm.

The pipe acts as a sample holder and as a fixed reference for the expansion measurements. It also conducts current from the power supply to the sample. The pipe shall be threaded at one end and shall be long enough to extend out of the furnace when the sample is placed on the bottom of the crucible.

4.6 Inconel¹⁾ rod, with a diameter of 5 mm, which is used to measure the expansion of the sample.

The rod shall be placed inside the hole in the sample and shall reach out of the copper pipe.

4.7 Extensometer, connected to a computer or data recorder, with a measuring range of 10 mm and an accuracy of 1 μm over the whole range, to observe the expansion due to sodium penetration.

4.8 Crucible holder or supporter, made of heat-resistant steel to conduct current from the power supply to the crucible.

4.9 Graphite powder, may be used to improve the electrical connection between the crucible and the crucible holder.

4.10 Power supply, capable of supplying (54 ± 1) A DC, with a current density of the cathode that shall be approximately 0,7 A/cm².

5 Reagents

5.1 Argon, welding-grade quality.

5.2 Cryolite, Na₃AlF₆, natural, 99,7 % by mass or synthetic, >97 % by mass.

5.3 Sodium fluoride, NaF, purum, >99 % by mass.

5.4 Calcium fluoride, CaF₂, precipitated pure, >97 % by mass.

5.5 Alumina, Al₂O₃, extra pure, >98 % by mass.

5.6 Bath composition, which shall have a cryolite ratio of 4,0 and consist of the following: 71,5 % Na₃AlF₆, 14,5 % NaF, 5,0 % CaF₂, 9,0 % Al₂O₃. The bath is crushed to <2 mm using a jaw crusher and shall have a mass of 765 g.

6 Sampling

Sample the material in accordance with ISO 8007-1. The diameter of the sample shall be $(30,0 \pm 0,1)$ mm. The length shall be 100 mm. Drill a hole (6 mm \varnothing) centrally in the sample to a depth 10 mm above the bottom. The centred hole shall be threaded to a depth of (25 ± 5) mm, i.e. the distance between the measuring points shall be (65 ± 5) mm. The threaded hole shall have a diameter fitting the copper pipe.

1) Inconel is an example of a suitable product available commercially. This information is given for the convenience of users of this part of ISO 15379 and does not constitute an endorsement by ISO of this product.

7 Procedure

Mount the sample on the copper pipe (4.5). Determine the difference in position, l_0 , between the bottom end of the copper pipe and the bottom of the hole in the sample at room temperature. Prepare the bath in accordance with the conditions given in 5.6. Place the cryolitic bath components in the crucible (4.4). Place the crucible in the crucible holder (4.8). Graphite powder (4.9) can be used to improve the electrical connection between the crucible and the crucible holder. Place the crucible and the holder in the furnace (4.1). Place the sample, which is attached to the copper pipe, above the bath allowing the sample to preheat together with the crucible. Insert the Inconel rod (4.6) through the copper pipe down to the bottom of the hole in the sample.

Place the thermocouple (4.3) close to the crucible near the centre of the melt height.

Heat the furnace to (980 ± 5) °C with an argon (5.1) flush. After reaching a stable temperature, insert the sample until the bottom end of the sample is 30 mm above the bottom of the crucible.

Place the extensometer holder on top of the copper pipe. The extensometer (4.7) shall rest on top of the Inconel rod (4.6). Detect the change in position between the copper pipe and the Inconel rod. Leave the sample to be heated by the bath until no further thermally induced movement can be detected in the sample and apparatus. Measure the difference in position between the copper pipe and the Inconel rod and take this reading as the zero reference for subsequent measurements of the change in length, $\Delta l_{\text{meas}}(t)$.

Connect the power supply (4.10) to the crucible holder and the copper pipe. Electrolyze the system for 2 h with a constant current of (54 ± 1) A. Record the change in length, $\Delta l_{\text{meas}}(t)$, every minute. Then turn off the electrolysis.

Remove the sample from the bath. Allow the furnace to cool down to room temperature.

8 Results

8.1 Calculation

Calculate the relative expansion of the sample for each recording using Formula (1):

$$\Delta L(t) = \frac{\Delta l_{\text{meas}}(t)}{l_0} \times 100 \quad (1)$$

where

$\Delta L(t)$ is the relative expansion, in percent, at time, t ;

$\Delta l_{\text{meas}}(t)$ is the measured change in length, in millimetres, at time, t ;

l_0 is the difference in position, in millimetres, between the bottom end of the copper pipe and the bottom end of the Inconel rod¹⁾ at room temperature.

Plot the relative expansion, $\Delta L(t)$, versus time. Determine the maximum relative expansion, ΔL_{max} . Round the results to the second decimal place.

8.2 Precision

The precision is calculated in accordance with ISO 5725-2.

The repeatability is calculated from Formula (2):

$$r = 0,22 \times \Delta \bar{L}_{\max} + 0,03 \quad (2)$$

where

$\Delta \bar{L}_{\max}$ is the maximum average expansion;

0,03 is in absolute %.

EXAMPLE Material A has a maximum average expansion equal to 0,70 %. The repeatability is then $0,22 \times 0,70 + 0,03 = 0,18$, in % absolute.

The reproducibility is calculated from Formula (3):

$$R = 0,28 \times \Delta \bar{L}_{\max} \quad (3)$$

where the parameters are the same as for Formula (2).

The degrees of freedom, i.e. number of laboratories (e.g. 4) times the number of samples (e.g. 3), is equal to 12.

9 Test report

The report shall include the following information:

- a) reference to this part of this International Standard (e.g. ISO 15379-2:2004);
- b) all details necessary for identification of the sample;
- c) direction of the sample relative to the extrusion or vibration direction;
- d) results of the test, including the maximum expansion, ΔL_{\max} , in percent, due to sodium penetration and a plot of the relative expansion, $\Delta L(t)$, due to sodium penetration versus time, t ;
- e) date of the test;
- f) details of any unusual features noted during the determination;
- g) details of any operation not included in this part of ISO 15379 or regarded as optional.

Dimensions in millimetres

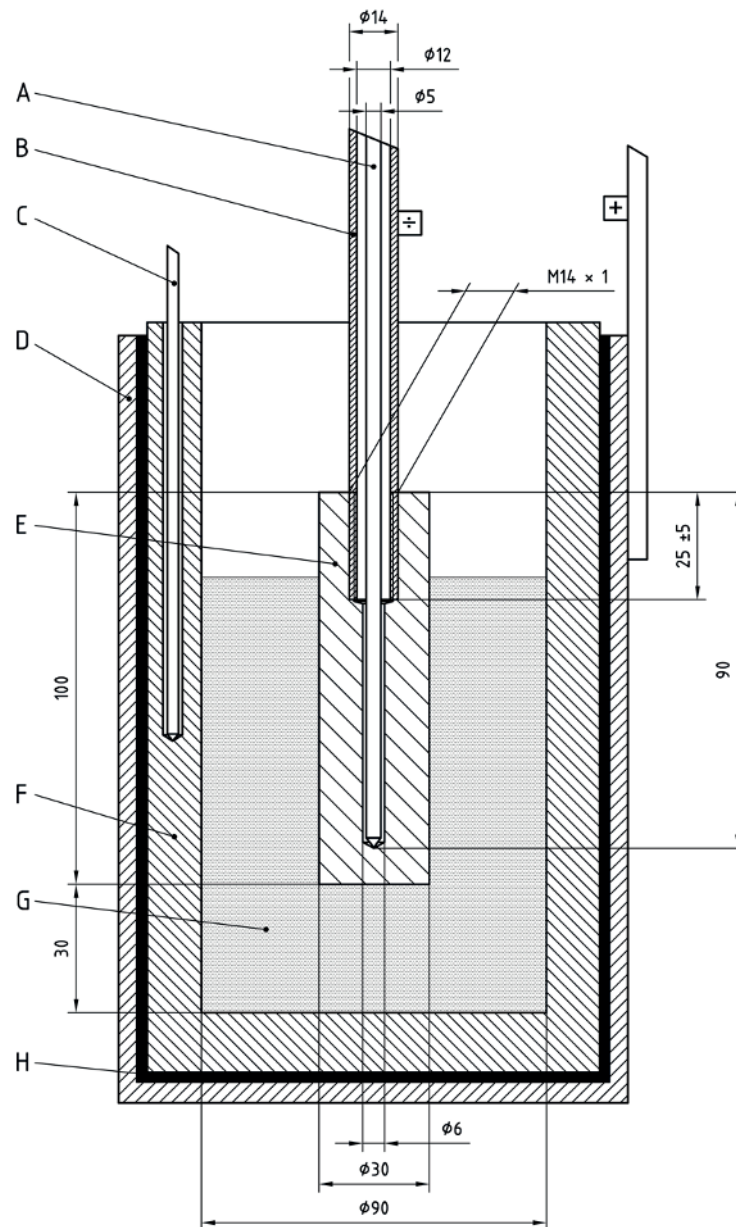

Key

- A Inconel¹⁾ rod
- B sample holder (copper)
- C thermocouple (type K or S)
- D steel container
- E sample
- F graphite crucible
- G cryolite melt
- H graphite powder

Figure 1 — Apparatus for measuring expansion due to sodium penetration

British Standards Institution (BSI)

BSI is the national body responsible for preparing British Standards and other standards-related publications, information and services.

BSI is incorporated by Royal Charter. British Standards and other standardization products are published by BSI Standards Limited.

About us

We bring together business, industry, government, consumers, innovators and others to shape their combined experience and expertise into standards-based solutions.

The knowledge embodied in our standards has been carefully assembled in a dependable format and refined through our open consultation process. Organizations of all sizes and across all sectors choose standards to help them achieve their goals.

Information on standards

We can provide you with the knowledge that your organization needs to succeed. Find out more about British Standards by visiting our website at bsigroup.com/standards or contacting our Customer Services team or Knowledge Centre.

Buying standards

You can buy and download PDF versions of BSI publications, including British and adopted European and international standards, through our website at bsigroup.com/shop, where hard copies can also be purchased.

If you need international and foreign standards from other Standards Development Organizations, hard copies can be ordered from our Customer Services team.

Subscriptions

Our range of subscription services are designed to make using standards easier for you. For further information on our subscription products go to bsigroup.com/subscriptions.

With **British Standards Online (BSOL)** you'll have instant access to over 55,000 British and adopted European and international standards from your desktop. It's available 24/7 and is refreshed daily so you'll always be up to date.

You can keep in touch with standards developments and receive substantial discounts on the purchase price of standards, both in single copy and subscription format, by becoming a **BSI Subscribing Member**.

PLUS is an updating service exclusive to BSI Subscribing Members. You will automatically receive the latest hard copy of your standards when they're revised or replaced.

To find out more about becoming a BSI Subscribing Member and the benefits of membership, please visit bsigroup.com/shop.

With a **Multi-User Network Licence (MUNL)** you are able to host standards publications on your intranet. Licences can cover as few or as many users as you wish. With updates supplied as soon as they're available, you can be sure your documentation is current. For further information, email bsmusales@bsigroup.com.

BSI Group Headquarters

389 Chiswick High Road London W4 4AL UK

Revisions

Our British Standards and other publications are updated by amendment or revision.

We continually improve the quality of our products and services to benefit your business. If you find an inaccuracy or ambiguity within a British Standard or other BSI publication please inform the Knowledge Centre.

Copyright

All the data, software and documentation set out in all British Standards and other BSI publications are the property of and copyrighted by BSI, or some person or entity that owns copyright in the information used (such as the international standardization bodies) and has formally licensed such information to BSI for commercial publication and use. Except as permitted under the Copyright, Designs and Patents Act 1988 no extract may be reproduced, stored in a retrieval system or transmitted in any form or by any means – electronic, photocopying, recording or otherwise – without prior written permission from BSI. Details and advice can be obtained from the Copyright & Licensing Department.

Useful Contacts:

Customer Services

Tel: +44 845 086 9001

Email (orders): orders@bsigroup.com

Email (enquiries): cservices@bsigroup.com

Subscriptions

Tel: +44 845 086 9001

Email: subscriptions@bsigroup.com

Knowledge Centre

Tel: +44 20 8996 7004

Email: knowledgecentre@bsigroup.com

Copyright & Licensing

Tel: +44 20 8996 7070

Email: copyright@bsigroup.com



...making excellence a habit.™