



BSI Standards Publication

# Carbonaceous materials for the production of aluminium — Cathode block materials

Part 1: Determination of the expansion due to sodium penetration with application of pressure

**National foreword**

This British Standard is the UK implementation of ISO 15379-1:2015. It supersedes BS ISO 15379-1:2004 which is withdrawn.

The UK participation in its preparation was entrusted to Technical Committee CII/24, Raw materials for the aluminium industry.

A list of organizations represented on this committee can be obtained on request to its secretary.

This publication does not purport to include all the necessary provisions of a contract. Users are responsible for its correct application.

© The British Standards Institution 2015. Published by BSI Standards Limited 2015

ISBN 978 0 580 87020 0

ICS 71.100.10

**Compliance with a British Standard cannot confer immunity from legal obligations.**

This British Standard was published under the authority of the Standards Policy and Strategy Committee on 31 May 2015.

**Amendments issued since publication**

Date	Text affected
------	---------------

---

---

---

**Carbonaceous materials for the  
production of aluminium — Cathode  
block materials —**

Part 1:  
**Determination of the expansion due to  
sodium penetration with application  
of pressure**

*Produits carbonés utilisés pour la production de l'aluminium — Blocs  
cathodiques —*

*Partie 1: Détermination de l'expansion due à la pénétration du  
sodium avec application de pression*





## **COPYRIGHT PROTECTED DOCUMENT**

© ISO 2015, Published in Switzerland

All rights reserved. Unless otherwise specified, no part of this publication may be reproduced or utilized otherwise in any form or by any means, electronic or mechanical, including photocopying, or posting on the internet or an intranet, without prior written permission. Permission can be requested from either ISO at the address below or ISO's member body in the country of the requester.

ISO copyright office  
Ch. de Blandonnet 8 • CP 401  
CH-1214 Vernier, Geneva, Switzerland  
Tel. +41 22 749 01 11  
Fax +41 22 749 09 47  
copyright@iso.org  
www.iso.org

# Contents

Page

<b>Foreword</b> .....	<b>iv</b>
<b>Introduction</b> .....	<b>v</b>
<b>1 Scope</b> .....	<b>1</b>
<b>2 Normative references</b> .....	<b>1</b>
<b>3 Principle</b> .....	<b>1</b>
<b>4 Apparatus</b> .....	<b>1</b>
<b>5 Reagents</b> .....	<b>2</b>
<b>6 Samples</b> .....	<b>3</b>
<b>7 Procedure</b> .....	<b>3</b>
<b>8 Results</b> .....	<b>4</b>
8.1 Calculation.....	4
8.2 Precision.....	4
<b>9 Test report</b> .....	<b>4</b>

## Foreword

ISO (the International Organization for Standardization) is a worldwide federation of national standards bodies (ISO member bodies). The work of preparing International Standards is normally carried out through ISO technical committees. Each member body interested in a subject for which a technical committee has been established has the right to be represented on that committee. International organizations, governmental and non-governmental, in liaison with ISO, also take part in the work. ISO collaborates closely with the International Electrotechnical Commission (IEC) on all matters of electrotechnical standardization.

The procedures used to develop this document and those intended for its further maintenance are described in the ISO/IEC Directives, Part 1. In particular the different approval criteria needed for the different types of ISO documents should be noted. This document was drafted in accordance with the editorial rules of the ISO/IEC Directives, Part 2. [www.iso.org/directives](http://www.iso.org/directives)

Attention is drawn to the possibility that some of the elements of this document may be the subject of patent rights. ISO shall not be held responsible for identifying any or all such patent rights. Details of any patent rights identified during the development of the document will be in the Introduction and/or on the ISO list of patent declarations received. [www.iso.org/patents](http://www.iso.org/patents)

Any trade name used in this document is information given for the convenience of users and does not constitute an endorsement.

For an explanation on the meaning of ISO specific terms and expressions related to conformity assessment, as well as information about ISO's adherence to the WTO principles in the Technical Barriers to Trade (TBT), see the following URL: [Foreword — Supplementary information](#).

The committee responsible for this document is ISO/TC 226, *Materials for the production of primary aluminium*.

This second edition cancels and replaces the first edition (ISO 15379-1:2004), which has been technically revised.

ISO 15379 consists of the following parts, under the general title *Carbonaceous materials for the production of aluminium — Cathode block materials*:

- *Part 1: Determination of the expansion due to sodium penetration with application of pressure*
- *Part 2: Determination of the expansion due to sodium penetration without application of pressure*

## Introduction

Expansion due to sodium penetration is an important property of carbon cathode blocks. As soon as alumina electrolysis starts, sodium penetrates into the carbon cathode blocks causing swelling of these blocks. This increase in volume creates mechanical stresses within the blocks and/or bulging of the bottom block plate. This can lead to cracks through which liquid aluminium and/or liquid electrolyte can flow, reaching the thermal insulation beneath the blocks and destroying these ceramic materials. In such a case, the electrolysis cell has to be relined, resulting in loss of aluminium production and high expenses. Therefore, cathode blocks produced with materials allowing only low sodium penetration and having the lowest possible expansion due to sodium penetration are preferred.

The study can be supplemented by measuring electrical resistivity (see ISO 11713) before and after the test.

Due to thermal and sodium expansion when heating up the cathode blocks in the electrolysis cells to operational temperature, the block will be subject to pressure from the steel shell; therefore, in the present method, 5 MPa is chosen as a realistic maximum pressure.





# Carbonaceous materials for the production of aluminium — Cathode block materials —

## Part 1:

# Determination of the expansion due to sodium penetration with application of pressure

## 1 Scope

This part of ISO 15379 specifies a method that covers the determination of linear expansion under external pressure due to sodium penetration in cathode-block materials used in the production of aluminium.

The linear expansion of the blocks depends on the sampling direction due to anisotropy.

## 2 Normative references

The following documents, in whole or in part, are normatively referenced in this document and are indispensable for its application. For dated references, only the edition cited applies. For undated references, the latest edition of the referenced document (including any amendments) applies.

ISO 5725-2, *Accuracy (trueness and precision) of measurement methods and results — Part 2: Basic method for the determination of repeatability and reproducibility of a standard measurement method*

ISO 8007-1, *Carbonaceous materials used in the production of aluminium — Sampling plans and sampling from individual units — Part 1: Cathode blocks*

ASTM E 220, *Standard Test Method for Calibration of Thermocouples By Comparison Techniques*

## 3 Principle

An anodic graphite crucible containing a cryolitic bath with an initial cryolite ratio of 4,0 and with a cathode carbon sample placed in the crucible, as shown in [Figure 1](#), is used for this experiment. The whole sample is immersed in a cryolitic bath with a graphite cylinder fitted as an extension from the sample. The crucible is placed in a crucible support, which is connected to a hydraulic power cylinder. A constant pressure of 5 MPa is applied to the sample by pressing the graphite cylinder against a stop rod in the top of the furnace by the hydraulic power cylinder. The whole assembly is heated in a tubular furnace to  $(980 \pm 5) ^\circ\text{C}$  and is then electrolyzed for 2 h with a current density of approximately  $0,7 \text{ A/cm}^2$  (see [Clause 7](#) for precise setting). The expansion is measured by a probe, which is fastened to the frame of the furnace and measures the position of the crucible support.

## 4 Apparatus

The principle of the apparatus for measuring sodium expansion is shown in [Figure 1](#).

**4.1 Furnace**, capable of maintaining a temperature of  $980 ^\circ\text{C}$ , with a temperature gradient over the melt of less than  $10 ^\circ\text{C}$ .

**4.2 Furnace control device**, suitable for holding the temperature at  $(980 \pm 5) ^\circ\text{C}$ .

**4.3 Temperature-measuring device**, i.e. a thermocouple, preferably of type K or S, capable of determining the temperature to  $\pm 5$  °C at 980 °C.

The thermocouple should be calibrated in accordance with ASTM E 220.

**4.4 Crucible**, made of graphite, with an inner diameter of 90 mm and an inner height of 90 mm.

The crucible acts as an anode.

**4.5 Lid**, made of graphite, which shall have a hole in the centre to allow the sample/graphite extension to reach above the lid.

**4.6 Insulating ring**, made of a ceramic material, which resists the temperature and the fluoride environment.

The ring shall be placed in the hole of the graphite lid and act as an electrical insulation between the lid and the sample/graphite extension. The ring shall be large enough to allow the sample/graphite extension to move freely in the vertical direction.

**4.7 Crucible support**, made of heat-resistant steel to conduct anodic current from the power supply to the crucible.

**4.8 Stop rod**, made of heat-resistant steel to conduct cathodic current to the top of the sample.

The stop rod acts as a fixed reference point for the expansion measurements.

The material for the steel support and the steel stop rod should have minimal deformation at a pressure of 5 MPa.

NOTE The steel quality Sanicro 31HT<sup>1)</sup>, X 10 NiCrAlTi32.20 has been shown suitable for the crucible support rod and the stop rod. If other steel grades are used, it has to be verified that they do not deform significantly versus the length change of the sample.

**4.9 Alumina disk**, capable of covering the bottom of the crucible and capable of acting as electrical insulation between the crucible and the sample. The disk should preferably have a centring slot to help position the sample in the centre of the crucible.

**4.10 Graphite cylinder**, which shall be used as an extension to the sample and shall have a diameter of  $(30,0 \pm 0,1)$  mm and a length of  $(40 \pm 1)$  mm.

**4.11 Hydraulic power cylinder**, capable of applying a constant pressure of  $5 \text{ MPa} \pm 0,1 \text{ MPa}$  during the whole experiment independent of the expansion of the sample.

**4.12 Extensometer**, connected to a computer or data recorder, with a measuring range of 10 mm and an accuracy of 1  $\mu\text{m}$  over the whole range, in order to observe the expansion due to sodium penetration.

**4.13 Power supply**, capable of supplying 39,6 A DC, with a current density of the cathode which shall be 0,7 A/cm<sup>2</sup>.

## 5 Reagents

**5.1 Argon**, welding-grade quality.

---

1) Sanicro 31HT is an example of a suitable product available commercially. This information is given for the convenience of users of this part of ISO 15379 and does not constitute an endorsement by ISO of this product.

**5.2 Cryolite**,  $\text{Na}_3\text{AlF}_6$ , natural, > 99,7 % by mass or synthetic, >97 % by mass.

**5.3 Sodium fluoride**, NaF, purum, >99 % by mass.

**5.4 Calcium fluoride**,  $\text{CaF}_2$ , precipitated pure, >97 % by mass.

**5.5 Alumina**,  $\text{Al}_2\text{O}_3$ , extra pure, >98 % by mass.

**5.6 Bath composition**, which shall have a cryolite ratio of 4,0 and consist of the following: 71,5 %  $\text{Na}_3\text{AlF}_6$ , 14,5 % NaF, 5,0 %  $\text{CaF}_2$ , 9,0 %  $\text{Al}_2\text{O}_3$ . The bath is crushed to <2 mm using a jaw crusher and shall have a mass of 765 g.

## 6 Samples

Sample the material in accordance with ISO 8007-1. The diameter of the sample shall be  $(30,0 \pm 0,1)$  mm. The length shall be  $(60 \pm 1)$  mm.

## 7 Procedure

Assemble the crucible support (4.7) with the crucible (4.4) and the sample so they can be pressed together with a hydraulic power cylinder against a heat-resistant steel stop rod (4.8) conducting the cathodic current to the top of the sample (see Figure 1). The stop rod (4.8) acts as a fixed reference point for the expansion measurements. Place the alumina disk (4.9) in the bottom of the crucible (4.4). Measure the length,  $l_0$ , of the sample at room temperature with an accuracy of 0,1 mm. Place the sample on the alumina disk in the centre of the crucible. Place the graphite cylinder (4.10) on top of the sample. Fill the crucible with the bath prepared in accordance with 5.6. Place the lid (4.5), with an insulating ring (4.6) around the graphite extension, on top of the crucible.

Lift the crucible by the hydraulic power cylinder (4.11) until the sample touches the stop rod (4.8) inside the furnace (4.1). Adjust the hydraulic pressure to 5 MPa.

Place the thermocouple close to the crucible near the centre of the melt height.

Place the extensometer (4.12) underneath the base of the crucible holder outside the furnace.

Heat the furnace to  $(980 \pm 5)$  °C with an argon (5.1) flush, and measure the change in the length of the sample and the apparatus. Wait until no further thermally induced movement can be detected in the sample and apparatus. Determine the position of the crucible support and take this reading as the zero reference for subsequent measurements of the change in length,  $\Delta l_{\text{meas}}(t)$ .

Connect the power supply (4.13) to the crucible support and the stop rod. Electrolyze the system for 2 h with a constant current of 39,6 A. Record the change in length,  $\Delta l_{\text{meas}}(t)$ , every minute. Then, turn off the electrolysis.

Release the pressure, but keep the crucible inside the furnace. Allow the furnace to cool down to room temperature.

## 8 Results

### 8.1 Calculation

Calculate the relative expansion of the sample for each recording using Formula (1):

$$\Delta L(t) = \frac{\Delta l_{\text{meas}}(t)}{l_0} \times 100 \quad (1)$$

where

$\Delta L(t)$  is the relative expansion, in percent, at time,  $t$ ;

$\Delta l_{\text{meas}}(t)$  is the measured change in length, in millimetres, at time,  $t$ ;

$l_0$  is the initial sample length, in millimetres.

Plot the relative expansion,  $\Delta L(t)$ , versus time. Determine the maximum relative expansion,  $\Delta L_{\text{max}}$ . Round the results to the second decimal place.

### 8.2 Precision

The precision is calculated in accordance with ISO 5725-2.

The repeatability is calculated from Formula (2):

$$r = 0,20 \times \Delta \bar{L}_{\text{max}} + 0,02 \quad (2)$$

where

$\Delta \bar{L}_{\text{max}}$  is the maximum average expansion;

0,02 is in absolute %.

**EXAMPLE** Material A has a maximum average expansion equal to 0,56 %. The repeatability is then  $0,20 \times 0,56 + 0,03 = 0,15$ , in % absolute.

The reproducibility is calculated from Formula (3):

$$R = 0,24 \times \Delta \bar{L}_{\text{max}} + 0,03 \quad (3)$$

where the parameters are the same as for Formula (2).

The degrees of freedom, i.e. number of laboratories (e.g. 4) times the number of samples (e.g. 3), is equal to 12.

## 9 Test report

The report shall include the following information:

- a) reference to this part of this International Standard (e.g. ISO 15379-1:2015);
- b) all details necessary for identification of the sample;
- c) direction of the sample relative to the extrusion or vibration direction;
- d) results of the test, including the maximum expansion,  $\Delta L_{\text{max}}$ , in percent, due to sodium penetration and a plot of the relative expansion,  $\Delta L(t)$ , due to sodium penetration versus time,  $t$ ;

- e) date of the test;
- f) details of any unusual features noted during the determination;
- g) details of any operation not included in this part of ISO 15379 or regarded as optional.

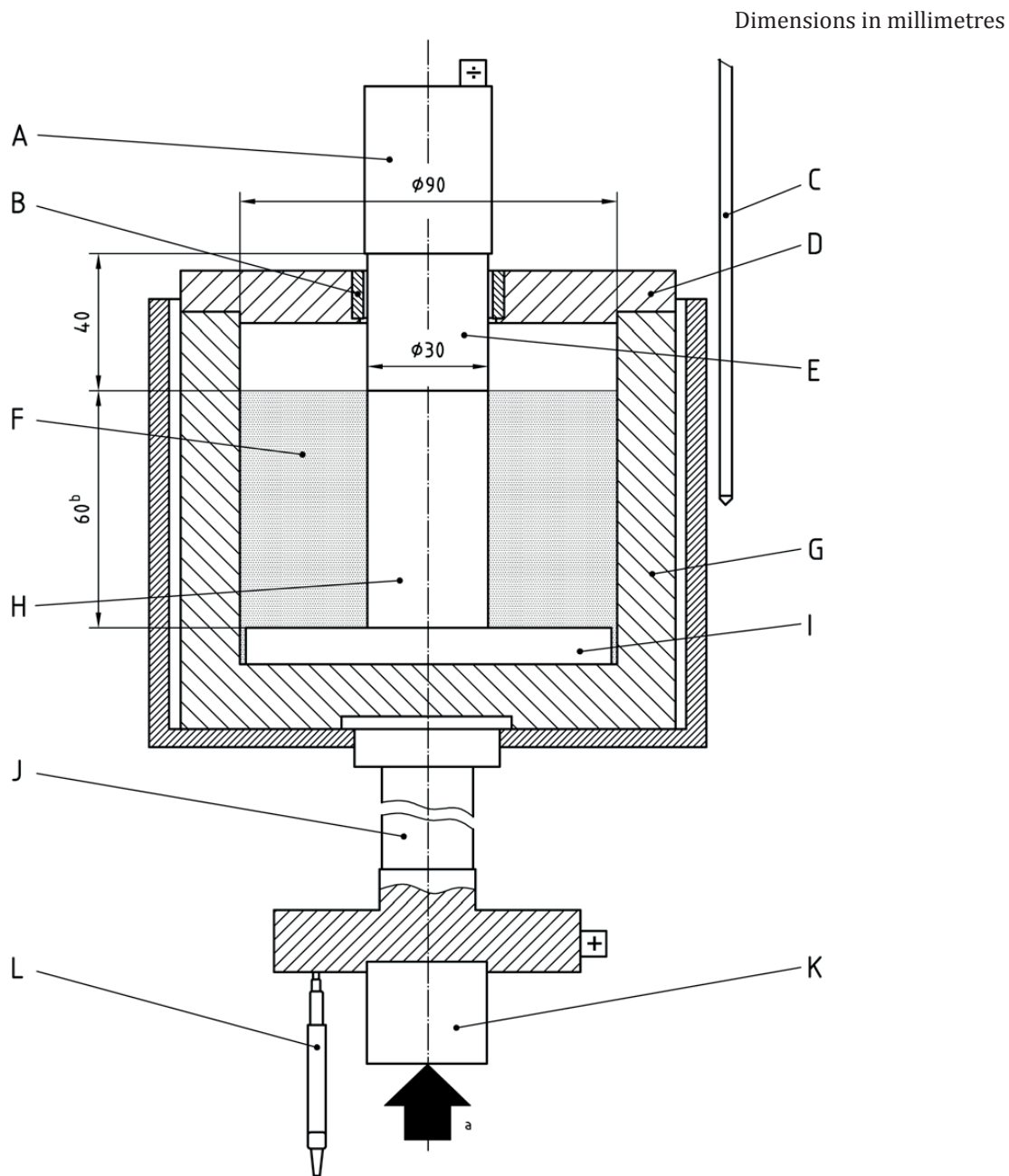

**Key**

- |   |                                      |   |                                       |
|---|--------------------------------------|---|---------------------------------------|
| A | heat-resistant steel stop rod        | G | graphite crucible                     |
| B | insulating ring                      | H | sample                                |
| C | thermocouple (type K or S)           | I | alumina disk                          |
| D | graphite lid                         | J | heat resistant steel crucible support |
| E | graphite cylinder (sample extension) | K | hydraulic power cylinder              |
| F | cryolite melt                        | L | extensometer                          |
| a | Pressure.                            |   |                                       |
| b | Initial sample length (= $l_0$ ).    |   |                                       |

**Figure 1 — Apparatus for measuring expansion due to sodium penetration**









# British Standards Institution (BSI)

BSI is the national body responsible for preparing British Standards and other standards-related publications, information and services.

BSI is incorporated by Royal Charter. British Standards and other standardization products are published by BSI Standards Limited.

## About us

We bring together business, industry, government, consumers, innovators and others to shape their combined experience and expertise into standards-based solutions.

The knowledge embodied in our standards has been carefully assembled in a dependable format and refined through our open consultation process. Organizations of all sizes and across all sectors choose standards to help them achieve their goals.

## Information on standards

We can provide you with the knowledge that your organization needs to succeed. Find out more about British Standards by visiting our website at [bsigroup.com/standards](http://bsigroup.com/standards) or contacting our Customer Services team or Knowledge Centre.

## Buying standards

You can buy and download PDF versions of BSI publications, including British and adopted European and international standards, through our website at [bsigroup.com/shop](http://bsigroup.com/shop), where hard copies can also be purchased.

If you need international and foreign standards from other Standards Development Organizations, hard copies can be ordered from our Customer Services team.

## Subscriptions

Our range of subscription services are designed to make using standards easier for you. For further information on our subscription products go to [bsigroup.com/subscriptions](http://bsigroup.com/subscriptions).

With **British Standards Online (BSOL)** you'll have instant access to over 55,000 British and adopted European and international standards from your desktop. It's available 24/7 and is refreshed daily so you'll always be up to date.

You can keep in touch with standards developments and receive substantial discounts on the purchase price of standards, both in single copy and subscription format, by becoming a **BSI Subscribing Member**.

**PLUS** is an updating service exclusive to BSI Subscribing Members. You will automatically receive the latest hard copy of your standards when they're revised or replaced.

To find out more about becoming a BSI Subscribing Member and the benefits of membership, please visit [bsigroup.com/shop](http://bsigroup.com/shop).

With a **Multi-User Network Licence (MUNL)** you are able to host standards publications on your intranet. Licences can cover as few or as many users as you wish. With updates supplied as soon as they're available, you can be sure your documentation is current. For further information, email [bsmusales@bsigroup.com](mailto:bsmusales@bsigroup.com).

## BSI Group Headquarters

389 Chiswick High Road London W4 4AL UK

## Revisions

Our British Standards and other publications are updated by amendment or revision.

We continually improve the quality of our products and services to benefit your business. If you find an inaccuracy or ambiguity within a British Standard or other BSI publication please inform the Knowledge Centre.

## Copyright

All the data, software and documentation set out in all British Standards and other BSI publications are the property of and copyrighted by BSI, or some person or entity that owns copyright in the information used (such as the international standardization bodies) and has formally licensed such information to BSI for commercial publication and use. Except as permitted under the Copyright, Designs and Patents Act 1988 no extract may be reproduced, stored in a retrieval system or transmitted in any form or by any means – electronic, photocopying, recording or otherwise – without prior written permission from BSI. Details and advice can be obtained from the Copyright & Licensing Department.

## Useful Contacts:

### Customer Services

**Tel:** +44 845 086 9001

**Email (orders):** [orders@bsigroup.com](mailto:orders@bsigroup.com)

**Email (enquiries):** [cservices@bsigroup.com](mailto:cservices@bsigroup.com)

### Subscriptions

**Tel:** +44 845 086 9001

**Email:** [subscriptions@bsigroup.com](mailto:subscriptions@bsigroup.com)

### Knowledge Centre

**Tel:** +44 20 8996 7004

**Email:** [knowledgecentre@bsigroup.com](mailto:knowledgecentre@bsigroup.com)

### Copyright & Licensing

**Tel:** +44 20 8996 7070

**Email:** [copyright@bsigroup.com](mailto:copyright@bsigroup.com)



...making excellence a habit.™