

BS ISO 15371:2015



BSI Standards Publication

# **Ships and marine technology — Fire-extinguishing systems for protection of galley cooking equipment**

**bsi.**

...making excellence a habit.™

**National foreword**

This British Standard is the UK implementation of ISO 15371:2015. It supersedes BS ISO 15371:2009 which is withdrawn.

The UK participation in its preparation was entrusted to Technical Committee SME/32, Ships and marine technology - Steering committee.

A list of organizations represented on this committee can be obtained on request to its secretary.

This publication does not purport to include all the necessary provisions of a contract. Users are responsible for its correct application.

© The British Standards Institution 2015.  
Published by BSI Standards Limited 2015

ISBN 978 0 580 89822 8

ICS 13.220.10; 47.020.99

**Compliance with a British Standard cannot confer immunity from legal obligations.**

This British Standard was published under the authority of the Standards Policy and Strategy Committee on 31 December 2015.

**Amendments/corrigenda issued since publication**

Date	Text affected
------	---------------

---

INTERNATIONAL  
STANDARD

BS ISO 15371:2015

**ISO**  
**15371**

Third edition  
2015-11-15

---

---

**Ships and marine technology — Fire-  
extinguishing systems for protection  
of galley cooking equipment**

*Navires et technologie maritime — Systèmes d'extinction d'incendie  
des équipements de cuisine*



Reference number  
ISO 15371:2015(E)

© ISO 2015



**COPYRIGHT PROTECTED DOCUMENT**

© ISO 2015, Published in Switzerland

All rights reserved. Unless otherwise specified, no part of this publication may be reproduced or utilized otherwise in any form or by any means, electronic or mechanical, including photocopying, or posting on the internet or an intranet, without prior written permission. Permission can be requested from either ISO at the address below or ISO's member body in the country of the requester.

ISO copyright office  
Ch. de Blandonnet 8 • CP 401  
CH-1214 Vernier, Geneva, Switzerland  
Tel. +41 22 749 01 11  
Fax +41 22 749 09 47  
copyright@iso.org  
www.iso.org

# Contents

Page

<b>Foreword</b> .....	<b>v</b>
<b>Introduction</b> .....	<b>vi</b>
<b>1 Scope</b> .....	<b>1</b>
<b>2 Terms and definitions</b> .....	<b>1</b>
<b>3 Components</b> .....	<b>4</b>
3.1 General.....	4
3.2 Detectors.....	4
3.3 Discharge nozzles.....	5
3.4 Operating devices.....	5
3.5 Manual actuators.....	5
3.6 Shut-off devices.....	5
3.7 Pipe, fittings, tubing and hose.....	6
3.8 Extinguishing agent.....	6
3.9 Indicators.....	6
<b>4 System requirements</b> .....	<b>6</b>
4.1 General.....	6
4.2 Use.....	6
4.3 Applications.....	6
4.4 System actuation.....	7
4.5 Supervision.....	8
4.6 System location.....	8
4.7 Discharge nozzles.....	8
4.8 Special requirements.....	8
4.9 Protection of common exhaust duct.....	9
<b>5 Test methods</b> .....	<b>9</b>
5.1 Cooking appliance extinguishing tests.....	9
5.1.1 General.....	9
5.1.2 Deep fat fryer.....	10
5.1.3 Griddle.....	11
5.1.4 Range top.....	12
5.1.5 Gas radiant char-broiler.....	12
5.1.6 Electric char-broiler.....	13
5.1.7 Lava, pumice or synthetic rock char-broiler.....	13
5.1.8 Natural charcoal broiler.....	13
5.1.9 Mesquite wood char-broiler.....	14
5.1.10 Upright broiler.....	14
5.1.11 Chain broiler.....	14
5.1.12 Wok.....	15
5.2 Splash tests.....	15
5.2.1 Deep fat fryer extinguishing splash tests.....	15
5.2.2 Deep fat fryer cooking temperature splash test.....	16
5.2.3 Range top extinguishing splash tests.....	17
5.2.4 Range top cooking temperature splash tests.....	17
5.2.5 Wok extinguishing splash test.....	18
5.2.6 Wok cooking temperature splash tests.....	18
5.3 Hood and duct (full scale) extinguishing test.....	19
5.3.1 General.....	19
5.3.2 Hood.....	19
5.3.3 Filter and frame.....	19
5.3.4 Duct.....	20
5.4 Extinguishing system unit test.....	21
5.4.1 Preparation.....	21

5.4.2	General test procedures.....	22
5.4.3	Fuel ignition and extinguishing system unit operation.....	23
5.4.4	Plenum testing.....	23
5.4.5	Conditions of acceptability.....	23
<b>6</b>	<b>Installation, operation and maintenance instruction manual.....</b>	<b>23</b>
<b>7</b>	<b>Owner's manual.....</b>	<b>25</b>
<b>8</b>	<b>Test report.....</b>	<b>26</b>

## Foreword

ISO (the International Organization for Standardization) is a worldwide federation of national standards bodies (ISO member bodies). The work of preparing International Standards is normally carried out through ISO technical committees. Each member body interested in a subject for which a technical committee has been established has the right to be represented on that committee. International organizations, governmental and non-governmental, in liaison with ISO, also take part in the work. ISO collaborates closely with the International Electrotechnical Commission (IEC) on all matters of electrotechnical standardization.

The procedures used to develop this document and those intended for its further maintenance are described in the ISO/IEC Directives, Part 1. In particular the different approval criteria needed for the different types of ISO documents should be noted. This document was drafted in accordance with the editorial rules of the ISO/IEC Directives, Part 2. [www.iso.org/directives](http://www.iso.org/directives)

Attention is drawn to the possibility that some of the elements of this document may be the subject of patent rights. ISO shall not be held responsible for identifying any or all such patent rights. Details of any patent rights identified during the development of the document will be in the Introduction and/or on the ISO list of patent declarations received. [www.iso.org/patents](http://www.iso.org/patents)

Any trade name used in this document is information given for the convenience of users and does not constitute an endorsement.

For an explanation on the meaning of ISO specific terms and expressions related to conformity assessment, as well as information about ISO's adherence to the WTO principles in the Technical Barriers to Trade (TBT), see the following URL: [Foreword - Supplementary information](#)

The committee responsible for this document is ISO/TC 8, *Ships and marine technology*, Subcommittee SC 1, *Lifesaving and fire protection*.

This third edition cancels and replaces the second edition (ISO 15371:2015). [Subclauses 2.25](#), [2.26](#), [4.4.13](#), and [5.1.1.2 b\)](#) have been editorially revised to clarify requirements.

## Introduction

While this International Standard provides the marine industry with a means for evaluating the effectiveness of fire-extinguishing systems for a variety of grease-laden cooking appliances that may be found in a galley, it is also referenced by the International Maritime Organization (IMO) International Convention for the Safety of Life at Sea (SOLAS), 1974, as amended, and provides organizations who are party to SOLAS with a means of ensuring conformance of deep-fat cooking equipment with the fire suppression requirements prescribed in SOLAS.



# Ships and marine technology — Fire-extinguishing systems for protection of galley cooking equipment

## 1 Scope

This International Standard applies to the design, testing, and operation of pre-engineered fire extinguishing systems to protect the galley hoods, ducts, fryers and other grease-laden appliances.

Pre-engineered fire-extinguishing system units are also required to comply with requirements for the construction and components performance as applicable to specific types, designs, sizes and arrangements. This International Standard also provides minimum requirements for the testing and evaluation of components.

A product that contains features, characteristics, components, materials or systems that are new or different from those covered by the requirements in this International Standard and that involve a risk of fire, electric shock, or injury to persons, shall be evaluated using the appropriate additional component and end product testing.

**NOTE** Only deep-fat cooking equipment, among the types of galley cooking equipment covered by this International Standard, are required by SOLAS chapter II-2 Regulation 10.6.4 to have fixed fire-extinguishing systems.

## 2 Terms and definitions

For the purposes of this document, the following terms and definitions apply.

### 2.1

#### **auxiliary equipment**

equipment used in conjunction with the extinguishing system

**EXAMPLE** Auxiliary equipment can be used to shut down power, fuel or ventilation to the hazard area being protected or to initiate alarm or signalling devices.

### 2.2

#### **cooking appliance**

cooking device that has, or is capable of having, a surface of liquid grease or one in which cooking with grease is involved

**EXAMPLE** Deep fat fryer, griddle, range, chain-broiler, electric char-broiler, charcoal broiler, mesquite broiler, gas radiant char broiler, wok, tilt skillet/braising pan and similar appliances.

Note 1 to entry: The protected area is limited to the cooking area of the appliance only.

### 2.3

#### **cooking grease**

##### **grease**

vegetable shortening incorporating an antifoaming agent

### 2.4

#### **cylinder**

##### **valve assembly**

container that incorporates a valve and that provides storage for the extinguishing agent and expellant gas until the valve is actuated

Note 1 to entry: For cartridge-operated units, this assembly includes the extinguishing-agent storage container and cartridge mechanism.

**2.5**

**deep fat fryer**

commercially available electric cooking appliance in which cooking greases in depth are used

**2.6**

**discharge nozzle**

device that is used to distribute the extinguishing agent over or into a specific area

**2.7**

**discharge rate**

ratio of the quantity of the extinguishing agent discharged from a nozzle to the discharge time measured to within  $\pm 1$  s, expressed in kg/s

**2.8**

**discharge time**

time interval between the first appearance of the extinguishing agent at the nozzle and the time at which the discharge becomes predominantly gaseous or ceases

**2.9**

**duct**

**duct system**

continuous enclosed passageway for the transmission of air and cooking vapours

**2.10**

**expellent gas**

nitrogen air or other gas used to facilitate the discharge of the extinguishing agent

**2.11**

**extinguishing system unit**

identified components that can be assembled into a system for the discharge of an extinguishing agent through fixed piping and nozzles for the purpose of extinguishing fires

**2.12**

**gas cartridge**

container that provides storage for an expellant gas only

**2.13**

**grease filter**

component of a grease vapour removal system that deflects the air and vapours passing through it in such a manner as to result in the grease vapours concentrating, condensing, or both, for the purpose of grease collection

**2.14**

**hood**

device provided as part of an exhaust system to direct and capture grease vapours and exhaust gases from a cooking appliance

**2.15**

**indicator**

mechanical or electrical device that shows when an extinguishing system or one of its critical components is ready to operate or has already operated

**2.16**

**inspection**

visual examination of the system or portion thereof to verify that it appears to be in operating condition and is free of physical damage

**2.17**

**low quality fatty beef steak**

beef steak containing 20 % to 30 % fat or gristle, well marbled and uniform in size

**2.18**

**maintenance**

work, including, but not limited to, repair, replacement and service, performed to ensure that the equipment operates properly

**2.19**

**manual means of actuation**

means of system actuation in which a system is discharged by manual means

**2.20**

**manufacturer's installation and maintenance manual**

document containing the design, installation and maintenance instructions which is prepared and approved as a complimentary part of the extinguishing system

**2.21**

**multiple-vat deep fat fryer**

multiple electric fryers that are mechanically joined together

Note 1 to entry: Each vat incorporates a separately controlled heating source.

**2.22**

**operable pressure**

pressure developed in a fully charged container conditioned at 21 °C for at least 24 h

**2.23**

**operable pressure range**

pressure range corresponding to the pressures in the storage container at the specified minimum and maximum temperatures for which the extinguishing system is intended to be operable

**2.24**

**operating devices**

mechanical, electrical or pneumatic devices involved in the operation of a system

**2.25**

**operation**

(automatic) operation without human intervention

Note 1 to entry: Methods of automatic operation include, but are not limited to, heat, rate of temperature rise, smoke or pressure change.

**2.26**

**operation**

(manual) operation of a system or its components through human action

**2.27**

**owner's manual**

pamphlet containing the manufacturer's recommendations for proper inspection and operation, which is prepared and approved as a complimentary part of the extinguishing system

**2.28**

**plenum**

volume of enclosed space between the grease filters and the portion of the hood above the grease filters in a hood and duct system

## 2.29

### **pre-engineered system**

system that is tested in accordance with the limitations prescribed by the manufacturer for the maximum and minimum pipe lengths, accessories, number of fittings, number and types of nozzles, nozzle placement, types of fire risk and the maximum dimensions, volumes and areas of the appliances, hoods and ducts to be protected

Note 1 to entry: The hazards protected by these systems are specifically limited as to type and size by testing on actual fires.

Note 2 to entry: The limitations on hazards that are permitted to be protected by these systems and piping and nozzle configurations are those contained in the manufacturer's installation and maintenance manual.

## 2.30

### **pressure vessel**

#### **pressure cylinder**

container that provides storage for the extinguishing agent and expellant gas

## 2.31

### **product**

fire extinguishing system or any part thereof covered by the requirements of this International Standard

## 2.32

### **shut-off device**

device that operates simultaneously with the extinguishing system to shut off fuel and power to the appliances protected by the system and other appliances required to be shut off upon operation of the system

## 2.33

### **signal**

status indication communicated by electrical or other means

## 2.34

### **split-vat deep fat fryer**

electric fryer that incorporates a divided partition which splits the fryer in sections

Note 1 to entry: Each split-vat fryer incorporates a separately controlled heating source.

## 2.35

### **tilt skillets**

cooking devices which are intended to braise, simmer, sauté, or fry foods

## 2.36

### **braising pans**

cooking devices which are intended to braise, simmer, sauté, or fry foods

## 3 Components

### 3.1 General

Only system components referenced or permitted in the manufacturer's installation and maintenance manual or alternative components that have been approved for use with the specific extinguishing system shall be used.

### 3.2 Detectors

Detectors shall be approved devices that are capable of detecting fire.

### **3.3 Discharge nozzles**

**3.3.1** Discharge nozzles shall be approved for their intended use.

**3.3.2** Nozzles shall be provided with an internal strainer or a separate approved strainer located immediately up-stream of the nozzle.

**3.3.3** Nozzles shall be constructed of brass, stainless-steel, or other corrosion-resistant materials, or be protected inside and out against corrosion.

**3.3.4** Nozzles shall be made of non-combustible materials and shall withstand the expected fire exposure without deformation.

**3.3.5** Nozzles shall be permanently marked for identification.

**3.3.6** All discharge nozzles shall be provided with caps or other suitable devices to prevent the entrance of grease vapours, moisture, or other foreign materials into the piping.

**3.3.7** The caps or other protection devices shall blow off, open or blow out upon agent discharge.

### **3.4 Operating devices**

**3.4.1** Operating devices shall be designed for the service they will encounter and shall not be rendered inoperative by, or be susceptible to, accidental operation.

**3.4.2** Operating devices shall be designed to function properly through a temperature range from 0 °C to 49 °C, or marked to indicate the temperature limitations.

### **3.5 Manual actuators**

**3.5.1** Manual actuators shall not require a force of more than 178 N.

**3.5.2** Manual actuators shall not require a movement of more than 356 mm to secure operation.

**3.5.3** All manual actuators shall be provided with operating instructions. These instructions may include the use of pictographs, and shall have lettering at least 6 mm in height.

**3.5.4** All remote manual operating devices shall be marked to identify the hazard against which they protect.

### **3.6 Shut-off devices**

**3.6.1** On activation of any cooking equipment or hood/duct fire extinguishing system, all sources of fuel and electric power that produce heat to all equipment protected by the system shall be shut off automatically.

**3.6.2** Gas appliances not requiring protection but located under the same ventilation equipment shall also be shut off.

**3.6.3** Exhaust fans and dampers are not required to be shut off on system actuation if the fire-extinguishing system has been tested under both zero and high-velocity flow conditions.

**3.6.4** If the expellant gas is used to pneumatically operate the shut-off devices, the gas shall be sourced prior to its entry into the agent storage cylinder.

**3.6.5** Shut-off devices shall require manual resetting prior to fuel or power being restored.

### **3.7 Pipe, fittings, tubing and hose**

**3.7.1** Pipe and associated fittings shall be of non-combustible material having physical and chemical characteristics compatible with the extinguishing agent.

**3.7.2** The pressure rating of the pipe, fittings and connection joints shall withstand the maximum expected pressure in the piping system.

**3.7.3** Pipe, tubing, hose and fitting materials and types shall be in accordance with the manufacturer's installation and maintenance manual.

### **3.8 Extinguishing agent**

**3.8.1** The agent used shall be identified for the particular system in the operation and maintenance manual as recommended by the manufacturer of the system.

**3.8.2** Agents from different manufacturers shall not be mixed.

### **3.9 Indicators**

**3.9.1** Systems shall be provided with an audible or visual indicator to show that the system is in a ready condition or is in need of recharging.

## **4 System requirements**

### **4.1 General**

**4.1.1** Fire-extinguishing systems shall meet the requirements of [5.4](#).

### **4.2 Use**

**4.2.1** Equipment that can be protected against hazard includes:

- a) cooking hoods, plenums, ducts, and filters with their associated cooking appliances, including deep fat fryers, ranges, broilers, griddles and similar grease-laden appliances;
- b) special grease removal devices;
- c) energy recovery devices installed in the exhaust system.

### **4.3 Applications**

**4.3.1** The manufacturer's installation and maintenance manual shall be consulted for the system's limitations and applications for which the approved system is considered satisfactory protection.

**4.3.2** Each protected cooking appliance, individual hood and branch exhaust duct directly connected to the hood, shall be protected by a system or systems designed for simultaneous operation.

**4.3.3** Where two or more hazards can be simultaneously involved in fire by reason of their proximity, the hazards shall be protected by either of the following:

- a) individual systems installed to operate simultaneously;
- b) a single system designed to protect all hazards that can be simultaneously involved.

**4.3.4** Any hazard that will allow fire propagation from one area to another shall constitute a single fire hazard.

#### **4.4 System actuation**

**4.4.1** All systems shall have a manual method of actuation or both manual and automatic actuations.

**4.4.2** The automatic and manual means of system actuation, external to the control head or releasing device, shall be separate and independent of each other so that a failure of one will not impair the operation of the other.

**4.4.3** When a releasing mechanism is used, employing a single line for the mechanical detection and the remote manual control, the remote manual control shall be installed inline, prior to all detection devices, so that a malfunction of one does not impede operation of the other.

**4.4.4** Automatic detection and system actuation shall be in accordance with the manufacturer's installation and maintenance manual.

**4.4.5** The devices necessary for the proper operation of the system shall function simultaneously with the system operation.

**4.4.6** Operation of any manual actuator shall be all that is required to bring about the full operation of the system.

**4.4.7** At least one manual actuator shall be provided for each system.

**4.4.8** All operating devices shall be designed, located, installed or protected so that they are not subject to mechanical, environmental or other conditions that could render them inoperative or cause inadvertent operation of the system.

**4.4.9** An audible or visual indicator shall be provided to show that the system has operated, that personnel response is needed and that the system is in need of recharge.

**4.4.10** The extinguishing system shall be connected to the fire alarm system, if provided, so that actuation of the extinguishing system will sound the fire alarm as well as provide the function of the extinguishing system.

**4.4.11** A readily accessible means for manual actuation shall be located in a path of egress. When manual activation is used for cooking related protection, the manual activation device shall be installed no more than 1 450 mm, nor less than 1 000 mm above the floor and shall clearly identify the hazard against which it protects.

**4.4.12** Automatic systems protecting common exhaust ducts shall not require a remote manual actuator.

**4.4.13** The means for the manual actuator(s) shall be mechanical and shall not rely on electrical power for actuation, except as provided for in [4.4.14](#).

**4.4.14** Electrical power shall be permitted to be used for the manual actuation if a reserve power supply is provided or if supervision in accordance with [4.5](#) is provided.

## **4.5 Supervision**

**4.5.1** Where supervision of any of the following is provided, it shall be designed to provide an indication of problems or failure:

- a) automatic detection system;
- b) electrical actuation circuit;
- c) electrical power supply.

**4.5.2** Signals indicating the failure of the supervised devices or equipment shall give prompt and positive indication of any failure and shall be distinctive from signals indicating operation or hazardous conditions.

## **4.6 System location**

**4.6.1** Agent containers and expellant gas assemblies shall be located within the temperature range specified in the manufacturer's installation and maintenance manual.

**4.6.2** If ambient temperatures outside the manufacturer's operating temperature range are expected, protection shall be provided to maintain the temperature within the approved range.

**4.6.3** Agent containers and expellant gas assemblies shall not be located where they could be subjected to mechanical, chemical, or other damage.

**4.6.4** Where damage due to chemical or mechanical exposure is expected, protective devices such as enclosures or guards shall be provided.

**4.6.5** Agent containers and expellant gas assemblies shall be accessible for inspection, maintenance, and recharge.

**4.6.6** Agent containers and expellant gas assemblies shall be located near the hazard or hazards protected but not where they will be exposed to the fire.

## **4.7 Discharge nozzles**

**4.7.1** All discharge nozzles shall be designed and subsequently located, installed, or protected so that they are not subjected to mechanical, environmental, or other conditions that would render them inoperative.

**4.7.2** Discharge nozzles shall be connected and supported.

## **4.8 Special requirements**

**4.8.1** Systems protecting two or more hoods or plenums, or both, shall be installed to ensure the simultaneous operation of all systems protecting the hoods, plenums and associated cooking appliances located below the hoods.

**4.8.2** A single detection device shall be permitted for more than one appliance when installed according to the system's approval detection arrangements.



**4.8.3** At least one heat detector or fusible link shall be installed within each exhaust duct opening in accordance with the manufacturer's approval.

**4.8.4** A heat detector or fusible link shall be provided above each protected cooking appliance and in accordance with the manufacturer's approval. Heat detectors or fusible links located at or within 300 mm into the exhaust duct opening and above the protected appliance shall be permitted to meet this requirement.

**4.8.5** Where the pipe or other conduit penetrates a duct or hood, the penetration shall have a liquid tight continuous external weld or shall be sealed by an approved device.

## **4.9 Protection of common exhaust duct**

**4.9.1** Common exhaust ducts shall be protected by one of the following methods:

- a) Simultaneous operation of all independent hood, duct, and appliance protection systems;
- b) Simultaneous operation of any hood, duct, and appliance protection system and the system(s) protecting the entire common exhaust duct.

**4.9.2** A heat detector or fusible link shall be located at each branch duct-to-common duct connection.

**4.9.3** Actuation of any branch duct-to-common duct exhaust duct heat detector or fusible link shall actuate the common duct system only, or when all independent systems are connected to a fire alarm control panel.

**4.9.4** All sources of fuel or heat to the appliances served by the common exhaust duct shall be shut down upon actuation of any protection system.

**4.9.5** Ignition sources contained within any exhaust system shall be protected and have a separate detection system in accordance with the manufacturer's recommendations and the approval testing.

**4.9.6** Moveable cooking equipment shall be provided with a means to ensure that it is correctly positioned in relation to the appliance discharge nozzles during cooking operations.

## **5 Test methods**

### **5.1 Cooking appliance extinguishing tests**

#### **5.1.1 General**

**5.1.1.1** An extinguishing system unit shall meet the coverage and nozzle placement limitations for each type of cooking appliance with which it is intended to be used. When the coverage and nozzle placement limitations from the results of successful deep fat fryer testing meet the requirements for any other cooking appliance installations, further testing is not required (see [5.1.2](#)). For cooking appliances with different nozzle coverage and placement limitations, fire tests are required.

Specific fire extinguishing test methods are given in [5.1](#). Additional testing on splashing during the discharge of a system, in accordance with [5.2](#), shall also be provided.

For hood, duct and broiler testing only, grease is to be new or used vegetable shortening, or rendered animal fat.

**5.1.1.2** When tested with a cooking appliance, the extinguishing system unit shall:

- a) result in the flame in the appliance being completely extinguished in one minute or less;
- b) after 10 seconds of the release of the system, not cause a fire ball over the appliance that is larger than the initial fire;
- c) for deep fat fryers, woks and ranges, not permit reigniting of the grease for 20 minutes or until the temperature of the grease decreases at least 33,3 °C below its observed auto-ignition temperature, whichever is longer; and
- d) for all appliances other than deep fat fryers, woks and ranges, not permit re-ignition of the grease for five minutes.

**5.1.1.3** Unless otherwise noted, each fire test shall be conducted using the minimum quantity of agent and the minimum discharge rate condition which is achieved by assembling the extinguishing system using its maximum piping limitations with respect to the number of fittings and the size and length of the pipe in accordance with the manufacturer's installation instructions.

**5.1.1.4** The cylinder/valve assembly shall be filled to its rated capacity and the cylinder or gas cartridge pressurized with the expellant gas to the normal operating pressure at 21 °C [see 6.2 k)]. The cylinder/valve assembly or gas cartridge used for these tests shall be conditioned for at least 16 h at the minimum storage temperature specified in the manufacturer's installation instructions. As an alternative to the conditioning, stored pressure units may be under-pressurized to simulate the pressure at the minimum operating temperature.

**5.1.1.5** Extinguishing tests shall be conducted with both the maximum and minimum nozzle heights, with each nozzle positioned in the most difficult location and orientation allowed by the manufacturer's installation instruction with respect to fire extinction. Splash tests shall be conducted at the minimum nozzle height, with the nozzle positioned in the most difficult locations and orientations allowed by the installation instructions.

**5.1.1.6** The length and width of the cooking area of the appliance being tested shall correspond to the maximum area coverage and dimension limitations specified in the installation instructions.

**5.1.1.7** Multiple-appliance protection for single discharge nozzle coverage shall be tested as per the manufacturer's installation instructions.

**5.1.1.8** A larger appliance shall not be protected with multiple nozzles unless:

- a) a deep fat fryer protected by multiple nozzles does not exceed a total cooking surface area of 0,55 m<sup>2</sup>;
- b) the area of coverage for each nozzle does not exceed its single appliance coverage.

The following are exceptions to the requirements of this subclause.

- 1) When compliance with the deep fat fryer requirements is demonstrated using the specified cooking surface area of coverage, the protection of a deep fat fryer with a total cooking surface area greater than 0,55 m<sup>2</sup> may be used.
- 2) The 0,55 m<sup>2</sup> total surface cooking area requirement does not apply to tilt skillets/braising pans.

**5.1.1.9** Prior to the conduct of each extinguishing test, the appliance shall be cleaned and provided with new cooking grease.

## **5.1.2 Deep fat fryer**

**5.1.2.1** The deep fat fryer used for this test shall be a commercially available natural gas, propane, or electric deep fat fryer, at least 230 mm deep, having a cooking surface area as specified in the

manufacturer's installation instructions. For a deep fat fryer with an integral drip board, or the like, the calculated cooking area, along with the drip area, shall be as indicated in the manufacturer's installation instructions.

**NOTE** On certain electric fryers, the heating elements can be damaged due to the high temperatures during the fire testing; therefore, natural gas or propane fuelled units are commonly used for the fire tests.

**5.1.2.2** All deep fat fryers tested in accordance with [5.1.2.1](#), and [5.1.2.3](#) to [5.1.2.8](#) shall demonstrate an average heating rate of not less than 7 °C/min and an average cooling rate of not more than 3 °C/min. The average heating and cooling rates shall be determined by heating the liquid grease in an uncovered fryer at the fryer's maximum energy input. The time required to heat the grease from 260 °C to 315 °C shall be used to calculate the rise in temperature of the appliance. When the temperature of the liquid grease reaches 325 °C, the fryer's energy source shall be immediately shut off. The temperature of the cooling liquid grease shall then be monitored. When the temperature of the grease returns to 315 °C, the cooling rate, in °C per minute, shall be measured between the temperatures of 315 °C and 260 °C. The fryer shall be tested with an ambient temperature of (21 ± 5) °C throughout the duration of the test. The thermocouple monitoring the grease temperature shall be installed as indicated in [5.1.2.6](#).

**5.1.2.3** Multiple-vat and split-vat deep fat fryers shall be separately tested with the discharge nozzle positioned in the most difficult location and orientation allowed by the manufacturer's installation manual.

**5.1.2.4** Split-vat fryers shall be tested wherein one or more of the vats adjacent to the vat to be spontaneously ignited are filled with liquid cooking grease and heated to 175 °C to 190 °C. Energy shut-off for all the vats shall occur when the extinguishing system is actuated.

If saponified foam from the adjacent vat(s) rolls over into the burning vat after system actuation, the grease temperature of the adjacent vat(s) shall be reduced to the point where foam rollover does not occur or a means shall be provided to prevent foam from rolling over into the burning vat.

**5.1.2.5** The fryer shall be filled with new, unused liquid grease until the grease level is 75 mm below the top edge of the fryer (see [5.1.1.9](#)). The liquid grease shall have an auto-ignition temperature not less than 363 °C when tested with the deep fat fryers of the type specified in [5.1.2.1](#). During the testing, the auto-ignition temperature shall not be less than 358 °C and the commencement of the timing of the two minute free burn shall start at an oil temperature of 363 °C. For a deep fat fryer with an internal drip board, or the like, the grease level shall be at the fryer wall/drip board interface, when the grease is at a temperature of 175 °C to 190 °C. In no case shall the grease level for any type of fryer be more than 75 mm below the top of the vat when the grease temperature is between 288 °C to 315 °C.

**5.1.2.6** The grease temperature during testing shall be measured with a thermocouple located 25 mm below the grease surface. The thermocouple shall be located not closer than 75 mm to any side of the fryer.

**5.1.2.7** The liquid grease in the fryer shall be heated by its heating source until auto-ignition occurs. If the grease temperature reaches 363 °C and the grease has not ignited, it shall be ignited manually. The fire shall burn freely with the fryer's heating source remaining on for a period of not less than two minutes. After the free-burn period, the heating source shall be shut off and the extinguishing system shall be manually discharged.

**5.1.2.8** Upon complete discharge of the extinguishing agent, the deep fat fryer shall have complied with the requirements in [5.1.1.2](#).

### **5.1.3 Griddle**

**5.1.3.1** The griddle used for the fire test is to be constructed of sheet metal at least 2 mm thick and is to be 25 mm deep.

**5.1.3.2** The griddle is to be filled with liquid grease to a depth of 6 mm.

**5.1.3.3** The liquid grease in the griddle is to be heated by the griddle's heating source until spontaneous ignition occurs. After the cooking area is fully involved in flames, the fire is to burn freely for a minimum of one minute, with the heating source remaining on, after which the heating source is to be shut off and the extinguishing system unit is to be discharged.

**5.1.3.4** Upon complete discharge of the extinguishing agent, the griddle shall comply with the requirements of [5.1.1.2](#).

#### **5.1.4 Range top**

**5.1.4.1** The range top used for the test is to be a commercially available electric, natural gas or propane fired range top or a commercial range top burner constructed to simulate variable range top configurations. When a manufacturer references protection for a range top incorporating a back shelf, a back shelf of the maximum size and located at the minimum height as specified in the manufacturer's installation instructions is to be used for the test. The cooking surfaces of the range top are to be the maximum as specified for coverage in the manufacturer's installation, operation and maintenance manual.

**5.1.4.2** The following test vessels are to be used for the tests:

- a) a cast iron skillet having a diameter of 330 mm to 360 mm at the top and having sides 45 mm to 60 mm high, measured from inside the skillet;
- b) a stainless steel pot having a diameter of  $(255 \pm 6)$  mm at the top and having sides of 180 mm to 200 mm high.

**5.1.4.3** Separate extinguishment tests are to be conducted using each test vessel.

**5.1.4.4** For the test with the cast iron skillet, the skillet is to be filled with liquid grease to a depth of 25 mm. For the test with the stainless steel pot, the pot is to be filled with liquid grease to a depth of 100 mm. The grease level is to be measured when the grease temperature is between 288 °C to 315 °C.

**5.1.4.5** The liquid grease is to have an auto-ignition temperature of not less than 363 °C. The auto-ignition temperature shall not be less than 349 °C when the two minute free burn commences at an oil temperature of 363 °C. The grease temperature is to be measured with a thermocouple located 12,5 mm below the grease surface and not closer than 75 mm to the test vessel wall.

**5.1.4.6** The test vessel is to be positioned on a burner in a location determined to be the most difficult to achieve fire extinguishment. For the skillet test, the 255 mm pot is to be located adjacent to the skillet in a location determined to be the most difficult with respect to achieving fire extinguishment. The range top burner for the test vessel is to be adjusted to the maximum intensity position and the grease continuously heated until auto-ignition occurs. After auto-ignition, the fire is to burn freely with the burner at its maximum intensity for a period of not less than 2 min. After the free-burn period of not less than 2 min, the heating source is to be shut off and the extinguishing system unit is to be discharged.

**5.1.4.7** Upon complete discharge of the extinguishing agent, the range top shall comply with the requirements of [5.1.1.2](#).

#### **5.1.5 Gas radiant char-broiler**

**5.1.5.1** A commercially available gas radiant char-broiler or a char-broiler constructed to simulate a commercially available gas radiant char-broiler is to be used for the test. The char-broiler is to have a drip pan at least 12,5 mm deep located below the heating source. An extinguishing system unit is capable of being used with an electric char-broiler based on a successful extinguishment test using a gas radiant char-broiler using identical coverage and nozzle placement limitations.

**5.1.5.2** A thin plastic sheet, such as plastic food wrap, containing steaks and grease is to be placed on a flat surface at a location away from the char-broiler. The plastic sheet is to be covered with 6 mm of semi-solid grease. Low quality fatty beef steaks are then to be placed on top of the grease-laden plastic sheet so as to cover an area equal to 80 % to 90 % of the char-broiler grate area. The drip pan is to be filled with 3 mm of liquid grease.

**5.1.5.3** The char-broiler's radiant panels are to be heated with the burners at their maximum intensity so that they are hot enough to ignite drops of liquid grease. When this occurs, the plastic sheet, grease and steaks are to be placed on the broiler's grill in the normal cooking position. The char broiler is to become quickly involved in flames. The heating source is to be shut off and the extinguishing system discharged after the cooking area has been fully covered with flames for one minute and the peak flame height is at least 900 mm.

**5.1.5.4** Upon complete discharge of the extinguishing agent, the gas radiant char-broiler shall comply with the requirements in [5.1.1.2](#).

### **5.1.6 Electric char-broiler**

**5.1.6.1** A commercially available electric char-broiler, or a char-broiler constructed to simulate a commercially available electric char-broiler is to be used for the test.

**5.1.6.2** The test is to be conducted in the same manner as the gas radiant test specified in [5.1.5.1](#) to [5.1.5.4](#).

### **5.1.7 Lava, pumice or synthetic rock char-broiler**

**5.1.7.1** Identical coverage and nozzle placement limitations for lava rock, pumice stone or synthetic rock type char-broilers is to be used based on a successful extinguishment test of a lava rock type char-broiler. A gas or electrically heated char-broiler is to be used, and an extinguishing system unit can be used with either heat source based on a successful extinguishment test using either heat source.

**5.1.7.2** A commercially available lava, pumice or synthetic rock char-broiler, or a char-broiler constructed to simulate a commercially available lava, pumice or synthetic rock char-broiler, is to be used for the test.

**5.1.7.3** This test is to be conducted in the same manner as the gas radiant test specified in [5.1.5.1](#) to [5.1.5.4](#), except that the lava, pumice, or synthetic rock is to be heated in lieu of heating the gas radiant panels. The grate is to be covered with two layers of lava, pumice, or synthetic rock, whichever is being used for test purposes.

### **5.1.8 Natural charcoal broiler**

**5.1.8.1** A commercially available charcoal broiler or a charcoal broiler constructed to simulate a commercially available charcoal broiler is to be used for the test.

**5.1.8.2** A thin plastic sheet, such as plastic food wrap, containing steaks and grease is to be placed on a flat surface at a location away from the charcoal broiler. The plastic sheet is to be covered with 6 mm of semi-solid grease. Low quality fatty beef steaks are then to be placed on top of the grease-laden plastic sheet so as to cover an area equal to 80 % to 90 % of the cooking area.

**5.1.8.3** The fuel grate is then to be covered with charcoal briquettes to the maximum depth limitation specified in the installation instructions. In any case, the charcoal depth is not to be less than two layers of briquettes.

**5.1.8.4** The charcoal briquettes are then to be heated until they are covered with ash. When this occurs, the plastic sheet, grease and steaks are to be placed on the broiler's grill in the normal cooking position. The broiler shall become quickly involved in flames. The fire is to burn freely until the cooking area is fully involved in flames having a height of 900 mm, and the fire is to be allowed to burn for at least 30 seconds. When the cooking area is fully involved in flames and after 30 seconds or longer of flaming, the extinguisher system unit is to be discharged.

**5.1.8.5** Upon complete discharge of the extinguishing agent, the charcoal broiler shall comply with the requirements in [5.1.1.2](#).

### **5.1.9 Mesquite wood char-broiler**

**5.1.9.1** A commercially available mesquite wood char-broiler or a char-broiler constructed to simulate a commercially available mesquite wood char-broiler is to be used for the test. The test is to be conducted using the type of mesquite wood that is intended to be used with the char-broiler.

**5.1.9.2** The test is to be conducted in the same manner as the natural charcoal broiler test specified in [5.1.8.1](#) to [5.1.8.5](#) except that the fuel depth is to be the maximum specified by the manufacturer, and in no case less than 75 mm, and mesquite wood is to be used instead of charcoal.

### **5.1.10 Upright broiler**

**5.1.10.1** A commercially available upright broiler or an upright broiler constructed to simulate a commercially available upright broiler is to be used for the test. The broiling chamber is to be located at or about the mid-height of the broiler and is to incorporate a broiling grate. A drip pan is to be placed directly below the broiling chamber. The bottom of the broiling chamber is to slope downward towards the drip pan and have an opening to allow the drainage of the grease from the broiling chamber. The broiling chamber is also to incorporate a completely enclosed warming chamber directly above the broiling chamber. The broiling chamber is to be connected by internal passages to the top of the broiler to provide for exhaust of the grease-laden vapours. The broiler is to incorporate a grease trap.

**5.1.10.2** The drip pan below the broiler chamber is to be filled with preheated grease. The inner surfaces of the broiling chamber, the exhaust passages, and the grease trap in the back of the broiler are to be coated with the liquid grease to obtain a minimum loading of 1,5 kg/m<sup>2</sup>.

**5.1.10.3** Following the grease loading, low quality fatty beef steaks are to be placed on the broiler grate so as to cover an area of between 80 % and 90 % of the cooking area.

**5.1.10.4** The grease in the drip pan and broiling chamber is to be heated with a torch until the broiler is well involved in flames. This usually requires two to three minutes. After complete flame coverage of the drip pan, the broiler is then to burn freely for an additional 30 to 60 seconds, after which the extinguishing system unit is to be discharged.

**5.1.10.5** Upon complete discharge of the extinguishing agent, the upright broiler shall comply with the requirements in [5.1.1.2](#).

### **5.1.11 Chain broiler**

**5.1.11.1** A commercially available chain broiler or a chain broiler constructed to simulate a commercially available chain broiler is to be used for the test. The bottom of the broiling chamber is to slope downward toward a drip pan and have an opening to allow the drainage of the grease from the broiler chamber.

**5.1.11.2** The drip pan below the broiler chamber is to be filled with preheated grease. The inner surfaces of the broiler chamber, cooking portion and grease trap are to be coated with liquid grease to obtain a

minimum loading of 1,5 kg/m<sup>2</sup>. Grease is also to be sprayed on all areas of the chain by causing the chain to rotate. When this is complete, 80 % to 90 % of the chain's cooking area is to be covered with fatty hamburgers (i.e. meat that is 70 % lean) and the chain rotation stopped.

**5.1.11.3** The grease in the drip pan and the broiler chamber is to be heated with the broiler's burners and a torch or with a torch only until the broiler is well involved in flames. This usually requires two to three minutes. The broiler is then to burn freely for an additional 30 s to 60 s after which the extinguishing system unit is to be discharged.

**5.1.11.4** Upon complete discharge of the extinguishing agent, the chain broiler shall comply with the requirements in [5.1.1.2](#).

## **5.1.12 Wok**

**5.1.12.1** The minimum and maximum wok sizes specified in the manufacturer's installation, operation and maintenance instruction manual are to be tested. The wok sizes are to be determined by the minimum and maximum height and diameter.

**5.1.12.2** The heating source used for the tests is to be a commercially available electric, natural gas, or propane fired range top.

**5.1.12.3** Separate extinguishment tests are to be conducted using the smallest and the largest representative wok.

**5.1.12.4** Each wok is to be tested with a liquid grease level at a depth that provides a 75 mm freeboard measured from the top edge of the wok, or a minimum grease level of 25 mm, whichever provides greater depth of grease. The grease level is to be measured when the grease temperature is between 288 °C to 315 °C.

**5.1.12.5** The liquid grease is to have an auto-ignition temperature of not less than 349 °C when the two minute free burn commences at an oil temperature of 362 °C. The grease temperature is to be measured with a thermocouple located 12,5 mm below the grease surface not closer than 75 mm to the test vessel wall.

**5.1.12.6** The wok is to be positioned on a burner in a location determined to be the most difficult to achieve fire extinguishment. For the minimum size wok test, a maximum size wok is to be located adjacent to the test wok representing the location most difficult to achieve fire extinguishment. The range top burner for the test wok is to be adjusted to a maximum intensity position and the grease continuously heated until auto-ignition occurs. After auto-ignition, the fire is to burn freely with the burner at maximum intensity for a period of not less than two minutes. After the free-burn period of not less than two minutes, the heating source is to be shut off and the extinguishing system unit is to be discharged.

**5.1.12.7** Upon complete discharge of the extinguishing agent, the wok shall comply with the requirements in [5.1.1.2](#).

## **5.2 Splash tests**

### **5.2.1 Deep fat fryer extinguishing splash tests**

**5.2.1.1** When tested as described in [5.2.1.3](#) to [5.2.1.10](#), an extinguishing system unit shall:

- a) result in the fire in a deep fat fryer being completely extinguished; and
- b) result in no splashing of burning droplets of grease due to the extinguishing system unit operation, as evidenced by the presence of burning grease dispersed outside the fryer.

**5.2.1.2** The deep fat fryer used for this test shall be as specified in [5.1.2](#).

**5.2.1.3** The splash test shall be conducted using the maximum discharge rate condition for the test nozzle or nozzles.

NOTE The maximum discharge rate condition is generally obtained by using the maximum piping diameter, the minimum piping length, the minimum number of tees and elbows and the cylinder or gas cartridge conditioned to the maximum operating temperature for which the extinguishing system is intended.

**5.2.1.4** The nozzle shall be located at the minimum height specified by the manufacturer's installation manual and positioned in the orientation most likely to create splashing of the hot grease.

**5.2.1.5** The fryer is to be filled with liquid grease as specified in [5.1.2.5](#).

**5.2.1.6** The grease temperature during testing shall be measured with a thermocouple installed as specified in [5.1.2.6](#).

**5.2.1.7** The liquid grease is to be heated as specified in [5.1.2.7](#).

**5.2.1.8** The fire shall burn freely until the cooking area is fully involved in flames having a height of approximately 900 mm and shall be allowed to burn for at least two minutes. At the end of two minutes, the heat source is to be shut off and the extinguishing system unit released manually.

**5.2.1.9** When the cooking area is fully involved in flames, the extinguishing system unit shall be discharged and the discharge effects observed to determine compliance with the requirements in [5.2.1.1](#). Foaming over the edge of the fryer and dispersion of residual extinguishing agent on the surrounding surface area in the vicinity of the discharge nozzle is acceptable.

**5.2.1.10** Upon complete discharge of the extinguishing agent, the deep fat fryer shall comply with the requirements in [5.1.1.2](#).

## **5.2.2 Deep fat fryer cooking temperature splash test**

**5.2.2.1** When tested as described in [5.2.2.2](#) to [5.2.2.8](#), an extinguishing system unit shall not splash grease droplets in excess of 5 mm diameter.

**5.2.2.2** The deep fat fryer used for the tests is to be as specified in [5.1.2](#).

**5.2.2.3** The test is to be conducted using the maximum discharge rate condition for the test nozzle or nozzles. The maximum discharge rate condition is obtained by using the maximum pipe diameter, minimum piping length and minimum number of tees and elbows, with the cylinder or gas cartridge conditioned to the maximum operating temperature for at least 16 h or pressurized to the maximum pressure corresponding to the maximum operating temperature for which the extinguishing system unit is intended.

**5.2.2.4** The nozzle shall be located at the minimum height specified by the manufacturer's installation manual and positioned in the orientation most likely to create splashing of the hot grease.

**5.2.2.5** The fryer is to be filled with liquid grease until the grease level is 75 mm below the top edge of the fryer. The grease level is to be measured when the grease temperature is between 177 °C to 191 °C

**5.2.2.6** The grease temperature during the test is to be measured with a thermocouple as indicated in [5.1.2.6](#).



**5.2.2.7** A flat metallic surface at least 760 mm wide having not more than a 1,6 mm deep layer of sodium bicarbonate dry chemical placed on top of the surface is to be prepared around the front and sides of the fryer to detect splashing grease. The liquid grease in the fryer is to be heated by its heating source until a grease temperature of 177 °C to 191 °C is achieved. The extinguishing system unit is then to be discharged for three to five seconds. The metallic surface is to be removed from around the fryer at the end of the discharge to prevent foaming over the edge from contaminating the results.

**5.2.2.8** The discharge effects are to be observed to determine compliance with the requirements in [5.2.2.1](#). Foaming over the edge of the fryer and dispersion of residual extinguishing agent on the surrounding area in the vicinity of the discharge nozzle is acceptable.

### **5.2.3 Range top extinguishing splash tests**

**5.2.3.1** When tested as described in [5.2.3.2](#) to [5.2.3.7](#), an extinguishing unit shall:

- a) result in the fire in a cast iron skillet being completely extinguished; and
- b) result in no splashing of the burning grease due to the extinguishing system unit operation, as evidenced by the presence of burning droplets of grease dispersed outside the cast iron skillet.

**5.2.3.2** The range top used for this test is to be as specified in [5.1.4](#) and the cast iron skillet as specified in [5.1.4.2](#) a).

**5.2.3.3** The test is to be conducted using the maximum discharge rate condition for the test nozzle or nozzles. The maximum discharge rate condition is obtained by using the maximum pipe diameter, minimum piping length and minimum number of tees and elbows, with the cylinder or gas cartridge conditioned to the maximum operating temperature for at least 16 hours or pressurized to the maximum pressure corresponding to the maximum operating temperature for which the extinguishing system unit is intended.

**5.2.3.4** The cast iron skillet is to be filled with liquid grease as specified in [5.1.4.4](#).

**5.2.3.5** The grease temperature during the testing is to be measured as specified in [5.1.4.5](#).

**5.2.3.6** The cast iron skillet is to be positioned on a burner located so as to result in splashing of grease. The range top burner for the skillet is to be adjusted to the maximum intensity position and the grease heated with the skillet uncovered until auto-ignition occurs. After auto-ignition, the fire is to burn freely with the burner at its maximum intensity for a period of not less than two minutes, after which the heat source is to be shut off and the extinguishing system unit discharged.

**5.2.3.7** The discharge effects are to be observed to determine compliance with the requirements in [5.2.3.1](#).

### **5.2.4 Range top cooking temperature splash tests**

**5.2.4.1** When tested as described in [5.2.4.2](#) to [5.4.2.6](#), an extinguishing system unit shall not splash grease droplets in excess of 5 mm diameter.

**5.2.4.2** The test requirements specified in [5.1.4.2](#), [5.1.4.4](#) and [5.1.4.5](#) are to be used for the test.

**5.2.4.3** The test is to be conducted using the maximum discharge rate condition for the test nozzle or nozzles. The maximum discharge rate condition is obtained by using the maximum pipe diameter, minimum piping length and minimum number of tees and elbows, with the cylinder or gas cartridge conditioned to the maximum operating temperature for at least 16 h or pressurized to the maximum pressure corresponding to the maximum operating temperature for which the extinguishing system unit is intended.

**5.2.4.4** The cast iron skillet is to be filled with liquid grease until the grease level is 25 mm below the edge of the skillet. The grease level is to be measured when the grease temperature is 177 °C to 191 °C.

**5.2.4.5** A flat metallic surface at least 760 mm wide having not more than a 1,6 mm deep layer of sodium bicarbonate dry chemical placed on top of the surface is to be prepared around the front and sides of the range top to detect splashing grease. The liquid grease in the skillet is to be heated by its heating source until a grease temperature of 177 °C to 191 °C is achieved. The extinguishing system unit is then to be discharged for three to five seconds.

**5.2.4.6** The discharge effects are to be observed to determine compliance with the requirements in [5.2.4.1](#).

## **5.2.5 Wok extinguishing splash test**

**5.2.5.1** When tested as described in [5.2.5.2](#) to [5.2.5.6](#), an extinguishing unit shall:

- a) result in the fire in a wok being completely extinguished; and
- b) result in no splashing of the burning grease due to the extinguishing system unit operation, as evidenced by the presence of burning droplets of grease dispersed outside the wok.

**5.2.5.2** The wok used for this test is to be as specified in [5.1.12](#).

**5.2.5.3** The test is to be conducted using the maximum discharge rate condition for the test nozzle or nozzles. The maximum discharge rate condition is obtained by using the maximum pipe diameter, minimum piping length and minimum number of tees and elbows, with the cylinder or gas cartridge conditioned to the maximum operating temperature for at least 16 h or pressurized to the maximum pressure corresponding to the maximum operating temperature for which the extinguishing system unit is intended.

**5.2.5.4** The wok is to be filled with liquid grease as specified in [5.1.12.4](#).

**5.2.5.5** The grease temperature during the testing is to be measured as specified in [5.1.12.5](#).

**5.2.5.6** The wok is to be positioned on a burner located so as to result in splashing of grease. The range top burner for the wok is to be adjusted to the maximum intensity position and the grease heated with the wok uncovered until auto-ignition occurs. After auto-ignition, the fire is to burn freely with the burner at its maximum intensity for a period of not less than two minutes, after which the heat source is to be shut off and the extinguishing system unit discharged.

**5.2.5.7** The discharge effects are to be observed to determine compliance with the requirements in [5.2.5.1](#).

## **5.2.6 Wok cooking temperature splash tests**

**5.2.6.1** When tested as described in [5.2.6.2](#) to [5.2.6.6](#), an extinguishing system unit shall not splash grease droplets in excess of 5 mm diameter.

**5.2.6.2** The woks used for this test are to be as specified in [5.1.12](#).

**5.2.6.3** The test requirements specified in [5.1.12.4](#) to [5.1.12.6](#) are to be used for the test.

**5.2.6.4** The test is to be conducted using the maximum discharge rate condition for the test nozzle or nozzles. The maximum discharge rate condition is obtained by using the maximum pipe diameter, minimum piping length and minimum number of tees and elbows, with the cylinder or gas cartridge conditioned to the

maximum operating temperature for at least 16 h or pressurized to the maximum pressure corresponding to the maximum operating temperature for which the extinguishing system unit is intended.

**5.2.6.5** The wok is to be filled with liquid grease until the grease level is 75 mm below the top edge of the wok. The grease level is to be measured when the grease temperature is 177 °C to 191 °C.

**5.2.6.6** A flat metallic surface at least 762 mm wide having not more than a 1,6 mm deep layer of sodium bicarbonate dry chemical placed on top of the surface is to be prepared around the front and sides of the range top to detect splashing grease. The liquid grease in the skillet is to be heated by its heating source until a grease temperature of 177 °C to 191 °C is achieved. The extinguishing system unit is then to be discharged for three to five seconds.

**5.2.6.7** The discharge effects are to be observed to determine compliance with the requirements in [5.2.6.1](#).

### **5.3 Hood and duct (full scale) extinguishing test**

#### **5.3.1 General**

**5.3.1.1** An extinguishing system unit intended to protect the hood and duct of a galley cooking area is to be tested as described below.

#### **5.3.2 Hood**

**5.3.2.1** The hood dimensions are to be the maximum as specified in the installation instructions. Refer to [Figure 1](#).

**5.3.2.2** The hood is to be at least 1,2 m wide, increasing in increments of 0,3 m only.

**5.3.2.3** The hood is to be 1,2 m, 1,7 m, 2,4 m, 3,6 m, 4,2 m, 4,9 m, 6,1 m or 7,3 m long. Hoods longer than 7,3 m are to be in increments of 1,8 m only.

**5.3.2.4** The hood is to be constructed of sheet metal having a minimum thickness of 2 mm.

#### **5.3.3 Filter and frame**

**5.3.3.1** The filter frame is to be a “V” type extending the full length of the hood. The bottom portion of the filter frame is to be constructed of 50 mm by 50 mm angle iron having a minimum thickness of 3 mm. Steel mesh type filters are to be installed at a  $(45 \pm 10)^\circ$  inclined position on both sides of the “V”. During the extinguishing tests, the cooking appliance is to be located below the hood and filters. The hood and filters are to extend beyond each end of the appliance. See [Figure 1](#).

The filter frame is not required to be a “V” type when another type of filter frame configuration, such as one using a single bank of filters, is specified in the installation instructions.

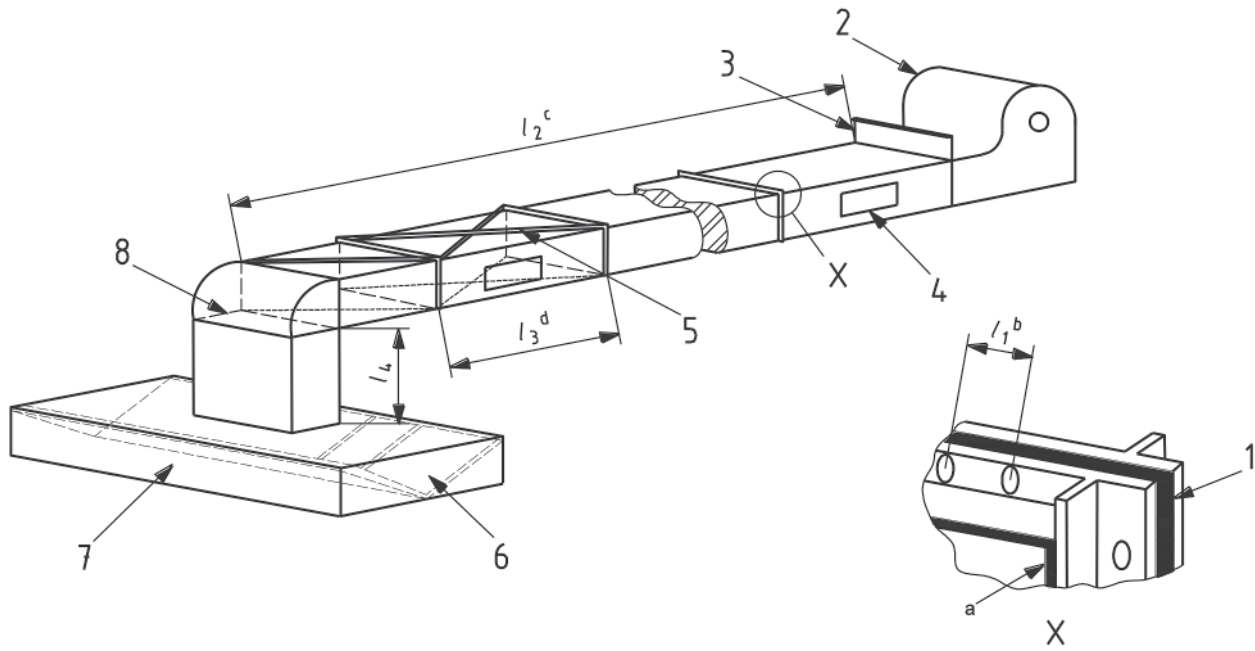

**Key**

- 1 gasketing material
- 2 blower capable of providing 2,54 m/s to 5,08 m/s air velocity (approximately equivalent to 500 ft/min to 1 000 ft/min)
- 3 damper
- 4 access ports provided every 2,43 m or less (approximately equivalent to 8 ft)
- 5 angle iron supports to minimize warping and flexing
- 6 filters, 50,8 mm thickness (equivalent to 2 in), steel mesh type
- 7 hood
- 8 dam, 12,7 mm (equivalent to 1/2 in), optional
- $l_1$  102 mm (approximately equivalent to 0,33 ft)
- $l_2$  22 900 mm (approximately equivalent to 75 ft)
- $l_3$  1 200 mm (approximately equivalent to 4 ft)
- $l_4$  0 mm to 900 mm (approximately equivalent to 0 ft to 3 ft)
- a Welded seam all around
- b Space between bolts, all around
- c Minimum dimension; for unlimited duct length specification see installation instructions
- d Duct sections

NOTE The duct can be located in the middle or end of the hood.

**Figure 1 — Typical test apparatus for hood and duct testing**

**5.3.4 Duct**

**5.3.4.1** The duct is to be rectangular or round, and an extinguishing system unit tested using a rectangular duct can be used in a round duct having a circumference equal to or less than the perimeter of the of the rectangular duct. An extinguishing system unit to be used with round ducts only is to be tested using a round duct only. See [Figure 1](#).

**5.3.4.2** The duct perimeter is to be the maximum specified in the installation instructions.

**5.3.4.3** The perimeter of a rectangular duct is to be 1,24 m or less, 1,90 m, 2,54 m, 3,17 m, 3,81 m or 7,62 m or larger. The diameter of a circular duct is to be 0,61 m, 0,81 m, 1,02 m, 1,22 m, or 2,4 m or larger. A rectangular duct is to be installed with the longest side horizontal and the ratio between vertical and horizontal is to be 1:2,  $\pm 10\%$ .

**5.3.4.4** The duct is to be 6,1 m, 15,2 m, or 22,9 m long or other intermediate lengths as specified by the manufacturer of the extinguishing system unit. If the 22,9 m length is used, the extinguishing system unit should be capable of being installed without limitation to the maximum duct length. Access ports are to be provided at least every 2,4 m along the duct to permit the inspection and greasing of the duct. Duct sections are to be provided with gaskets to prevent the leakage of grease at the point of connection. The gasket material is to be made of a material that withstands the heat exposure generated during the test. The duct is to be supported at least every 2,4 m to help maintain the duct integrity.

**5.3.4.5** The duct is to have a downward slope toward the hood of 25,4 mm to 76,2 mm for every 3 m of duct length so that a stream of liquid grease, for test purposes, flows from the duct onto the filters. The duct is to have a 0 mm to 900 mm high riser to connect the hood and the horizontal run of the duct. At the point at which the horizontal run of the duct connects to the riser, a 12,5 mm high dam is to be used on the bottom of the duct to allow an amount of grease to remain in the duct throughout the test period.

**5.3.4.6** At the outlet of the duct, an exhaust blower and damper is to be provided to permit adjustment of air velocity through the filters and the duct.

## **5.4 Extinguishing system unit test**

### **5.4.1 Preparation**

**5.4.1.1** Representative samples of the extinguishing system units are to be subjected to the tests specified in [5.4.2](#).

**5.4.1.2** Hood and duct extinguishment are to be conducted using the minimum discharge rate condition for the test nozzles.

**5.4.1.3** To obtain the minimum discharge rate condition, an extinguishing system unit is to be assembled using its maximum piping limitations with respect to the number of fittings and the size and length of pipe. The cylinder is to be filled to its rated capacity and the cylinder or gas cartridge pressurized with the expellant gas to the normal operating pressure at 21 °C [see [6.2 k](#)]. The cylinder or gas cartridge used for these tests is to be conditioned, after charging, for at least 16 h at the minimum storage temperature prior to the tests. As an alternative to conditioning at the minimum storage temperature for 16 h, extinguishing system units that utilize dry nitrogen or dry air as an expellant gas are to be tested by under-pressurizing the cylinder or gas cartridge at the ambient temperature to simulate the minimum operating temperature.

**5.4.1.4** Using the test arrangement described in [5.4.1.3](#), the nozzles are to be placed at the most difficult location and orientation allowed by the installation instructions with respect to achieving extinguishment.

**5.4.1.5** The test fuel used to load the cooking appliance is to be new vegetable shortening incorporating an antifoaming agent. The test fuel used to load the duct, filters and hood for full scale testing is to be either vegetable shortening incorporating an antifoaming agent or rendered animal fat.

### **5.4.1.6 Temperature measurement**

The interior of the duct is to be provided with thermocouples located 3,6 m and 6,1 m from the duct entrance. The thermocouples are to be the K type (chromel-alumel) of 0,82 mm<sup>2</sup> or 0,52 mm<sup>2</sup> wire with an untwisted welded bare bead junction not more than 1,27 mm diameter. The thermocouples are to be

located at the centre of the cross section of the duct and are to be connected to chart recorders or other equivalent means for monitoring thermocouple temperature.

#### 5.4.1.7 Deep fat fryer

Each full scale test is to be conducted with a deep fat fryer located under the hood and directly below the duct entrance. The distance between the deep fat fryer and the hood entrance is to be convenient for the test installation. The deep fat fryer is to be fully involved in flames prior to the 30 s countdown specified in [5.4.3.3](#).

### 5.4.2 General test procedures

**5.4.2.1** An extinguishing system unit intended for use with the hood and duct systems is to be tested as described in [5.4.2.2](#) to [5.4.5.2](#).

**5.4.2.2** Hood and duct (full scale) testing is to be conducted using a deep fat fryer as specified in [5.1.2.1](#).

In lieu of using the fryer specified in [5.1.2.1](#), a fryer having the same cooking surface area specified in the manufacturer's installation instructions and fabricated of sheet metal at least 2 mm thick, and at least 230 mm deep may be used.

**5.4.2.3** The test apparatus for the hood and duct (full scale) testing is to be as specified in [5.3.2](#) to [5.3.4](#).

**5.4.2.4** An extinguishing system unit is to be tested using the maximum coverage limitations specified in the installation instructions.

#### 5.4.2.5 Fuel loading

The test fuel grease is to be heated until liquefied and poured into a device required for uniformly coating the inside surfaces of the duct and plenum chamber, such as a 9 l stored pressure water fire extinguisher pressurized in the normal manner. When an extinguisher is used, a discharge assembly other than that provided with the extinguisher can be used to provide for a spray discharge. The interior surfaces of the duct and plenum chamber are to be evenly coated with the grease to obtain a minimum loading of 1,5 kg/m<sup>2</sup>. Additional grease can be used, particularly on large size ducts, to obtain the required sustained fire. Alternative grease application methods that achieve equivalent results can be used. The filters are to be loaded with a minimum of 3,7 kg/m<sup>2</sup> of filter area. This is to be done by spraying, dipping or spreading solid grease onto each filter.

**5.4.2.6** Duct Air Flow Tests are to be conducted in the following airflow/damper conditions:

- a) duct outlet open at all times with no exhaust blower assistance after ignition;
- b) duct outlet closed by the damper immediately before system actuation;
- c) 150 m/min to 300 m/min velocity in the duct, achieved by using the exhaust blower assistance. The airflow in the duct is to be adjusted after ungreased filters are installed to obtain the appropriate discharge rates specified below. Instruments such as velometers or piezometers are to be used for checking the air velocity and making adjustments. A minimum of 9 measurement points are to be averaged to determine the velocity in the duct. The measurements are to be taken downstream of the hood and determined by dividing the cross section of the duct into 16 equal subsections. The measuring device is to be located at the point of intersection of the boundaries forming each section. An alternative means for measuring velocity is to be used when judged to provide equivalent results.

### 5.4.3 Fuel ignition and extinguishing system unit operation

**5.4.3.1** The ignition of the fire in the fryer, hood, and duct is to be initiated by external sources. Gas burners, propane burners, hand-held propane torches, or similar items are sources of ignition. Previous testing has indicated that external heating sources applied under the hood and generating a heat output of between 15 800 kJ/min and 21 100 kJ/min are capable of igniting the hood area and duct. The ignition of the grease in the deep fat fryer is to be made using the fryer's integral or an external heating source. Flammable liquids, such as diesel fuel or gasoline, are not to be used as ignition sources for the hood and duct.

**5.4.3.2** Ignition occurs when the temperature at the 3,6 m thermocouple reaches at least 871 °C or when the temperature at the 6,1 m thermocouple reaches at least 649 °C, whichever occurs first. In general, the 3,6 m thermocouple reading fluctuates between 427 °C and 482 °C for a short while and then rises rapidly.

**5.4.3.3** When ignition occurs, the ignition sources are to be shut down. After all ignition sources have been shut down, and when the temperature at the 6,1 m thermocouple stabilizes above 482 °C or when it continues to increase, a 30 s countdown is to be started. The 30 s countdown is not to be started while the temperature is dropping after the shutting down of the ignition sources. The countdown is to be halted whenever the temperature starts to drop and is to be resumed when the temperature at the 6,1 m thermocouple stabilized above 482 °C or when it begins to rise above 482 °C.

**5.4.3.4** At the conclusion of the 30 s countdown, the extinguishing system unit is to be manually operated.

### 5.4.4 Plenum testing

**5.4.4.1** In addition to the tests specified in [5.4.2](#) to [5.4.3](#), a plenum test is to be conducted with the ignition occurring when the plenum and the filter fire is at its maximum intensity, as determined by visual observation. At the point of maximum intensity, the system is to be manually activated. Small residual flames shall self-extinguish. For the plenum test, the duct outlet is to be open and the blower assistance as specified in [5.4.2.6 c\)](#) is to be used.

**5.4.4.2** Prior to conducting the extinguishing test, discharge tests are to be conducted in the plenum area, using the air flows specified in [5.4.2.6 a\)](#) and [c\)](#) to verify the extinguishing agent is capable of covering the filter area.

### 5.4.5 Conditions of acceptability

**5.4.5.1** Upon actuation, the fire shall be extinguished, as evidenced by the sharp decrease in temperature, and in no instance shall an increase in temperature occur. Routine fluctuations in recording instruments are to be disregarded. Small residual flames shall self-extinguish with no additional application of extinguishing agent.

**5.4.5.2** The duct and hood are then to be examined after the fire has been extinguished. For successful test results, grease shall be present in the system to the extent that the grease would have been able to sustain the fire had it not been extinguished.

## 6 Installation, operation and maintenance instruction manual

**6.1** As required by [4.3.1](#), a copy of the installation, operating, recharging, inspection and maintenance instruction manual is to be furnished for use as a reference in the examination and testing of an automatic extinguishing unit or pre-engineered extinguishing system unit.

**6.2** The instructions shall reference the limitations of each extinguishing system unit and shall include at least the following items:

- a) description and operating details of each extinguishing system unit and all accessory equipment, including identification of extinguishing system units or accessory equipment by part number or model;
- b) type of protection afforded by the system;
- c) type of pipe, hose, tubing and fittings to be used;
- d) typical system layout and specific limitations for correct system installation and effective protection, e.g. tilt skillet/braising pan instructions shall indicate that the nozzle is to be placed toward the front of the appliance to minimize potential interference to the nozzle discharge from, for example, a skillet cover;
- e) specific information on piping limitations for correct system installation and effective protection;
- f) description of all variations of each extinguishing system, including the limitations for each variation;
- g) discharge nozzle limitations, including maximum dimensional and area coverage for each different appliance, minimum and maximum height limitations, and nozzle location(s). When a system unit is limited to a maximum volume, this information shall also be included;
- h) installation details of each extinguishing system unit, including accessory equipment;
- i) reference to the specific types of detection and control panels (where applicable) to be connected to the equipment;
- j) specifications and instructions for the interconnection of multiple extinguishing system units, or a caution statement to not use multiples of units, when a means for interconnecting is unavailable;
- k) operating pressure of the system at 21 °C;
- l) operating temperature range limitations;
- m) information on inspection of system after installation;
- n) instructions intended for use by a person trained to carry out the system's annual inspection, which includes
  - 1) an inspection to see that the hazards have not changed,
  - 2) an examination of all detectors, the expellant gas container(s), the agent container(s), actuation devices, hoses, nozzles, signals and all auxiliary equipment, including the shutdown devices,
  - 3) an inspection of the quality and level of the extinguishing agent,
  - 4) a verification that the agent distribution piping is not damaged and not obstructed,
  - 5) hydrostatic testing in accordance with the recommendations of the manufacturer or the approval agency,
  - 6) operation of the detection systems, signals, and releasing devices, including the manual stations and other associated equipment,
  - 7) corrective actions, repairs and replacement of defective or damaged parts,
  - 8) a maintenance report listing repairs and recommendations,
  - 9) obligatory replacement (at least annually from the date of installation) of fixed temperature sensing elements of the fusible metal alloy type (the old sensing elements shall be destroyed when removed),



- 10) replacement of temperature sensing elements, other than the fusible metal alloy type, which are permitted to remain in service provided they are inspected, cleaned or replaced if necessary in accordance with the manufacturer's instructions,
  - 11) obligatory recharging of all extinguishing system units after use or as indicated by the inspection and maintenance procedure, and
  - 12) obligatory discarding of any agent removed from the storage containers;
- o) detailed instructions for recharging the system after operation that shall:
- 1) contain
    - i) required instructions, warnings and cautions,
    - ii) a description of servicing equipment, and
    - iii) a description of procedures for intended servicing;
  - 2) provide a list of part numbers for all replacement parts;
  - 3) indicate that
    - i) the pressure gauge attached to the extinguishing system should not be used to determine when the intended charging pressure has been reached, and
    - ii) a pressure regulator should be used when the pressure source is a tank of high pressure gas, that is, gas at higher pressure than the charging pressure of the unit;
- p) description of the requirements for maintenance of all equipment;
- q) the name of the manufacturer or private labeller, or equivalent designation;
- r) date and manual designation on each page;
- s) material information, "safety data sheets" and cautionary instructions.

**6.3** An installation, operation and maintenance manual shall either be provided with each extinguishing system unit or made available upon request. When these manuals are not included with each system, an owner's manual shall be shipped with each system.

## 7 Owner's manual

**7.1** An owner's manual provided with an extinguishing system unit, in accordance with [6.3](#), shall include at least the following:

- a) clear indication that it is not to be recognized as a detailed installation, operation and maintenance manual;
- b) clear reference to the fact that the installation, operation and maintenance manual can be obtained by contacting the manufacturer;
- c) a statement that the system shall be inspected at least annually by qualified and trained personnel;
- d) information regarding procedures required to maintain the system in operation both before and after a fire;
- e) requirement for monthly inspections by owner to verify
  - proper location,
  - the actuators are not obstructed,

- the tamper seals (if provided) are intact,
  - no obvious physical damage or other condition exists to prevent operation,
  - the pressure gauges (if provided) are in the operable range,
  - the nozzles are in the proper place, undamaged and with the blow-off caps in place, and
  - the appliances have not been moved;
- f) a statement that no modifications are to be made to the system without consulting a qualified and trained system designer who refers to the detailed installation or maintenance manual. The statement shall include the following or equivalent wording:

“This system is made of units tested within limitations contained in the detailed installation manual. The system designer must be consulted whenever changes are planned for the system or area of protection. An authorized installer or system designer must be consulted after the system has discharged.”

## 8 Test report

**8.1** The test report shall be as comprehensive as possible and shall include any observations made during the test and comments on any difficulties experienced during the test. The units for all measurements shall be clearly stated in the report.

**8.2** The following essential information, as applicable, shall be given in the test report:

- a) the name and address of the test laboratory;
- b) the name and address of the sponsor;
- c) the name and address of the manufacturer/supplier of the extinguishing system tested;
- d) a copy of the manufacturer’s installation, operation, and maintenance instruction manual;
- e) a copy of the owner’s manual;
- f) for each test:
  - 1) the date(s) of the test;
  - 2) the operator(s) who carried out the test;
  - 3) the trade name and identification code for the products and components;
  - 4) the type, dimensions, and precise details of the equipment used (e.g. the deep fat fryer), including the maximum size of equipment tested;
  - 5) the details on the pipe and fittings used for each test;
  - 6) the discharge rate of the extinguishing agent during the test in kg/s;
  - 7) the amount of agent used in each test;
  - 8) the nozzle type, location, and height;
  - 9) the discharge pressure of the agent during the test, in MPa;
  - 10) the discharge temperature of the agent container and the cartridge (if applicable) used during the test, in °C;
- g) any observations and any classification corresponding to the equipment tested;

h) any other comments and observations concerning the testing.





# British Standards Institution (BSI)

BSI is the national body responsible for preparing British Standards and other standards-related publications, information and services.

BSI is incorporated by Royal Charter. British Standards and other standardization products are published by BSI Standards Limited.

## About us

We bring together business, industry, government, consumers, innovators and others to shape their combined experience and expertise into standards-based solutions.

The knowledge embodied in our standards has been carefully assembled in a dependable format and refined through our open consultation process. Organizations of all sizes and across all sectors choose standards to help them achieve their goals.

## Information on standards

We can provide you with the knowledge that your organization needs to succeed. Find out more about British Standards by visiting our website at [bsigroup.com/standards](http://bsigroup.com/standards) or contacting our Customer Services team or Knowledge Centre.

## Buying standards

You can buy and download PDF versions of BSI publications, including British and adopted European and international standards, through our website at [bsigroup.com/shop](http://bsigroup.com/shop), where hard copies can also be purchased.

If you need international and foreign standards from other Standards Development Organizations, hard copies can be ordered from our Customer Services team.

## Subscriptions

Our range of subscription services are designed to make using standards easier for you. For further information on our subscription products go to [bsigroup.com/subscriptions](http://bsigroup.com/subscriptions).

With **British Standards Online (BSOL)** you'll have instant access to over 55,000 British and adopted European and international standards from your desktop. It's available 24/7 and is refreshed daily so you'll always be up to date.

You can keep in touch with standards developments and receive substantial discounts on the purchase price of standards, both in single copy and subscription format, by becoming a **BSI Subscribing Member**.

**PLUS** is an updating service exclusive to BSI Subscribing Members. You will automatically receive the latest hard copy of your standards when they're revised or replaced.

To find out more about becoming a BSI Subscribing Member and the benefits of membership, please visit [bsigroup.com/shop](http://bsigroup.com/shop).

With a **Multi-User Network Licence (MUNL)** you are able to host standards publications on your intranet. Licences can cover as few or as many users as you wish. With updates supplied as soon as they're available, you can be sure your documentation is current. For further information, email [bsmusales@bsigroup.com](mailto:bsmusales@bsigroup.com).

## BSI Group Headquarters

389 Chiswick High Road London W4 4AL UK

## Revisions

Our British Standards and other publications are updated by amendment or revision.

We continually improve the quality of our products and services to benefit your business. If you find an inaccuracy or ambiguity within a British Standard or other BSI publication please inform the Knowledge Centre.

## Copyright

All the data, software and documentation set out in all British Standards and other BSI publications are the property of and copyrighted by BSI, or some person or entity that owns copyright in the information used (such as the international standardization bodies) and has formally licensed such information to BSI for commercial publication and use. Except as permitted under the Copyright, Designs and Patents Act 1988 no extract may be reproduced, stored in a retrieval system or transmitted in any form or by any means – electronic, photocopying, recording or otherwise – without prior written permission from BSI. Details and advice can be obtained from the Copyright & Licensing Department.

## Useful Contacts:

### Customer Services

**Tel:** +44 845 086 9001

**Email (orders):** [orders@bsigroup.com](mailto:orders@bsigroup.com)

**Email (enquiries):** [cservices@bsigroup.com](mailto:cservices@bsigroup.com)

### Subscriptions

**Tel:** +44 845 086 9001

**Email:** [subscriptions@bsigroup.com](mailto:subscriptions@bsigroup.com)

### Knowledge Centre

**Tel:** +44 20 8996 7004

**Email:** [knowledgecentre@bsigroup.com](mailto:knowledgecentre@bsigroup.com)

### Copyright & Licensing

**Tel:** +44 20 8996 7070

**Email:** [copyright@bsigroup.com](mailto:copyright@bsigroup.com)



...making excellence a habit.™