



BSI Standards Publication

# **Nuclear fuel technology — Chemical separation and purification of uranium and plutonium in nitric acid solutions for isotopic and isotopic dilution analysis by solvent extraction chromatography**

Part 1: Samples containing plutonium in the microgram range and uranium in the milligram range

**National foreword**

This British Standard is the UK implementation of ISO 15366-1:2014.

The UK participation in its preparation was entrusted to Technical Committee NCE/9, Nuclear fuel cycle technology.

A list of organizations represented on this committee can be obtained on request to its secretary.

This publication does not purport to include all the necessary provisions of a contract. Users are responsible for its correct application.

© The British Standards Institution 2014. Published by BSI Standards Limited 2014

ISBN 978 0 580 74489 1

ICS 27.120.30

**Compliance with a British Standard cannot confer immunity from legal obligations.**

This British Standard was published under the authority of the Standards Policy and Strategy Committee on 30 June 2014.

**Amendments issued since publication**

Date	Text affected
------	---------------

---

---

---

**Nuclear fuel technology — Chemical separation and purification of uranium and plutonium in nitric acid solutions for isotopic and isotopic dilution analysis by solvent extraction chromatography —**

**Part 1:  
Samples containing plutonium in the microgram range and uranium in the milligram range**

*Technologie du combustible nucléaire — Séparation et purification chimiques de l'uranium et du plutonium dans les solutions d'acide nitrique par extraction chromatographique par solvant pour les mesures isotopiques et les analyses par dilution isotopique —*

*Partie 1: Échantillons ayant des teneurs en plutonium de l'ordre du microgramme et en uranium de l'ordre du milligramme*





**COPYRIGHT PROTECTED DOCUMENT**

© ISO 2014

All rights reserved. Unless otherwise specified, no part of this publication may be reproduced or utilized otherwise in any form or by any means, electronic or mechanical, including photocopying, or posting on the internet or an intranet, without prior written permission. Permission can be requested from either ISO at the address below or ISO's member body in the country of the requester.

ISO copyright office  
Case postale 56 • CH-1211 Geneva 20  
Tel. + 41 22 749 01 11  
Fax + 41 22 749 09 47  
E-mail [copyright@iso.org](mailto:copyright@iso.org)  
Web [www.iso.org](http://www.iso.org)

Published in Switzerland

# Contents

	Page
Foreword .....	iv
<b>1 Scope .....</b>	<b>1</b>
<b>2 Principle of the method .....</b>	<b>1</b>
<b>3 Apparatus .....</b>	<b>1</b>
<b>4 Reagents .....</b>	<b>2</b>
<b>5 Procedure (see <a href="#">Figure 1</a>) .....</b>	<b>2</b>
<b>6 Characteristics of the separation .....</b>	<b>4</b>
<b>7 Quality control .....</b>	<b>5</b>
<b>8 Interferences .....</b>	<b>5</b>
<b>Annex A (normative) Packing and conditioning of the chromatographic columns as used in the ISO 15366 1 procedure, loaded with an inert silica support coated with tri-n-octyl- phosphine-oxide (TOPO) .....</b>	<b>7</b>
<b>Bibliography .....</b>	<b>10</b>

## Foreword

ISO (the International Organization for Standardization) is a worldwide federation of national standards bodies (ISO member bodies). The work of preparing International Standards is normally carried out through ISO technical committees. Each member body interested in a subject for which a technical committee has been established has the right to be represented on that committee. International organizations, governmental and non-governmental, in liaison with ISO, also take part in the work. ISO collaborates closely with the International Electrotechnical Commission (IEC) on all matters of electrotechnical standardization.

The procedures used to develop this document and those intended for its further maintenance are described in the ISO/IEC Directives, Part 1. In particular the different approval criteria needed for the different types of ISO documents should be noted. This document was drafted in accordance with the editorial rules of the ISO/IEC Directives, Part 2. [www.iso.org/directives](http://www.iso.org/directives)

Attention is drawn to the possibility that some of the elements of this document may be the subject of patent rights. ISO shall not be held responsible for identifying any or all such patent rights. Details of any patent rights identified during the development of the document will be in the Introduction and/or on the ISO list of patent declarations received. [www.iso.org/patents](http://www.iso.org/patents)

Any trade name used in this document is information given for the convenience of users and does not constitute an endorsement.

For an explanation on the meaning of ISO specific terms and expressions related to conformity assessment, as well as information about ISO's adherence to the WTO principles in the Technical Barriers to Trade (TBT) see the following URL: [Foreword - Supplementary information](#)

The committee responsible for this document is ISO/TC 85, *Nuclear energy, nuclear technologies, and radiological protection*, Subcommittee SC 5, *Nuclear fuel cycle*.

This first edition, together with the first edition of ISO 15366-2, cancels and replaces the first edition of ISO 15366:1999, which has been technically revised.

ISO 15366 consists of the following parts, under the general title *Chemical separation and purification of uranium and plutonium in nitric acid solutions for isotopic and isotopic dilution analysis by solvent extraction chromatography* —

- *Part 1: Sample containing plutonium in the microgram range and uranium in the milligram range*
- *Part 2: Sample containing plutonium and uranium amounts in the nanogram range and below*

# Nuclear fuel technology — Chemical separation and purification of uranium and plutonium in nitric acid solutions for isotopic and isotopic dilution analysis by solvent extraction chromatography —

## Part 1:

## Samples containing plutonium in the microgram range and uranium in the milligram range

### 1 Scope

This part of ISO 15366 describes procedures to chemically separate and purify uranium and plutonium in dissolved solutions of irradiated light water reactor fuels and in samples of high active liquid waste of spent fuel reprocessing plants, prior to their isotopic analysis by e.g. mass spectrometric method (see ISO 8299[1]) or alpha spectrometry (see ISO 11483[2]).

This part of ISO 15366, describes a technique for the separation of uranium and plutonium in spent fuel type samples based on chromatographic method. The procedure applies to samples containing 1 µg to 150 µg Pu (IV) and (VI) and 0,1 mg to 2 mg U (IV) and (VI) in up to 2 ml of 3 mol·l<sup>-1</sup> nitric acid solution. It is applicable to mixtures of uranium and plutonium in which the U/Pu-ratio can range from 0 up to 200.

### 2 Principle of the method

The chemical separation is based on a column extraction chromatography using tri-*n*-octylphosphine-oxide (TOPO) as extractant.[3][4] The necessary valency adjustment prior to the separation is done with iron(II) sulfate and sodium nitrite. The extraction process is performed in disposable columns loaded with a silica gel powder coated with the TOPO.[5] Plutonium(IV) and uranium(VI) in 3 mol·l<sup>-1</sup> nitric acid medium are selectively extracted into the TOPO while americium, the fission products and other interfering elements are not retained. Plutonium is eluted after reduction to the trivalent state with ascorbic acid[6]; uranium is eluted by an ammonium carbamate solution. Besides the measurement by mass spectrometry, the plutonium fractions are also measured by alpha spectrometry for the determination of the isotopic abundance of <sup>238</sup>Pu (mass spectrometry might be biased by residual amounts of uranium in the plutonium fraction) and for checking the recovery of plutonium.

In order to ensure favourable kinetics of the chemical reactions, the (gravity) column flow rates should not exceed 0,1 ml·min<sup>-1</sup>.

Parallel measurement of blank and/or control sample is recommended to verify the analysis.

Blanks are run in parallel with the samples to verify the absence of significant external cross-contamination and cross-contamination between samples.

Control samples prepared from certified or analysed materials are also prepared and separated along with the sample to verify that suitable valency adjustment, isotopic equilibration and separation efficiency are achieved.

### 3 Apparatus

**3.1 Biological shielding**, e.g. shielded glove box or fume cupboard.

**3.2 Disposable polypropylene or glass columns**, of length 90 mm, funnel reservoir 9,5 ml, support bed volume 1,4 ml, height of bed 26 mm, inner diameter of bed reservoir 8,4 mm. Frits of polyethylene or glass 20  $\mu\text{m}$  respectively 70  $\mu\text{m}$  porosity (See [Figure A.1](#)). Suitable polypropylene columns with polyethylene frits are available commercially and well adapted to robotized operation. The packing and conditioning of the columns are described in [Annex A](#). The chromatographic columns shall be disposed of in the radioactive waste after use.

**3.3 Two hot plates.**

**3.4 Standard laboratory equipment** (flasks and beakers, pipettes, glassware, stands and supports for columns, sample vials, fraction tubes, etc.).

**3.5 Glass vials.**

## 4 Reagents

Use only reagents of recognized analytical grade. All aqueous solutions shall be prepared with distilled or de-ionized water (resistivity 1  $\text{M}\Omega\cdot\text{m}$  to 10  $\text{M}\Omega\cdot\text{m}$ ).

**4.1 Concentrated nitric acid and nitric acid solutions**,  $c(\text{HNO}_3) = 6 \text{ mol}\cdot\text{l}^{-1}$  and  $3 \text{ mol}\cdot\text{l}^{-1}$ .

**4.2 Formic acid solution**,  $c(\text{HCOOH}) = 1 \text{ mol}\cdot\text{l}^{-1}$ .

**4.3 Ammonium carbamate** [CAS No. 1111-78-0] **solution**,  $c(\text{NH}_4\text{CO}_2\text{NH}_2) = 0,7 \text{ mol}\cdot\text{l}^{-1}$ .

**4.4 Silica gel 100**, 63  $\mu\text{m}$  to 200  $\mu\text{m}$ , prewashed with  $3 \text{ mol}\cdot\text{l}^{-1}$  nitric acid solution ([4.1](#)) and distilled or de-ionized water (see [A.3.1](#)).

**4.5 L(+)-Ascorbic acid solution**  $c(\text{C}_6\text{H}_8\text{O}_6) = 10^{-5} \text{ mol}\cdot\text{l}^{-1}$  or  $c(\text{C}_6\text{H}_8\text{O}_6) = 10^{-3} \text{ mol}\cdot\text{l}^{-1}$  in formic acid solution ([4.2](#))

**4.6 Tri-*n*-octylphosphine-oxide**,  $c(\text{TOPO}) = 0,2 \text{ mol}\cdot\text{l}^{-1}$  solution in cyclohexane.

**WARNING — This reagent is flammable and should always be handled in a well-ventilated place and never in the vicinity of a naked flame.**

**4.7 Iron(II) sulfate solution**,  $c(\text{FeSO}_4) = 0,1 \text{ mol}\cdot\text{l}^{-1}$  or  $c(\text{FeSO}_4) = 0,8 \text{ mol}\cdot\text{l}^{-1}$  in water. To be prepared freshly for each working session.

**4.8 Sodium nitrite solution**,  $c(\text{NaNO}_2) = 1 \text{ mol}\cdot\text{l}^{-1}$  or  $c(\text{NaNO}_2) = 5 \text{ mol}\cdot\text{l}^{-1}$  in water. To be prepared freshly for each working session.

## 5 Procedure (see [Figure 1](#))

**5.1** The sample should contain 1  $\mu\text{g}$  to 150  $\mu\text{g}$  plutonium and 0,1 mg to 2 mg uranium in a volume of 0,5 ml of  $3 \text{ mol}\cdot\text{l}^{-1}$  nitric acid solution ([4.1](#)). Whenever starting with dried samples, apply the following dissolution procedure.

- a) Add 0,5 ml of  $6 \text{ mol}\cdot\text{l}^{-1}$  nitric acid solution ([4.1](#)) to the dried samples and evaporate slowly on the hot plate, keeping the temperature slightly below the boiling point to avoid any splashing and bubbling until nitrate salts crystallize.

NOTE This procedure is an example. If equivalent results could be expected, other conditions than these described in [Clause 5](#), can be applied for sample preparation.



b) Remove the sample vessels from the hot plate and redissolve the salts by adding 0,5 ml of 3 mol·l<sup>-1</sup> nitric acid solution (4.1), while still warm (40 °C to 60 °C). Shake the vessels for a few seconds.

**5.2** Perform a redox valency cycle to ensure that all plutonium isotopes are in the tetravalent state before starting the separation, as follows.

- a) Add 50 µl of iron(II)-sulfate solution (4.7) to the sample.
- b) Mix and wait for 5 min for a complete reduction of plutonium(VI) or plutonium(IV) to plutonium(III).
- c) Add 50 µl sodium nitrite solution (4.8) to reoxidize plutonium to the tetravalent state and add further 100 µl of 6 mol·l<sup>-1</sup> nitric acid solution (4.1) to reach an acid concentration of 3 mol·l<sup>-1</sup>. Mix again and wait for at least 5 min.

**5.3** Transfer half of the pretreated sample on to the column, wait approximately 1 min, add the rest of the sample and let it flow through. This favours the retention of plutonium and uranium in the very upper layers of the column.

**5.4** Wash out the fission products, together with americium, from the column using 3 mol·l<sup>-1</sup> nitric acid solution (4.1) in 3 successive aliquots of 2, 3 and 4 ml.

**5.5** Condition the column for the plutonium elution by adding 2 ml of 1 mol·l<sup>-1</sup> formic acid solution (4.2). Discard waste collected up to this point.

**5.6** Elute the plutonium from the column with the ascorbic acid solution (4.5) with two successive aliquots of 3 ml. Place the vials containing the collected plutonium fractions on one of the hot plates.

**5.7** Wash out the “tail” of the plutonium with 4 ml of the ascorbic acid solution (4.5) in one aliquot and discard the plutonium “tail” washings to the waste.

**5.8** Condition the column for the elution of the uranium fraction by adding two aliquots each of 1 ml distilled water. Discard the water washings to the waste.

**5.9** Elute the uranium with 4 ml ammonium carbamate solution (4.3). Place the vials containing the collected uranium fractions on the other hot plate.

**5.10** Let the plutonium and uranium fractions evaporate gently to dryness on the hot plates at 90 °C.

**5.11** Remove the fractions from the hot plates, add 0,25 ml of concentrated nitric acid (4.1) and evaporate again to dryness. Repeat this step once.

**5.12** Redissolve the plutonium fractions, while the vials are still warm (40 °C to 60 °C), with a volume V(Pu) of nitric acid solution 3 mol·l<sup>-1</sup> (4.1) to obtain a Pu concentration of about 50 ng·µl<sup>-1</sup>.

Gently swirl the vial to facilitate the dissolution.

**5.13** Redissolve the uranium fractions, while the vials are still warm (40 °C to 60 °C), with a volume V(U) of nitric acid solution 3 mol·l<sup>-1</sup> (4.1) to obtain a U concentration of about 400 µg·ml<sup>-1</sup>.

Gently swirl the vial to facilitate the dissolution.

**5.14** Stopper the vials containing the plutonium and uranium fractions. Before submitting the plutonium fractions for mass spectrometric measurement ensure the proper plutonium concentration and the successful decontamination from americium by a rough check using gamma-spectrometry.

5.15 Forward all fractions for measurement by mass spectrometry and by alpha spectrometry.

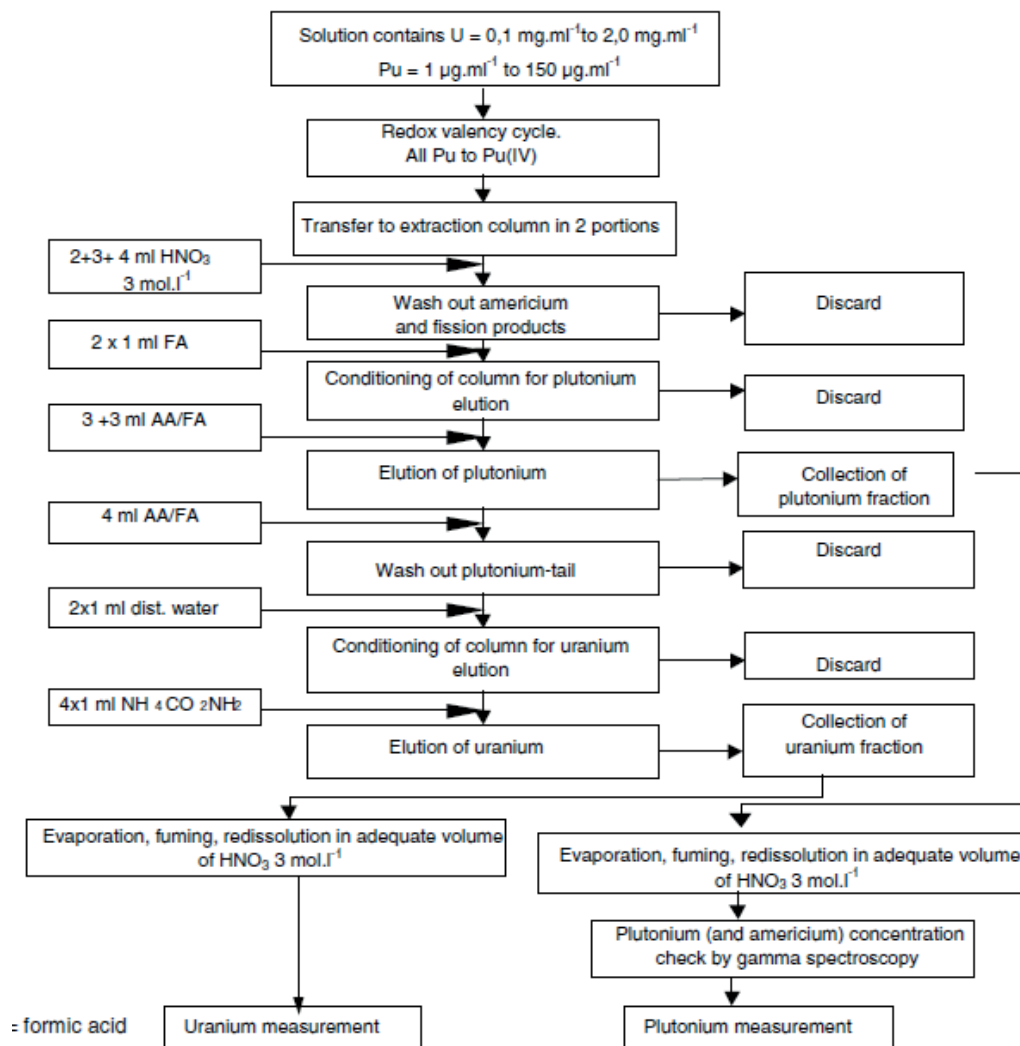

Figure 1 — U and Pu separation scheme

## 6 Characteristics of the separation

6.1 The element recovery varies between 80 % and 90 % for both uranium and plutonium in the range of 1 µg to 150 µg Pu and 0,1 mg to 2 mg U.

6.2 The separation procedure has no significant effect on the mass spectrometric measurement when compared to the measurement of pure unseparated uranium and plutonium reference materials, provided the working environment (blanks: see 6.1) is adequately controlled.

6.3 The column has the capacity to retain up to about 15 mg of uranium.

**6.4** The plutonium fractions contain less than a mass fraction of 0,001 % americium compared to total plutonium (a typical sample contains 0,3 µg to 0,4 µg <sup>241</sup>Am and 6 µg to 8 µg total plutonium).

**6.5** The plutonium fraction can be separated from uranium with a decontamination factor of the order of 10<sup>5</sup> or better.

**6.6** The uranium fraction can be separated from plutonium with a decontamination factor of the order of 10<sup>3</sup> or better.

**6.7** This method differs essentially from other U/Pu separation procedures (in particular ion exchange) in its robustness – the procedure may be interrupted and continued (e.g. over night) at almost any step.

## 7 Quality control

**7.1** Blanks: blank samples are spiked with known amounts of highly enriched tracers, such as <sup>242</sup>Pu and <sup>233</sup>U and processed in the same way as, and in parallel with the actual samples. The amounts of plutonium and uranium coming from the blank are determined by isotope dilution mass spectrometry according to ISO 8299.<sup>[1]</sup> The amounts of blank U and Pu should be monitored (in QC charts) and should usually remain well below 0,1 % relative to the amounts of the respective element in a typical sample.

**7.2** Control samples: solutions of plutonium and uranium nitrate of known isotopic and elemental composition, similar to the composition of the actual samples, are used to monitor the accuracy of the isotopic and elemental assays by alpha and mass spectrometry following the separation. Samples of such solutions are processed and measured in the same way as, and in parallel with the actual samples. The results of such control measurements are preferably followed with statistical control charts.

## 8 Interferences

**8.1** Extractable elements: according to Reference [3], only Ti(IV), Zr(IV), Hf(IV), Ge(IV), Sn(IV), Tc(VIII), Eu(III), Ce(IV), Th(IV), Np(IV) and Np(V) may be extracted from nitric acid, 3 mol·l<sup>-1</sup>, along with uranium and plutonium.

**8.2** Interferences in mass spectrometry measurements according to ISO 8299<sup>[1]</sup>: elements yielding ions with mass 233, 234, 235, 236 and 238 cause interference in the mass spectrometric analysis of uranium if they have not been removed, or if they have been introduced as impurities during the chemical treatment; potassium for example will emit hexa-atomic ions of mass 234.

Elements yielding ions with mass 238 (particularly <sup>238</sup>U), 239, 240, 241 and 242 cause interference in the mass spectrometric analysis of plutonium if they have not been completely removed during chemical treatment.

In addition to the isobaric interferences, another class of interfering elements can alter the fractionation patterns in mass spectrometric analyses. For example, thorium, zirconium, hafnium, rare earth metals, aluminium, and titanium can increase the temperature required to volatilize and ionize uranium and plutonium. Iron, vanadium, copper and alkali metals can lower the temperature at which volatilization of uranium and plutonium occurs. Among these, only Th, Zr, Hf and Ti may be retained by TOPO from nitric acid, 3 mol·l<sup>-1</sup>.

**8.3** Interferences in alpha spectrometry measurements according to ISO 11483<sup>[2]</sup>: the nuclide <sup>241</sup>Am emits alpha particles of energies very close to the energies of the radiation emitted by the nuclide <sup>238</sup>Pu. Its presence yields positive biases in the determination of the <sup>238</sup>Pu abundance by alpha spectrometry. In the case of a five year old plutonium sample, containing 1 % of the <sup>238</sup>Pu isotope, 10 % of the <sup>241</sup>Pu isotope and 2,7 % of the <sup>241</sup>Am isotope, the relative bias is equal to 0,06 % immediately after separation, if the americium decontamination factor is 10<sup>3</sup>. An additional bias of 0,027 % accumulates every day following the separation. The efficiency of the <sup>241</sup>Am-decontamination should be checked regularly by

gamma spectrometry or by repeating the alpha spectrometry after submitting the plutonium fraction to a second separation. The alpha spectrometry should be done within one week after the separation is completed.

Nuclides emitting alpha particles of energies between 4,9 MeV and 5,6 MeV can interfere in the alpha spectrometric analysis if they are not separated during the purification of plutonium.

Any chemical compound, which is not completely eliminated during the chemical separation or during the preparation of the source, decreases the quality of the source and the resolution of the alpha spectra. Even if these compounds are not radioactive, the errors in the processing of the spectra become significant when the half height width of the peaks become greater than 25 keV. Silicon compounds which might leach out of the column shall be removed by prewashing the column just before use as described in [A.3](#) and [A.5](#).

## Annex A (normative)

### Packing and conditioning of the chromatographic columns as used in the ISO 15366 1 procedure, loaded with an inert silica support coated with tri-*n*-octyl-phosphine-oxide (TOPO)

#### A.1 General

This annex is an integral part of the ISO 15366-1 procedure and describes the procedure for the preparation of the chromatographic columns.

The goal is to obtain an inert support uniformly coated with tri-*n*-octyl-phosphine-oxide and its homogeneous packing into the column, ensuring that the flow of the effluents is reproducible and uniform during the separation process.

#### A.2 Apparatus

The column shall be prepared in a clean area where contamination by actinides can be excluded.

**A.2.1 Columns and frits** (see [Figure A.1](#)).

**A.2.2 Dispensing spoon** (PVC) to measure 0,25 g of the TOPO/silica gel powder).

**A.2.3 Rubber bulb.**

**A.2.4 Shaker with column holder.** A custom-built plastic rack is mounted on a commercial "Vortex"-mixer.

**A.2.5 PVC rod**, 6 mm in diameter, 150 mm length, to push the frit into the column.

#### A.3 Coating the silica gel support with TOPO

The silica gel powder is coated with TOPO as follows to obtain a dry and loose powder:

**A.3.1** First wash the silica gel 100 in the following manner:

Weigh 40 g silica gel 100 into a beaker and wash with about 100 ml of nitric acid solution 3 mol·l<sup>-1</sup>([4.1](#)), swirling and mixing the slurry each 10 min for at least half an hour. Allow the slurry to set and discard the acid solution. Wash in a similar way the silica gel 100 with distilled water at least 10 times in order to obtain an acid free support. Dry the wet silica gel 100 on a big watch-glass overnight at 120 °C. Allow the powder to cool before further use.

**A.3.2** Weigh 30 g of the washed and dried silica gel into a 250 ml beaker.

**A.3.3** Place the beaker on the balance in a well-ventilated area and add swiftly 45 g of 0,2 mol·l<sup>-1</sup> solution of TOPO in cyclohexane.

**A.3.4** Stir steadily and quickly with a plastic spoon taking care that the silica gel is uniformly wetted and coated with the TOPO solution.

**A.3.5** Transfer the mixture to a large watch-glass or Petri dish, spread it evenly with the spoon and allow the material to dry. The cyclohexane evaporates rapidly leaving a dry silica gel coated with TOPO. Leave uncovered in a well ventilated room for 40 eight hours, at room temperature to reach complete dryness.

Never dry above room temperature. Drying at higher temperatures will produce crusty clumps and the TOPO will tend to flake away from the surface of the silica gel particles.

**A.3.6** Store the powder in plastic bottles and use whenever needed.

## **A.4 Packing the columns**

The chromatographic columns are prepared, as follows, only for a single use and discarded to the radioactive waste after the performance of the separation.

**A.4.1** Sieve the TOPO/silica gel powder through a stainless steel sieve with 0,25 mm pores to ensure that no bulk TOPO is added to the column.

**A.4.2** Take a 20  $\mu\text{m}$  frit and place it in the column reservoir. Push the frit gently with the PVC rod down the column until it rests on the flat bottom of the column, without damaging or twisting the frit ([Figure A.1](#)).

**A.4.3** Bring the column on to the column holder of the shaker and introduce a glass-funnel into its upper reservoir.

**A.4.4** Fill the special dispensing plastic spoon with sieved TOPO/silica gel powder up to the rim and pour it through the funnel into the column. Remove the funnel from the column.

**A.4.5** Fill as many columns as needed, following steps [A.4.2](#) to [A.4.5](#).

**A.4.6** Set the shaker to 1 200  $\text{min}^{-1}$  and let the columns vibrate for about five seconds. This has the purpose of distributing homogeneously the TOPO/silica gel beads in the column. Half of the support material has been packed in the column at this time.

**A.4.7** The second half is added by repeating steps [4.4](#) to [4.6](#).

0,5 g TOPO/silica gel have been added to each column at this time.

**A.4.8** Take a 70  $\mu\text{m}$  frit and place it in the column reservoir on top of the bed of TOPO/silica gel. Push the frit carefully with the PVC rod until it presses gently on the TOPO/silica gel filling. Take care that the frit sits horizontally on the TOPO/silica gel (see [Figure A.1](#)).

**A.4.9** Store the column in a sealed plastic bag for later use, and condition it as described below before use.

## **A.5 Conditioning the columns**

Condition the columns immediately before use in a clean area, excluding contamination by actinides, and outside of the analytical glove box to avoid unnecessary production of radioactive waste, as follows:

**A.5.1** Bring the necessary number of columns into a clean area excluding the risk of contamination by actinides.

**A.5.2** Remove the columns from their storage bag and place them on a stand above a flat-bottomed dish.

**A.5.3** Add 8 ml of nitric acid solution  $3 \text{ mol}\cdot\text{l}^{-1}$  to the column and press the solution gently with a rubber bulb through the TOPO/silica gel until liquid drops appear at the column tip. At this time, the diluted acid will flow by gravity unattended until the reservoir is empty.

**A.5.4** When the reagent stops flowing and the reservoir is empty, transfer the column into the glove box and proceed with the separation.

Dimensions in millimetres

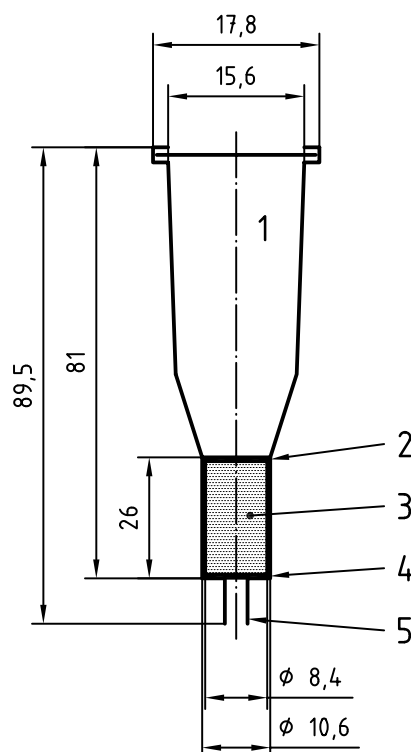

**Key**

- 1 reservoir, volume 9,5 ml
- 2 polyethylene frit, 70  $\mu\text{m}$  porosity
- 3 TOPO/silica gel, mass 500 mg, volume 1,4 ml
- 4 polyethylene frit, 20  $\mu\text{m}$  porosity
- 5 Luer tip

**Figure A.1 — Chromatographic column for separations**

## Bibliography

- [1] ISO 8299, *Nuclear fuel technology — Determination of the isotopic and elemental uranium and plutonium concentrations of nuclear materials in nitric acid solutions by thermal-ionization mass spectrometry*
- [2] ISO 11483, *Nuclear fuel technology — Preparation of plutonium sources and determination of  $^{238}\text{Pu}/^{239}\text{Pu}$  isotope ratio by alpha spectrometry*
- [3] WHITE J.C., & ROSS W.J. *Separations by Solvent Extraction with Tri-n-Octylphosphine Oxide*, NAS-NS 3102, National Academy of Sciences, Office of Technical Services, Department of Commerce, Washington 25, DC, USA, 1961-02-08
- [4] ZAHRADNIK P., DOUBEK N., SWIETLY H., BAGLIANO G. *A Column Exchange Chromatographic Procedure for the Automated Purification of analytical samples in Nuclear Spent Fuel Reprocessing and Plutonium Fuel Fabrication. IAEA/AL/069*. IAEA, Vienna, 1992
- [5] DELLE SITE A. et al. *A new Procedure for the Extraction Chromatography Separation of Safeguards Samples with tri-n-octylphosphine oxide*, IAEA/RL/119, IAEA, Vienna, May 1985
- [6] ZIEGLER H., & MAYER K. Development of an Optimized Method for Faster and more Reliable Automated U/Pu/Np Separations. *Radiochim. Acta*. 1999, **86** pp. 123–128









# British Standards Institution (BSI)

BSI is the national body responsible for preparing British Standards and other standards-related publications, information and services.

BSI is incorporated by Royal Charter. British Standards and other standardization products are published by BSI Standards Limited.

## About us

We bring together business, industry, government, consumers, innovators and others to shape their combined experience and expertise into standards-based solutions.

The knowledge embodied in our standards has been carefully assembled in a dependable format and refined through our open consultation process. Organizations of all sizes and across all sectors choose standards to help them achieve their goals.

## Information on standards

We can provide you with the knowledge that your organization needs to succeed. Find out more about British Standards by visiting our website at [bsigroup.com/standards](http://bsigroup.com/standards) or contacting our Customer Services team or Knowledge Centre.

## Buying standards

You can buy and download PDF versions of BSI publications, including British and adopted European and international standards, through our website at [bsigroup.com/shop](http://bsigroup.com/shop), where hard copies can also be purchased.

If you need international and foreign standards from other Standards Development Organizations, hard copies can be ordered from our Customer Services team.

## Subscriptions

Our range of subscription services are designed to make using standards easier for you. For further information on our subscription products go to [bsigroup.com/subscriptions](http://bsigroup.com/subscriptions).

With **British Standards Online (BSOL)** you'll have instant access to over 55,000 British and adopted European and international standards from your desktop. It's available 24/7 and is refreshed daily so you'll always be up to date.

You can keep in touch with standards developments and receive substantial discounts on the purchase price of standards, both in single copy and subscription format, by becoming a **BSI Subscribing Member**.

**PLUS** is an updating service exclusive to BSI Subscribing Members. You will automatically receive the latest hard copy of your standards when they're revised or replaced.

To find out more about becoming a BSI Subscribing Member and the benefits of membership, please visit [bsigroup.com/shop](http://bsigroup.com/shop).

With a **Multi-User Network Licence (MUNL)** you are able to host standards publications on your intranet. Licences can cover as few or as many users as you wish. With updates supplied as soon as they're available, you can be sure your documentation is current. For further information, email [bsmusales@bsigroup.com](mailto:bsmusales@bsigroup.com).

## BSI Group Headquarters

389 Chiswick High Road London W4 4AL UK

## Revisions

Our British Standards and other publications are updated by amendment or revision.

We continually improve the quality of our products and services to benefit your business. If you find an inaccuracy or ambiguity within a British Standard or other BSI publication please inform the Knowledge Centre.

## Copyright

All the data, software and documentation set out in all British Standards and other BSI publications are the property of and copyrighted by BSI, or some person or entity that owns copyright in the information used (such as the international standardization bodies) and has formally licensed such information to BSI for commercial publication and use. Except as permitted under the Copyright, Designs and Patents Act 1988 no extract may be reproduced, stored in a retrieval system or transmitted in any form or by any means – electronic, photocopying, recording or otherwise – without prior written permission from BSI. Details and advice can be obtained from the Copyright & Licensing Department.

## Useful Contacts:

### Customer Services

**Tel:** +44 845 086 9001

**Email (orders):** [orders@bsigroup.com](mailto:orders@bsigroup.com)

**Email (enquiries):** [cservices@bsigroup.com](mailto:cservices@bsigroup.com)

### Subscriptions

**Tel:** +44 845 086 9001

**Email:** [subscriptions@bsigroup.com](mailto:subscriptions@bsigroup.com)

### Knowledge Centre

**Tel:** +44 20 8996 7004

**Email:** [knowledgecentre@bsigroup.com](mailto:knowledgecentre@bsigroup.com)

### Copyright & Licensing

**Tel:** +44 20 8996 7070

**Email:** [copyright@bsigroup.com](mailto:copyright@bsigroup.com)



...making excellence a habit.™