



BSI Standards Publication

Metallic materials — Tube ring hydraulic pressure test

National foreword

This British Standard is the UK implementation of ISO 15363:2017.

The UK participation in its preparation was entrusted to Technical Committee ISE/101/2, Ductility testing.

A list of organizations represented on this committee can be obtained on request to its secretary.

This publication does not purport to include all the necessary provisions of a contract. Users are responsible for its correct application.

© The British Standards Institution 2017
Published by BSI Standards Limited 2017

ISBN 978 0 580 96327 8

ICS 77.040.10

Compliance with a British Standard cannot confer immunity from legal obligations.

This British Standard was published under the authority of the Standards Policy and Strategy Committee on 31 July 2017.

Amendments/corrigenda issued since publication

Date	Text affected
------	---------------

INTERNATIONAL
STANDARD

ISO
15363

Second edition
2017-07

**Metallic materials — Tube ring
hydraulic pressure test**

*Matériaux métalliques — Essai d'expansion hydraulique sur anneau
tubulaire*



Reference number
ISO 15363:2017(E)



COPYRIGHT PROTECTED DOCUMENT

© ISO 2017, Published in Switzerland

All rights reserved. Unless otherwise specified, no part of this publication may be reproduced or utilized otherwise in any form or by any means, electronic or mechanical, including photocopying, or posting on the internet or an intranet, without prior written permission. Permission can be requested from either ISO at the address below or ISO's member body in the country of the requester.

ISO copyright office
Ch. de Blandonnet 8 • CP 401
CH-1214 Vernier, Geneva, Switzerland
Tel. +41 22 749 01 11
Fax +41 22 749 09 47
copyright@iso.org
www.iso.org

Contents

Page

Foreword	iv
1 Scope	1
2 Symbols	1
3 Principle	1
4 Apparatus	2
5 Test ring	3
5.1 Shape and position	3
5.2 Determination of dimensions	4
6 Test procedure	5
7 Hoop strength evaluation	6
8 Test report	7
Annex A (informative) Proof and reduced section testing	8
Annex B (informative) Comparison of symbols and designations used for steel tubes	9

Foreword

ISO (the International Organization for Standardization) is a worldwide federation of national standards bodies (ISO member bodies). The work of preparing International Standards is normally carried out through ISO technical committees. Each member body interested in a subject for which a technical committee has been established has the right to be represented on that committee. International organizations, governmental and non-governmental, in liaison with ISO, also take part in the work. ISO collaborates closely with the International Electrotechnical Commission (IEC) on all matters of electrotechnical standardization.

The procedures used to develop this document and those intended for its further maintenance are described in the ISO/IEC Directives, Part 1. In particular the different approval criteria needed for the different types of ISO documents should be noted. This document was drafted in accordance with the editorial rules of the ISO/IEC Directives, Part 2 (see www.iso.org/directives).

Attention is drawn to the possibility that some of the elements of this document may be the subject of patent rights. ISO shall not be held responsible for identifying any or all such patent rights. Details of any patent rights identified during the development of the document will be in the Introduction and/or on the ISO list of patent declarations received (see www.iso.org/patents).

Any trade name used in this document is information given for the convenience of users and does not constitute an endorsement.

For an explanation on the voluntary nature of standards, the meaning of ISO specific terms and expressions related to conformity assessment, as well as information about ISO's adherence to the World Trade Organization (WTO) principles in the Technical Barriers to Trade (TBT) see the following URL: www.iso.org/iso/foreword.html

This document was prepared by Technical Committee ISO/TC 164, *Mechanical testing of metals*, Subcommittee SC 2, *Ductility testing*.

This second edition cancels and replaces the first edition (ISO 15363:2000), of which it constitutes a minor revision.

The main changes to the previous edition are:

- Addition of the comparison of symbols and designations used for steel tubes as Annex B for harmonizing EN 10275:1999.

[Annex A](#) and [Annex B](#) of this document are for information only.

Metallic materials — Tube ring hydraulic pressure test

1 Scope

This document specifies the ring hydraulic pressure test for metallic tubes. It is generally applied to tubes with an outside diameter greater than 120 mm and outside diameter to thickness ratio of not less than 20.

The objective of this test is to ascertain the value of the hoop stress required to produce a specified total circumferential (hoop) strain.

2 Symbols

Symbols and corresponding designations are given in [Table 1](#).

Table 1 — Symbols and designations

Symbol	Designation	Unit
a	Measured tube test ring thickness	mm
A_t	Specified total circumferential strain	%
d	Measured outside diameter of the tube test ring	mm
l	Length of tube test ring	mm
p	Hydrostatic pressure to produce the specified total circumferential strain	MPa
R_{At}	Hoop strength at the specified total strain	MPa
NOTE For symbols used in standards for steel tubes, please see Annex B .		

3 Principle

Unrestrained expansion of the test ring between two platens, under internal hydraulic pressure; the outer circumference of the tube is the effective test piece gauge length.

The test is carried out on a test piece taken from a welded or seamless tube of thickness up to a limit dependent upon the capacity of the machine and the strength of the tube (see [Figure 1](#)). All sharp edges are removed from product machined surfaces before testing. Where the hydraulic pressure required to produce the specified circumferential strain exceeds the capacity of the test machine, modified tests may be carried out as described in [Annex A](#).

The test is specified when a measure of the hoop strength is required which is not influenced by cold forming and residual stress introduced when flattening a standard tensile test piece. The standard tensile test is necessary, however, when tensile strength and elongation measurements are required.

Dimensions in millimetres

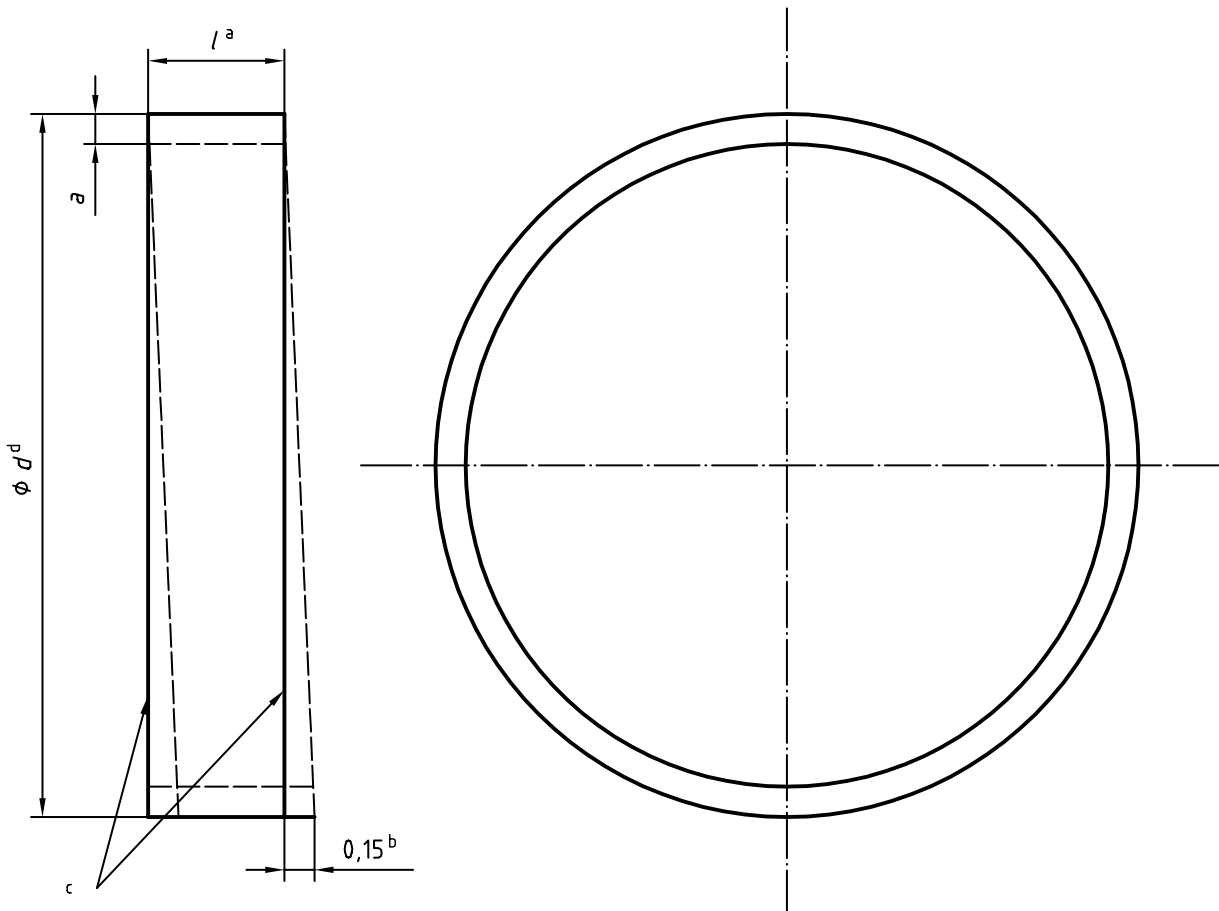

Key

- a Tolerance on l : $\pm 0,25$ mm; l is commonly taken as 76 mm.
- b Maximum deviation from normal.
- c Both faces to be machined parallel with fine turned or ground finish.
- d Measured outside diameter of the tube test ring.

Figure 1 — Test ring dimensions and tolerances

4 Apparatus

4.1 Testing machine, which shall be capable of allowing the test ring to expand freely without imposing any end restraint. This shall be achieved by leaving a small gap between the test piece and the top platen. Pressure loss during testing shall be prevented by the use of a flexible seal.

A typical testing machine is shown schematically in [Figure 2](#).

4.2 Platens. To reduce to a minimum any friction between the test piece, platens and inner die, the platens shall be parallel and have a fine turned or ground finish. Prior to each test, friction at the contact surfaces shall be further minimized either by the use of a lubricant, such as graphited grease, or by the use of PTFE (polytetrafluorethylene) sheet. The platens shall be inspected regularly and any ridges that develop shall be removed.

4.3 Test ring, to which stress shall be applied by means of a pressurized fluid. Provision shall be made to remove any air in the system through a bleed line.

WARNING — When carrying out the test, precautions should be taken for ensuring the safety of the operator.

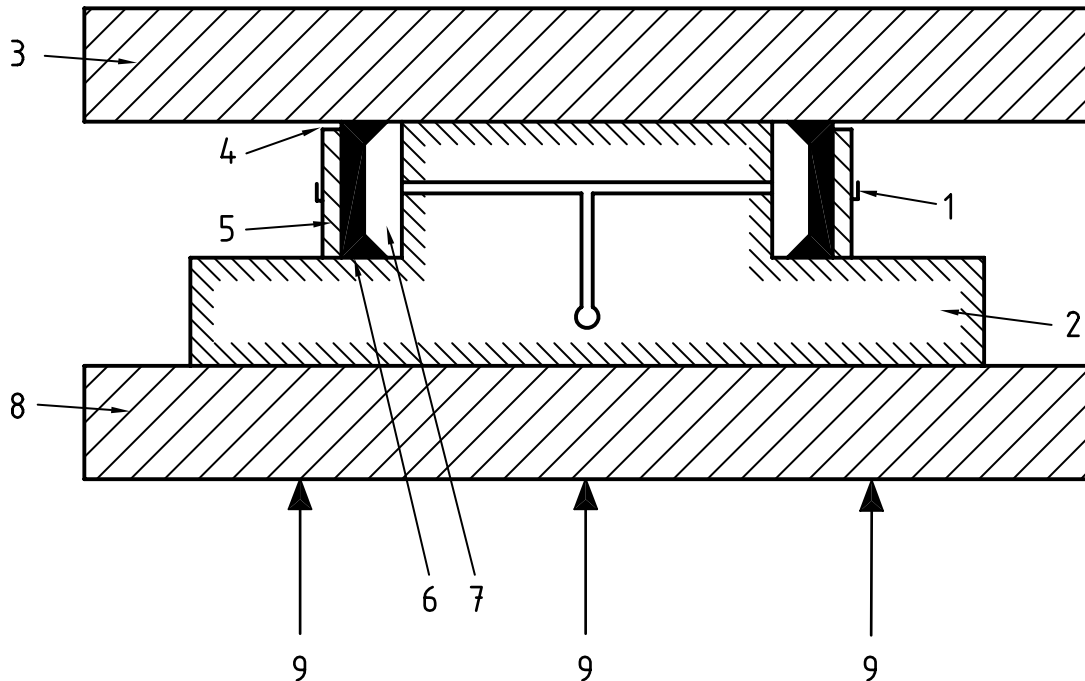

Key

- 1 circumferential measuring device, e.g. steel tape or roller chain
- 2 inner die
- 3 top platen
- 4 small gap
- 5 test ring
- 6 rubber seal or gasket
- 7 pressurizing fluid
- 8 bottom platen
- 9 clamping force

Figure 2 — Schematic diagram of testing machine (with installed test ring)

5 Test ring

5.1 Shape and position

5.1.1 Prior to separation from the main body of the tube, the test ring shall be marked with a unique identity.

5.1.2 The test ring may be prepared from an oversize flame cut sample. Final preparation shall be by a cold machining process to ensure removal of any heat affected zones. The machined edges shall have a fine turned or ground finish and be free from burrs.

5.1.3 The dimensions and tolerances for the test piece are given in [Figure 1](#). The machined edges shall be parallel and normal to the axis of the tube to within 0,15 mm measured across the diameter.

5.2 Determination of dimensions

5.2.1 The outside diameter of the test ring shall be calculated from measurement of the tube circumference, for example using a flexible steel tape. The maximum tolerance on the accuracy of this measurement shall be ± 1 mm.

5.2.2 The wall thickness shall be determined by calculating the mean of eight measurements taken at approximately 45° intervals around the test piece, excluding the weld region of welded tubes (see [Figure 3](#)). The measuring device shall be capable of measuring thickness to an accuracy greater than $\pm 0,025$ mm.

5.2.3 All tube diameter and thickness measurements of the test ring shall be fully documented.

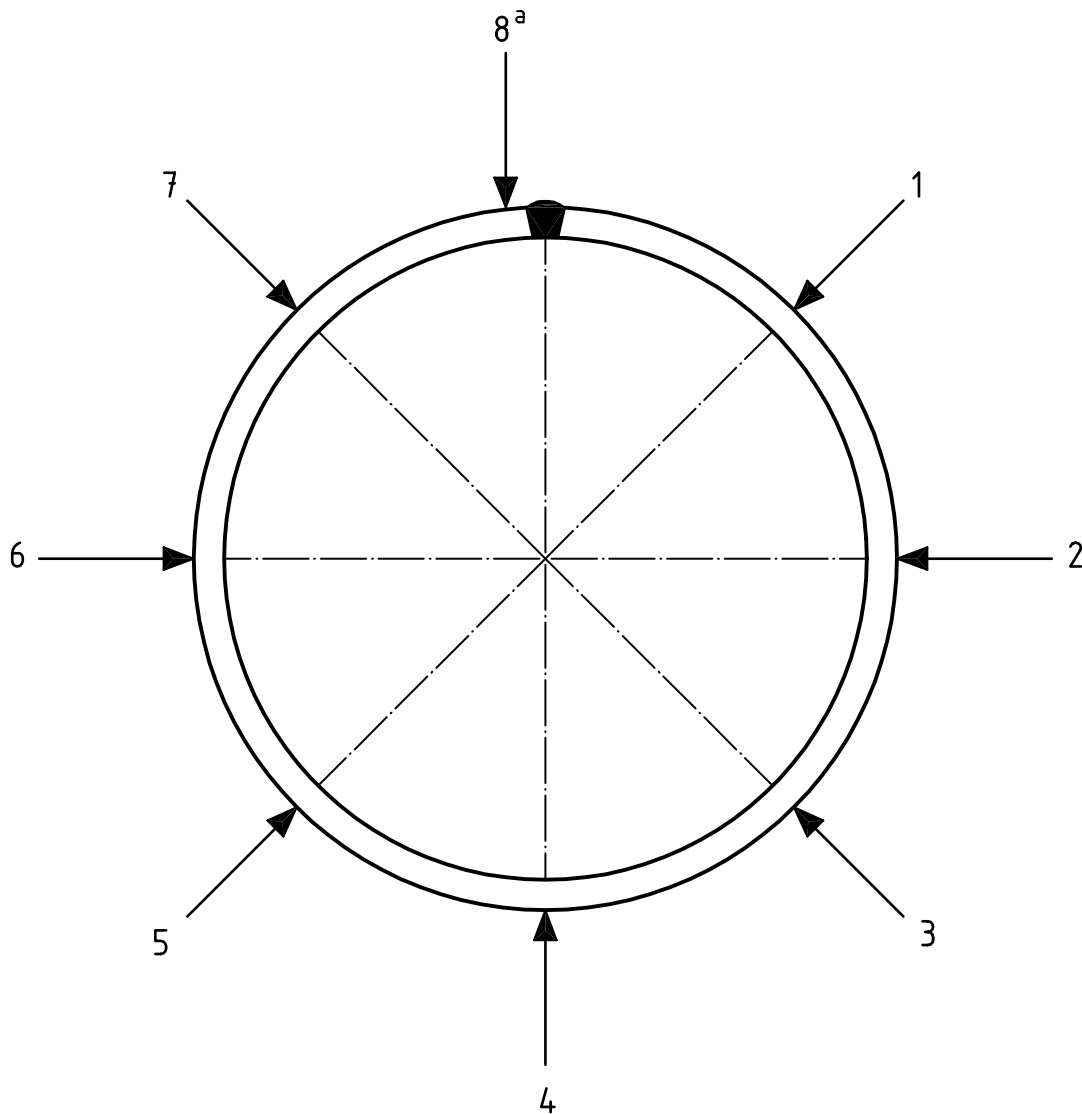

Key

^a Adjacent to the weld.

Figure 3 — Wall thickness measurement positions

6 Test procedure

6.1 The test procedure consists of applying pressure and measuring circumferential extension.

6.2 Circumferential extension of the test ring shall be measured during pressurization as follows.

The equipment for measuring the change of circumference, for example steel tape or roller chain extensometer, shall be wrapped around the test ring perimeter at the mid-point, crossing at the weld.

An example of the use of a steel tape is shown in [Figure 4](#). The separation between the two parallel portions of the measuring device shall be between 1,5 mm and 3 mm.

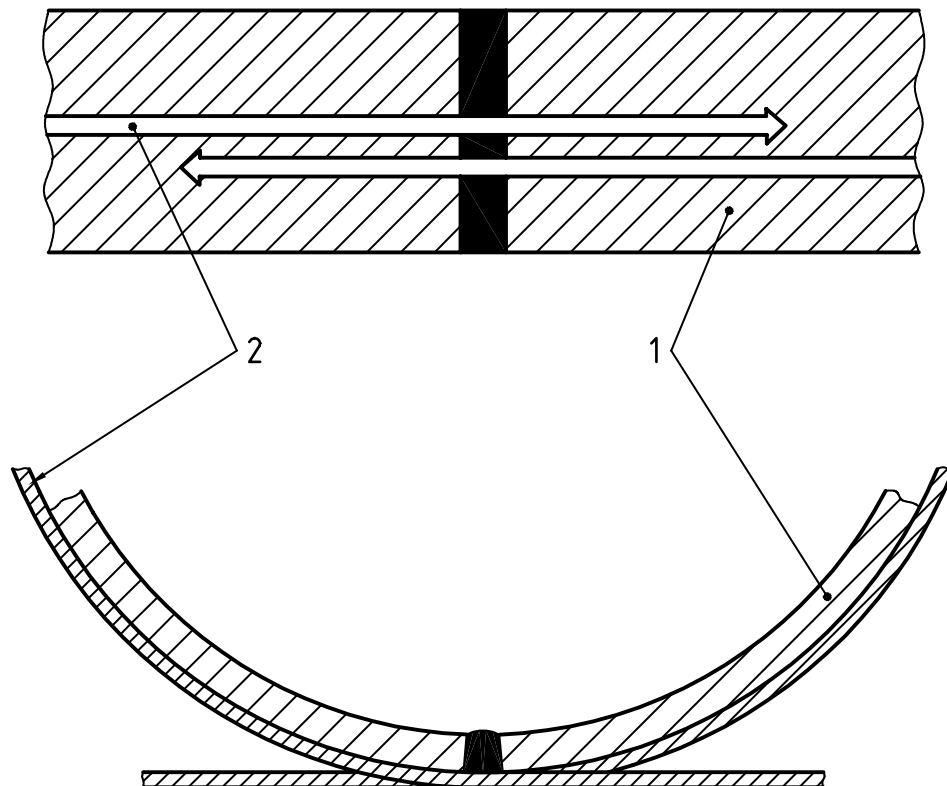

Key

- 1 tube under test
- 2 measuring device, e.g. steel tape

Figure 4 — Measuring device position for extension measurement

When a steel tape is used, friction shall be minimized by coating both the tape and test ring circumference with a suitable lubricant. Change in circumference shall be measured by a suitable mechanical or electrical device accurate to within $\pm 0,25$ mm.

6.3 The equipment for measuring the increase in circumference shall be wrapped around the test ring before application of the internal pressure.

6.4 The tolerance for the measurement of internal pressure shall be within ± 1 %. Accuracy of the pressure measurement device shall be verified, for example by comparison with dead weight test equipment, at the commencement of a sequence of testing and not less than once per year during the testing period.

6.5 The rate of strain shall not exceed 0,2 % min⁻¹.

6.6 The pressure and circumferential extension output signals shall be recorded, for example on an X-Y plotter, and related to the test piece identity.

7 Hoop strength evaluation

7.1 A typical test pressure-circumferential extension record is shown in [Figure 5](#).

7.2 The pressure p corresponding to the specified total circumferential strain shall be determined from the test record.

7.3 For tubes where $d/a \geq 20$, the hoop strength at the specified total strain shall be calculated from the formula

$$R_{At} = \frac{pd}{2a}$$

For tubes with $d/a < 20$, the hoop strength calculated from this formula becomes increasingly inaccurate and quantitative results should be used with caution. Factors such as strain hardening could have a significant effect on the validity of the calculated strength.

NOTE The specified total circumferential strain is calculated from the circumferential extension divided by the original test ring circumference.

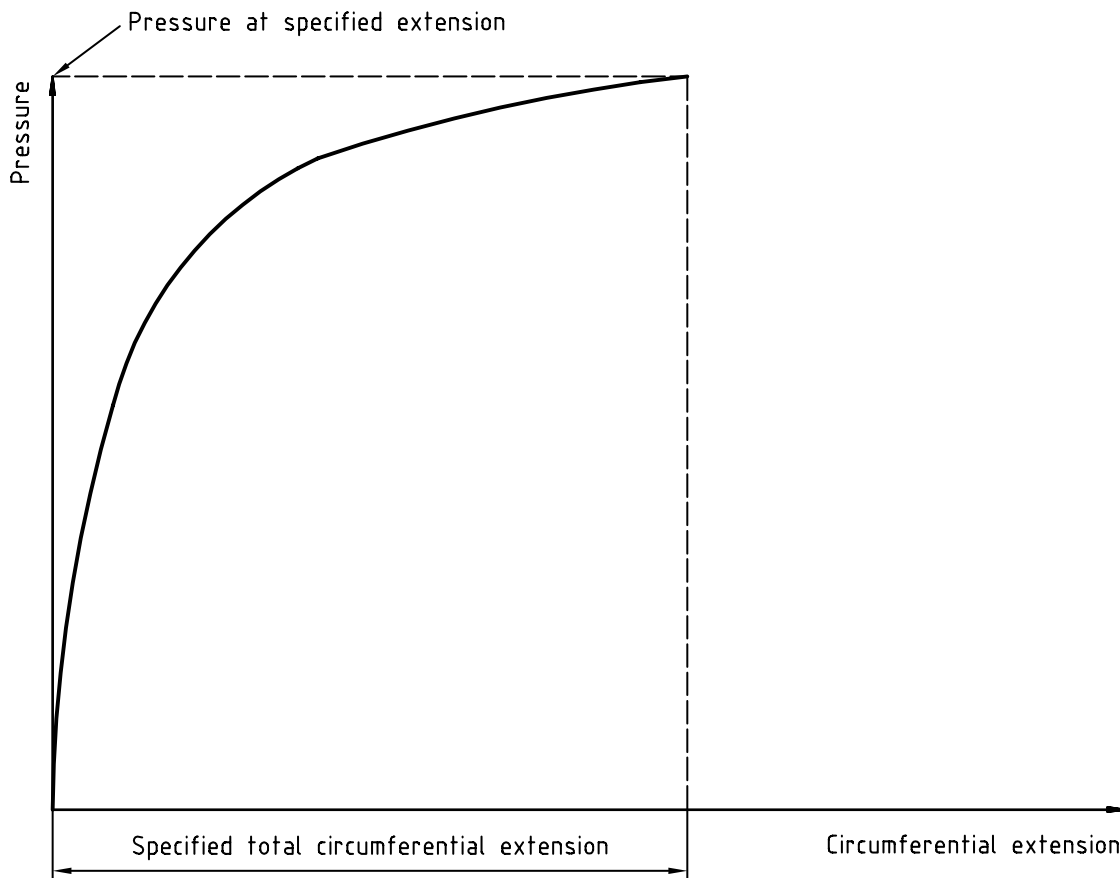

Figure 5 — Typical pressure/extension test record

8 Test report

The test report shall contain at least the following information:

- a) reference to this document, i.e. ISO 15363;
- b) identification of test ring, e.g. cast number/tube number /identification number;
- c) material specification, if known;
- d) diameter and wall thickness of the tube;
- e) length of the tube test ring;
- f) calculated hoop strength at specified total circumferential strain;
- g) reference to an alternative test method used, when appropriate (see [Annex A](#)).

Annex A **(informative)**

Proof and reduced section testing

A.1 Proof testing

This method may be used where the stress necessary to produce the specified circumferential extension has not been achieved, but where the stress in the test ring exceeds the specified minimum hoop strength requirement. In this case the percentage circumferential expansion achieved should be quoted in the report.

A.2 Reduced section testing

This method enables the stress corresponding to the specified circumferential extension to be achieved by a reduction in the test ring thickness. This reduction can be effected by machining the inside and/or outside of the tube. To ensure that the full thickness is represented, two or possibly three determinations should be carried out after machining:

- (i) inside;
- (ii) outside;
- (iii) both diameters.

Details of all test piece locations and dimensions relative to the full thickness ring section should be included in the report.

Annex B (informative)

Comparison of symbols and designations used for steel tubes

Table B.1 — Comparison of symbols and designations used for steel tubes

Symbol		Designation	Unit
a	T^a	Measured tube test ring thickness	mm
A_t	χ^a	Specified total circumferential strain	%
d	D^a	Measured outside diameter of the tube test ring	mm
l	L^a	Length of the tube test ring	mm
p	p^a	Hydrostatic pressure to produce the specified total circumferential strain	MPa
R_{At}	$R_{t\chi}^a$	Hoop strength at the specified total strain	MPa
^a These symbols are also used for these parameters in standards for steel tubes.			

British Standards Institution (BSI)

BSI is the national body responsible for preparing British Standards and other standards-related publications, information and services.

BSI is incorporated by Royal Charter. British Standards and other standardization products are published by BSI Standards Limited.

About us

We bring together business, industry, government, consumers, innovators and others to shape their combined experience and expertise into standards-based solutions.

The knowledge embodied in our standards has been carefully assembled in a dependable format and refined through our open consultation process. Organizations of all sizes and across all sectors choose standards to help them achieve their goals.

Information on standards

We can provide you with the knowledge that your organization needs to succeed. Find out more about British Standards by visiting our website at bsigroup.com/standards or contacting our Customer Services team or Knowledge Centre.

Buying standards

You can buy and download PDF versions of BSI publications, including British and adopted European and international standards, through our website at bsigroup.com/shop, where hard copies can also be purchased.

If you need international and foreign standards from other Standards Development Organizations, hard copies can be ordered from our Customer Services team.

Copyright in BSI publications

All the content in BSI publications, including British Standards, is the property of and copyrighted by BSI or some person or entity that owns copyright in the information used (such as the international standardization bodies) and has formally licensed such information to BSI for commercial publication and use.

Save for the provisions below, you may not transfer, share or disseminate any portion of the standard to any other person. You may not adapt, distribute, commercially exploit, or publicly display the standard or any portion thereof in any manner whatsoever without BSI's prior written consent.

Storing and using standards

Standards purchased in soft copy format:

- A British Standard purchased in soft copy format is licensed to a sole named user for personal or internal company use only.
- The standard may be stored on more than 1 device provided that it is accessible by the sole named user only and that only 1 copy is accessed at any one time.
- A single paper copy may be printed for personal or internal company use only.
- Standards purchased in hard copy format:
- A British Standard purchased in hard copy format is for personal or internal company use only.
- It may not be further reproduced – in any format – to create an additional copy. This includes scanning of the document.

If you need more than 1 copy of the document, or if you wish to share the document on an internal network, you can save money by choosing a subscription product (see 'Subscriptions').

Reproducing extracts

For permission to reproduce content from BSI publications contact the BSI Copyright & Licensing team.

Subscriptions

Our range of subscription services are designed to make using standards easier for you. For further information on our subscription products go to bsigroup.com/subscriptions.

With **British Standards Online (BSOL)** you'll have instant access to over 55,000 British and adopted European and international standards from your desktop. It's available 24/7 and is refreshed daily so you'll always be up to date.

You can keep in touch with standards developments and receive substantial discounts on the purchase price of standards, both in single copy and subscription format, by becoming a **BSI Subscribing Member**.

PLUS is an updating service exclusive to BSI Subscribing Members. You will automatically receive the latest hard copy of your standards when they're revised or replaced.

To find out more about becoming a BSI Subscribing Member and the benefits of membership, please visit bsigroup.com/shop.

With a **Multi-User Network Licence (MUNL)** you are able to host standards publications on your intranet. Licences can cover as few or as many users as you wish. With updates supplied as soon as they're available, you can be sure your documentation is current. For further information, email subscriptions@bsigroup.com.

Revisions

Our British Standards and other publications are updated by amendment or revision.

We continually improve the quality of our products and services to benefit your business. If you find an inaccuracy or ambiguity within a British Standard or other BSI publication please inform the Knowledge Centre.

Useful Contacts

Customer Services

Tel: +44 345 086 9001

Email (orders): orders@bsigroup.com

Email (enquiries): cservices@bsigroup.com

Subscriptions

Tel: +44 345 086 9001

Email: subscriptions@bsigroup.com

Knowledge Centre

Tel: +44 20 8996 7004

Email: knowledgecentre@bsigroup.com

Copyright & Licensing

Tel: +44 20 8996 7070

Email: copyright@bsigroup.com

BSI Group Headquarters

389 Chiswick High Road London W4 4AL UK