

BS ISO 15118-3:2015



BSI Standards Publication

Road vehicles — Vehicle to grid communication interface

Part 3: Physical and data link layer requirements

bsi.

...making excellence a habit.™

National foreword

This British Standard is the UK implementation of ISO 15118-3:2015.

The UK participation in its preparation was entrusted to Technical Committee AUE/16, Data Communication (Road Vehicles).

A list of organizations represented on this committee can be obtained on request to its secretary.

This publication does not purport to include all the necessary provisions of a contract. Users are responsible for its correct application.

© The British Standards Institution 2015. Published by BSI Standards Limited 2015

ISBN 978 0 580 75445 6

ICS 43.120

Compliance with a British Standard cannot confer immunity from legal obligations.

This British Standard was published under the authority of the Standards Policy and Strategy Committee on 30 June 2015.

Amendments issued since publication

Date	Text affected
------	---------------

INTERNATIONAL
STANDARD

ISO
15118-3

First edition
2015-05-15

**Road vehicles — Vehicle to grid
communication interface —**

Part 3:
**Physical and data link layer
requirements**

*Véhicules routiers — Interface de communication entre véhicule et
réseau électrique —*

*Partie 3: Exigences relatives à la couche physique et à la couche
liaison de données*



Reference number
ISO 15118-3:2015(E)

© ISO 2015



COPYRIGHT PROTECTED DOCUMENT

© ISO 2015, Published in Switzerland

All rights reserved. Unless otherwise specified, no part of this publication may be reproduced or utilized otherwise in any form or by any means, electronic or mechanical, including photocopying, or posting on the internet or an intranet, without prior written permission. Permission can be requested from either ISO at the address below or ISO's member body in the country of the requester.

ISO copyright office
Ch. de Blandonnet 8 • CP 401
CH-1214 Vernier, Geneva, Switzerland
Tel. +41 22 749 01 11
Fax +41 22 749 09 47
copyright@iso.org
www.iso.org

Contents

Page

Foreword	v
Introduction	vi
1 Scope	1
2 Normative references	1
3 Terms and definitions	1
4 Symbols and abbreviated terms	4
5 Conventions	5
5.1 Definition of OSI based services.....	5
5.2 Requirement structure.....	5
5.3 Normative references convention.....	5
6 System architecture	6
6.1 Communication layers overview.....	6
6.2 Definition of high-level communication and basic signalling.....	7
6.2.1 Basic signalling.....	7
6.2.2 High-level communication.....	7
6.3 Identification requirements.....	8
6.4 System requirements.....	8
6.4.1 Overview.....	8
6.4.2 EVSE.....	8
6.4.3 EV.....	9
6.5 Configuration of a low-layer communication module.....	10
7 Connection coordination	10
7.1 General.....	10
7.2 Overview.....	10
7.3 Plug-in phase.....	17
7.3.1 EVSE side.....	17
7.3.2 EV side.....	17
7.4 Initialization phase.....	17
7.5 Loss of communication.....	18
7.5.1 EVSE side.....	18
7.5.2 EV side.....	18
7.6 Sleep mode and wake-up.....	19
7.6.1 Entering the sleep mode.....	19
7.6.2 Wake-up.....	19
7.6.3 During a charge pause.....	20
7.7 Plug-out phase.....	20
8 Timings and constants	21
9 Matching EV — EVSE process	22
9.1 Overview.....	22
9.2 Initialization of matching process.....	24
9.3 Discovery of the connected low-layer communication module.....	24
9.4 Validation of matching decision.....	25
9.5 Set-up a logical network.....	27
9.6 Leave the logical network.....	27
9.7 Error handling.....	27
10 EMC requirements	27
11 Signal coupling	27
12 Layer 2 interfaces	28
12.1 Overview.....	28

12.2	Data SAP.....	28
12.3	Data link control SAP to layer 3.....	28
Annex A (normative) HomePlug Green PHY on control pilot line		30
Annex B (informative) IEEE 1901.2 G3-PLC profile on control pilot line.....		72
Bibliography.....		79

Foreword

ISO (the International Organization for Standardization) is a worldwide federation of national standards bodies (ISO member bodies). The work of preparing International Standards is normally carried out through ISO technical committees. Each member body interested in a subject for which a technical committee has been established has the right to be represented on that committee. International organizations, governmental and non-governmental, in liaison with ISO, also take part in the work. ISO collaborates closely with the International Electrotechnical Commission (IEC) on all matters of electrotechnical standardization.

The procedures used to develop this document and those intended for its further maintenance are described in the ISO/IEC Directives, Part 1. In particular the different approval criteria needed for the different types of ISO documents should be noted. This document was drafted in accordance with the editorial rules of the ISO/IEC Directives, Part 2 (see www.iso.org/directives).

Attention is drawn to the possibility that some of the elements of this document may be the subject of patent rights. ISO shall not be held responsible for identifying any or all such patent rights. Details of any patent rights identified during the development of the document will be in the Introduction and/or on the ISO list of patent declarations received (see www.iso.org/patents).

Any trade name used in this document is information given for the convenience of users and does not constitute an endorsement.

For an explanation on the meaning of ISO specific terms and expressions related to conformity assessment, as well as information about ISO's adherence to the WTO principles in the Technical Barriers to Trade (TBT) see the following URL: [Foreword - Supplementary information](#)

The committee responsible for this document is ISO/TC 22, *Road vehicles*, Subcommittee SC 31, *Data communication*.

ISO 15118 consists of the following parts, under the general title *Road vehicles — Vehicle to grid communication interface*:

- *Part 1: General information and use-case definition*
- *Part 2: Network and application protocol requirements*
- *Part 3: Physical layer and Data Link Layer requirements*

The following parts are under preparation:

- *Part 4: Network and application protocol conformance test*
- *Part 5: Physical layer and data link layer conformance test*
- *Part 6: General information and use-case definition for wireless communication*
- *Part 7: Network and application protocol requirements for wireless communication*
- *Part 8: Physical layer and data link layer requirements for wireless communication*

Introduction

The pending energy crisis and the necessity to reduce greenhouse gas emissions has led the vehicle manufacturers to a very significant effort to reduce the energy consumption of their vehicles. They are presently developing vehicles partly or completely propelled by electric energy. Thus, vehicles will reduce the dependency on oil, improve the global energy efficiency, and reduce the total CO₂ emissions for road transportation if the electricity is produced from renewable sources. To charge the batteries of such vehicles, specific charging infrastructure is required.

Much of the standardization work on dimensional and electrical specifications of the charging infrastructure and the vehicle interface is already treated in the relevant ISO or IEC groups. However, the question of information transfer between the vehicle and the grid has not been treated sufficiently.

Such communication is beneficial for the optimization of energy resources and energy production systems as vehicles can recharge at the most economic or most energy-efficient instants.

It is also required to develop efficient and convenient payment systems in order to cover the resulting micro-payments. The necessary communication channel might serve in the future to contribute to the stabilization of the electrical grid, as well as to support additional information services required to operate electric vehicles efficiently.

Road vehicles — Vehicle to grid communication interface —

Part 3: Physical and data link layer requirements

1 Scope

This part of ISO 15118 specifies the requirements of the physical and data link layer for a high-level communication, directly between battery electric vehicles (BEV) or plug-in hybrid electric vehicles (PHEV), termed as EV (electric vehicle) [ISO-1], based on a wired communication technology and the fixed electrical charging installation [Electric Vehicle Supply Equipment (EVSE)] used in addition to the basic signalling, as defined in [IEC-1].

It covers the overall information exchange between all actors involved in the electrical energy exchange. ISO 15118 (all parts) is applicable for manually connected conductive charging.

Only “[IEC-1] modes 3 and 4” EVSEs, with a high-level communication module, are covered by this part of ISO 15118.

2 Normative references

The following documents, in whole or in part, are normatively referenced in this document and are indispensable for its application. For dated references, only the edition cited applies. For undated references, the latest edition of the referenced document (including any amendments) applies.

ISO 15118-1:2013, *Road vehicles — Vehicle to grid communication interface — Part 1: General information and use-case definition*

ISO 15118-2:2014, *Road vehicles — Vehicle to grid communication interface — Part 2: Network and application protocol requirements*

IEC 61851-1:2010, *Electric vehicle conductive charging system — Part 1: General requirements*

IEC/TS 62763:2013, *Pilot function through a control pilot circuit using PWM (pulse width modulation) and a control pilot wire*

3 Terms and definitions

For the purposes of this document, the terms and definition in [ISO-1] and the following apply.

3.1

amplitude map

specifies a transmit power-reduction factor for each subcarrier related to the tone mask

3.2

central coordinator

manager of a HomePlug Green PHY network

3.3

channel access priority

CAP

method to prioritize the channel access

Note 1 to entry: See [HPGP].

3.4

coexistence

ability of different low-layer communication systems to share the same physical media and to function simultaneously

3.5

communication media

physical media carrying the low-layer communication signal is given by the cable assembly, which connects the charging infrastructure and the EV

3.6

communication node

device equipped with a low-layer communication modem chip; it characterizes one logical and physical communication device that is attached to a physical media and is capable of sending, receiving, or forwarding information over a communication channel

3.7

connection coordination

entity which provides the whole functionality for EV to EVSE matching and initialization, through the data link control SAP, described in [Clause 6](#)

Note 1 to entry: This entity also controls the relationships between the basic signalling and the upper layers.

3.8

crosstalk

capacitive or inductive coupling between two individual electric circuits, each providing a media for a low-layer communication network, in a way that the two networks are influenced by each other

3.9

data link control SAP

service access point which defines the interface between the connection coordination module and the low-layer communication technology for managing the link status

3.10

DATA SAP

service access point that defines the interface between layer 2 and layer 3 for exchange of v2g-related payload

3.11

ETH SAP

Ethernet II-class SAP supports applications using Ethernet II class packets, including IEEE 802.3 with or without IEEE 802.2 (LLC), IEEE 802.1H (SNAP) extensions, and/or VLAN tagging

3.12

external identification means

EIM

any external means that enable the user to identify his contract or the car

3.13

initialization

process of interaction between the EV, EVSE, and an external trigger, beginning from plug-in of the cable assembly until the decision for the charging mode to be applied

Note 1 to entry: This process is used for the charging modes 3 and 4, as described in *[IEC-1]*.

3.14

IO SAP

IO control path interfaces hardware i/o control (e.g. control pilot duty cycle) and the control pilot wire

Note 1 to entry: This entity provides an IO SAP, which is defined in [Clause 12](#).

3.15

inter system protocol

enables various broadband power line systems to share power line communication resources in time (time domain multiplex), in frequency (frequency domain multiplex), or both

Note 1 to entry: For more information, refer to [IEEE].

3.16

logical network

set of low-layer communication stations which use the same network key

Note 1 to entry: Only members of the same logical network are able to exchange encrypted payload data and are visible for each other on higher layers. Different logical networks might exist on the same physical media at the same time and are typically used for network segmentation.

Note 2 to entry: A logical network is defined for layer 2.

3.17

low-layer communication

functions managed by the OSI layer 1 and layer 2 of the modem

3.18

low-layer communication module

functional assembly behind each socket outlet or each connector, depending on the type of EV connection ([IEC-1]), which includes the communication node and the connection coordination functionality

3.19

MAC address

unique identifier assigned to network interfaces for communication on the data link layer

3.20

management message entry

MME

messages exchanged between PLC nodes or a PLC node and higher layers for control purposes

3.21

matching

process to determine the low-layer communication modules of EV and EVSE, where EV is physically connected to, in a direct way

Note 1 to entry: "Matching" refers to "Association" (use-case A) in ISO 15118-1.

3.22

nominal duty cycle

10 % to 96 % control pilot duty cycle, according to [IEC-1], generated by the EVSE

3.23

pilot function controller

system that manages the control pilot line on the EVSE side, according to [IEC-1]

3.24

plug and charge

identification mode where the customer just has to plug their vehicle into the EVSE and all aspects of charging are automatically taken care of with no further intervention from the customer

3.25

QPSK modulation

phase modulation technique that transmits two bits in four modulation states

3.26

ROBO mode

communication mode which uses QPSK only for carrier modulation within the orthogonal frequency division multiplexing (OFDM) to achieve higher robustness in transmission

Note 1 to entry: The ROBO mode can be set to three different performance levels: Mini-ROBO, Standard ROBO, and High-speed ROBO.

3.27

shared bandwidth

in cases where different systems use the same physical media to transmit data, the data rate for each system might be limited, depending on the mechanism used to allocate it

3.28

signal coupling

method of coupling the signal on the communication media

3.29

signal level attenuation characterization

SLAC

protocol to measure the signal strength of a signal between HomePlug Green PHY stations

3.30

tone mask

defines the set of tones (or carriers) that can be used in a given regulatory jurisdiction or given application

3.31

valid duty cycle

duty cycle that is 5 % or 10 % to 96 %, according to [IEC-1], generated by the EVSE

4 Symbols and abbreviated terms

ARIB	Association of Radio Industries and Businesses
CAP	Channel Access Priority
CCo	Central Coordinator
D-LINK	Data Link
EIM	External Identification Mean (as defined in ISO 15118-1)
ERDF	Electricité et Réseau de France
FCC	Federal Communications Commission
HLE	Higher Layers Entities
HPGP	HomePlug Green PHY
ID	Identification
IEEE	Institute of Electrical and Electronics Engineers
ISP	Intersystem Protocol
ITU	International Telecommunication Union
MAC	Media Access Control

MME	Management Message Entry
PE	Protective Earth
PLC	Power Line Communication
PnC	Plug and Charge (as defined in ISO 15118-1)
QPSK	Quadrature Phase Shift Keying
SAP	Service Access Point
SE	Supply Equipment
SLAC	Signal Level Attenuation Characterization

5 Conventions

5.1 Definition of OSI based services

[ISO-3] is based on the OSI service conventions (ISO/IEC 10731:1994) for the individual layers specified in this part of ISO 15118.

5.2 Requirement structure

Each individual requirement included in this part of ISO 15118 has a unique code, e.g. [V2G3-YXX-ZZZ] requirement text, where

- “V2G3” represents the [ISO-3] set of standards,
- “Y” represents the main body (M)/Annexes (Annexes’ letter),
- “XX” represents the number of the current clause,
- “ZZZ” represents the individual requirement number and
- “requirement text” includes the actual text of the requirement.

EXAMPLE [V2G3-M01-01] This shall be an example requirement.

5.3 Normative references convention

Each reference to a normative document has the following unique codes assigned:

[IEC-1]	IEC 61851-1
[IEC-21]	IEC 61851-21
[IEC-22]	IEC 61851-22
[IEC-2]	IEC 62196-2
[IEC-3]	IEC/TS 62763
[ISO-0]	ISO 15118-series
[ISO-1]	ISO 15118-1
[ISO-2]	ISO 15118-2

[ISO-3] ISO 15118-3

6 System architecture

6.1 Communication layers overview

This part of ISO 15118 is organized along architectural lines, emphasizing the large-scale separation of the system into two parts: the MAC sublayer of the data link layer and the physical layer. These layers are intended to correspond closely to the lowest layers of the ISO/IEC model for open systems. [Figure 1](#) shows the relationship of the [ISO-3] to the OSI reference model.

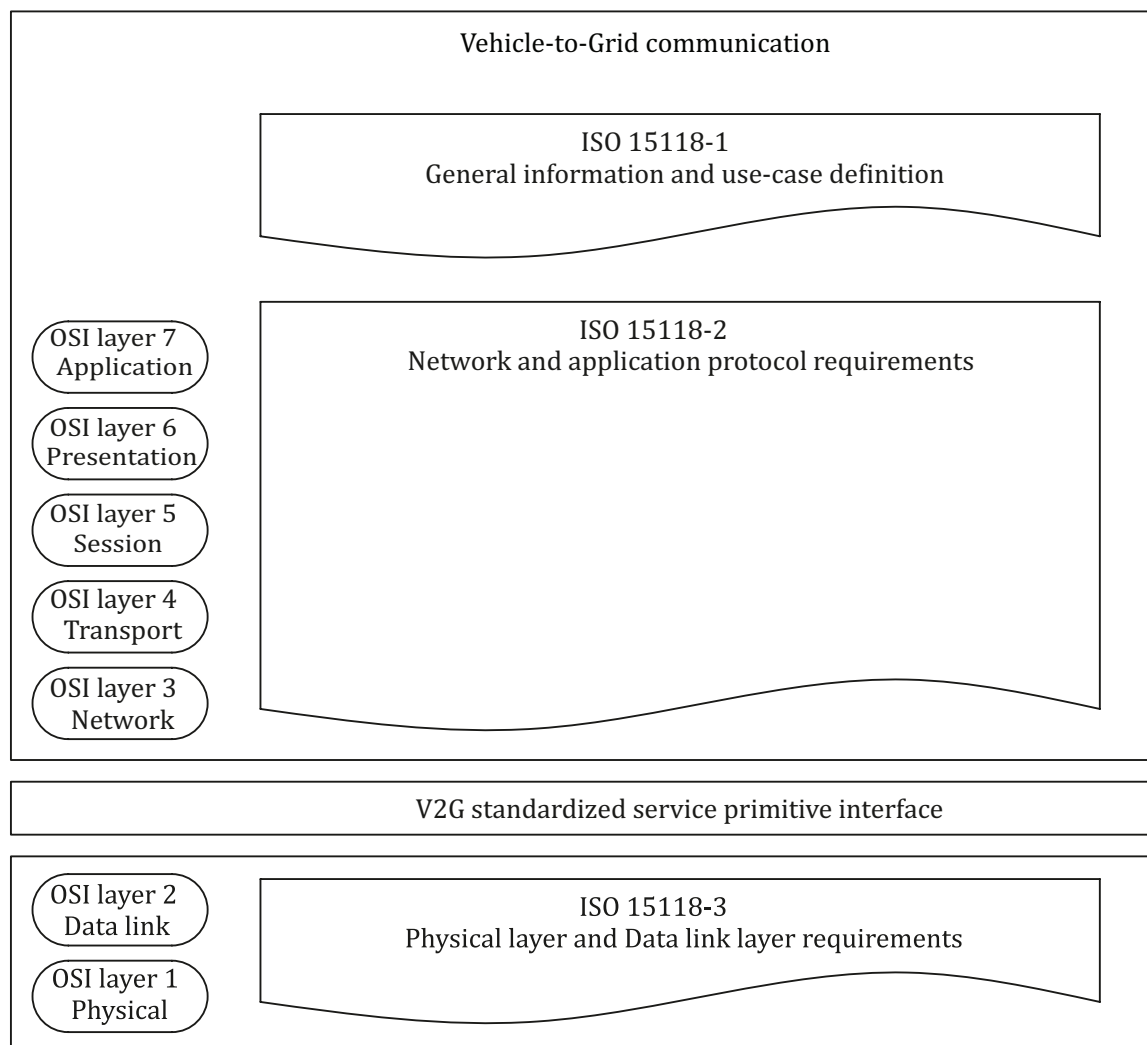

Figure 1 — Overview of [ISO-0] in the ISO/IEC OSI reference model

[ISO-3] defines requirements applicable to layer 1 and layer 2, including V2G standardized service primitive interface, according to the OSI layered architecture. Layer 3 to layer 7 is specified in [ISO-2].

Beside the communication related stack on the left and middle of [Figure 2](#), a hardware control path on the right provides triggering and signalling means for [IEC-1] related signalling.

This part of ISO 15118 is covering both AC and DC use-cases. If not defined differently, requirements apply for both AC and DC.

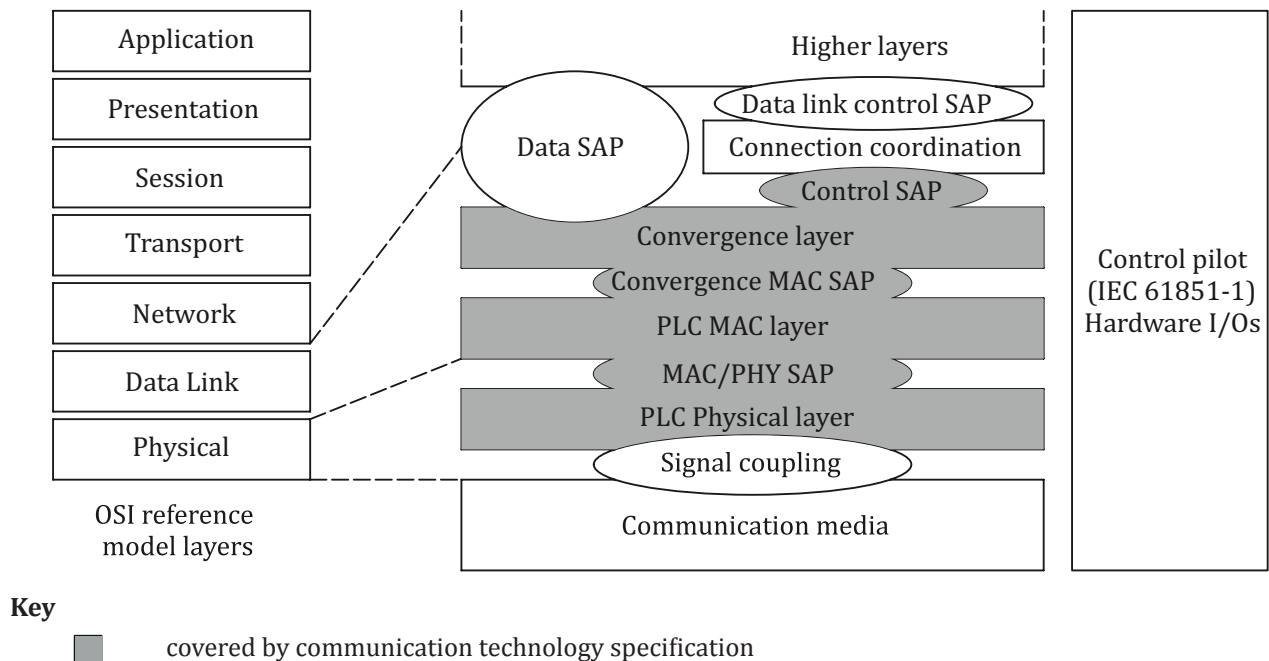

Figure 2 — [ISO-3] relationship to the ISO/IEC OSI reference model

6.2 Definition of high-level communication and basic signalling

This part of ISO 15118 describes in the main body, the general requirements to the communication. Specific requirements depending on the technology are described in the [Annex A](#).

6.2.1 Basic signalling

[V2G3-M06-01] The basic signalling follows [IEC-1]. All timings shall be compliant with the [IEC-1], Annex A.

Any charging process, no matter the presence of high-level communication, uses the bidirectional signalling according to [IEC-1], indicating EV related information through control pilot states and EVSE related information through the duty cycle of the control pilot signal.

6.2.2 High-level communication

[V2G3-M06-02] The HLC shall be used in addition to the basic signalling in order to enable a bidirectional communication and offer additional features.

The sequence of the data exchange within the HLC-based charging session is done in accordance with the [ISO-2] communication protocol.

It can be split into three periods as follows:

- data link setup;
- V2G setup;
- V2G charging loop.

NOTE The detailed descriptions are given in [ISO-2].

[V2G3-M06-03] During the V2G charging loop, the PWM duty cycle shall not change due to dynamically changed grid information. Those dynamically changed grid limitations shall be provided through the high-level communication messages.

In case basic charging is used as back-up of HLC-C (e.g. when HLC-C has failed), the duty cycle is allowed to change due to dynamically changed grid information, according *[IEC-1]* requirements.

6.3 Identification requirements

The initialization phase depends on whether identification “ID from EV” or EIM is required, as described in *[ISO-1]*, use-cases D1, D2, D3, and D4.

[V2G3-M06-04] When authorization (payment) is required for charging, the EVSE shall offer PnC (ID from EV) or EIM means.

Any payment included in a package (parking fee, in a flat rate, etc.) is considered as “No ID required” since the energy is paid for by means totally independent of the EVSE.

NOTE 1 The need for authentication can be externally triggered.

NOTE 2 The “ID required” covers only the ID for operating purposes and does not cover all the identification linked to the “security” as described in the *[ISO-2]*.

NOTE 3 The feature PnC is called “ID from EV”, using the message set of *[ISO-2]*.

NOTE 4 At a publicly accessible EVSE with only “ID from EV”, there might be a fallback solution to allow any EV to be able to charge.

If the duty cycle is set to 5 % and PnC is intended to be used, the EVCC may launch an “ID recognition” from the EV (Use-case D1 and D2 of *[ISO-1]*). According to the EV’s answer, the SECC may decide to allow the charge or not.

6.4 System requirements

In the following subclauses, the abbreviations concerning the control pilot states (eg X1, X2, B1, B2, etc.), are described in *[IEC-3]*.

6.4.1 Overview

This Clause defines the requirements on the triggering of the EVSE and the EV immediately after the plug-in of the cable assembly. It includes the specifications of sequences, when and how the contract ID is recognized, when to launch the matching process (at the MAC level), and how to decide to use basic charging or high-level communication charging.

6.4.2 EVSE

6.4.2.1 Control pilot requirements

Each EVSE outlet has its own dedicated pilot function controller.

The trigger and timing relations between basic signalling and HLC connection setup are described in [Clause 7](#).

For implementation and synchronization between *[IEC-1]* and *[ISO-3]*, please refer to *[ISO-2]* 8.7.4.

NOTE 1 If a nominal duty cycle is set, it is recommended to keep it as the maximum current capacity of the charging station and let the high-level communication messages dynamically adjust the available max current.

[V2G3-M06-05] In case no communication could be established with a 5 % control pilot duty cycle (matching process not started), if the EVSE wants to switch to a nominal duty cycle, then the change from 5 % to a nominal duty cycle shall be done with a specific sequence B2 or C2 (5 %) -> E or F -> B2 (nominal value) to allow backward compatibility. The minimum time at the control pilot state E or F is defined to T_step_EF.

NOTE 2 Each EVSE supplier is free to choose between the state E and the state F to make the transition, according to its implementation.

[V2G3-M06-06] In case a communication has already been established within 5 % control pilot duty cycle ("Matched state" reached or matching process ongoing), a change from 5 % to a nominal duty cycle shall be done with a X1 state in the middle (minimum time as defined in [IEC-3] Seq 9.2), to signal the EV that the control pilot duty cycle will change to a nominal duty cycle.

[V2G3 M06-07] If an AC EVSE applies a 5 % control pilot duty cycle, and the EVSE receives no SLAC request within TT_EVSE_SLAC_init, the EVSE shall go to state E or F for T_step_EF, shall go back to 5 % duty cycle, and shall reset the TT_EVSE_SLAC_init timeout before being ready to answer a matching request again. This sequence shall be retried C_sequ_retry times. At the end, without any reaction, the EVSE shall go to state X1.

NOTE 3 In the X1 control pilot state, a customer can make an EIM action at any time.

[V2G3-M06-08] After positive EIM, if no matching process is running, the EVSE shall signal control pilot state E/F for T_step_EF, then signal control pilot state X1/X2 (nominal).

[V2G3 -M06-09] If a control pilot state E/F -> Bx, Cx, Dx transition is used for triggering retries or legacy issues, the state E/F shall be at least T_step_EF.

6.4.2.2 Low-layer communication requirements

The [ISO-1], Annex A provides examples for charging infrastructure architectures.

The matching process is designed for working between the low-layer communication module locally assigned to each socket-outlet, on the EVSE side, and the EVCC.

NOTE 1 The complete matching process description is given in [Clause 9](#).

[V2G3-M06-10] In case of charging station enclosures with multiple socket-outlets or attached cables and only one low-layer communication module managing the complete station, these shall behave as an individual low-layer communication module for each outlet.

NOTE 2 It's highly recommended to build a point to point architecture (one low-layer communication module on EVSE side, and one low-layer communication module per EV).

[V2G3-M06-11] The matching process shall be launched by a transition from state A, E, or F to state Bx, Cx, or Dx.

6.4.3 EV

6.4.3.1 Control pilot requirements

On seeing a nominal duty cycle, the EV may launch the charge at any time.

[V2G3-M06-12] In the HLC-C mode, in case of a nominal duty cycle, the vehicle shall determine the maximum charge current, defined by the EVSE, by calculating the minimum of the following values:

- maximum charge current given by the control pilot duty cycle;
- maximum charge current given by the HLC-C messages.

6.4.3.2 Low-layer communication requirements

[V2G3-M06-13] The matching process shall be launched by a transition from state A, E, or F to state Bx, Cx, or Dx.

[V2G3-M06-14] The EV shall always charge in the HLC-C mode, as soon as V2G charging loop is started.

Within the V2G charging loop, the EV is not allowed to charge in the basic charging mode.

Before the V2G charging loop and after the V2G communication session, the EV is allowed to charge in the basic charging mode in case of nominal control pilot duty cycle.

In case of AC-charging, an EV should be capable to switch from a HLC-C mode to a basic charging mode, if an error occurs on the high-level communication, even if a HLC-C mode is already launched.

[V2G3-M06-15] During a matching process, a change in the duty cycle shall not terminate/interrupt the matching process on EV side.

6.5 Configuration of a low-layer communication module

If there is a coexistence issue with the grid, technical decisions including application of alternative PLC standard technologies like ISO/IEC 12139-1, should be considered in that situation: KR.

Coexistence mechanisms are not defined in this part of ISO 15118.

[V2G3-M06-16] Each communication node shall provide a method to exchange authorized frequencies to be used, to be in line with frequency restrictions. A communication node shall respect the spectrum limitation sent by the counterpart node.

NOTE All EVSEs should be able to update the set of frequencies to be used according to future legislative regulations.

7 Connection coordination

7.1 General

This Clause describes the behaviour of the system, at different phases of a charging session, between a plug-in and a plug-out.

7.2 Overview

[Table 1](#) gives a summary of PnC and/or EIM implementation on EVSEs. Details are given in the following figures. For example, Seq 1 b), c), and d) means that the branches b), c), and d) apply.

Table 1 — EIM and/or PnC in EVSEs

	Figure no.	Description	PnC	EIM with BC	EIM w/o BC	IEC 61851-1 charging
AC EVSE	Figure 3	Seq1. Matching not started (start with 5 %)	a)	b)	c)	d)
	Figure 4	Seq2. Matching not started (start with X1)	a)	b)	c)	d)
	Figure 5	Seq3. Matching started (start with 5 %)	a)	b)	c)	-
	Figure 6	Seq4. Matching started (start with X1)	a)	b)	c)	-
	Figure 7	Seq5. EIM before plug-in	-	b)	c)	d)
DC EVSE	Figure 8	Seq6.	a)	-	c)	-

The following figures show EVSEs control pilot handling for different scenarios. Re-init means a restart of the session (without plug-in/out) by control pilot state E transition (e.g. error handling).

[Figure 3](#) shows an AC EVSE supporting HLC-C with PnC and EIM. The matching process is not started when EIM is done. The EVSE applies 5 % control pilot duty cycle after plug-in. Control pilot state X1 could be applied for a short time until the control pilot oscillator is switched on. If an EVSE only supports EIM or PnC, only some branches exist.

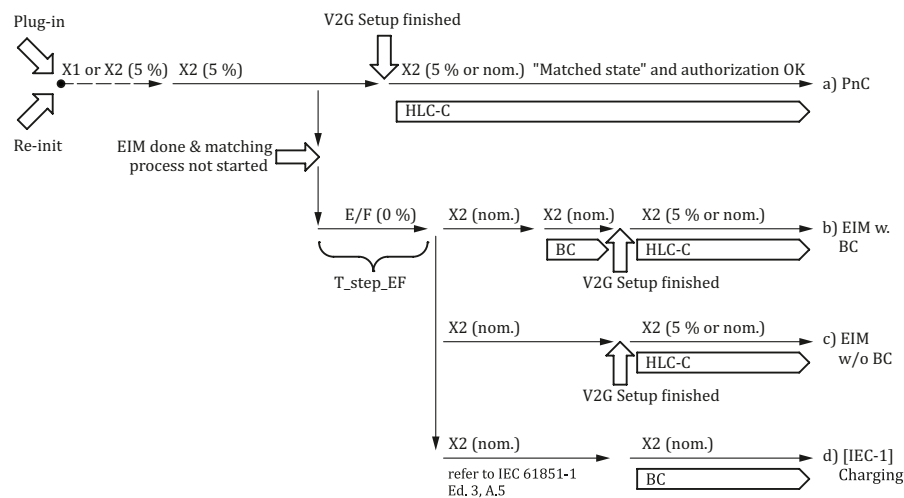

Key

- > possible procedure
- > mandatory procedure
- HLC-C charging controlled by high-level communication
- BC charging controlled by IEC 61851-1
- ⇒ trigger condition

NOTE 1 CP state X1 is allowed instead of X2 (nom.) following [IEC-3] (Table 5, X1 state usage).

NOTE 2 Branch d) is for EVs not supporting HLC-C.

Figure 3 — Connection coordination Seq 1: AC EVSE with PnC and EIM and matching process not started before EIM, 5 % control pilot duty cycle after plug-in

Figure 4 shows an AC EVSE supporting HLC-C with PnC and EIM. The matching process is not started when EIM is done. The EVSE applies control pilot state X1 after plug-in. If an EVSE only supports EIM or PnC, only some branches exist.

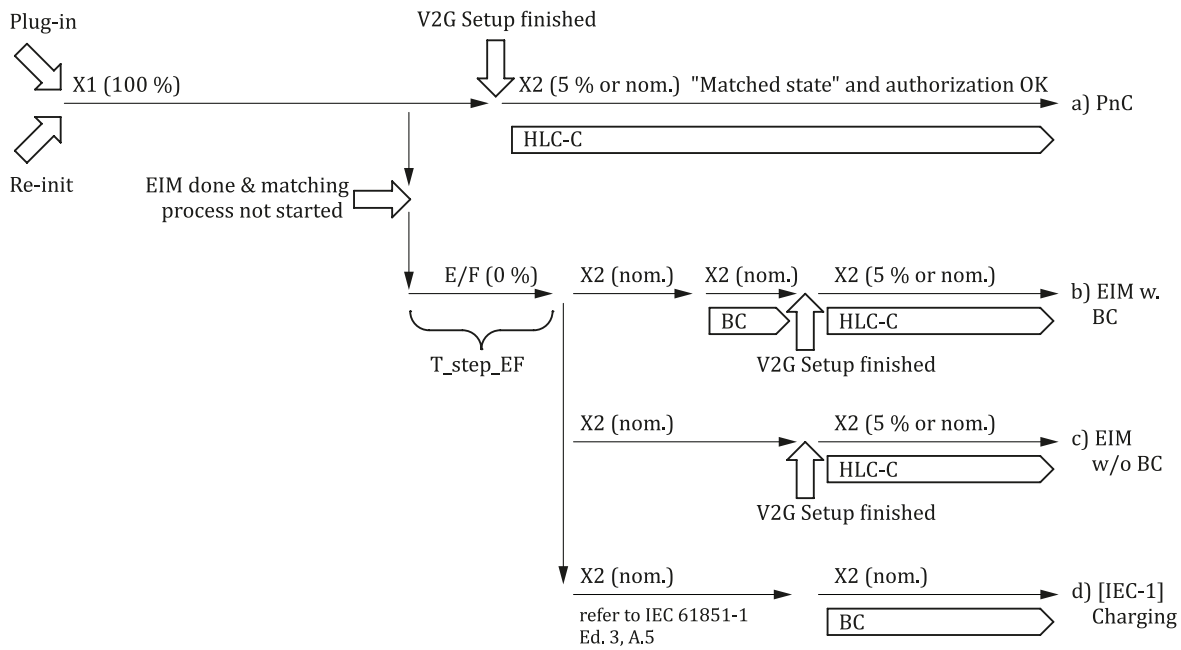

- Key**
- > possible procedure
 - > mandatory procedure
 - HLC-C charging controlled by high-level communication
 - BC charging controlled by IEC 61851-1
 - ⇨ trigger condition

NOTE 1 CP state X1 is allowed instead of X2 (nom.) following [IEC-3] (Table 5, X1 state usage).

NOTE 2 Branch d) is for EVs not supporting HLC-C.

Figure 4 — Connection coordination Seq 2: AC EVSE with PnC and EIM and matching process not started before EIM, control pilot state X1 after plug-in

Figure 5 shows an AC EVSE supporting HLC-C with PnC and EIM. The matching process is already started when EIM is done. The EVSE applies 5 % control pilot duty cycle after plug-in. Control pilot state X1 could be applied for a short time until the control pilot oscillator is switched on. If an EVSE only supports EIM or PnC, only some branches exist.

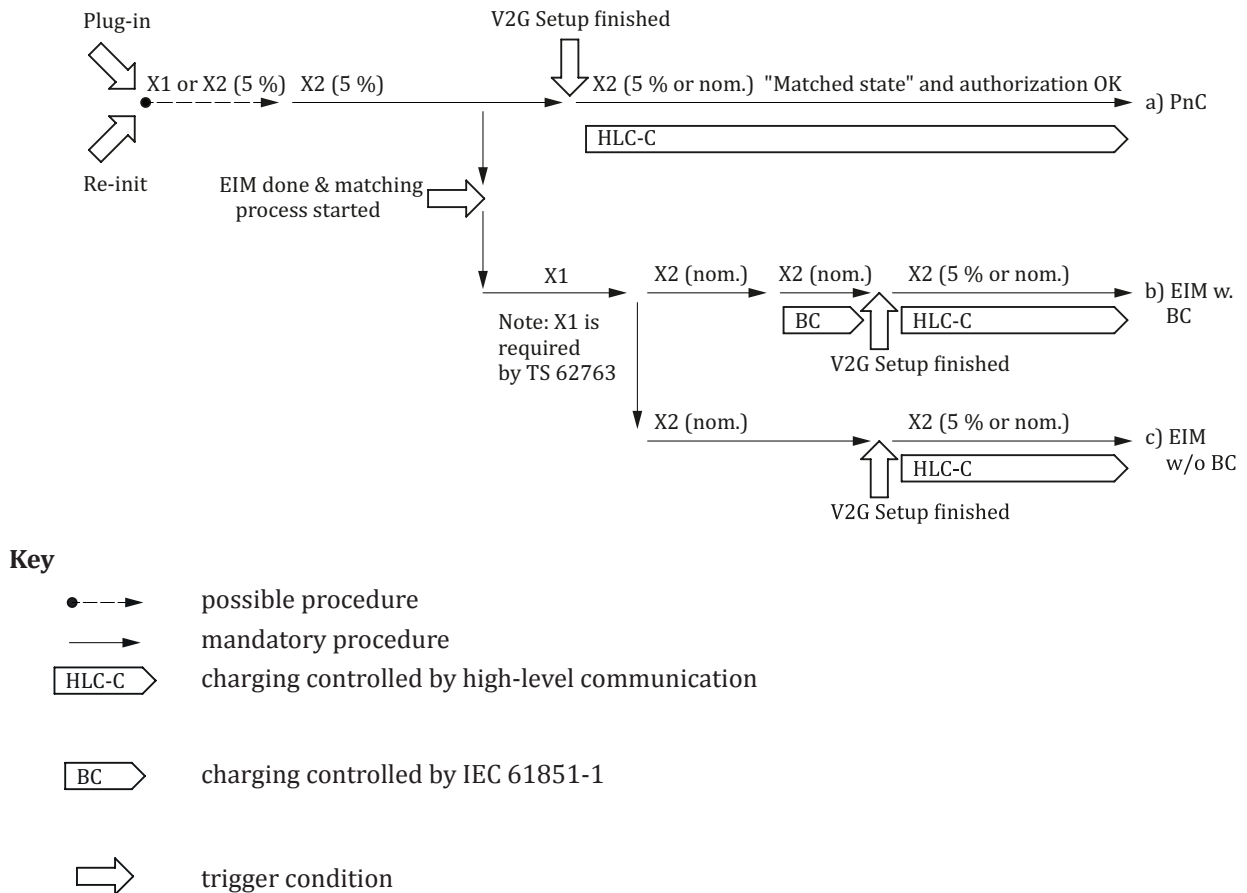

NOTE CP state X1 is allowed instead of X2 (nom.) following [IEC-3] (Table 5, X1 state usage).

Figure 5 — Connection coordination Seq 3: AC EVSE with PnC and EIM and matching process started before EIM, 5 % control pilot duty cycle after plug-in

Figure 6 shows an AC EVSE supporting HLC-C with PnC and EIM. The matching process is already started when EIM is done. The EVSE applies control pilot state X1 after plug-in. If an EVSE only supports EIM or PnC, only some branches exist.

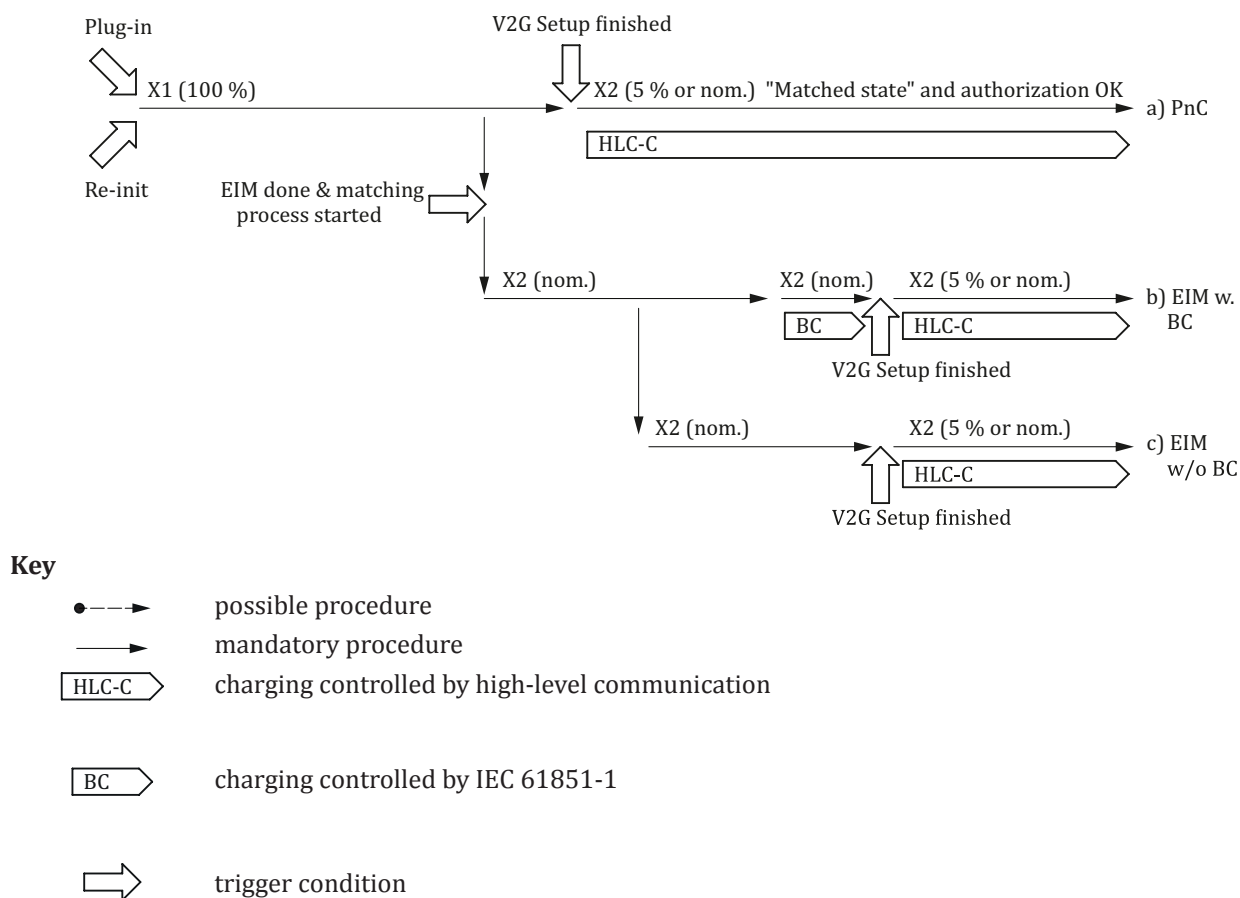

NOTE CP state X1 is allowed instead of X2 (nom.) following [IEC-3] (Table 5, X1 state usage).

Figure 6 — Connection coordination Seq 4: AC EVSE with PnC and EIM and matching process started before EIM, control pilot state X1 after plug-in

Figure 7 shows an AC EVSE supporting HLC-C with PnC and EIM. EIM is done before plug-in.

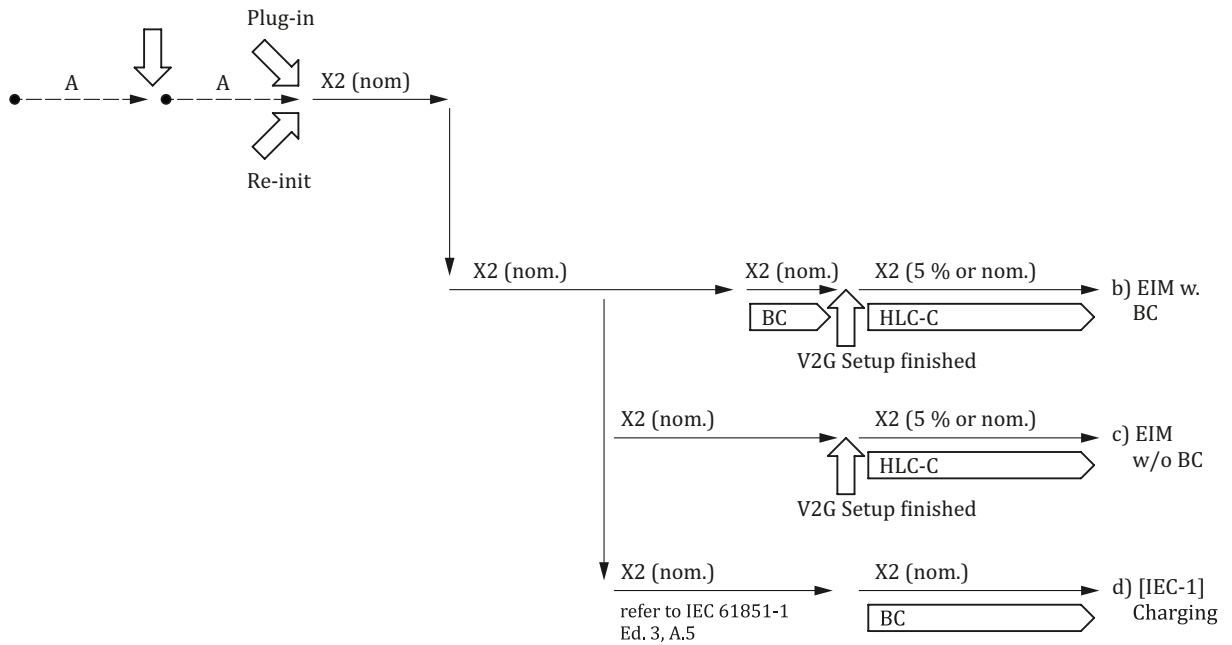

Key

- > possible procedure
- > mandatory procedure
- HLC-C charging controlled by high-level communication
- BC charging controlled by IEC 61851-1
- ⇨ trigger condition

NOTE CP state X1 is allowed instead of X2 (nom.) following [IEC-3] (Table 5, X1 state usage).

Figure 7 — Connection coordination Seq 5: AC EVSE with EIM, EIM before plug-in, control pilot state X2 after plug-in

Figure 8 shows a DC EVSE supporting HLC-C with PnC and EIM. First branch shows a PnC case. Second branch shows a case where EIM is done after plug-in. Third branch shows a case where EIM is done before plug-in.

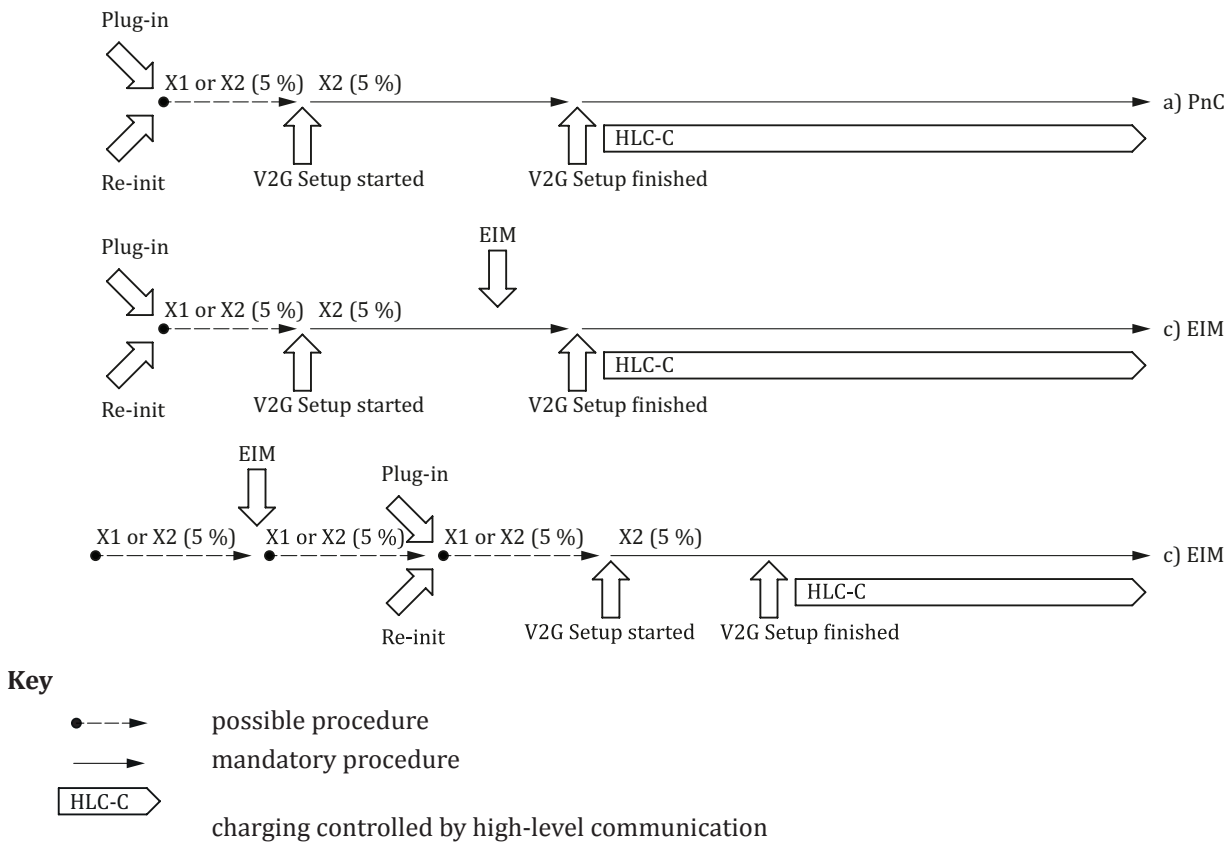

Figure 8 — Connection coordination Seq 6: DC EVSE with PnC and EIM

Figure 9 Shows AC EVSE control pilot timeout handling for 5 % control pilot duty cycle. See [V2G3 M06-07].

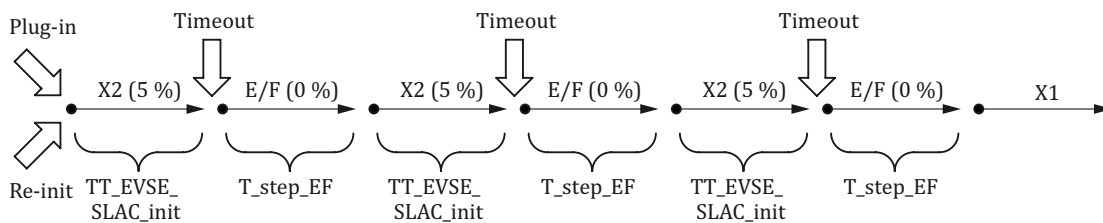

Figure 9 — Connection coordination Seq 7: AC EVSE timeout handling for 5 % control pilot duty cycle

Table 2 shows the options for EVs with and without HLC, according to the different control pilot duty cycle values.

Table 2 — EV behaviour

Duty cycle seen by the EV	EV w/o HLC	EV with HLC
B1	no reaction	Matching process to be launched If the EV_Discovering_Status is "EVSE_FOUND": V2G Setup finished: wait If EV_Discovering_Status = EVSE_NOT_FOUND: no reaction
5 %	no reaction	Matching process to be launched If the EV_Discovering_Status is "EVSE_FOUND": V2G Setup finished: continue with negotiated charge profile If EV_Discovering_Status = "EVSE_NOT_FOUND": no reaction
X2 (nom)	BC	BC is allowed In parallel, matching to be launched When EV_Discovering_Status = EVSE_FOUND: HLC can begin at any time. If EV_Discovering_Status = EVSE_NOT_FOUND: BC allowed or no reaction.
NOTE No reaction means that the EV may go to sleep, according to the implementation.		

7.3 Plug-in phase

This phase covers the plug-in up to the beginning of the charge.

7.3.1 EVSE side

[V2G3-M07-01] After successful detection of the plug-in of a cable assembly, the low-layer communication module shall be ready for communication in less than T_conn_max_comm.

NOTE 1 Plug-in detection by EVSE can be done either by proximity pin detection or by closed control pilot.

During a plug-in phasis, AC EVSEs with Type 2 outlet or DC EVSEs with Type 1 connector should only apply a voltage to the control pilot when the low-layer communication module is ready for communication. This speeds up the communication setup.

[V2G3-M07-02] The EVSE shall only apply 5 % control pilot duty cycle if the low-layer communication module is ready for communication (receive first SLAC message).

According to the initialization process, an EVSE should be prepared to receive EIM identification, if offered, at any time.

NOTE 2 The EIM sequence is compliant with the use-case A2 from [ISO-1].

7.3.2 EV side

When detecting a nominal duty cycle, the EV can either start charging in the basic charging mode or wait until the HLC-C mode is established.

7.4 Initialization phase

When the V2G Data link setup is successful and if the PnC identification mode is implemented, further identification is managed by higher layers as described in [ISO-2] (e.g. ID recognition).

According to that ID recognition, the EVSE will decide whether to authorize the charge or to not authorize the charge.

7.5 Loss of communication

This Clause covers the situation where the communication link is lost. A loss of communication after the establishment of a data link [D-LINK_READY.indication(link established) was already indicated] is handled by higher layers, by requesting with D-LINK_ERROR.request.

[V2G3-M07-03] If a data link was established and a D-LINK_READY.indication(link established) was already indicated to higher layers, any detected loss of the data link shall cause a D-LINK_READY.indication(no link) indication to higher layers.

7.5.1 EVSE side

[V2G3-M07-04] With receiving a D-LINK_ERROR.request from HLE in X1 state, the EVSE's communication node shall perform a state X1 to state E/F to state X1 or X2 transition.

7.5.1.1 Error handling with a Control Pilot duty cycle of 5 %

[V2G3-M07-05] With receiving a D-LINK_ERROR.request in X2 state from HLE, the EVSE's communication node shall perform a state X2 to X1 to state E/F to state X1 or X2 transition.

[V2G3-M07-06] Within the control pilot state X1, the communication node shall leave the logical network and change the matching state to "Unmatched".

[V2G3-M07-07] With reaching the state "Unmatched", the EVSE shall switch to state E/F.

[V2G3-M07-08] The state E/F shall be applied at least T_{step_EF} .

[V2G3-M07-09] After applying state E/F, the EVSE shall switch to control pilot state X1 or X2 as soon as the EVSE is ready for incoming matching requests.

7.5.1.2 Error handling with nominal control pilot duty cycle

[V2G3-M07-10] With receiving a D-LINK_ERROR.request from HLE, the EVSE's communication node shall implement one of the two following options:

Option A: to have behaviour independent of the duty cycle:

[V2G3-M07-11] The requirements of [7.5.1.1](#) shall be applied to have behaviour independent of the duty cycle.

Option B: not to interrupt charging due to a control pilot state change to state E:

[V2G3-M07-12] With receiving a D-LINK_ERROR.request from HLE, the EVSE's communication node shall stay in X2 control pilot state, leave the logical network within TP_match_leave, and change the matching state to "Unmatched" to be ready for a new matching process.

7.5.2 EV side

If the EV detects a loss of communication, it can either switch to basic charging mode or stop the charge. While relaunching the matching process, the EV may go on charging in the basic charging mode, if the EVSE sets a nominal duty cycle.

NOTE The matching process after a loss of communication is exactly the same as during a plug-in phasis.

7.5.2.1 Error handling with control pilot duty cycle of 5 %

[V2G3-M07-13] With receiving a D-LINK_ERROR.request from HLE, the EV's communication node shall change to Bx state, leave the logical network and change the matching state to "Unmatched" within TP_match_leave and wait for a new incoming matching trigger (control pilot X1 or X2 state).

7.5.2.2 Error handling with nominal control pilot duty cycle

[V2G3-M07-14] With receiving a D-LINK_ERROR.request from HLE, the EV's communication node shall implement one of the two following options:

Option A: to have behaviour independent of the duty cycle:

[V2G3-M07-15] The requirements of [7.5.2.1](#) shall be applied to have behaviour independent of the duty cycle.

Option B: not to interrupt charging due to a control pilot state change to state E:

[V2G3-M07-16] With receiving a D-LINK_ERROR.request from HLE, the EV's communication node shall keep the current state and leave the logical network and change the matching state to "unmatched".

[V2G3-M07-17] T_conn_resetup after the condition in [V2G3-M07-16] is met; the EV shall restart the Matching process.

[V2G3-M07-18] During the T_conn_resetup waiting state according to [V2G3-M07-17], the EV shall be prepared to be forced to restart by an EVSE, which has implemented option A according to [V2G3-M07-10].

7.6 Sleep mode and wake-up

A sleep mode is used for energy saving. EV and EVSE can enter a sleep mode after negotiating a pause through HLC protocol.

On the EVSE side, a sleep mode means that the oscillator will be off (X1 Control Pilot state), the +12V supply of the pilot line will stay on, and the low-layer communication module may be powered off.

On the EV side, a sleep mode means state B and the low-layer communication module may be powered off. The wake-up mechanisms may also be used after charge session was already terminated to allow the counterpart station to reestablish HLC.

7.6.1 Entering the sleep mode

[V2G3-M07-19] With receiving a D-LINK_PAUSE.request, the EV shall change to control pilot state Bx. Unpowering the low-layer communication module is optional. The logical network parameter set shall be stored for continuing the data link after the sleeping phase.

[V2G3-M07-20] With receiving a D-LINK_PAUSE.request, the EVSE shall switch to control pilot state X1 and may switch the low-layer communication module into low-power mode. The logical network parameter set shall be stored for continuing the data link after the sleeping phase.

7.6.2 Wake-up

[V2G3-M07-21] As soon as the lower layers detect a data link after a wake-up, it shall send a D-LINK_READY.indication(link established) to HLE.

- [V2G3-M07-22] If the EVSE or EV is in “Matched state” and has been woken up from the counterpart station, the low-layer communication module shall be configured to the last known logical network parameter set.
- [V2G3-M07-23] In case of a wake up trigger from the counterpart station, the low-layer communication module shall be ready in maximum T_conn_resume after the trigger (B1/B2, BCB-Toggle).

7.6.2.1 EVSE side

- [V2G3-M07-24] To wake-up the EV, the pilot function controller on EVSE side shall be configured to the last known parameter set and the oscillator shall perform a B1/B2 transition.
- [V2G3-M07-25] As soon as the EVSE is ready to charge and ready to communicate after a wake-up from EV, it shall switch to X2 state.
- [V2G3-M07-26] If the EVSE is in a charge pause, it shall wake up by detecting a BCB-Toggle and shall configure the low-layer communication module to the last known logical network parameter.
- [V2G3-M07-27] If the EVSE does not detect a PLC link after a wake-up for T_conn_max_comm, it shall reinitiate the connection by applying a state E for at least T_step_EF to retrigger the setup of the connection by a matching process as described in 7.5.

7.6.2.2 EV side

- [V2G3-M07-28] In the case the EVSE applies a control pilot state X1 when the EV resumes from sleep state, a single BCB-Toggle shall be performed, as defined in 9.4 to wake up the EVSE.
- [V2G3-M07-29] After waking up, the PLC node on EV side shall be configured to the last known parameter set.
- [V2G3-M07-30] If the EV is in a charge pause, it shall wake up by detecting a control pilot state B1/B2 transition and shall configure the communication module to the last known logical network parameter.

7.6.3 During a charge pause

- [V2G3-M07-31] During a sleeping phasis (EV or EVSE side), the EVSE shall not turn off the +12V supply in order to keep the pilot line alive.
- [V2G3-M07-32] The EVSE shall not asleep its low-layer communication module, if the control pilot oscillator is on.

An EV shall wake-up on detecting a transition B1-> B2, according to [IEC-1].

- [V2G3-M07-33] In case of a control pilot state X2-> X1-> X2 transition, the time at X1 is defined in [IEC-3] seq9.2.

7.7 Plug-out phase

This phase supposes that the customer gave a hint to the system that he wants to unplug.

- [V2G3-M07-34] For an unexpected loss of communication, requirement [V2G3-M09-19] shall be taken into account.

With a type 1 connector, if the customer pushes S3 but doesn't plug-out, the system might relaunch the communication automatically at any time. This doesn't imply to relaunch the identification, if not needed.

With a type 2 connector, if the customer unlocks but doesn't plug-out, the system might relaunch the communication automatically and will relock the connector.

8 Timings and constants

This Clause summarizes all timings used in the main body of this part of ISO 15118.

[V2G3-M08-01] All low-layer communication devices shall comply with [Table 3](#).

Table 3 — Timing and constant values

Parameter	Description	Min	Typical	Max	Unit
C_conn_max_match	Number of retries of matching process	3			nbr
C_EV_vald_nb_toggles	Number of BCB-Toggles	1		3	nbr
C_EVSE_match_parallel	Number of parallel matching processes to be handled by EVSE	5			nbr
C_sequ_retry	Number of matching retries by Control Pilot state E transitions	2	2	2	nbr
T_conn_init_HLC	Minimum B state duration after a state F, D, or C	200			ms
T_conn_resume	Time after the wake up trigger (e.g. BCB-Toggle) until the low-layer communication module is ready for communication			6	s
T_conn_max_comm	Time after plug-in until the low-layer communication module is ready for communication			8	s
T_conn_resetup	Time to resetup the matching process after a loss of communication	15			s
T_vald_detect_time	Time to detect a variation of the state on EVSE side			200	ms
TP_EV_vald_state_duration	Duration of each state B or C within the BCB-Toggle	200		400	ms
TP_EV_vald_toggle	Duration of BCB-Toggle sequence	600		3 500	ms
TT_EVSE_vald_toggle	Timeout timer for the EVSE to stop monitoring control pilot for BCB-Toggle. Value comes from CM_VALIDATE.REQ			3 500	ms
TP_match_leave	Maximum time to leave the logical network			1	s
T_step_EF	Time to stay at E/F state	4			s

[V2G3-M08-02] Any successful matching process shall reset all the timeout timers and reset the retry_counters.

9 Matching EV — EVSE process

9.1 Overview

A unique matching between the EV and a specific charge coupler of the EVSE is necessary for most of the use cases. After the matching process, which is defined within this Clause, upper layers are able to proceed their binding process. Interfaces related to data link status between the layers are defined in [Clause 12](#). Depending on the communication signal paths, the matching process depends on the infrastructure topology.

Under some technical conditions, the matching process might render ambiguous results. In this case, an additional validation process based on a signalling through the control pilot line can be necessary to confirm the matching.

[Figure 10](#) gives a generic overview of the matching process. The full description is given in the corresponding annex.

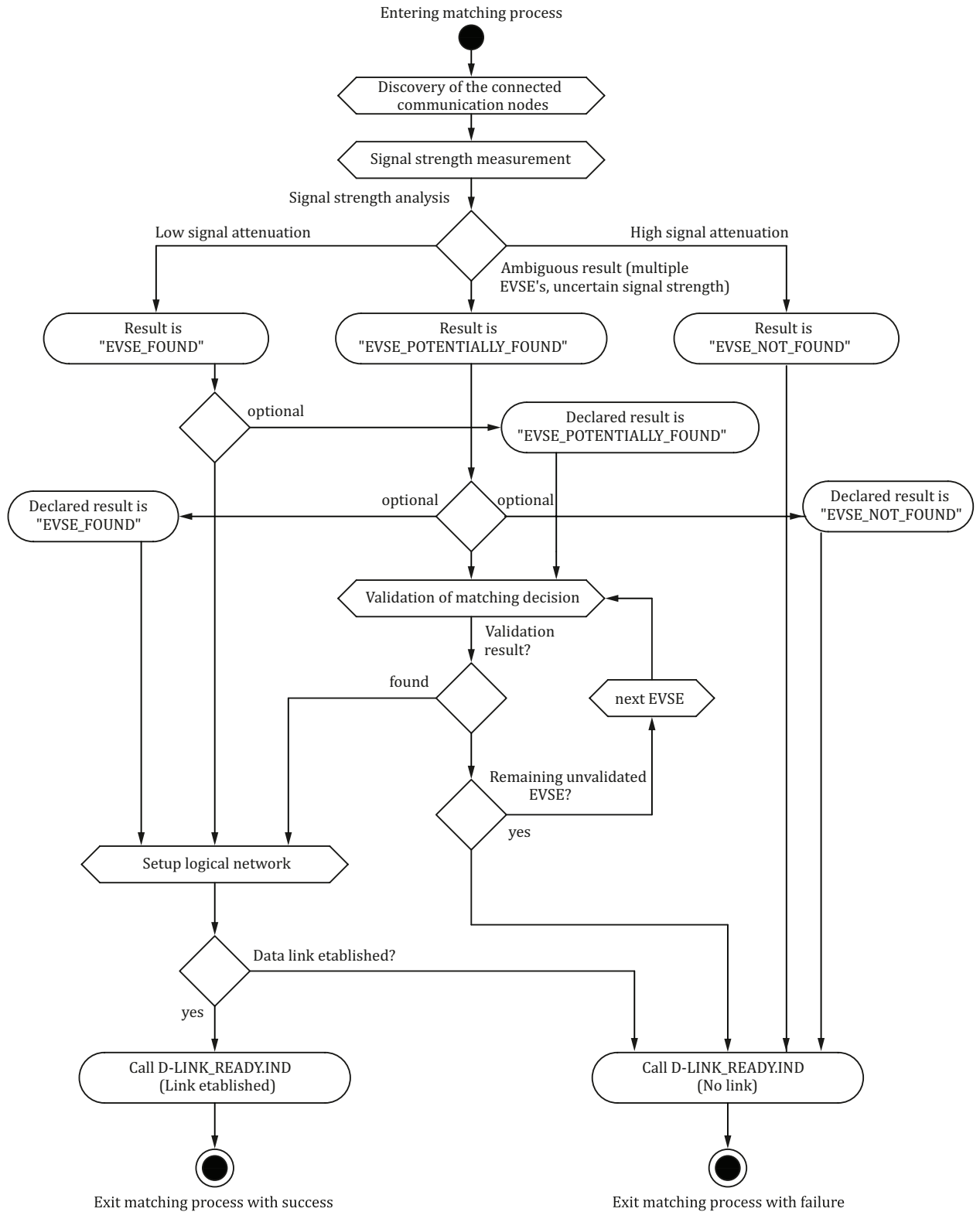

NOTE Error handling for Matching Process is not shown in this figure. See [A.9.8](#).

Figure 10 — EV point of view

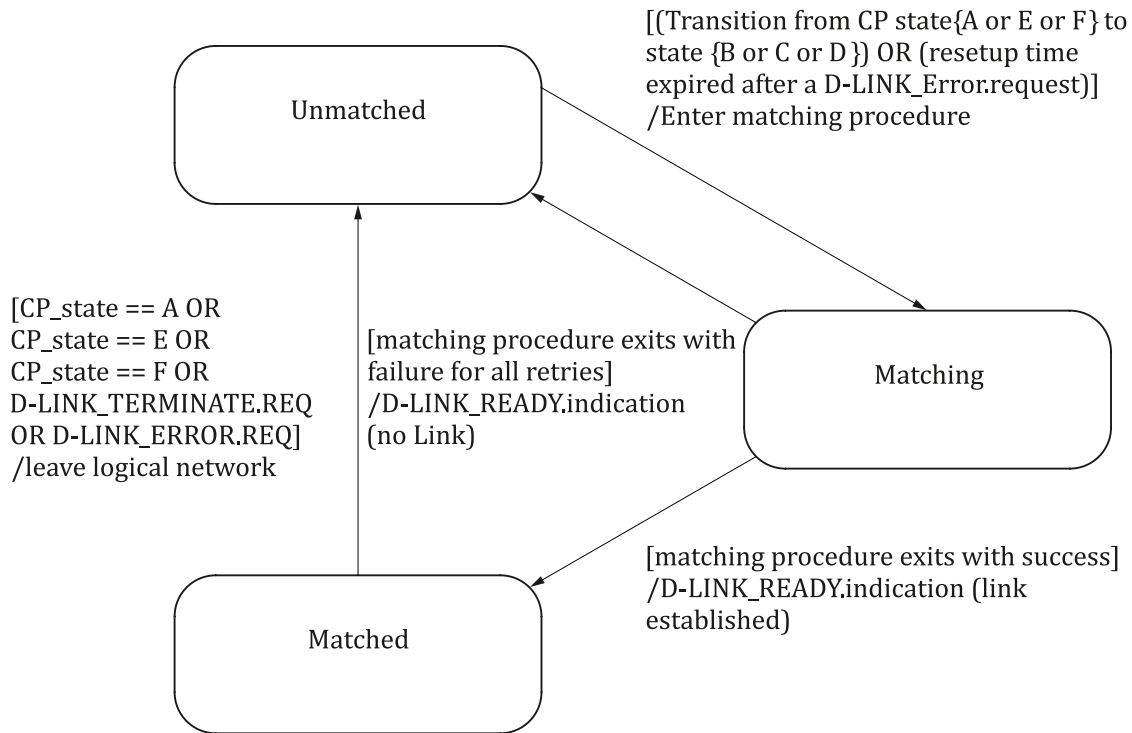

Figure 11 — Matching state machine

Figure 11 shows a high-level overview of the matching process. The default state of a PLC node at plug-in is “Unmatched”. A control pilot state change from state A, E or F to B, C or D triggers the matching process (state “Matching” in Figure 11) which determines the correct EV-EVSE matching by signal strength measurement. A successful matching process leads to the state “Matched” in Figure 11.

Any transition from the state “Matching” triggers a call of the primitive D-LINK_READY.indication to indicate a successful or failed data-link setup.

Any loss of the control pilot or a request from HLE leads to a reset to state “Unmatched”.

9.2 Initialization of matching process

The first phase of the matching process is called initialization of matching process. During this phase, the node is configured in order to enhance the matching process.

9.3 Discovery of the connected low-layer communication module

During the discovery process, the EV determines which EVSE is directly connected to its cable assembly.

The method is based on a measurement of the signal strength. The EV will discover all the communication nodes in range, measure, and compare signal strengths and will choose the communication nodes. See the corresponding annexes for more details.

[V2G3-M09-01] The EVSE shall be able to handle at least C_EVSE_match_parallel processes in parallel to be able to serve multiple matching processes in case of crosstalk.

NOTE 1 In case multiple EVs plug in at the same time, an EVSE has to handle multiple matching processes coming from direct and also crosstalked PLC signals.

[V2G3-M09-02] All [ISO-3] communication nodes in the network shall be compliant with a method of measurement based on the signal strength.

- [V2G3-M09-03]** Only EV communication nodes shall send requests based on this signal strength method.
- [V2G3-M09-04]** Only EVSE communication nodes shall answer to the requests based on this signal strength measurement.
- [V2G3-M09-05]** The signal strength measurement shall be concluded by the following:
- EVSE_FOUND: signal strength measurement confirms the physical matching;
 - EVSE_POTENTIALLY_FOUND: signal strength measurement does not give a distinct physical matching, validation might be required;
 - EVSE_NOT_FOUND: signal strength measurement confirms that no physical matching exists.

NOTE 2 The exact usage of the terms “EVSE_FOUND”, “EVSE_POTENTIALLY_FOUND”, and “EVSE_NOT_FOUND” are in the corresponding annexes.

According to the use-cases, each EVCC may consider the status “EVSE_POTENTIALLY_FOUND” as “EVSE_FOUND” or “EVSE_NOT_FOUND”.

According to the use-cases, each EVCC may consider the status “EVSE_FOUND” or “EVSE_POTENTIALLY_FOUND” as only “EVSE_POTENTIALLY_FOUND”.

If the EV status is “EVSE_FOUND”, the validation process is optional.

9.4 Validation of matching decision

The validation of matching decision is a method to validate the signal strength measurement through an additional independent path, based on the hardwired control pilot line.

If a validation of matching decision is required to confirm that the EV is connected to the right low-layer communication module, the following requirements are considered as mandatory if validation of matching is supported.

NOTE To support a BCB-Toggle for Wake-up is mandatory on EVSE side.

After the signal strength measurement, the EV can decide on the basis of the results to request the EVSE for an additional validation process. As soon as the EVSE is ready to detect the control pilot line, the EV sends a random timer value TP_EV_vald_toggle to the EVSE. After sending the message, the EV switches the control pilot state in the sequence B-C-B. This switching sequence is called BCB-Toggle in the following.

According to the EVSE architecture, the EVSE can answer to the request by the following certain states.

- “Not Required” state: This is just a recommendation from the EVSE, the EV decides either to follow the EVSE recommendation and to skip the validation process or to continue the process and to perform the validation process.
- “Failure” state: This is an indication from the EVSE that it does not support the validation process. The EV decides to either terminate the matching process with the current EVSE and go on with the next EVSE or to skip the validation process with the current EVSE.
- “Ready” state: This is an indication from the EVSE that it does support the validation process and is ready to continue the validation process.

In case of a performed validation process, the EV performs multiple BCB-Toggles during the time TP_EV_vald_toggle. The number of BCB-Toggles (C_EV_vald_nb_toggles) is chosen randomly in the available time.

At the end of the timer, the EVSE sends a frame with the number of BCB-Toggles seen on the Control Pilot line and waits for the decision value.

If supported, and in order to perform the validation process, EVs and EVSEs have to implement a method to validate the EV-EVSE connection based on the signal sequence “EV signal to the EVSE” defined in [IEC-1], Annex A.

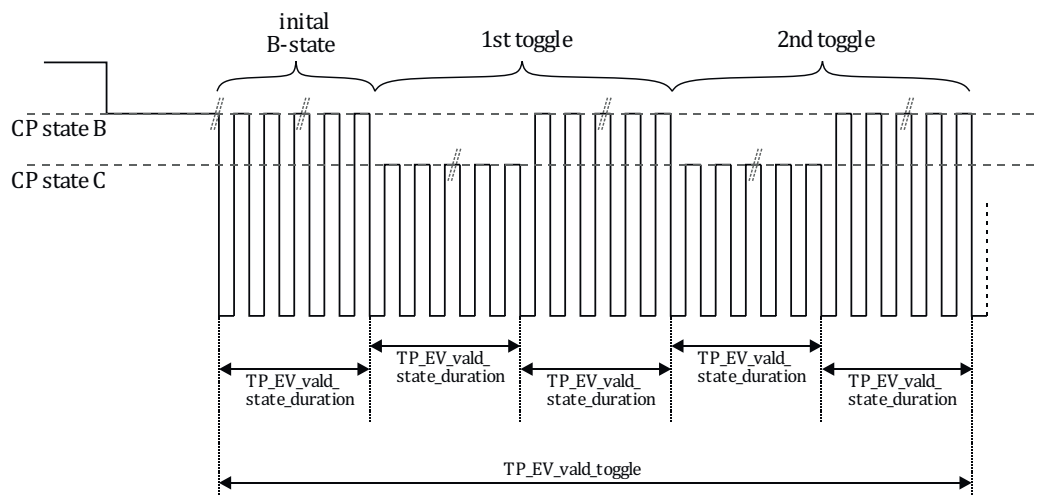

[V2G3-M09-06] In accordance with [IEC-1], the EV shall support the sequence of “BCB-Toggle” defined in Figure 12.

Figure 12 — Example of BCB-Toggle sequence with C_EV_vald_nb_toggles = 2 and active oscillator

[V2G3-M09-07] If the EV status is “EVSE_POTENTIALLY_FOUND”, the EV shall start the validation process. According to the grid architecture, the EVSE can inform the EV that it is allowed to abort the validation process. In such a case, the EV has the option to skip the validation process.

[V2G3-M09-08] According to its implementation, the EVSE can inform the EV that it does not support the validation process. The EV decides to either terminate the matching process with the current EVSE and go on with the next EVSE or to skip the validation process with the current EVSE.

[V2G3-M09-09] Since the communication node on EV side concludes the signal strength measurement, the communication node on EV side shall also conclude this mechanism. This method shall be concluded by

- EVSE_FOUND
- EVSE_NOT_FOUND.

NOTE At this stage, the validation is physically performed with the control pilot line. The “EVSE_POTENTIALLY_FOUND” state is not possible.

The following requirements only apply in case both the EV and the EVSE support the validation process:

[V2G3-M09-10] The EVSE shall be able to detect a state variation on the control pilot line within T_vald_detect_time.

[V2G3-M09-11] The duration of each state during the BCB-Toggle sequence is defined as TP_EV_vald_state_duration.

[V2G3-M09-12] Both EV and EVSE shall support a set of messages to exchange the number of BCB-Toggles, using the messages defined in dedicated annexes.

- [V2G3-M09-13]** In the case an EVSE receives a validation request while it is still in a validation process with another EV, it shall give a negative response to incoming requests.
- [V2G3-M09-14]** The EV shall perform C_EV_vald_nb_toggles BCB-Toggle(s) during the validation process and shall adjust the TP_EV_vald_toggle in coherence with the number of BCB-Toggles.
- [V2G3-M09-15]** The control pilot duty cycle shall not have an impact on the validation process.

9.5 Set-up a logical network

According to the low-layer communication technology, a logical network might have to be built in order to enhance the communication.

- [V2G3-M09-16]** As soon as the EV has successfully joined the logical network of the EVSE, both entities are in the status “Matched”. The communication node shall inform HLE through the D-LINK_READY.indication (link established) that HLE’s binding process can begin.

9.6 Leave the logical network

- [V2G3-M09-17]** With receiving a D-LINK_TERMINATE.request from HLE, the communication node shall leave the logical network within TP_match_leave. All parameters related to the current link shall be set to the default value and shall change to the status “Unmatched”.
- [V2G3-M09-18]** When the low-layer communication module leaves the logical network, it shall inform HLE through the D-LINK_READY.indication (no link).

9.7 Error handling

- [V2G3-M09-19]** In the following cases, the communication node shall leave the logical network within TP_match_leave. All parameters related to the current link shall be set to the default value and shall change to the status “Unmatched”.
- The state A is detected on EVSE side
 - The state E is detected on EV side

NOTE Additional errors are defined in the corresponding annexes.

10 EMC requirements

Requirements are defined in [IEC-21] and [IEC-22].

Technology related EMC requirements are defined in the corresponding annexes.

11 Signal coupling

The signal coupling, as well as additional requirements regarding the physical layer, the MAC layer and the interface with the network layer are defined within the corresponding annexes.

12 Layer 2 interfaces

12.1 Overview

This Clause describes the terminology primitives used within this part of ISO 15118. It is for explanation and for definition of a unique terminology only. This terminology is implementation independent.

As shown in [Figure 2](#), the definition of the data link layer provides the following two interfaces to higher layers.

- Data SAP is the interface between the communication technology and the layer 3 (e.g. IPv6).
- The data link control SAP provides link status information, error information, control functionality and is located between the connection coordination and higher layers.

12.2 Data SAP

The data SAP interfaces higher layer data to a low-layer communication technologies data link layer.

12.3 Data link control SAP to layer 3

These primitives are defined according to *[ISO-2]*.

[V2G3-M12-01] The D-LINK_READY.indication shall inform higher layers about a change of communication link status. This indication shall be sent with any change in link status. The values of the D-LINK_READY status are independent of the states of the control pilot signal.

Table 4 — D-LINK_READY.indication primitive

Primitive	D-LINK_READY.indication
Entity to support	EV, EVSE
Parameter name	Description
D-LINKSTATUS	Status of communication link: — no link — link established

The D-LINK_TERMINATE.request requests lower layers to terminate the data link.

Table 5 — D-LINK_TERMINATE.request primitive

Primitive	D-LINK_TERMINATE.request
Entity to support	EV, EVSE

The D-LINK_ERROR.request requests lower layers to terminate the data link and restart the matching process by a control pilot transition through state E.

Table 6 — D-LINK_ERROR.request primitive

Primitive	D-LINK_ERROR.request
Entity to support	EVSE

The D-LINK_PAUSE.request requests lower layers to enter a power saving mode. While being in this mode, the state will be kept to “Matched”.

Table 7 — D-LINK_PAUSE.request primitive

Primitive	D-LINK_PAUSE.request
Entity to support	EV, EVSE

Annex A (normative)

HomePlug Green PHY on control pilot line

A.1 Introduction

This Annex describes all requirements for the HomePlug Green PHY Technology on control pilot line. All requirements of this Annex are mandatory.

If not specifically indicated, both generic and technology-dependent requirements are mandatory.

A.2 Normative references relevant for Annex A

The following referenced documents are indispensable for the application of this Annex. For dated references, only the edition cited applies. For undated references, the latest edition of the referenced document (including any amendments) applies.

IEEE 1901, *Standard for Broadband over Power Line Networks: Medium Access Control and Physical Layer Specifications, release version of 2011*

HomePlug Green PHY Specification

A.3 Terms and definitions

For the purposes of this document, the following terms and definitions in addition to the terms and definitions given in [Clause 3](#).

A.3.1

amplitude map

specifies a transmit power-reduction factor for each subcarrier related to the Tone Mask

A.3.2

central coordinator

manager of a HomePlug Green PHY network

A.3.3

channel access priority

CAP

method to prioritize the channel access

Note 1 to entry: See [HPGP].

A.3.4

inter system protocol

enables various Broadband Power Line systems to share power line communication resources in time (time domain multiplex), in frequency (frequency domain multiplex), or both

Note 1 to entry: For more information, refer to [IEEE].

A.3.5

management message entry

MME

messages exchanged between PLC nodes or a PLC node and higher layers for control purposes

A.3.6

QPSK modulation

phase modulation technique that transmits two bits in four modulation states

A.3.7

ROBO mode

communication mode which uses QPSK only for carrier modulation within the orthogonal frequency division multiplexing (OFDM) to achieve higher robustness in transmission

Note 1 to entry: The ROBO mode can be set to three different performance levels: Mini-ROBO, Standard ROBO and high Speed ROBO

A.3.8

signal level attenuation characterization

SLAC

protocol to measure the signal strength of a signal between HomePlug Green PHY stations

A.3.9

tone mask

defines the set of tones (or carriers) that can be used in a given regulatory jurisdiction or given application

A.4 Symbols and abbreviated terms

CAP	Channel Access Priority
CCo	Central Coordinator
HPGP	HomePlug Green PHY
ISP	Intersystem Protocol
MME	Management Message Entry
PE	Protective Earth
PLC	Power Line Communication
QPSK	Quadrature Phase Shift Keying
SLAC	Signal Level Attenuation Characterization

A.5 Conventions applicable for Annex A

All conventions are described in the [Clause 5](#) of this part of ISO 15118 and are used in all annexes.

In addition to the normative references defined in [5.3](#), the following references to normative document are used in this Annex:

[IEEE]	IEEE 1901
[HPGP]	HomePlug Green PHY Specification

A.6 System architecture

A.6.1 Layers overview

[Figure 2](#) gives an overview of the structure.

As shown in [Figure 2](#), the definition of the data link layer provides two interfaces to higher layers; the ETH SAP and the data link control SAP.

A.6.1.1 Communication media

In this Annex, the communication media block as shown in [Figure 2](#) is the control pilot line ([IEC-1], Annex A).

A.6.1.2 Data SAP

The data SAP is the ETH SAP. The ETH SAP is completely covered by the [HPGP].

Due to the convergence layer, the data link layer of HomePlug Green PHY provides an Ethernet II-class SAP to higher layers.

This SAP supports applications using Ethernet II-class packets, including IEEE 802.3 with or without IEEE 802.2 (LLC), IEEE 802.1H (SNAP) extensions, and/or VLAN tagging.

The data link control SAP indicates link status and error information to higher layers and is provided by the connection coordination entity.

A.6.1.3 Signal coupling

The signal coupling interface is described in [A.11](#).

A.6.1.4 MAC/PHY stack

The highlighted entities of [Figure 2](#) represent the whole HomePlug Green PHY MAC and PHY layer and are covered by [HPGP]. The convergence layer adapts the generic HomePlug Green PHY MAC to an IEEE 802.3 Ethernet II-class interface through the ETH SAP. The control SAP provides a control interface to access HomePlug GreenPHY specific data and configuration for network management, including encryption key management, SLAC services, and link status information.

A.6.1.5 Connection coordination

There are no additional requirements for the technology.

A.6.2 Definition of high-level communication and basic signalling

There are no additional requirements for the technology.

A.6.3 Identification requirements

There are no additional requirements for the technology.

A.6.4 System requirements

There are no additional requirements for the technology.

A.6.5 Configuration of a PLC module

This subclause is a summary of some key points of HomePlug Green PHY technology that this part of ISO 15118 requires.

The physical layer of the HomePlug Green PHY technology is fully described in [HPGP].

A.6.5.1 Shared bandwidth mechanisms

NOTE 1 Coexistence mechanisms with other HomePlug technologies are addressed in [HPGP].

A.6.5.1.1 ISP

[HPGP] implements the ISP as a coexistence mechanism. The ISP, defined by [IEEE], allows coexistence between devices that implement non-interoperable protocols. Using ISP, 1901 access, 1901 wavelet, 1901 FFT, LRWBS, and ITU-T G.hn, devices are able to coexist.

[V2G3-A06-01] The low-layer communication module on the EVSE side shall be capable to detect the zero cross of the AC line cycle to support coexistence functionality.

NOTE 2 Coexistence mechanisms with other technologies, covered by [IEEE], are a requirement in [HPGP].

A.6.5.1.2 Coexistence with HomePlug AV technologies

In addition to the coexistence mechanisms with other HomePlug technologies, there is a specificity regarding the HomePlug AV technology: In case of coexistence with a fully loaded HomePlug AV, the HomePlug Green PHY may be limited to 7 % in time. This can affect the data rate.

A.6.5.2 Functional description

After this process, the low-layer communication module is configured to a defined state. This configuration is a precondition for the matching process and is done latest with entering the matching process.

[V2G3-A06-02] The low-layer communication module on the EV side shall be configured in order to never become the CCo.

[V2G3-A06-03] The low-layer communication module on the EVSE side shall be configured in order to always be the CCo.

For the configuration of the CCo mode the APCM_SET_CCo.REQ primitive defined in Clause “Control SAP Service” of the [HPGP] may be used.

[V2G3-A06-04] To speed up the matching process, the low-layer communication module shall be configured to use CAP3 priority for all frames related to the matching process.

[V2G3-A06-05] The low-layer communication module on the EV side shall never respond to the following MMEs:

- CM_SLAC_PARM.REQ;
- CM_START_ATTEN_CHAR.IND;
- CM_MNBC_SOUND.IND;
- CM_ATTEN_CHAR.RSP;

- CM_VALIDATE.REQ;
- CM_SLAC_MATCH.REQ.

A.7 Connection coordination

There are no additional requirements for the technology.

A.8 Timings and constants

This Clause summarizes all timings used in this Annex.

[V2G3-A08-01] All low-layer communication modules shall comply with [Table A.1](#).

Table A.1 — Timing and constant values

Parameter	Description	Min	Typical	Max	Unit
C_EV_match_MNBC	Number of M-Sounds sent for the SLAC		10		nbr
C_EV_match_retry	Number of retries of the corresponding message within the matching process			2	nbr
C_EV_match_signalattn_direct	Lower threshold for the signal strength measurement		10		dB
C_EV_match_signalattn_indirect	Higher threshold for the signal strength measurement		20		dB
C_EV_start_attn_char_inde	Number of CM_START_ATTEN_CHAR.INDs sent by the EV		3		nbr
TP_amp_map_exchange	Performance timer for the start of an AMP MAP Exchange Either the EV or the EVSE shall send a CM_AMP_MAP.REQ within the max value of this timer after link is detected in order to trigger an AMP MAP Exchange.			100	ms
TP_EV_batch_msg_interval	Interval between two CM_START_ATTEN_CHAR.IND or CM_MNBC_SOUND.IND messages	20		50	ms
TP_EV_match_session	Performance time for the EV to start validation or SLAC_MATCH after sending CM_ATTEN_CHAR.RSP			500	ms
TP_EV_SLAC_init	Time between plug-in (state B detected) or wake-up and start of matching by the EV			10	s
TP_EVSE_avg_attn_calc	Performance time for the EVSE to calculate the average attenuation profile after reception of all M-SOUNDS or after TT_EVSE_match_MNBC has expired			100	ms
TP_link_ready_notification		0,2		1	s
TP_match_response	General performance time for a response to a request			100	ms

Table A.1 (continued)

Parameter	Description	Min	Typical	Max	Unit
TP_match_sequence	General performance time for subsequent requests after a response to previous request has been received			100	ms
TT_amp_map_exchange	Timeout timer that runs on both EV and EVSE side after link is detected. If an EV or EVSE does not want to start an AMP MAP Exchange and no request is received by the other side within the timeout value of this timer, then it is to be assumed that no AMP MAP Exchange will take place and a D-LINK_READY.indication is to be sent to the HLE.			200	ms
TT_EV_atten_results	Time the EV shall wait for CM_ATTEN_CHAR.IND messages from EVSEs. Timer starts with the sending of the first CM_START_ATTEN_CHAR.IND			1 200	ms
TT_EVSE_match_MNBC	Timeout on the EVSE side that triggers the calculation of the average attenuation profile	600	600		ms
TT_EVSE_match_session	Maximum time from the expiration of TT_EVSE_match_MNBC and the reception of either CM_VALIDATE.REQ or CM_SLAC_MATCH.REQ			10	s
TT_EVSE_SLAC_init	Time between detecting state B and receiving CM_SLAC_PARM.REQ on the EVSE side	20		50	s
TT_match_join	Maximum time between CM_SLAC_MATCH.CNF and link establishment. If there is no link after this timeout expires, EV retries matching process and EVSE resets its state machine			12	s
TT_match_response	Time that the EV/EVSE shall wait for a response from the EVSE/EV			200	ms
TT_match_sequence	Time that the EVSE/EV shall wait for a request from the EV/EVSE			400	ms
TT_matching_repetition	Time duration for repetitions of the matching process when an error occurs	10			s
TT_matching_rate	Time to wait for a repetition of the whole matching process after a failed matching process	400			ms

A.9 Matching EV – EVSE process

[V2G3-A09-01] The matching process shall base on the messages defined in [HPGP].

[V2G3-A09-02] The configuration of the low-layer communication module as described in A.4.5 shall be done prior to entering the matching process.

[Figures A.1 and A.2](#) outlines the complete sequence of the matching process. It shows the sequence to follow, from the discovery of the other low-layer communication modules to the start of the nominal communication.

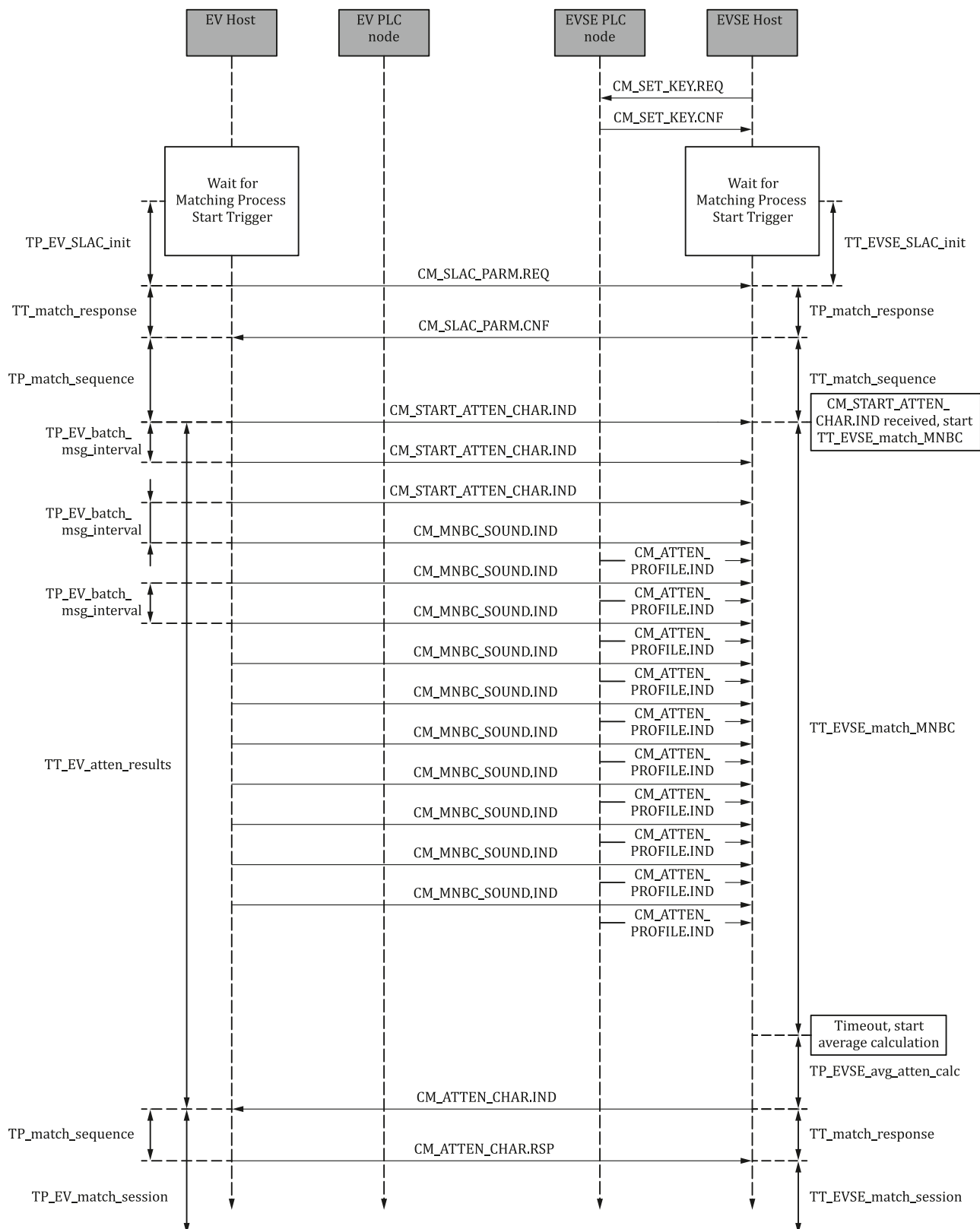

Figure A.1 — Sequence chart of HomePlug Green PHY matching process (part 1)

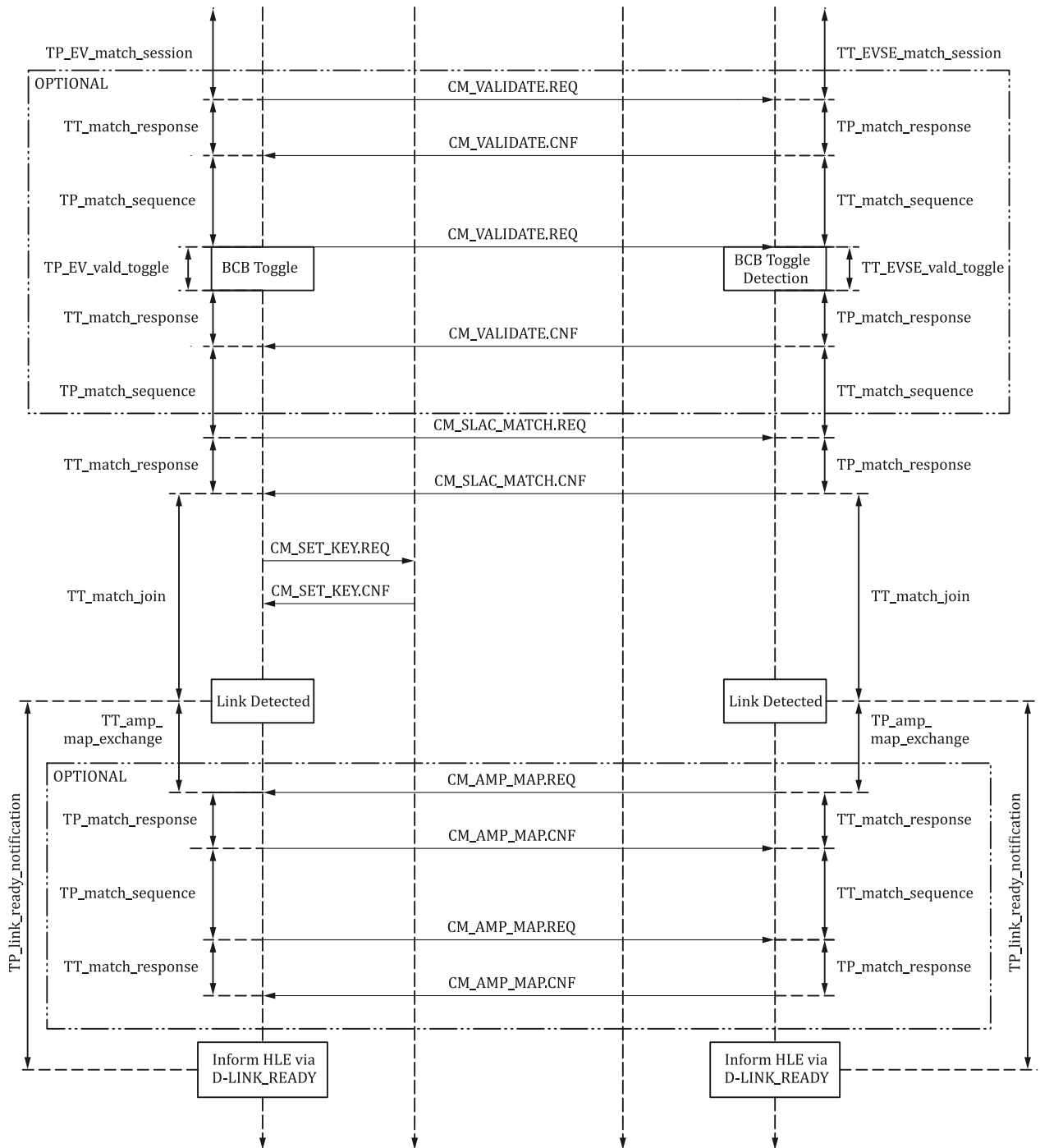

Figure A.2 — Sequence chart of HomePlug Green PHY matching process (part 2)

A.9.1 Signal strength measurement – parameter exchange

A.9.1.1 Functional description

Before the signal strength measurement starts, the EV broadcasts the parameters to be used for the following signal strength measurement sequence by means of the message CM_SLAC_PARM.REQ. Any

unmatched EVSE which receives the parameter exchange broadcast sends a response to the EV by means of the message CM_SLAC_PARM.CNF.

[V2G3-A09-03] A SLAC request shall only be responded by EVSEs low-layer communication module if all the following conditions are fulfilled:

- EVSE is connected to an EV, detected by a valid control pilot;
- EVSE is in “Unmatched” state.

A.9.1.2 Description of involved MMEs

[V2G3-A09-04] The MMEs for the parameter exchange shall be used with the following content and be sent as Ethernet unicast/broadcast messages as defined.

Table A.2 — Involved MMEs for parameters exchange

MME	Field	Octet No.	Field Size (Octets)	Value	Definition
CM_SLAC_PARM.REQ Broadcast	APPLICATION_TYPE	0	1	0x00	Fixed value indicating “PEV-EVSE matching”
	SECURITY_TYPE	1	1	0x00	Fixed value indicating “No Security”
	RunID	2 to 9	8	variable	Identifier for a matching run, randomly chosen by the EV for each CM_SLAC_PARM.REQ message and constant for all following messages of the same run
CM_SLAC_PARM.CNF Unicast	M-SOUND_TARGET	0 to 5	6	0xFFFFFFFFFFFF	Fixed value indicating that M-Sounds to be sent as Ethernet broadcast
	NUM_SOUNDS	6	1	C_EV_match_MNBC	Number of expected M-Sounds transmitted by the GP station during the SLAC process
	Time_Out	7	1	0x06	Duration TT_EVSE_match_MNBC while the EVSE receives incoming M-SOUNDS after a CM_START_ATTEN_CHAR.IND
	RESP_TYPE	8	1	0x01	Fixed value indicating “Other GP station”
	FORWARDING_STA	9 to 14	6	EV Host MAC address	The destination of SLAC results is always the EV Host
	APPLICATION_TYPE	15	1	0x00	Fixed value indicating “PEV-EVSE Matching”
	SECURITY_TYPE	16	1	0x00	Fixed value indicating “No Security”
	RunID	17 to 24	8	variable	This value shall be the same as the one sent in the CM_SLAC_PARM.REQ message by the EV

A.9.1.3 Timing constrains and error handling

A.9.1.3.1 Sequence chart

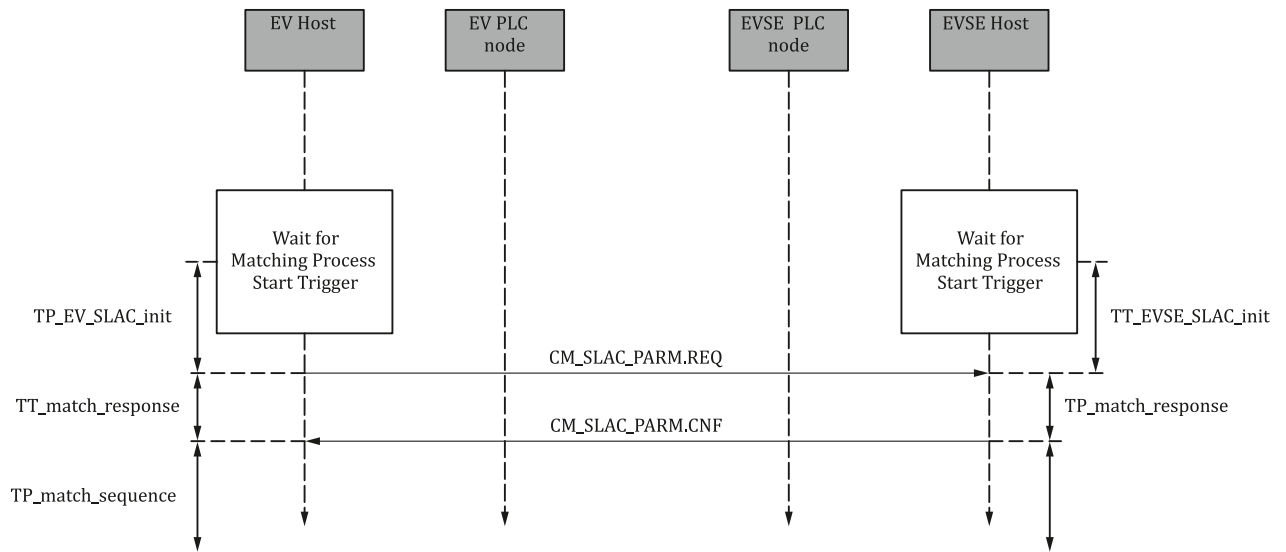

Figure A.3 — Sequence chart of signal strength measurement — Parameter exchange

A.9.1.3.2 EV side

- [V2G3-A09-05] The EV shall send a CM_SLAC_PARM.REQ within TP_EV_SLAC_init time window.
- [V2G3-A09-06] The start condition of the TP_EV_SLAC_init timer shall be the trigger of the matching process defined in [6.4.3.2](#).
- [V2G3-A09-07] In the SLAC parameter exchange phase, the EV shall send a CM_SLAC_PARM.REQ and wait for the maximum value of TT_match_response for CM_SLAC_PARM.CNFs from potential EVSEs.
- [V2G3-A09-08] The start condition of TT_match_response shall be the transmission of CM_SLAC_PARM.REQ.
- [V2G3-A09-09] If the EV receives a CM_SLAC_PARM.CNF with invalid content, it shall be ignored. Content which deviate from the MME definition in [Table A.2](#) is invalid.
- [V2G3-A09-10] If no valid CM_SLAC_PARM.CNF arrives at the EV when TT_match_response expires, the EV shall retransmit the request and wait again for TT_match_response. The total number of retries is given by C_EV_match_retry. If C_EV_match_retry is reached, the matching process shall be considered as FAILED.

A.9.1.3.3 EVSE side

- [V2G3-A09-11] As long as the TT_EVSE_SLAC_init timer is not expired, the EVSE shall answer to valid CM_SLAC_PARM.REQs.
- [V2G3-A09-12] The start condition of the timer TT_EVSE_SLAC_init shall be the trigger of the matching process defined in [Clause 6](#).
- [V2G3-A09-13] If no valid CM_SLAC_PARM.REQ arrives within the Max(TT_EVSE_SLAC_init), the EVSE shall consider that no SLAC will be performed.

- [V2G3-A09-14] If the EVSE receives a CM_SLAC_PARM.REQ with invalid content, the EVSE shall ignore it and shall not stop the timeout timer TT_EVSE_SLAC_init. Content which deviate from the MME definition in [Table A.2](#) is invalid.
- [V2G3-A09-15] When receiving a CM_SLAC_PARM.REQ, the EVSE shall answer by sending a CM_SLAC_PARM.CNF response within TP_match_response.
- [V2G3-A09-16] If, during a matching process, the EVSE receives a CM_SLAC_PARM.REQ from the EV which participates in the on-going matching process, the EVSE shall restart its state machine and reply to this request because it shall be considered as a new retry by the EV.

A.9.2 Signal strength measurement

A.9.2.1 Functional description

By means of the signal strength measurement, the EV has to determine which counterpart EVSE nodes are available and which one is the right one to connect to. Therefore, the EVSE measures the attenuation of the signal coming from the EV for different groups of frequencies and reports the signal strength back to the EV. Based on the reports, the EV determines the EVSE which is connected in a direct way.

After the parameter exchange, the EV starts the signal strength measurement process by sending C_EV_start_atten_char_inds times the message CM_START_ATTEN_CHAR.IND followed by C_EV_match_MNBC number of M-SOUNDS. Based on these M-SOUNDS, all potential EVSEs calculate the signal strength and send back the measurement result by means of the CM_ATTEN_CHAR.IND message. Each CM_ATTEN_CHAR.IND is confirmed by the EV by an individual CM_ATTEN_CHAR.RSP.

The signal strength measurement method to be used is the SLAC defined in the *[HPGP]*.

- [V2G3-A09-17] The SLAC implementation of the low-layer communication module on EV and EVSE side shall be compliant with the messages defined in *[HPGP]*.
- [V2G3-A09-18] The low-layer communication module on EV and EVSE sides shall be compliant with the sequence diagram of [Figure A.1](#).
- [V2G3-A09-19] The ATTEN_PROFILE within the message CM_ATTEN_CHAR.IND shall be calculated by arithmetic mean of the ATTEN_PROFILE of the CM_ATTEN_PROFILE.IND of previous M-SOUNDS corrected by the attenuation of the receive path AttnRx-EVSE as described in [A.9.4.1](#).
- [V2G3-A09-20] The Average_Attenuation used for matching decision shall be calculated by the arithmetic mean of all groups in the CM_ATTEN_CHAR.IND message. To take implementation specifics into account, a weighted average may be used. When using a weighted average, the sum of the weights of all groups shall be one.
- [V2G3-A09-21] According to the result of the SLAC process, the low-layer communication module on the EV side shall send its decision using the following relevant message after the CM_ATTEN_CHAR.IND message:
- if EV_Discovering_Status = EVSE_FOUND, the low-layer communication module shall inform the corresponding EVSE by continuing the message flow as described in A.7.4;

- if EV_Discovering_Status = EVSE_POTENTIALLY_FOUND, the low-layer communication module shall inform the most probable EVSE by continuing the message flow as described in A.7.3;
- if EV_Discovering_Status = EVSE_NOT_FOUND, the matching process shall be considered as FAILED.

[V2G3-A09-22] Based on the signal attenuation read by the “CM_ATTEN_CHAR.IND” message, the EV_Discovery_Status shall be set according to [Table A.3](#).

Table A.3 — EV_Discovering_Status definition

Status	Average_Attenuation		Description
	From	To	
EVSE_FOUND	-	C_EV_match_signal- attn_direct	The EVSE is identified without any doubt
EVSE_POTENTIALLY_FOUND	C_EV_match_signalattn_ direct	C_EV_match_signalattn_ indirect	One or several EVSEs are identified. The next step of the matching process will allow deciding if the most probable candidate is the connected EVSE.
EVSE_NOT_FOUND	C_EV_match_signalattn_ indirect	-	No direct connected EVSE is found

A.9.2.2 Description of involved MMEs

[V2G3-A09-23] For the SLAC process, the low-layer communication module shall use the set of MMEs defined in [Figure A.1](#). The parameters to be used within the MMEs are defined in [Table A.4](#).

[V2G3-A09-24] The Ethernet Destination MAC address field shall be filled either as Broadcast or Unicast, as defined in [Table A.4](#).

Table A.4 — MMEs parameters definition for SLAC

MME	Field	Octet no.	Field size (Octets)	Value	Definition
CM_START_ATTEN_CHAR.IND broadcast	APPLICATION_TYPE	0	1	0x00	Fixed value indicating “PEV-EVSE Matching”
	SECURITY_TYPE	1	1	0x00	Fixed value indicating “No Security”
	NUM_SOUNDS	2	1	C_EV_match_MNBC	Number of M-Sounds transmitted by the GP station during the SLAC process
	Time_Out	3	1	TT_EVSE_match_MNBC	Max. time window within the M-Sounds are sent
	RESP_TYPE	4	1	0x01	Fixed value indicating “other Green PHY station”
	FORWARDING_STA	5 to 10	6	EV Host MAC address	The destination of SLAC results is always the EV Host
	RunID	11 to 18	8	variable	This value shall be the same as the one sent in the CM_SLAC_PARM.REQ message by the EV

Table A.4 (continued)

MME	Field	Octet no.	Field size (Octets)	Value	Definition
CM_MNBC_SOUND.IND broadcast	APPLICATION_TYPE	0	1	0x00	Fixed value indicating "PEV-EVSE Matching"
	SECURITY_TYPE	1	1	0x00	Fixed value indicating "No Security"
	SenderID	2 to 18	17	0x00	-
	Cnt	19	1	variable	Countdown counter for number of sounds remaining after the certain message
	RunID	20 to 27	8	-	This value shall be the same as the one sent in the CM_SLAC_PARM.REQ message by the EV
	RSVD	28 to 35	8	0x00	reserved
	Rnd	36 to 51	16	variable	Random value
CM_ATTEN_CHAR.IND unicast	APPLICATION_TYPE	0	1	0x00	Fixed value indicating "PEV-EVSE matching"
	SECURITY_TYPE	1	1	0x00	Fixed value indicating "No Security"
	SOURCE_ADDRESS	2 to 7	6	MAC address of the EV Host	MAC address of the EV Host which initiates the SLAC process
	RunID	8 to 15	8	variable	This value shall be the same as the one sent in the CM_SLAC_PARM.REQ message by the EV
	SOURCE_ID	16 to 32	17	0x00	-
	RESP_ID	33 to 49	17	0x00	-
	NumSounds	50	1	variable	Number of M-Sounds used for generation of the ATTEN_PROFILE
	ATTEN_PROFILE	51 to 109	59	Attenuation value	Signal level attenuation (Field format in Table "ATTEN_PROFILE" of [HPGP])

Table A.4 (continued)

MME	Field	Octet no.	Field size (Octets)	Value	Definition
CM_ATTEN_CHAR.RSP Unicast	APPLICATION_TYPE	0	1	0x00	Fixed value indicating "PEV-EVSE Matching"
	SECURITY_TYPE	1	1	0x00	Fixed value indicating "No Security"
	SOURCE_ADDRESS	2 to 7	6	MAC address of the EV Host	MAC address of the EV which initiates the SLAC process
	RunID	8 to 15	8	variable	This value shall be the same as the one sent in the CM_SLAC_PARM.REQ message by the EV
	SOURCE_ID	16 to 32	17	0x00	-
	RESP_ID	33 to 49	17	0x00	-
	Result	50	1	0x00	Fixed value of 0x00 indicates a successful SLAC process
CM_ATTEN_PROFILE.IND	PEV MAC	0 to 5	6	MAC address of the EV Host	MAC address of EV Host
	NumGroups	6	1	0x3A	Number of OFDM carrier groups used for the SLAC signal characterization.
	RSVD	7	1	0x00	reserved
	AAG[1]	8	1	Attenuation value	Average Attenuation of Group 1
	...				
	AAG[58]	65	1	Attenuation value	Average Attenuation of Group 58

A.9.2.3 Timing constraints and error handling

A.9.2.3.1 Sequence chart

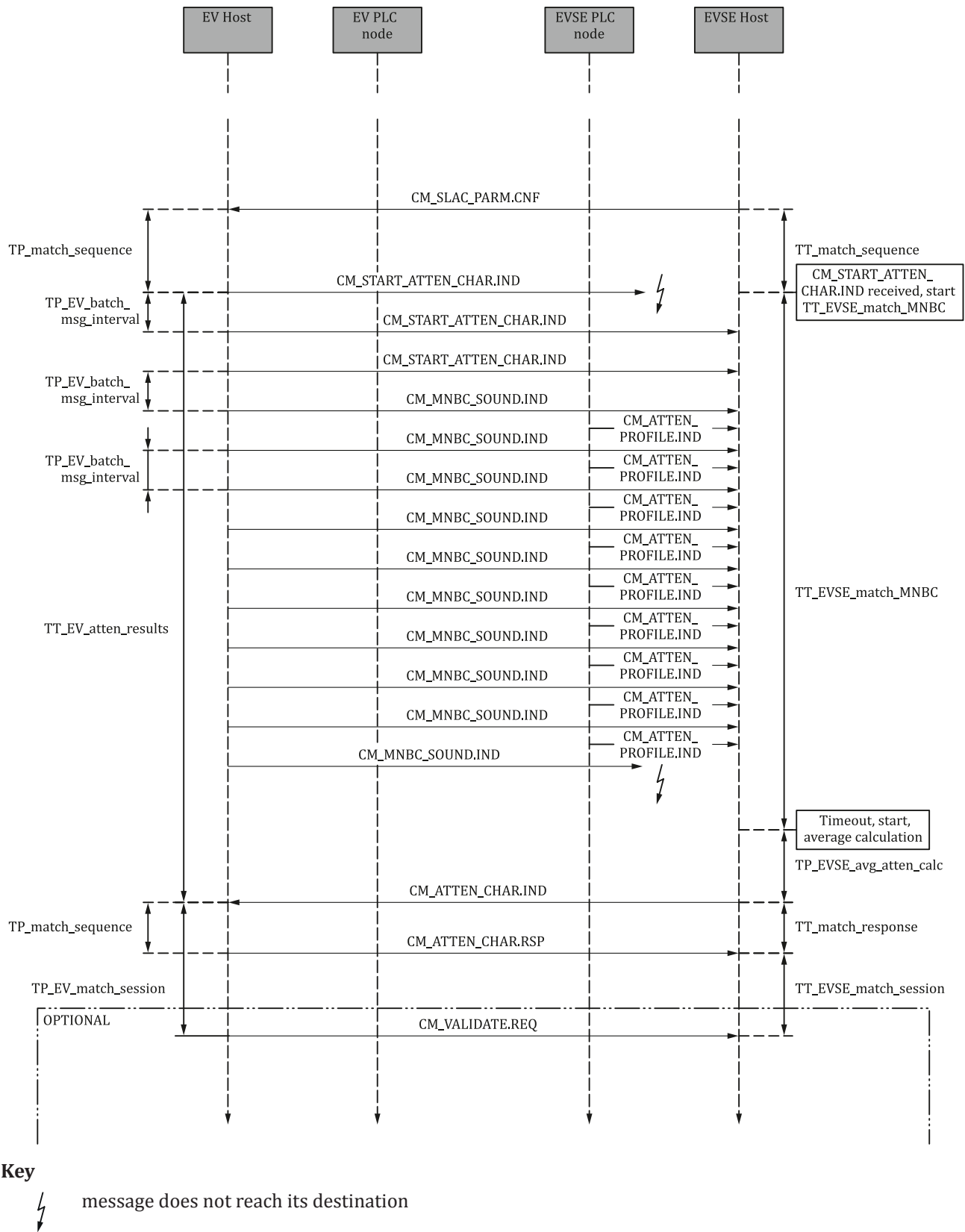

Figure A.4 — Sequence chart of signal strength measurement

A.9.2.3.2 EV side

- [V2G3-A09-25]** With receiving a CM_SLAC_PARM.CNF, the EV shall start the timer TP_match_sequence. When the TP_match_sequence timer expires, the EV shall send a sequence of C_EV_start_attn_char_inds CM_START_ATTEN_CHAR.IND messages.
- [V2G3-A09-26]** The time duration between consecutive CM_START_ATTEN_CHAR.IND messages shall be TP_EV_batch_msg_interval.
- [V2G3-A09-27]** After sending the last message of the CM_START_ATTEN_CHAR.IND message sequence, the EV shall wait for TP_EV_batch_msg_interval before starting the CM_MNBC_SOUND.IND message sequence.
- [V2G3-A09-28]** Within CM_MNBC_SOUND.IND message sequence, the EV shall transmit the CM_MNBC_SOUND.IND message C_EV_match_MNBC times. With each message, the counter field “cnt” shall be decremented.
- [V2G3-A09-29]** The time duration between consecutive CM_MNBC_SOUND.IND messages shall be TP_EV_batch_msg_interval.
- [V2G3-A09-30]** The EV shall start the timeout timer TT_EV_attn_results when sending the first CM_START_ATTEN_CHAR.IND.
- [V2G3-A09-31]** While the timer TT_EV_attn_results is running, the EV shall process incoming CM_ATTEN_CHAR.IND messages. If the CM_ATTEN_CHAR.IND messages from all EVSEs are received, which were recognized during the parameter exchange, the EV is allowed to stop the TT_EV_attn_results timer and continue the matching process. To be able to service also EVSEs which were not received during the parameter exchange, the EV may wait for incoming CM_ATTEN_CHAR.IND messages until the TT_EV_attn_results timer expires before continuing the matching process.
- [V2G3-A09-32]** If no CM_ATTEN_CHAR.IND is received before TT_EV_attn_results expires, the matching process shall be considered as FAILED.
- [V2G3-A09-33]** If a CM_ATTEN_CHAR.IND is received and its origin is an EVSE that has not sent a CM_SLAC_PARM.CNF before, the message shall be processed and not ignored.
- [V2G3-A09-34]** If the TT_EV_attn_results timer expires and not all anticipated responses are received, the EV shall continue the matching process.
- [V2G3-A09-35]** If the EV receives a CM_ATTEN_CHAR.IND with invalid content, it shall be ignored. Content which deviate from the MME definition in [Table A.4](#) is invalid.
- [V2G3-A09-36]** If the NUM_SOUNDS field in a CM_ATTEN_CHAR.IND is zero, then the ATTEN_PROFILE has no significance and the whole messages shall be ignored. It is up to the EV to decide what number of M-SOUNDS used for the attenuation profile is sufficient for its decision (i.e. whether to discard CM_ATTEN_CHAR.IND if NUM_SOUNDS is less than C_EV_match_MNBC).
- [V2G3-A09-37]** On reception of CM_ATTEN_CHAR.IND, the EV shall answer by sending the CM_ATTEN_CHAR.RSP within TP_match_sequence.
- [V2G3-A09-38]** After sending a CM_ATTEN_CHAR.RSP, the EV shall continue the matching process with the other EVSEs whose EV_Discovering_Status are “EVSE_FOUND” and/or “EVSE_POTENTIALLY_FOUND” by sending either a CM_SLAC_MATCH.REQ to the selected EVSE or a CM_VALIDATE.REQ to one of the potential EVSEs within TP_EV_match_session.

A.9.2.3.3 EVSE side

- [V2G3-A09-39] While sending the CM_SLAC_PARM.CNF in the parameter exchange sequence, the EVSE shall start a timer TT_match_sequence. The reception of a single valid CM_START_ATTEN_CHAR.IND message shall be sufficient to stop the timer TT_match_sequence.
- [V2G3-A09-40] If the EVSE has not received a CM_START_ATTEN_CHAR.IND within TT_match_sequence, the matching process shall be considered as FAILED.
- [V2G3-A09-41] If the EVSE receives a CM_START_ATTEN_CHAR.IND with invalid content, it shall be ignored. Content which deviate from the MME definition in [Table A.4](#) is invalid.
- [V2G3-A09-42] On reception of a CM_START_ATTEN_CHAR.IND message, the EVSE shall start the TT_EVSE_match_MNBC timer.
- [V2G3-A09-43] While the timer TT_EVSE_match_MNBC is running, the EVSE shall receive and process incoming CM_ATTEN_PROFILE.IND messages. If the anticipated number of CM_ATTEN_PROFILE messages is not achieved, the EVSE shall keep listening for incoming CM_ATTEN_PROFILE.IND messages until the timer TT_EVSE_match_MNBC expires.
- [V2G3-A09-44] If all M-Sound messages are received by the EVSE or the TT_EVSE_match_MNBC timer expires, the EVSE shall compute (analyse and average) all received CM_ATTEN_PROFILE messages within the time window given by the TP_EVSE_avg_atten_calc timer. This performance timer shall be started as soon as TT_EVSE_match_MNBC expires.
- [V2G3-A09-45] After having computed all received data, the EVSE shall send a CM_ATTEN_CHAR.IND within TP_EVSE_avg_atten_calc and start the timer TT_match_response.
- [V2G3-A09-46] If the EVSE has not received a CM_ATTEN_CHAR.RSP within TT_match_response, it shall retransmit a CM_ATTEN_CHAR.IND when the TT_match_response expires and reset this timer. After C_EV_match_retry attempts, if no CM_ATTEN_CHAR.RSP is received by the EVSE, the matching process shall be considered as FAILED.
- [V2G3-A09-47] If the EVSE receives a CM_ATTEN_CHAR.RSP with invalid content, it shall be ignored. Content which deviate from the MME definition in [Table A.4](#) is invalid.

A.9.3 Validation of matching decision

A.9.3.1 Functional description

The validation of matching decision is a method to validate the SLAC based matching by means of the control pilot line. In case the EV is not able to come to a distinct matching decision on base of the signal strength measurement, it may decide to do an additional validation process. The validation process is divided in two parts consisting of a CM_VALIDATE.REQ and CM_VALIDATE.CNF each. It is important to consider that the first and second request-response differ in the contents of the messages. In the following messages related to the first/second request-response are designated with “step 1” or “step 2”, respectively.

The validation process is an asynchronous process, which means that an unmatched EVSE answers to a CM_VALIDATE.REQ in any case even with no signal strength measurement immediately before. This behaviour is necessary because the time between the signal strength measurement and the validation for a specific EVSE is not predictable due to an unknown number of validation processes with other EVSEs before.

To request a validation process, the EV sends a first CM_VALIDATE.REQ to the EVSE, which contains a timer value of zero and a result field indicating “ready”. The EVSE responds with a first CM_VALIDATE.

CNF, which contains a ToggleNum of zero. The result field of the message is filled in consistence with the current state of the EVSE:

- When the EVSE is ready to perform the validation process, it fills the result field with “ready”. In this case, the EV will continue with sending the step 2 CM_VALIDATE.REQ.
- When the EVSE is busy and not able to perform a validation, it fills the result field with “not ready”. In this case, the EVSE is not ready for the step 2 CM_VALIDATE.REQ. The EV may start a retry by resending the first CM_VALIDATE.REQ again.
- When the EVSE wants to indicate that a validation is not required, it fills the result field with “not required”. In this case, the EV may follow this advice and stop the validation process or continue the process with sending the step 2 CM_VALIDATE.REQ to force the EVSE to follow the validation process.
- In any special case where the EVSE is not able to perform any validation process or it does not have implemented the validation process feature, it fills the result field with “failure”.

The second part of the validation process covers the control pilot toggle sequence on EV side and the counting of control pilot toggles on the EVSE side. The EV starts this process by sending the step 2 indicating “ready”. With receiving the step 2 CM_VALIDATE.REQ, the EVSE starts counting the BCB-toggles for a time window given by the timer field of the request. As soon as the timer expires, the EVSE sends a step 2 CM_VALIDATE.CNF to the EV containing the number of BCB-Toggles seen and the result field filled with “Success”. The field is filled with “failure” whenever the validation could not be performed or the number of seen BCB-Toggles does not contain valid data.

In the case the validation does not confirm the matching decision of the signal strength measurement, the EV may continue with the next potential EVSE.

The main process is described in [9.4](#).

[V2G3-A09-48] If the EV_Discovering_Status is “EVSE_FOUND”, validation shall only be performed if the EV insists to. Otherwise, the validation process shall be skipped.

[V2G3-A09-49] If the EV decides that “EVSE_POTENTIALLY_FOUND” is equal to “EVSE_FOUND”, then a BCB-Toggle is not mandatory.

[V2G3-A09-50] According to the EVSE Architecture, the EVSE can decide to answer to a CM_VALIDATE.REQ with the result field of CM_VALIDATE.CNF filled to “Not_Required”. In this case, the EV shall decide

- either to continue the validation process, by continuing with the step 2 CM_VALIDATE.REQ, or
- either to skip the validation process by informing the EVSE of the decision, using the CM_SLAC_MATCH.REQ.

[V2G3-A09-51] According to the EVSE Implementation, the EVSE can decide to answer to a CM_VALIDATE.REQ with the result field of CM_VALIDATE.CNF filled to “Failure”, if it does not have implemented the validation process feature. In this case, the EV shall decide

- either to skip the validation process and continue the matching process with SLAC_MATCH.REQ message,
- either to continue the validation process with the next available EVSE, which was “EVSE_POTENTIALLY_FOUND” according to [Figure 10](#), or
- either to terminate the session if there is no other available EVSE with “EVSE_POTENTIALLY_FOUND” status according to [Figure 10](#).

[V2G3-A09-52] Both EV and EVSE shall comply with the sequence diagrams defined in [Figure A.2](#).

[V2G3-A09-53] If the EVSE is not able to perform any BCB-Toggle due to not having implemented this feature, it shall set the result field to “failure”.

A.9.3.2 Description of involved MMEs

[V2G3-A09-54] Both EV and EVSE shall use the CM_VALIDATE messages to exchange the BCB-Toggle related values, using the parameters defined in [9.4](#).

[V2G3-A09-55] The Ethernet Destination MAC address field shall be filled either as Broadcast or Unicast, as defined in the [Table A.5](#) and [Table A.6](#).

Table A.5 — MMEs parameters definition for validation process – First request-response

MME	Field	Octet no.	Field size (Octets)	Value	Definition
CM_VALIDATE.REQ Unicast	Signal Type	0	1	0x00	Fixed value to indicate “PEV S2 toggles on control pilot line”
	Timer	1	1	0x00	Fixed value In the first VALIDATE Request-Response exchange, the Timer field shall be set to zero.
	Result	2	1	0x01	Fixed value In the first VALIDATE Request-Response exchange, the Result field shall be set to 0x01 = “ready”.
CM_VALIDATE.CNF Unicast	SignalType	0	1	0x00	Fixed value to indicate “PEV S2 toggles on control pilot line”
	ToggleNum	1	1	0x00	Fixed value In the first VALIDATE Request-Response exchange, the ToggleNum field shall be set to zero.
	Result	2	1	variable	Result code: 0x00 = Not Ready 0x01 = Ready 0x02 = Success 0x03 = Failure 0x04 = Not Required

[V2G3-A09-56] For the first CM_VALIDATE request-response exchange, the result field shall be filled as follows:

[V2G3-A09-57] The EV shall set the result field of the CM_VALIDATE.REQ with 0x01 to indicate that a validation process starts.

[V2G3-A09-58] The EVSE shall set the Result field of the CM_VALIDATE.CNF to the following:

- “Ready” to confirm the readiness for a validation process;
- “Not Ready” to indicate that it is busy and temporarily not able to perform a validation (An immediate retry with the step 1 CM_VALIDATE.REQ by the EV is reasonable);
- “Success” shall not be used;

- “Not required” to indicate that a validation is not required;
- “Failure” to indicate that it does not support the validation procedure. According to A.7.3.1, the EV can decide on how to continue.

Table A.6 — MMEs parameters definition for validation process – Second request-response

MME	Field	Octet no.	Field size (Octets)	Value	Definition
CM_VALIDATE.REQ Broadcast	Signal Type	0	1	0x00	Fixed value to indicate “PEV S2 toggles on control pilot line”
	Timer	1	1	variable	Variable value indicating the time duration while the EVSE shall listen to BCB-Toggles (TT_EVSE_vald_toggle): 0x00 = 100 ms 0x01 = 200 ms
	Result	2	1	0x01	Fixed value In the second VALIDATE Request-Response exchange, the Result field shall be set to 0x01 = “ready”.
CM_VALIDATE.CNF Unicast	SignalType	0	1	0x00	Fixed value to indicate “PEV S2 toggles on Control Pilot line”
	ToggleNum	1	1	variable	This value contains the number of BC-edges detected by the EVSE during TT_EVSE_vald_toggle
	Result	2	1	variable	Result code: 0x00 = Not Ready 0x01 = Ready 0x02 = Success 0x03 = Failure 0x04 = Not Required

[V2G3-A09-59] For the second CM_VALIDATE request-response exchange, the result field shall be filled as follows:

[V2G3-A09-60] The EV shall set the result field of the CM_VALIDATE.REQ with 0x01 to indicate that a toggle process starts.

[V2G3-A09-61] The EVSE shall set the result field of the CM_VALIDATE.CNF to

- “Success” to confirm that the toggle process is done with success and the result field contains valid data, or
- “Failure” to indicate that the toggle process could not be finished with success and the result field contains no valid data.

A.9.3.3 Timing constraints and error handling

A.9.3.3.1 Sequence chart

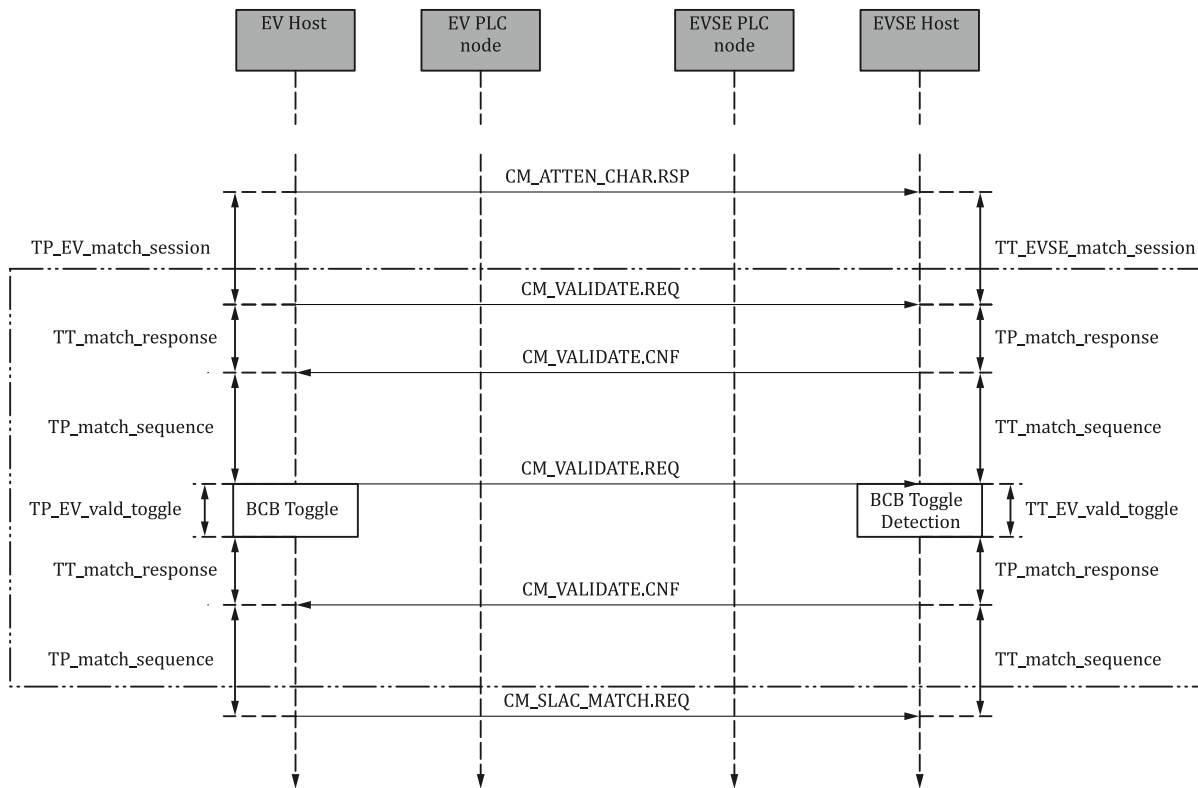

Figure A.5 — Sequence chart of validation process of matching decision

A.9.3.3.2 EV side

- [V2G3-A09-62]** With sending the step 1 **CM_VALIDATE.REQ**, the EV shall start the timer **TT_match_response**. When the **TT_match_response** timer expires, the EV shall resend the step 1 **CM_VALIDATE.REQ** with **C_EV_match_retry** number of retries. The timer shall be restarted with any retry. The **TT_match_response** timer shall stop with the reception of a valid **CM_VALIDATE.CNF**.
- [V2G3-A09-63]** If the EV does not receive any valid **CM_VALIDATE.CNF** for all retries, the EV shall stop the validation process with the current EVSE and continue the validation process with the next potential EVSE.
- [V2G3-A09-64]** If any received **CM_VALIDATE.CNF** contains invalid content, it shall be ignored. Content which deviates from the MME definition in [Table A.5](#) and [Table A.6](#) is invalid.
- [V2G3-A09-65]** If the result field of the step 1 **CM_VALIDATE.CNF** contains “Success”, the EV shall stop the validation process with the current EVSE and continue the validation process with the next potential EVSE.
- [V2G3-A09-66]** If the result field of the step 1 **CM_VALIDATE.CNF** contains “not ready” the EV shall either retry after undefined amount of time or continue the validation with the next potential EVSE with the option to retry the validation with the “not ready” EVSE again afterwards.

If the Result field of the step 1 CM_VALIDATE.CNF contains “not required”, the EV may skip the validation process.

- [V2G3-A09-67]** If the result field of the step 1 CM_VALIDATE.CNF contains “ready”, the EV shall send the step 2 CM_VALIDATE.REQ within TP_match_sequence with a timer value which covers the whole BCB-Toggle sequence.
- [V2G3-A09-68]** With sending the step 2 CM_VALIDATE.REQ, the EV shall start the timer TP_EV_vald_toggle and shall start the BCB-Toggle sequence. The timer TP_EV_vald_toggle shall be equal to the timer value sent within the step 2 CM_VALIDATE.REQ.
- [V2G3-A09-69]** The BCB-Toggle sequence shall be finished before the TP_EV_vald_toggle timer expires.
- [V2G3-A09-70]** When TP_EV_vald_toggle timer expires, the EV shall start the TT_match_response timer. While the TT_match_response timer is running, the EV shall listen for the incoming step 2 CM_VALIDATE.CNF MME. The TT_match_response timer shall stop as soon as a valid CM_VALIDATE.CNF was received.
- [V2G3-A09-71]** If the TT_match_response timer expires, the EV shall stop the validation process with the current EVSE and continue the validation process with the next potential EVSE.
- [V2G3-A09-72]** If the result field of the step 2 CM_VALIDATE.CNF contains “failure”, “not ready”, or “not required”, the EV shall stop the validation process with the current EVSE and continue the validation process with the next potential EVSE.
- [V2G3-A09-73]** If the result field of the step 2 CM_VALIDATE.CNF contains “Success” the EV shall compare the ToggleNum field of the CM_VALIDATE.CNF message with the number of BCB-Toggles executed. If the numbers are equal, the EV_Discovering_Status is confirmed as “EVSE_FOUND” otherwise, the EV shall continue the validation process with the next potential EVSE.
- [V2G3-A09-74]** If the matching status is confirmed by the validation, the EV shall continue with the CM_SLAC_MATCH.REQ within TP_match_sequence after receiving the step 2 CM_VALIDATE.CNF.

A.9.3.3.3 EVSE side

- [V2G3-A09-75]** With receiving a step 1 CM_VALIDATE.REQ from the EV which started the matching process and with a timer field equal to “0x00”, the EVSE shall respond with a CM_VALIDATE.CNF within TP_match_response.
- [V2G3-A09-76]** If any received CM_VALIDATE.REQ contains invalid content, it shall be ignored. Content which deviate from the MME definition in [Table A.5](#) and [Table A.6](#) is invalid.
- [V2G3-A09-77]** If the EVSE receives another CM_VALIDATE.REQ with a timer field equal to zero after sending out the step 1 CM_VALIDATE.CNF, the step 1 CM_VALIDATE.CNF shall be resent.
- [V2G3-A09-78]** If the EVSE is occupied by another running validation process, it shall set the result field to “not ready”.
- [V2G3-A09-79]** If the EVSE is able to perform the validation process and is not occupied, it shall continue the validation process, setting the result field to “ready” or “not required”.

- [V2G3-A09-80] If the EVSE is not able to perform the validation process, it shall set the result field to “failure”.
- [V2G3-A09-81] If the EVSE has sent the step 1 CM_VALIDATE.CNF with result field set to “not required”, it shall be prepared that the EV will continue the process with the step 2 CM_VALIDATE.REQ or a CM_SLAC_MATCH.REQ message.
- [V2G3-A09-82] With sending the step 1 CM_VALIDATE.CNF, the EVSE shall start the timer TT_match_sequence. When the TT_match_sequence timer expires, the EVSE shall re-send the step 1 CM_VALIDATE.CNF with C_EV_match_retry number of retries. The timer shall be restarted with any retry. The TT_match_sequence timer shall stop with the reception of a valid step 2 CM_VALIDATE.REQ or with a valid CM_SLAC_MATCH.REQ.
- [V2G3-A09-83] If the EVSE does not receive any valid step 2 CM_VALIDATE.REQ or valid CM_SLAC_MATCH.REQ for all retries, the matching process shall be considered as FAILED.
- [V2G3-A09-84] If any CM_VALIDATE.REQ contains a result field other than “ready”, the matching process shall be considered as FAILED.
- [V2G3-A09-85] With receiving a step 2 CM_VALIDATE.REQ from the EV which started the matching process, the EVSE shall start the timer TT_EVSE_vald_toggle.
- [V2G3-A09-86] While the timer TT_EVSE_vald_toggle is running, the EVSE shall count the BCB-Toggles on the control pilot.
- [V2G3-A09-87] After the timer TT_EVSE_vald_toggle is expired, the EVSE shall send a step 2 CM_VALIDATE.CNF with the number of counted BCB-Toggles and the result field set to “Success” within TP_match_response.
- [V2G3-A09-88] In case an error occurs on EVSE side while counting the BCB-Toggles so that the ToggleNum field does not contain valid data, the result field shall be set to “failure”.
- [V2G3-A09-89] With sending the step 2 CM_VALIDATE.CNF, the EVSE shall start the timer TT_match_sequence. The timer shall stop as soon as a CM_SLAC_MATCH.REQ message is received.
- [V2G3-A09-90] When the timer TT_match_sequence expires, the matching process shall be considered as FAILED.

A.9.4 Logical network parameter exchange

A.9.4.1 Functional description

After the EV has finished the matching decision, it requests the parameter for the logical network from the selected EVSE by means of the message CM_SLAC_MATCH.REQ. The selected EVSE responds to the EV request with a CM_SLAC_MATCH.CNF, which contains all parameters to be set to join the logical network of the EVSE.

- [V2G3-A09-91] In order to create the logical network, both EV and EVSE shall use the CM_SLAC_MATCH MMEs defined in the [HPGP] messages, using sequences defined in [Figure A.1](#).
- [V2G3-A09-92] At any time an EVSE switches to a private logical network, the local NMK shall be set per random value to ensure a unique logical network. The configuration of the NMK on EVSE side shall be done with sending a CM_SLAC_MATCH.CNF MME or at anytime before.

It is recommended to set the local NMK on EVSE side before the matching process begins, e.g. at the transition from “matched” to “unmatched” state.

[V2G3-A09-93] The NID of the logical network shall be derived from the NMK according to [HPGP], 4.4.3.1 using a security level value of 0b00.

A.9.4.2 Description of involved MMEs

Table A.7 — MMEs parameters definition for logical network parameter exchange

MME	Field	Octet no.	Field size (Octets)	Value	Definition
CM_SLAC_MATCH. REQ Unicast	APPLICATION_TYPE	0	1	0x00	Fixed value indicating “PEV-EVSE matching”
	SECURITY_TYPE	1	1	0x00	Fixed value indicating “No Security”
	MVFLength	2 to 3	2	0x3e	Fixed value for matching
	PEV ID	4 to 21	17	0x00	-
	PEV MAC	21 to 26	6	MAC address of the EV Host	MAC address of EV Host
	EVSE ID	26 to 43	17	0x00	-
	EVSE MAC	44 to 49	6	MAC address of the EVSE Host	EVSE MAC address
	RunID	50 to 57	8	variable	This value shall be the same as the one sent in the CM_SLAC_PARM.REQ message by the EV.
	RSVD	58 to 65	8	0x00	reserved

Table A.7 (continued)

MME	Field	Octet no.	Field size (Octets)	Value	Definition
CM_SLAC_MATCH.CNF Unicast	APPLICATION_TYPE	0	1	0x00	Fixed value indicating “PEV-EVSE matching”
	SECURITY_TYPE	1	1	0x00	Fixed value indicating “No Security”
	MVFLength	2 to 3	2	0x56	Fixed value for matching
	PEV ID	4 to 20	17	0x00	-
	PEV MAC	21 to 26	6	MAC address of the EV Host	PEV MAC address
	EVSE ID	27 to 43	17	0x00	-
	EVSE MAC	44-49	6	MAC address of the EVSE Host	EVSE MAC address
	RunID	50 to 57	8	variable	This value shall be the same as the one sent in the CM_SLAC_PARM.REQ message by the EV.
	RSVD	58 to 65	8	0x00	reserved
	NID	66 to 72	7	variable	Network ID derived from the NMK by the EVSE according to [HPGP], 4.4.3.1
	RSVD	73	1	0x00	reserved
	NMK	74 to 89	16	variable	Private NMK of the EVSE (random value)

A.9.4.3 Timing constraints and error handling

A.9.4.3.1 Sequence chart

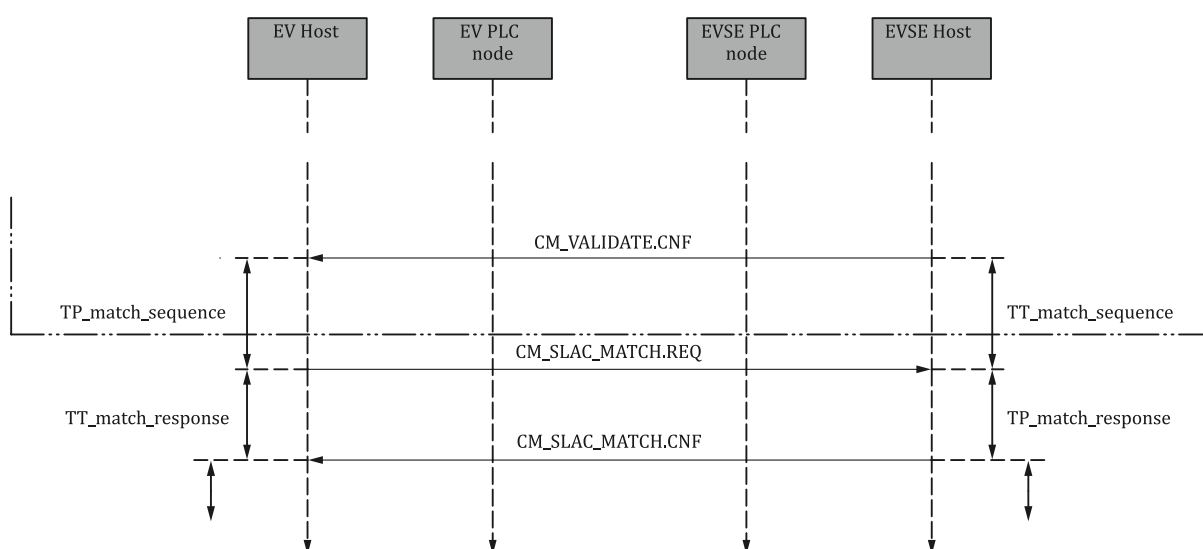

Figure A.6 — Sequence chart of logical network parameter exchange

A.9.4.3.2 EV side

- [V2G3-A09-94]** If the EV has sent a CM_SLAC_MATCH.REQ to the EVSE but does not receive a valid CM_SLAC_MATCH.CNF within the max(TT_match_response), it shall retransmit the CM_SLAC_MATCH.REQ. The timer shall be restarted with any retry. A maximum of C_EV_match_retry retransmissions shall be performed. If after these retransmissions the EV has not received valid response within max (TT_match_response), the matching process shall be considered as FAILED.
- [V2G3-A09-95]** If the EV receives a CM_SLAC_MATCH.CNF with invalid content, it shall be ignored. Content which deviate from the MME definition in [Table A.7](#) is invalid.

A.9.4.3.3 EVSE side

- [V2G3-A09-96]** According to the decision of the EV, if the EVSE does not receive either CM_SLAC_MATCH.REQ or a CM_VALIDATE.REQ within the maximum value of TT_EVSE_match_session, the EVSE shall consider that it is not connected to the EV and shall consider the matching process as FAILED.
- [V2G3-A09-97]** If the EVSE receives another CM_SLAC_MATCH.REQ from the same EV, this means that the EV retransmitted its request for some reason (i.e. the CM_SLAC_MATCH.CNF was not received). The EVSE shall respond to the request again.
- [V2G3-A09-98]** If the EVSE receives a CM_SLAC_MATCH.REQ with invalid content, it shall be ignored. Content which deviate from the MME definition in [Table A.7](#) is invalid.
- [V2G3-A09-99]** After receiving a CM_SLAC_MATCH.REQ, the EVSE shall answer by a CM_SLAC_MATCH.CNF within TP_match_response.

A.9.5 Joining the logical network

A.9.5.1 Functional description

After the right matching between EV and EVSE is determined and the network parameters are exchanged, the EV joins the logical network of the EVSE. Through the broadcast domain is reduced to the low-layer communication module directly connected.

The configuration of the low-layer communication module with the parameters of the logical network may be done with the MMEs CM_SET_KEY.REQ and CM_SET_KEY.CNF.

On EVSE side, there is no constraint that the network parameters have to be configured after the CM_SLAC_MATCH.CNF. This can also be done any time before.

- [V2G3-A09-100]** The low-layer communication module shall join the logical network only if the EV_Discovering_status is EVSE_FOUND.

A.9.5.2 Description of involved MMEs

Table A.8 — MMEs parameters definition for joining the logical network

MME	Field	Octet no.	Field size (octets)	Value	Definition
CM_SET_KEY.REQ Unicast to local low-layer communication node	Key Type	0	1	0x01	Fixed value to indicate "NMK"
	My Nonce	1 to 4	4	0x00000000	Fixed value, encrypted payload not used
	Your Nonce	5 to 8	4	0x00000000	Fixed value, encrypted payload not used
	PID	9	1	0x04	Fixed value to indicate "HLE protocol"
	PRN	10 to 11	2	0x0000	Fixed value, encrypted payload not used
	PMN	12	1	0x00	Fixed value, encrypted payload not used
	CCo Capability	13	1	variable	CCo Capability according to the station role
	NID	14 to 20	7	variable	54 LSBs contain the NID 2 MSBs = 0b00
	NewEKS	21	1	0x01	Fixed value to indicate "NMK"
	NewKey	22 to 37	16	variable	NMK

A.9.5.3 Timing constraints and error handling

A.9.5.3.1 Sequence chart

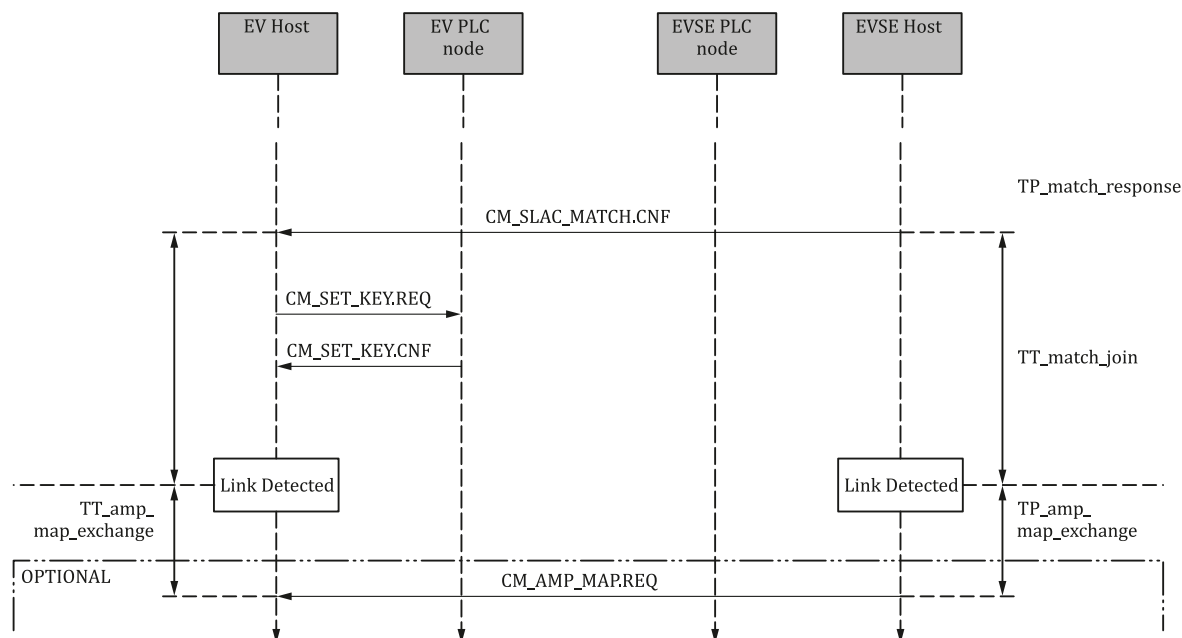

Figure A.7 — Sequence chart of joining the logical network

A.9.5.3.2 EV side

[V2G3-A09-101] After receiving a CM_SLAC_MATCH.CNF from the EVSE, the EV shall configure its low-layer communication module to the values from this message by using the CM_SET_KEY.REQ MME.

NOTE 1 In a specific implementation, methods other than the CM_SET_KEY MMEs may also be used as long as the configuration result is equivalent.

NOTE 2 It is up to the implementation how to handle a negative response in a CM_SET_KEY.CNF or a missing CM_SET_KEY.CNF at all.

[V2G3-A09-102] If no link is established within the max(TT_match_join) after receiving CM_SLAC_MATCH.CNF, the EV shall consider that the matching process is FAILED.

A.9.5.3.3 EVSE side

[V2G3-A09-103] After sending a CM_SLAC_MATCH.CNF containing a NMK and a NID, the EVSE shall start its TT_match_join timer. This timer ends when the CCo detects a link in its logical network.

[V2G3-A09-104] If no link is detected when the TT_match_join timer expires, the EVSE shall consider the matching process as FAILED.

[V2G3-A09-105] The EVSE shall configure its low-layer communication module to the NID and NMK values sent in CM_SLAC_MATCH.CNF at the latest after sending the CM_SLAC_MATCH.CNF. The configuration can also be done at any time before (e.g. after unplugging of a previous EV). The configuration shall be done by sending a CM_SET_KEY.REQ.

NOTE 3 If the EVSE needs to configure its NMK and NID after the CM_SLAC_MATCH.CNF, it should consider that the just sent CM_SLAC_MATCH.CNF might get lost and the EV will send a CM_SLAC_MATCH.REQ retry within TT_match_response. Within this time, the EVSE should not be blind due to the configuration process for the incoming CM_SLAC_MATCH.REQ retry.

A.9.6 Amplitude map exchange

A.9.6.1 Functional description

The amplitude map exchange is an optional function to request the counterpart low-layer communication module to reduce the transmission power for certain carriers. The requesting device sends a CM_AMP_MAP.REQ command which has to be confirmed by the counterpart node by a CM_AMP_MAP.CNF message.

The transmission power limitation request is related to the PSD at EVs/EVSEs socket.

The CM_AMP_MAP.REQ MME has the following two different functions, depending on the source/destination of the message:

- CM_AMP_MAP.REQ sent from one host to another host through the low-layer communication is designated to transmit the requested transmission power per carrier to the destination host to be included in its amplitude map calculation. This message does not have any direct influence on the low-layer communication module transmission power, it is only used for information exchange.
- CM_AMP_MAP.REQ sent from one host to the local low-layer communication module causes the low-layer communication module to modify its transmission power.

All transmission power values within the CM_AMP_MAP MMEs are related to a reference value of -50 dBm/Hz. The resolution of AMDATA are -2 dB, so that a AMDATA value of 0b0011 means a value -6 dB.

Example for request of a transmission power limitation

(For simplification, within this example the total number of carriers is fictitious set to 6)

Assumption:

EVSE requests a limitation of the power of carriers 2 and 3 to -78 dBm/Hz, while the other carriers keep unaffected. The EV has no limitation request to the EVSE.

- The EVSE sends a CM_AMP_MAP.REQ to the EV Host MAC address with the following values: {0,14,14,0,0,0}

AMDATA[0] = 0x0

AMDATA[1] = 0xE

AMDATA[2] = 0xE

Related to the reference of -50 dBm/Hz, the requested value of -78 dBm/Hz leads to the difference of -28 dB which in turn leads to a raw value of 14 (0xE) for 2 dB resolution. Each element of AMDATA has a size of 4 Bit.

- The EV Host compares the received values with its default PSD at the socket, which are assumed to be $\{-75, -75, -77, -77, -75, -75\}$ dBm/Hz. For carriers 2 and 3, the requested values are less than the default ones:

Carrier 1: -75 dBm/Hz $<$ -50 dBm/Hz: ok

Carrier 2: -75 dBm/Hz $<$ -78 dBm/Hz: n.ok. deviation: 3 dBm/Hz

Carrier 3: -77 dBm/Hz $<$ -78 dBm/Hz: n.ok. deviation: 1 dBm/Hz

Carrier 4: -77 dBm/Hz $<$ -50 dBm/Hz: ok

Carrier 5: -75 dBm/Hz $<$ -50 dBm/Hz: ok

Carrier 6: -75 dBm/Hz $<$ -50 dBm/Hz: ok

The carriers 2 and 3 have to be reduced in power by 3 dBm/Hz and 1 dBm/Hz respectively.

- The EV Host confirms the CM_AMP_MAP.REQ with a corresponding CM_AMP_MAP.CNF.
- Based on the calculated attenuation values for the carriers 2 and 3, the EV Host subtract these from the default low-layer communication module setting and writes them to the low-layer communication module using the CM_AMP_MAP.REQ and its local destination address.

[V2G3-A09-106] In the case that a low-layer communication module requires additional carriers to be notched, it shall send the amplitude map to the remote low-layer communication module as soon as the logical network is set up. Therefore, the sequence described in [Figure A.2](#) and A.7.6.2 for detailed primitives shall be used. The amplitude map for further communication shall be the intersection of the low-layer communication module's local amplitude and the received amplitude map from the remote low-layer communication module.

[V2G3-A09-107] As long no exchange of an amplitude map is trigger by one of the low-layer communication modules, a default amplitude map shall be used.

NOTE The EVSE should guarantee the conformity to local legislation on authorized/forbidden frequencies in the frequency band 2 MHz to 30 MHz. By this mechanism, the EV will always comply with the local legislation. The EVSE should be able to be reconfigured to future evolution of restrictions.

A.9.6.2 Description of involved MMEs

- [V2G3-A09-108]** The Ethernet destination MAC address field shall be filled as Unicast, as defined in the [Table A.9](#).
- [V2G3-A09-109]** To exchange an amplitude map, the CM_AMP_MAP.REQ message defined in [HPGP] shall be used. The content is shown in [Table A.9](#).
- [V2G3-A09-110]** To confirm an amplitude map exchange, the CM_AMP_MAP.CNF message defined in [HPGP] shall be used. The content is shown in [Table A.9](#).

An amplitude map exchange can be initiated by an EV or an EVSE by sending a “CM_AMP_MAP.REQ” message.

Table A.9 — MMEs parameters definition for amplitude map exchange

MME	Field	Octet no.	Field size	Value	Definition
CM_AMP_MAP.REQ Unicast	AMLEN	0 to 1	2 Octet	0x3A	Fixed value to indicate the number of carriers used
	AMDATA[0]	2	4 Bit	variable	Amplitude Map Data: 4 LSBs First unmasked carrier
	AMDATA[1]	2	4 Bit	variable	Amplitude Map Data: 4 MSBs Second unmask carrier
	AMDATA[n]	-	4 Bit	variable	
CM_AMP_MAP.CNF Unicast	ResType	0	1 Octet	variable	Result code: 0x00 = success 0x01 = failure 0x02 – 0xFF = reserved

A.9.6.3 Timing constraints and error handling

A.9.6.3.1 Sequence chart

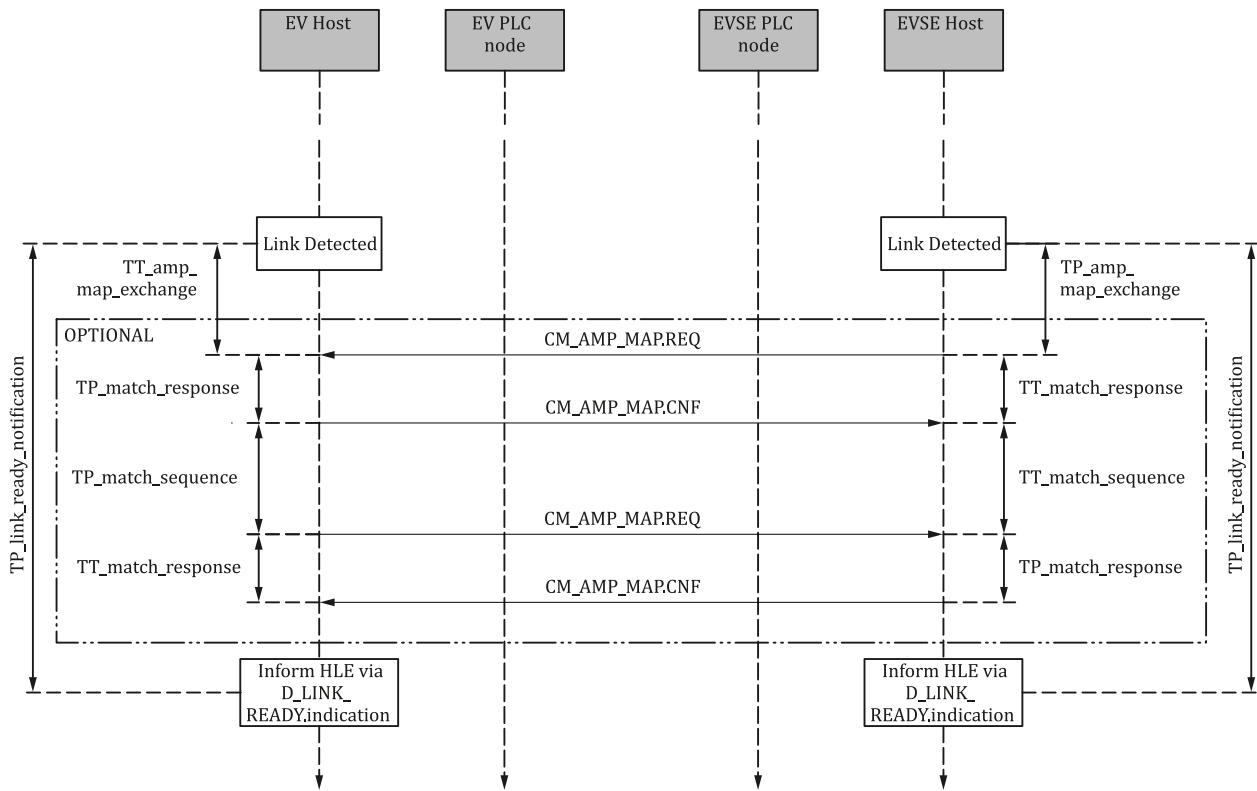

Figure A.8 — Sequence chart of amplitude map exchange

A.9.6.3.2 EV and EVSE sides

- [V2G3-A09-111] If a low-layer communication module needs to request an amplitude map exchange from the counterpart device, the CM_AMP_MAP.REQ shall be sent within TP_amp_map_exchange. The timer TP_amp_map_exchange shall be started with the detection of other stations in the current logical network after the SLAC_MATCH exchange.
- [V2G3-A09-112] If a low-layer communication module has sent a CM_AMP_MAP.REQ but does not receive a valid CM_AMP_MAP.CNF within the max(TT_match_response), it shall retransmit the CM_AMP_MAP.REQ. The timer shall be restarted with any retry. A maximum of C_EV_match_retry retransmissions shall be performed. If after these retransmissions the low-layer communication module has not received valid response within max(TT_match_response), the matching process shall be considered as FAILED.
- [V2G3-A09-113] If a low-layer communication module receives a CM_AMP_MAP.REQ with invalid content, it shall be ignored. Content which deviate from the MME definition in [Table A.9](#) is invalid.
- [V2G3-A09-114] If a low-layer communication module receives a CM_AMP_MAP.CNF with invalid content, it shall be ignored. Content which deviate from the MME definition in [Table A.9](#) is invalid.

- [V2G3-A09-115]** After receiving a CM_AMP_MAP.REQ within TT_amp_map_exchange, a low-layer communication module shall answer with a CM_AMP_MAP.CNF within TP_match_response. The timer TT_amp_map_exchange shall be started with the detection of other stations in the current logical network.
- [V2G3-A09-116]** If the requested node receives another CM_AMP_MAP.REQ, this means that the counterpart station retransmitted its request for some reason (i.e. the CM_AMP_MAP.CNF was not received); the requested node shall respond to the request again.
- [V2G3-A09-117]** If the timer TT_amp_map_exchange expires without receiving a CM_AMP_MAP.REQ from the counterpart low-layer communication module and without sending a CM_AMP_MAP.REQ, the D-LINK_READY.indication (link established) shall be sent to higher layers.
- [V2G3-A09-118]** As soon as the state “Matched” is reached, no further SLAC messages shall be sent or processed.
- [V2G3-A09-119]** If an amplitude map exchange is initiated by one of the low-layer communication modules in the logical network, the higher layer shall not be informed about the valid data link before the link is re-established after the amplitude map exchange and the local configuration of the modified amplitude map is done.
- [V2G3-A09-120]** The time between the detection of other stations in the current logical network after the SLAC_MATCH exchange and the indication D-LINK_READY.indication (link established) to higher layers shall not exceed the performance timer TP_link_ready_notification.

A.9.7 Leave the logical network

This subclause describes a method to allow higher layer to terminate the link. Without the request from higher layers to terminate the link, the CCo of the logical network may need several seconds to discover that the EV has left the network.

- [V2G3-A09-121]** With receiving a D-LINK_TERMINATE.request from HLE, the low-layer communication module shall leave the logical network, reset the NMK, and switch to matching state “Unmatched”. The low-layer communication module shall follow the Clause “Leaving an AVLN” defined in the [HPGP].

A.9.8 General error handling and timing constraints

- [V2G3-A09-122]** A timer TT_matching_repetition shall be started with the trigger of the matching process defined in Requirements [V2G3-M06-11] and [V2G3-M06-13].
- [V2G3-A09-123]** In any case the matching process is considered as FAILED, the matching process shall be restarted as long as the timer TT_matching_repetition is not expired and a control pilot is detected in state Bx, Cx, or Dx.
- [V2G3-A09-124]** In any case the matching process is considered as FAILED, wait for a time of TT_matching_rate before restarting the process.
- [V2G3-A09-125]** If the matching process fails for all retries started within TT_matching_repetition, the matching process shall be stopped in “Unmatched” state (see [Figure 11](#)).
- [V2G3-A09-126]** In any case a plug out is detected during the matching process, the matching process shall be stopped in “Unmatched” state (see [Figure 11](#)).

[V2G3-A09-127] In any case a control pilot state E or state F is detected during the matching process, the matching process shall be stopped in “Unmatched” state (see [Figure 11](#)).

A.9.8.1 Example of matching process error handling

[Figure A.9](#) gives an example of matching process error handling. The low-layer communication module of the EV is awake and the low-layer communication module of the EVSE is asleep. The EVCC sends first CM_SLAC_PARM.REQ message immediately after cable plug-in. The EVSE has to boot its low-layer communication module and is not able to answer the CM_SLAC_PARM.REQ message. After the low-layer communication module on the EVSE side is ready for communication, it sends a CM_SLAC_PARM.CNF.

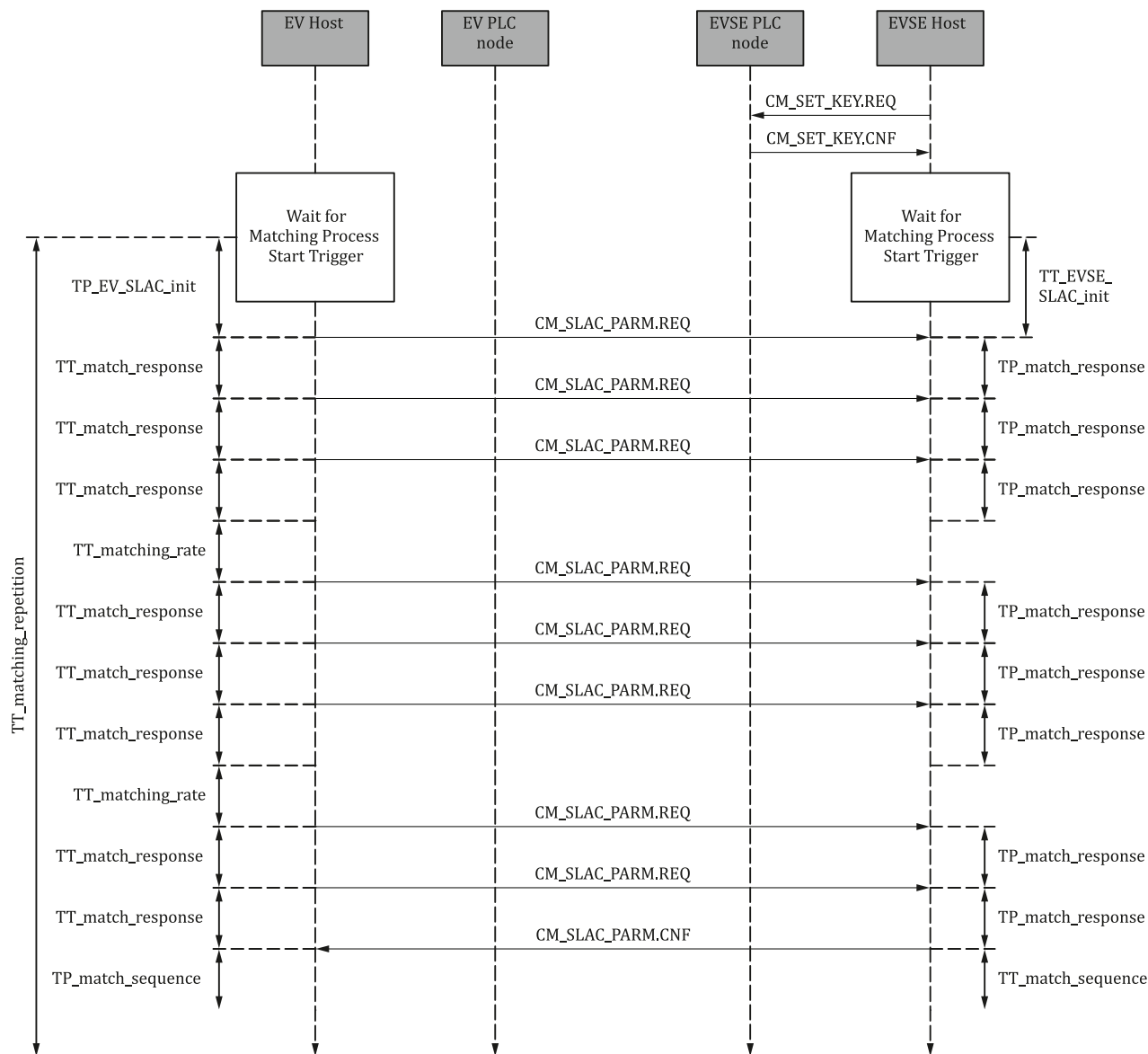

Figure A.9 — Example of sequence chart of matching process error handling

A.10 EMC requirements

[V2G3-A10-01] All low-layer communication modules shall notch out the carriers listed in [Table A.10](#) in the tone mask.

Table A.10 — Notched carriers

HomePlug GeenPHY carrier
0 to 85
140 to 167
215 to 225
283 to 302
410 to 419
570 to 591
737 to 748
857 to 882
1 016 to 1 027
1 144 to 1 535

A.11 Signal coupling

A.11.1 Overview

This Clause defines the requirements that have to be fulfilled in order to inject HomePlug Green PHY signals into the control pilot line to enable bidirectional HomePlug Green PHY communication between one EVSE and one EV.

The HomePlug Green PHY signals on the control pilot line are compliant with [HPGP] except the signal coupling, signal levels, and carrier usage.

As HomePlug Green PHY signal's coupling is directly linked to the control pilot, the schematic in [IEC-1], Annex A specification is basis for definitions regarding the control pilot signal.

To enable HomePlug Green PHY injection, the path from EVSE's output to EV's input should not be considered as capacitive only as it is sufficient for the low frequency control pilot signal. For high frequency HomePlug Green PHY, the path should be considered as a transmission line. To take the high frequency into account, the control pilot circuit and the component values have to be specified in more detail.

For the control pilot line, the additional capacity of the HomePlug Green PHY coupling circuit has to be considered. For the HomePlug Green PHY signal, the partitioning of the capacitive load of the EV, EVSE, and the charge cord is important and is detailed in this Clause.

A.11.2 General drawing for HomePlug Green PHY injection

[V2G3-A11-01] All technical requirements described in this Clause are assumed to have a dedicated pair of HomePlug Green PHY chips implemented for the couple (EVSE, EV), linked by a control pilot wire. [Figure A.10](#) depicts an implementation of parallel injection and gives definitions used further.

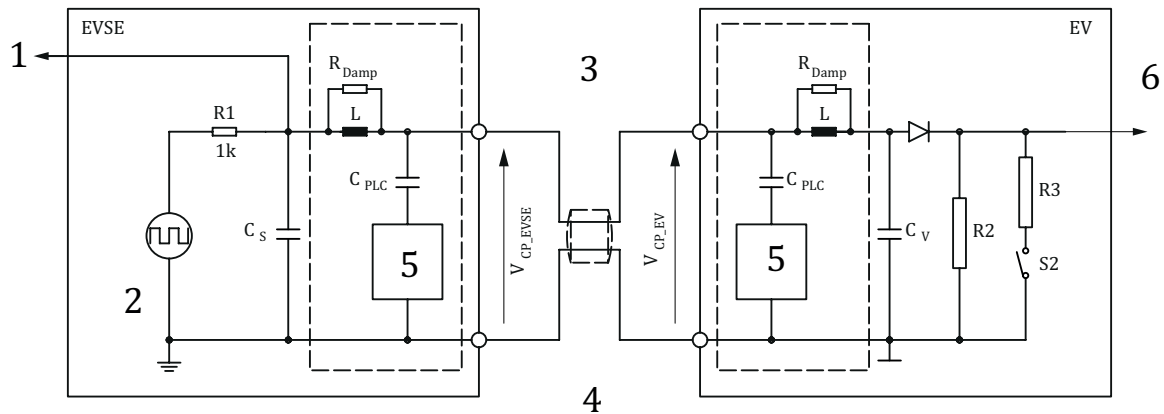

Key

- 1 voltage measurement
- 2 oscillator ± 12 V, 1 kHz
- 3 pilot contact
- 4 earth (ground)
- 5 Green PHY modem
- 6 duty cycle and frequency measurement
- additional components for PLC coupling

Figure A.10 — Implementation of parallel injection

NOTE 1 Different topologies like point-to-multipoint are not covered and might require adaptations.

NOTE 2 The coupling drawing is valid for cases A, B, and C, as defined in the [IEC-1].

NOTE 3 The coupling capacitors are equivalent components, which can be implemented with more than one component. For example, two capacitors, as soon as the requirements about values given in the table below is fulfilled.

NOTE 4 L and R_{Damp} associated with capacitors form low pass filters, which ensure the basic signalling and HomePlug Green PHY communication at the same time. Through the filters, low frequency signals can pass to the control pilot line and high frequency signals are available at the Green PHY modem. The R_{Damp} resistors limit resonance effects of the RLC filters.

- [V2G3-A11-02]** In case of parallel injection, the HomePlug Green PHY signal shall be coupled between the control pilot wire and the PE (Protective Earth) wire.
- [V2G3-A11-03]** In case of parallel injection, the HomePlug Green PHY injection circuit on EVSE side shall be wired to the control pilot and the PE. Additional components, such as EMC or ESD protection, should not affect the HomePlug Green PHY signals.
- [V2G3-A11-04]** In case of parallel injection, the HomePlug Green PHY injection circuit on EV side shall be wired to the control pilot line and the ground. Additional components, such as EMC or ESD protection, should not affect the HomePlug Green PHY signals.
- [V2G3-A11-05]** HomePlug Green PHY shall work with any valid control pilot duty cycle or state as defined in [IEC-1].

[V2G3-A11-06] A proper voltage level and duty cycle of the control pilot raw signal shall be implemented on EVSE side, to ensure [IEC-1] compliancy in presence of an additional HomePlug Green PHY signal.

The [ISO-3] highly recommends to apply at least a first order low pass filter with a cut-off frequency of 100 kHz to 200 kHz for measurements on the control pilot signal (e.g. duty cycle or amplitude), not to disturb the measurement by high frequency HomePlug Green PHY signals.

A.11.3 Signal requirements for HomePlug Green PHY injection

[Table A.11](#) gives requirements that physical signals shall comply with, in order to enable HomePlug Green PHY injection into the control pilot line, according to previous requirements.

NOTE The HomePlug Green PHY signal has to be added to control pilot signal on the control pilot line. The resulting signal should be the algebraic sum of PWM control pilot signal and of the HomePlug Green PHY signals.

[V2G3-A11-07] The control pilot line and the PE wires shall be considered as a transmission line for the HomePlug Green PHY signal; as defined in [Table A.11](#).

Table A.11 — Definition of electrical characteristics

Parameter	Conditions and comments	Min	Typ	Max	Unit	Note
Length of the cable assembly				10	m	
C_{PLC}	See definition above	-	1,35		nF	3,4
R_{Damp}	See definition above	-	220	1 k	Ω	3,4
L	See definition above	-	220		μ H	3,4
C_S	See definition in [IEC-1]				pF	1,3,4
C_V	See definition in [IEC-1]				pF	1,3,4
Power Spectral Density of HomePlug Green PHY signals at V_{CP_EVSE} and V_{CP_EV} Measurement method defined in A.9.4.2	From 1,8 MHz to 30 MHz, RBW = 9 kHz on 50 Ω . Non-notched carriers		-75	-73	dBm/ Hz	
Peak-Peak Voltage of HomePlug Green PHY signals at V_{CP_EVSE} and V_{CP_EV}	Control pilot signal steady at high or low level – 1 low-layer communication actually emitting at a time (peak to peak) – EV connected to the EVSE with the cable assembly. Measured at max PSD level with example of injection circuit given below	-	1,3		Vpp	2,3
Conducted crosstalk from control pilot line to the mains (through power supply) (measured between any live or neutral wire and PE/CP)	From 2 MHz to 28 MHz			-40	dB	

NOTE 1 Any capacity on the control pilot line which is directly connected between the control pilot line and ground should be as small as possible, not to attenuate the HomePlug Green PHY signal in an excessive way. Most of the capacitive load should be separated from the high frequency HomePlug Green PHY with the inductor L .

NOTE 2 At given impedance, the maximum peak to peak amplitude is directly linked to the PSD, also defined in [Table A.11](#). For the purpose of limiting the impact of the high frequency signal on the control pilot line, a simplification from definition in frequency domain to a peak-to-peak voltage is sufficient.

NOTE 3 The maximum values are defined by [IEC-1], Annex A.

NOTE 4 These parameters are to be considered with parallel injection only, as defined in [Figure A.10](#).

A.11.4 Signal transmission path and signal measurement

This subclause defines a typical transmission path for the HomePlug Green PHY signal. This includes PSDs, attenuations, and measurement procedures. Especially the SLAC method for measuring the signal strength needs a well-defined power level for signal transmission.

A.11.4.1 Typical transmission path

[Figure A.11](#) shows the transmission path for the PLC signal with example values for attenuations and PSDs. All PSD and attenuation values are intended as a list of values over carrier groups, single values in the following description are given for simplification only. The following are attenuations that are assumed as example values

- AttnRxEV is the insertion loss of the receiving path between the HomePlug Green PHY Modem and the charge coupler on EV side. In the example, a value of 5 dB is assumed (e.g. through to transformers, lines, coupling components).
- AttnTxEV is the insertion loss of the transmitting path between the HomePlug Green PHY Modem and the charge coupler on EV side. In the example, a value of 4 dB is assumed (e.g. through to transformers, lines, coupling components).
- AttnRxEVSE is the insertion loss of the receiving path between the HomePlug Green PHY Modem and the charge coupler on EVSE side. In the example, a value of 3 dB is assumed (e.g. through to transformers, lines, coupling components).
- AttnTxEVSE is the insertion loss of the transmitting path between the HomePlug Green PHY Modem and the charge coupler on EVSE side. In the example, a value of 5 dB is assumed (e.g. through to transformers, lines, coupling components).
- AttnCord is the insertion loss of the charge cord itself.

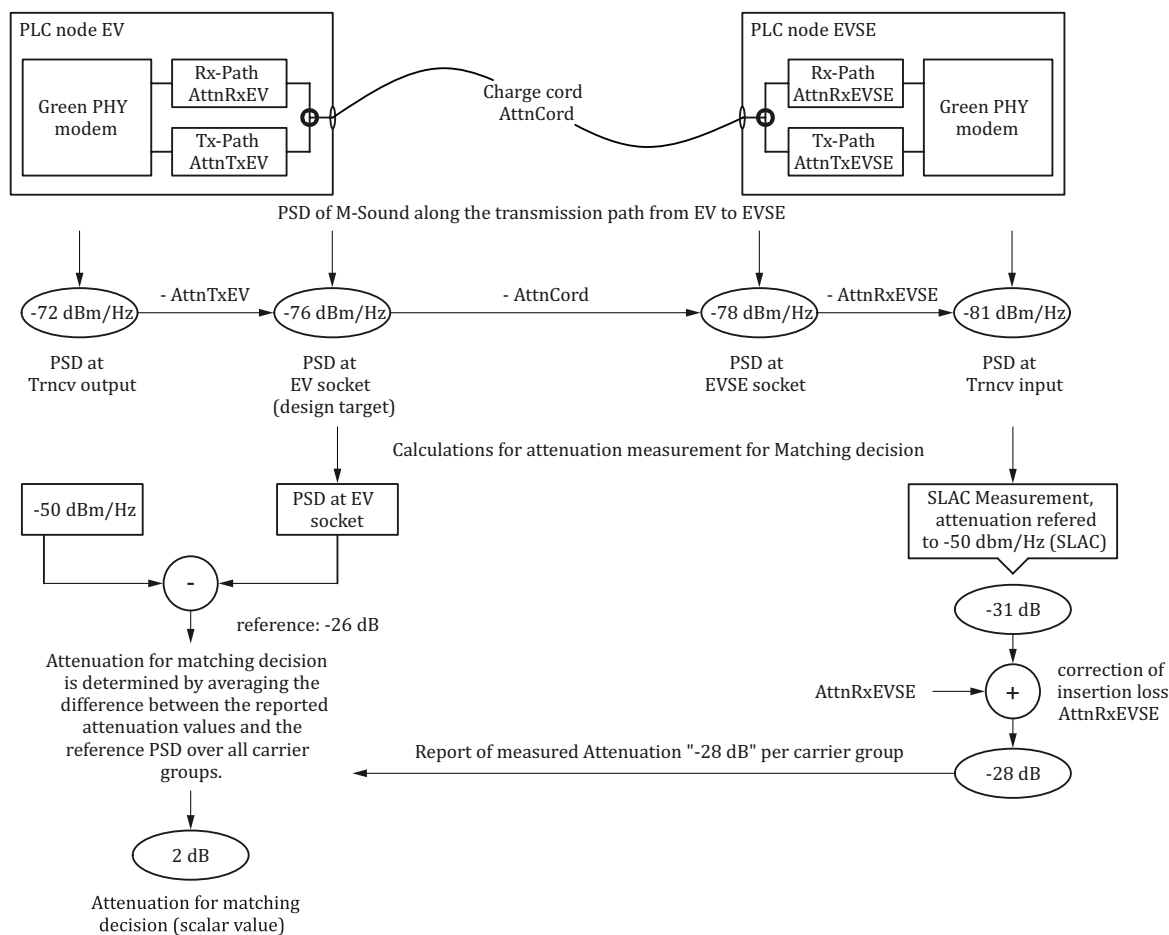

NOTE All PSD and attenuation values are intended as a list of values over carrier groups. In this figure, single values are given for simplification only.

Figure A.11 — HomePlug Green PHY-Transmission path example with SLAC relevant attenuations and calculations

In the example, the design target is to achieve a PSD at the inlet of device of -76 dBm/Hz over the spectrum. Due to insertion losses in the transmission path (AttnTxEV), the output power of the modem (-72 dBm/Hz) has to be higher to compensate the attenuation AttnTxEV. The way of measuring the PSD for the transmission path is given in [A.9.4.2](#).

The charge cord attenuates the HomePlug Green PHY signal by AttnCord, which leads in the example to a PSD at the counterpart socket-outlet of -78 dBm/Hz . Within the EVSE, the signal is also affected by an insertion loss (AttnRxEVSE) of the Rx path from the socket-outlet to the Green PHY modem.

Calibration and correction

Rx-Path on EVSE side:

The low-layer communication module on EV side does not know the value of AttnRxEVSE. Since this value has an impact on the SLAC measurement, the EVSE has to correct the measurement values by AttnRxEVSE before reporting the values back to the EV.

Tx-Path:

Any low-layer communication module has to comply with the transmission power given by the PSD range in [Table A.11](#). The measurement procedure to be used is given in [A.9.4.2](#).

Beside the requirement for all low-layer communication modules to comply with the defined PSD values on EV side, the exact knowledge of the PSD at the inlet is required as a reference for reported attenuation profiles from EVSEs. Any received attenuation profile from an EVSE has to be compared against the reference value given by the Tx-PSD at the inlet minus the -50 dBm/Hz reference defined for the SLAC measurement.

A.11.4.2 Conditions of measurement

In the [Figure A.12](#), a measurement setup and procedure is defined to determine the electrical characteristic of the transmitted signal of a V2G-device in frequency domain by means of a power spectrum density (PSD). The numeric values for the PSD is defined in [Table A.11](#) and ensures a comparable signal characteristic within a certain tolerance range across V2G devices.

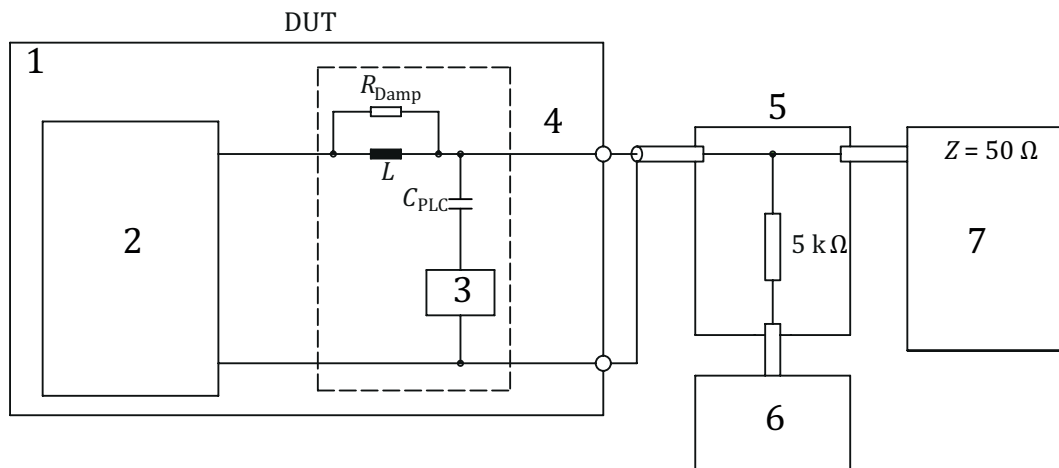

Key

- 1 PLC node
- 2 EV or EVSE control pilot circuit according to IEC 61851-1:2010, Annex A
- 3 data modem
- 4 control pilot
- 5 splitter
- 6 PLC counterpart station
- 7 spectrum analyser

 additional components for PLC coupling

 50 Ohm coax cable

Figure A.12 — Measurement setup

The process defined in this Clause assumes a 50Ω load between the control pilot terminal and the ground/earth conductor. All output voltages are specified as the voltage measured at the control pilot and ground/earth terminals of the socket outlet/vehicle inlet.

[V2G3-A11-08] Measurements shall be made by using equipment conforming to CISPR 16 specifications with a resolution bandwidth of 9 kHz.

[V2G3-A11-09] A low-layer communication counterpart station shall be connected to the DUT to allow data communication during the measurement. The counterpart station shall be separated by a $5 \text{ k}\Omega$ resistor not to have an impact of the stations input impedance on the measurement.

- [V2G3-A11-10] The low-layer communication counterpart station shall comply with *[ISO-3]* regarding coupling circuit and transmission power.
- [V2G3-A11-11] A spectrum analyser with 50 Ω input impedance shall be connected to the communication line.
- [V2G3-A11-12] All passive components in the signal path shall be 50 Ω compliant parts and their insertion loss shall be taken into account.
- [V2G3-A11-13] During the whole measurement process, the DUT shall transmit with at least 20 % of the maximum data rate.
- [V2G3-A11-14] For the measurement of the PSD, the low-layer communication module shall support an operation mode which allows to transmit/receive without control pilot signal. Otherwise, the measurement resistance of 50 Ω will force an undefined state on the control pilot.
- [V2G3-A11-15] The measurement shall be compliant to the following procedure:
- a) The input attenuator of the spectrum analyser should be set in a proper way to avoid overloading the measurement device.
 - b) The instrument should be set to measure the peak power in a 9 kHz resolution bandwidth (dBm/9 kHz).
 - c) Record the whole carrier band from 1,8 MHz to 30 MHz with a hold time of at least 10 ms per sample point.
 - d) Determine the spectrum analyser's equivalent noise power bandwidth for the 9 kHz filter.
 - e) Calculate the power spectrum density for the DUT by taking the values obtained in step c and subtracting 10 log (equivalent noise power bandwidth/1 Hz).

NOTE The transmission power should be adapted through the HomePlug Green PHY chip prescaler to fit into the defined PSD limits.

A.11.5 Injection drawing example

Based on the signal and signal path specification above, the following clauses give an implementation example for the HomePlug Green PHY injection on the control pilot line.

The following schematic shows an implementation example based on the generic circuit in [Figure A.10](#).

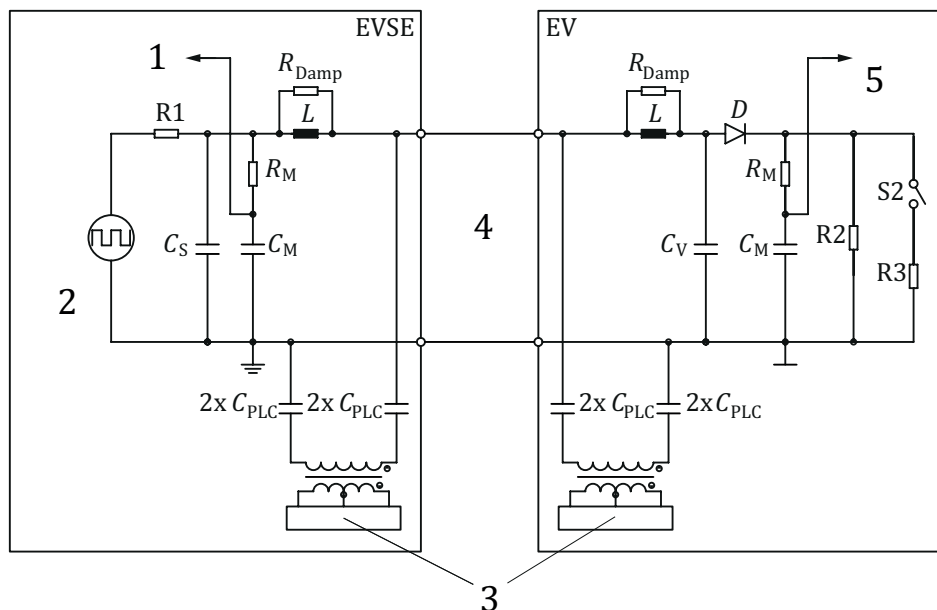

Key

- 1 amplitude/state measurement
- 2 oscillator $\pm 12\text{ V } 1\text{ kHz}$
- 3 PLC chipset
- 4 charge cord $C_c < 1\ 500\text{ pF}$
- 5 duty cycle measurement

Figure A.13 — Implementation example with a HomePlug Green PHY coupling transformer

For the implementation example in [Figure A.13](#), the component values defined in [Table A.12](#) should be applied.

Table A.12 — Component values of implementation example

Component	Value
R_1	[IEC-1]
R_2	[IEC-1]
R_3	[IEC-1]
R_M	10 k Ω
C_M	100 pF
C_V	[IEC-1]
C_S	[IEC-1]
C_{PLC}	1,35 nF
$T1/T2$	Example: 1:1:1 Coupling transformer (Depends on the chips and the TX / RX band-pass filter)
D	[IEC-1]
L	220 μH
R Damp	220 Ω

A.12 Layer 2 interfaces

A.12.1 IO control SAP

There are no additional requirements for the technology.

A.12.2 Data link data SAP

The Ethernet II-class SAP includes following service primitives, defined in the *[HPGP]*:

- ETH_SEND.REQ;
- ETH_SEND.CNF;
- ETH_RECEIVE.IND.

A.12.3 Data link control SAP to layer 3

There are no additional requirements for this technology.

Annex B (informative)

IEEE 1901.2 G3-PLC profile on control pilot line

NOTE This Annex has not been prepared by the project team responsible for the development of this part of ISO 15118.

B.1 Introduction

This part describes all requirements for the G3-PLC technology on CPLT. All requirements defined in this Clause are mandatory as soon as this Annex is deployed. G3-PLC profile is as referenced in IEEE 1901.2, Clause 9 with addition of FCC and ARIB bands supporting IEEE 1901.2, Clause 6 (Cenelec FCH in differential mode with future coherent option and supporting IEEE 1901.2 backward compatibility).

B.2 Normative references relevant for Annex B

The following referenced documents are indispensable for the application of this Annex. For dated references, only the edition cited applies. For undated references, the latest edition of the referenced document (including any amendments) applies.

IEEE 1901.2, *Standard for Low Frequency (less than 500 kHz) Narrow Band Power Line Communications for Smart Grid Applications*

ITU G.9903 Amd 1, *Narrow-band orthogonal frequency division multiplexing power line communication transceivers for G3-PLC networks*

B.3 Terms and definitions

For the purposes of this document, the following terms and definitions in addition to the terms and definitions given in [Clause 3](#).

B.3.1

IEEE 1901.2

Standard for Low Frequency (less than 500 kHz) Narrow Band Power Line Communications for Smart Grid Applications

B.3.2

ITU G.9903 Amd1

Narrow-band orthogonal frequency division multiplexing power line communication transceivers for G3-PLC networks

B.4 Symbols and abbreviations terms

ERDF	Electricité et Réseau de France
FCC	Federal Communications Commission
IEEE	Institute of Electrical and Electronics Engineers

ITU International Telecommunication Union
ARIB Association of Radio Industries and Businesses

B.5 Conventions applicable for Annex B

There are no specificities.

B.6 Software architecture

B.6.1 Specific overview for G3-PLC technology

This subclause is organized along architectural lines, emphasizing the large-scale separation of the system into two parts: the Media Access Control (MAC) sublayer of the data link layer and the physical layer. These layers are intended to correspond closely to the lowest layers of the ISO/IEC Model for Open Systems. [Figure B.1](#) shows the relationship of the ISO 15118 physical and data link layer to the OSI reference model.

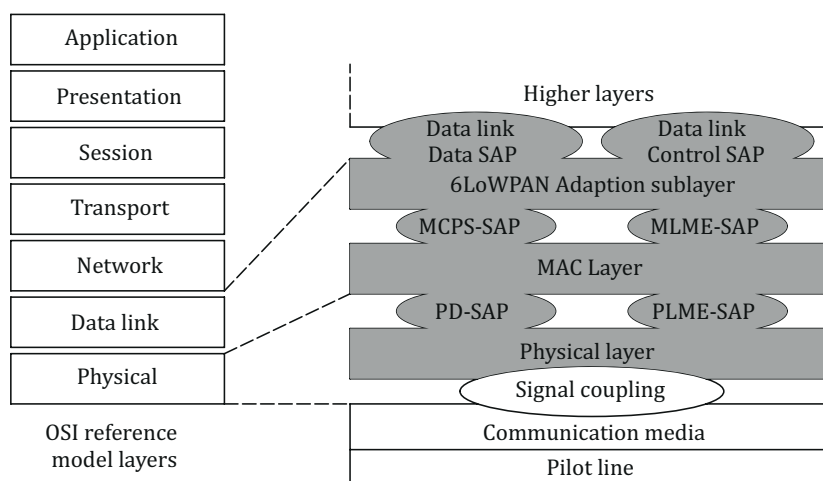

Key

■ covered by G3 specification

Figure B.1 — ISO 15118 physical and data link layer relationship to the ISO/IEC OSI reference model

B.6.2 Entity overview

B.6.2.1 Communication media

The physical media carrying the PLC signal is defined given by the cable assembly, which connects the power outlet and the EV.

B.6.2.2 Signal coupling

The signal coupling interface is defined in [B.9](#) and describes the method of coupling the low frequency PLC signal on the communication media.

B.6.2.3 PLC physical, MAC, and convergences layers

The grey colour entities represent the whole data link and physical layer and are covered by the G3-PLC PHY and G3-PLC MAC specifications.

B.7 Definition of high-level communication and basic signalling

There are no additional requirements for this technology.

B.8 Triggering

There are no additional requirements for this technology.

NOTE This technology does not require specific signals from the EVSE as it is a point-to-point technology that does not require association at the physical layer.

B.9 Association EV – EVSE procedure

B.9.1 Overview

The G3-PLC technology on CPLT is a point-to-point communication link that does not require specific association procedures for the physical link.

NOTE Association requires bi-directional information exchange. The low frequency of the G3-PLC technology and the low signal levels used on the CPLT render transfer to the mains impossible. It has been demonstrated that crosstalk from mains to pilot wire was detected above 11 Vp. This exceeds the allowed signal level.

B.9.2 Configuration of the PLC node

[V2G3-B09-01] The PLC node shall be configured in order to use the key “ISOIEC_15118-3” (TBD).

[V2G3-B09-02] The PLC node shall be configured in order to use the FCC frequency band.

NOTE 1 There is no need to exchange the frequencies used for communication since the use of the FCC frequency band on a medium (the pilot wire) which is decoupled from the Mains is not restricted. Additionally, the completion of IEEE 1901.2 and ITU G.9903 Amd1 define global emission limits beyond Cenelec for use in Europe and rest of world.

NOTE 2 Additional identifier can be added in the beacons to specify conformity to ISO 15118.

B.9.3 Discovery of the connected PLC module

[V2G3-B09-03] The “Discovery of the connected PLC module” macro bloc is not needed for G3 technology.

NOTE The G3PLC technology supports channel estimation features which allow each G3 PLC communication node to set up a neighbour table. The neighbour table gathers a list of essential parameters for each neighbour, including the Link Quality Indicator (LQI) which is based on SNR measurements. It is possible to define a threshold under which a note would not be considered as a neighbour and will have to be disassociated, however, this feature is not considered as necessary given the fact that the G3 PLC allows the establishment of a point-to-point link between and EVSE and the physically connected EV.

B.9.4 Validation of the identification of the PLC EVSE

[V2G3-B09-04] The validation of the identification of the PLC module on the EVSE side is not relevant for G3-PLC technology.

NOTE 1 The validation of the identification is not applicable for G3-PLC technology.

NOTE 2 In addition, it is possible to configure the PLC node to avoid any communication with a G3-PLC signal under a predefined value.

B.9.5 Set-up a logical network: 6LoWPAN Association procedure

The bootstrap of a private network using a public key between the EV and the EVSE shall be conformant to the following procedure:

- EVSE verifies the public key received from EV through the received beacons.
- After verification, EVSE assigns a group key to the EV.
- If not verified, EVSE denies EV Association.

B.10 EMC requirements

EMC requirements are specified as detailed in IEEE 1901.2, Clause 7 and IEEE 1901.2 EMC, Annex H

B.11 Signal coupling

[V2G3-B11-01] The coupling circuit shown in [Figure B.2](#) shall be used on the EVSE and the vehicle.

$R_1, C_1, C_2, R_2, R_3, S_1$ are indicated for information only and values as defined in IEC 61851-1:2010, Annex A shall be assumed to be already installed in the EVSE or EV. T2 represents the cable assembly between the EVSE and EV.

Lx1, Lx2, Rx1, and Rx2 are inserted in series with the pilot wire as shown on the [Figure B.2](#).

[V2G3-B11-02] Values of the inductances Lx1 (1 000 μ H), Lx2 (1 000 μ H), Rx1 (680 Ω), Rx2 (680 Ω), and coupling capacitors Cx1 (500 pF), Cx2 (500 pF) are mandatory. Rx3 (1 k Ω) and Rx4 (1 k Ω) are indicated as possible values of internal impedance of the transmitter. They are destined to limit the variation of the signal voltage on the pilot wire.

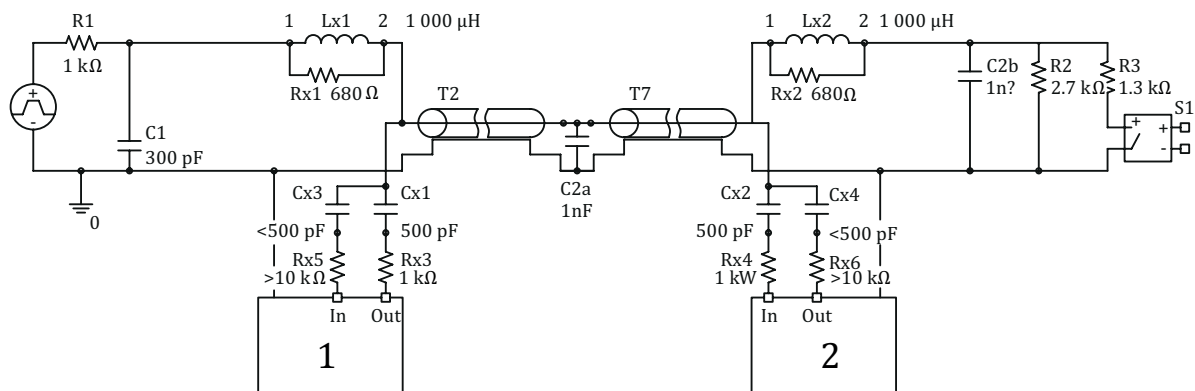

Key

- 1 modem on EVSE
- 2 modem on EV

Figure B.2 — Coupling circuit for G3 technology on pilot wire

[V2G3-B11-03] The values of the coupling components as shown in [Table B.1](#) are mandatory both on the EV and on the EVSE sides.

Table B.1 — Coupling components values

Group	Function	Mandatory values
A1, A2	Series impedance designed to avoid short circuiting of the High frequency high-level data carrier by EVSE or EV capacitors to ground	Lx1, Lx2 = 1 000 mH Rx1, Rx2 typically 680 Ω
B1, B2	Transmission matching impedance for high frequency signals	Circuit not implemented
C1, C2	Common mode rejection	Circuit not implemented
D1, D2	Capacitive coupling circuit Rx3, Rx4 = source resistance of HF output Rx5, Rx6 = optional input impedance of modem	— Cx1, Cx2 = 500 pF — Rx5, Rx6 > 10 kΩ — Cx5, Cx6 = 500 pF

[V2G3-B11-04] The PLC transmission devices shall limit the signal voltage on the pilot wire to 0.5 V RMS.

Further, decoupling circuits may be added to the pilot wire circuit.

Additional filtering components may be added to the EVSE power lines to improve reliability for specific environments and to ensure no more than an 0.5Vrms PLC signal on the PWM signal at the receiver.

[V2G3-B11-05] The signal voltage of the PLC transmission devices shall be at least on the pilot wire to 0,2 V RMS.

B.12 Layer 2 interfaces

B.12.1 Specific overview for G3-PLC technology

As shown in [Figure B.3](#), the G3-PLC technology covers both physical and data link layers and is based on a fully standardized PHY/MAC and 6LoWPAN stack.

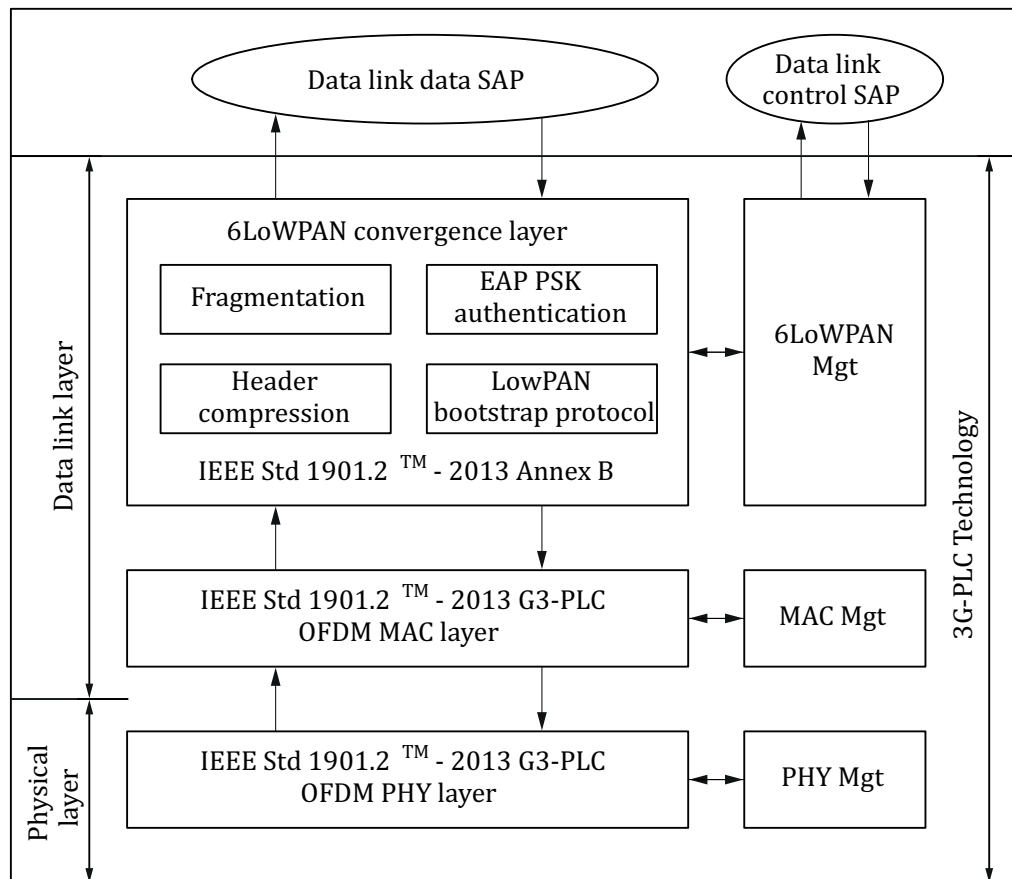

Figure B.3 — G3-PLC communication stack

The physical layer relies on an OFDM modulation operating in the FCC band. Channel estimation features enable the system to automatically adjust the modulation scheme to the channel conditions. ITU G.9903 Amd1 specifies the G3 physical layer as normatively referenced in IEEE 1901.2, Clause 9.

The G3 MAC sublayer is based on the IEEE 802.15.4 MAC standard CSMA/CA access method, quality of service, encryption, are the main features specified in ITU G.9903 Amd1. In addition, the 6LoWPAN convergence layer guarantees the support of IPv6 but also of authentication mechanisms during the network association phase which is totally managed by the lower layers. The usage which is made of RFC 4944 and RFC 6282 is fully described in ITU G.9903 Amd1.

NOTE If RFC 4944 specifies the compression of IPv6 (RFC 2460) and UDP (RFC 768) headers, IPv6 packets composed TCP (RFC 793) payloads and TCP plain headers are supported.

B.12.2 Data link data SAP

The interface to the higher layers consists in a set of generic primitives allowing the access to the lower layers in order to exchange data over the channel. The primitives are defined as follows:

- DATA-LINK_SEND.REQ: allows the higher layers to hand over to the lower layers the data to be transmitted over the medium;
- DATA-LINK_SEND.CNF: indicated to the higher layers whether or not the transmission was successful;
- DATA-LINK_RECEIVE.IND: informs higher layers that new data has been received.

B.12.3 Data link control SAP

There are no additional requirements for this technology.

All generic requirements are mandatory.

Bibliography

- [1] IEC 61851-23, *Electric vehicle conductive charging system — Part 23: DC electric vehicle charging station*
- [2] IEC 61851-24, *Electric vehicle conductive charging system — Part 24: Control communication protocol between off-board d.c. charger and electric vehicle*
- [3] IEC 62196-1:2011, *Plugs, socket-outlets, vehicle connectors and vehicle inlets — Conductive charging of electric vehicles — Part 1: General requirements*
- [4] IEC 62196-2:2011, *Plugs, socket-outlets, vehicle connectors and vehicle inlets — Conductive charging of electric vehicles — Part 2: Dimensional compatibility and interchangeability requirements for a.c. pin and contact-tube accessories*
- [5] IEC 62196-3, *Plugs, socket-outlets, vehicle couplers — Conductive charging of electric vehicles — Part 3: Dimensional compatibility and interchangeability requirements for d.c. and a.c./d.c. pin and contact-tube vehicle couplers*

British Standards Institution (BSI)

BSI is the national body responsible for preparing British Standards and other standards-related publications, information and services.

BSI is incorporated by Royal Charter. British Standards and other standardization products are published by BSI Standards Limited.

About us

We bring together business, industry, government, consumers, innovators and others to shape their combined experience and expertise into standards-based solutions.

The knowledge embodied in our standards has been carefully assembled in a dependable format and refined through our open consultation process. Organizations of all sizes and across all sectors choose standards to help them achieve their goals.

Information on standards

We can provide you with the knowledge that your organization needs to succeed. Find out more about British Standards by visiting our website at bsigroup.com/standards or contacting our Customer Services team or Knowledge Centre.

Buying standards

You can buy and download PDF versions of BSI publications, including British and adopted European and international standards, through our website at bsigroup.com/shop, where hard copies can also be purchased.

If you need international and foreign standards from other Standards Development Organizations, hard copies can be ordered from our Customer Services team.

Subscriptions

Our range of subscription services are designed to make using standards easier for you. For further information on our subscription products go to bsigroup.com/subscriptions.

With **British Standards Online (BSOL)** you'll have instant access to over 55,000 British and adopted European and international standards from your desktop. It's available 24/7 and is refreshed daily so you'll always be up to date.

You can keep in touch with standards developments and receive substantial discounts on the purchase price of standards, both in single copy and subscription format, by becoming a **BSI Subscribing Member**.

PLUS is an updating service exclusive to BSI Subscribing Members. You will automatically receive the latest hard copy of your standards when they're revised or replaced.

To find out more about becoming a BSI Subscribing Member and the benefits of membership, please visit bsigroup.com/shop.

With a **Multi-User Network Licence (MUNL)** you are able to host standards publications on your intranet. Licences can cover as few or as many users as you wish. With updates supplied as soon as they're available, you can be sure your documentation is current. For further information, email bsmusales@bsigroup.com.

BSI Group Headquarters

389 Chiswick High Road London W4 4AL UK

Revisions

Our British Standards and other publications are updated by amendment or revision.

We continually improve the quality of our products and services to benefit your business. If you find an inaccuracy or ambiguity within a British Standard or other BSI publication please inform the Knowledge Centre.

Copyright

All the data, software and documentation set out in all British Standards and other BSI publications are the property of and copyrighted by BSI, or some person or entity that owns copyright in the information used (such as the international standardization bodies) and has formally licensed such information to BSI for commercial publication and use. Except as permitted under the Copyright, Designs and Patents Act 1988 no extract may be reproduced, stored in a retrieval system or transmitted in any form or by any means – electronic, photocopying, recording or otherwise – without prior written permission from BSI. Details and advice can be obtained from the Copyright & Licensing Department.

Useful Contacts:

Customer Services

Tel: +44 845 086 9001

Email (orders): orders@bsigroup.com

Email (enquiries): cservices@bsigroup.com

Subscriptions

Tel: +44 845 086 9001

Email: subscriptions@bsigroup.com

Knowledge Centre

Tel: +44 20 8996 7004

Email: knowledgecentre@bsigroup.com

Copyright & Licensing

Tel: +44 20 8996 7070

Email: copyright@bsigroup.com



...making excellence a habit.™