

# Coal flow properties —

## Part 1: Bin flow

ICS 73.040

## National foreword

This British Standard reproduces verbatim ISO 15117-1:2004 and implements it as the UK national standard.

The UK participation in its preparation was entrusted to Technical Committee PTI/16, Solid mineral fuels, which has the responsibility to:

- aid enquirers to understand the text;
- present to the responsible international/European committee any enquiries on the interpretation, or proposals for change, and keep the UK interests informed;
- monitor related international and European developments and promulgate them in the UK.

A list of organizations represented on this committee can be obtained on request to its secretary.

### Cross-references

The British Standards which implement international publications referred to in this document may be found in the *BSI Catalogue* under the section entitled “International Standards Correspondence Index”, or by using the “Search” facility of the *BSI Electronic Catalogue* or of British Standards Online.

This publication does not purport to include all the necessary provisions of a contract. Users are responsible for its correct application.

**Compliance with a British Standard does not of itself confer immunity from legal obligations.**

### Summary of pages

This document comprises a front cover, an inside front cover, the ISO title page, pages ii to iv, pages 1 to 24, an inside back cover and a back cover.

The BSI copyright notice displayed in this document indicates when the document was last issued.

### Amendments issued since publication

Amd. No.	Date	Comments

This British Standard was published under the authority of the Standards Policy and Strategy Committee on 25 May 2004

© BSI 25 May 2004

ISBN 0 580 43813 9

INTERNATIONAL  
STANDARD

**ISO**  
**15117-1**

First edition  
2004-05-01

---

---

**Coal flow properties —**

Part 1:  
**Bin flow**

*Propriétés d'écoulement du charbon —*

*Partie 1: Écoulement d'une trémie*



Reference number  
ISO 15117-1:2004(E)



# Contents

Page

Foreword.....	iv
1 Scope.....	1
2 Normative references .....	1
3 Terms and definitions.....	1
4 Notation.....	4
5 Sampling and sample preparation .....	5
5.1 Sampling .....	5
5.2 Sample preparation.....	5
5.2.1 General .....	5
5.2.2 Sample top size .....	6
5.2.3 Sample division.....	6
5.2.4 Moisture content .....	6
6 Determination of yield locus.....	6
6.1 Apparatus.....	6
6.2 Instantaneous yield locus .....	6
6.2.1 General .....	6
6.2.2 Preconsolidation of the sample.....	7
6.2.3 Shear consolidation.....	8
6.2.4 Shearing of the sample.....	9
6.2.5 Determination of the complete family of instantaneous yield loci .....	10
6.3 Other yield loci .....	10
6.3.1 High-pressure yield locus .....	10
6.3.2 Time yield locus .....	10
6.3.3 Temperature yield locus.....	12
6.3.4 Vibration yield locus .....	12
6.4 Reporting and presentation of results.....	12
6.4.1 General .....	12
6.4.2 Prorating procedure.....	13
6.4.3 Determination of the instantaneous flow function .....	13
6.5 Acceptance of results and precision of the determination .....	14
7 Determination of wall yield locus .....	15
7.1 Principle .....	15
7.2 Apparatus.....	15
7.3 Sample.....	15
7.4 Procedure.....	15
7.5 Calculations .....	16
7.6 Determination of wall friction angle ( $\phi$ ).....	17
7.7 Precision of determination.....	17
8 Determination of bulk density/compressibility .....	18
8.1 General .....	18
8.2 Apparatus.....	18
8.3 Sample.....	18
8.4 Procedure.....	18
8.5 Calculations .....	19
8.6 Presentation of results .....	19
8.7 Precision of determination.....	19
Annex A (informative) Bin design philosophy.....	23

## Foreword

ISO (the International Organization for Standardization) is a worldwide federation of national standards bodies (ISO member bodies). The work of preparing International Standards is normally carried out through ISO technical committees. Each member body interested in a subject for which a technical committee has been established has the right to be represented on that committee. International organizations, governmental and non-governmental, in liaison with ISO, also take part in the work. ISO collaborates closely with the International Electrotechnical Commission (IEC) on all matters of electrotechnical standardization.

International Standards are drafted in accordance with the rules given in the ISO/IEC Directives, Part 2.

The main task of technical committees is to prepare International Standards. Draft International Standards adopted by the technical committees are circulated to the member bodies for voting. Publication as an International Standard requires approval by at least 75 % of the member bodies casting a vote.

Attention is drawn to the possibility that some of the elements of this document may be the subject of patent rights. ISO shall not be held responsible for identifying any or all such patent rights.

ISO 15117-1 was prepared by Technical Committee ISO/TC 27, *Solid mineral fuels*, Subcommittee SC 1, *Coal preparation: Terminology and performance*.

ISO 15117 consists of the following parts, under the general title *Coal flow properties*:

- *Part 1: Bin flow*
- *Part 2: Rapid assessment*

# Coal flow properties —

## Part 1: Bin flow

### 1 Scope

This part of ISO 15117 sets out methods for the measurement of the flow properties of coal, primarily for the design of bins and chutes. It also provides some guidance on the presentation of these data for analysis and design.

This part of ISO 15117 consists of a bulk density test and a yield locus test giving information on material flow properties. It also describes a further test, called the wall yield locus, which measures the friction between coal and bin wall material.

Although this part of ISO 15117 is nominally for coal, the principles and apparatus may be used for coke and other semi-cohesive particulate materials where a knowledge of flow properties is required.

NOTE Some discussion of the relevance of coal flow properties to bin design philosophy is provided in Annex A.

### 2 Normative references

The following referenced documents are indispensable for the application of this document. For dated references, only the edition cited applies. For undated references, the latest edition of the referenced document (including any amendments) applies.

ISO 1213-2:1992, *Solid mineral fuels — Vocabulary — Part 2: Terms relating to sampling, testing and analysis*

ISO 1953:1994, *Hard coal — Size analysis by sieving*

ISO 589:1981, *Hard coal — Determination of total moisture*

ISO 13909-2: 2002, *Hard coal and coke — Mechanical sampling — Part 2: Coal — Sampling from moving streams*

ISO 13909-4: 2001, *Hard coal and coke — Mechanical sampling — Part 4: Coal — Preparation of test samples*

ASTM D 6128-00, *Standard Test Method for Shear Testing of Bulk Solids Using the Jenike Shear Cell*

### 3 Terms and definitions

For the purposes of this document, the terms and definitions in ISO 1213-2 and those below apply.

NOTE In this part of ISO 15117, the terms pressure and stress are used synonymously because this convention is used in research and literature on this subject. Some other terms have not yet been standardized in the literature. These are listed below, together with a reference to the preferred nomenclature.

#### 3.1

##### **axi-symmetric flow**

SEE mass flow

**3.2**

**bulk density**

the mass of a sample of particulate solid including moisture, divided by its total volume

NOTE The level of consolidation stress is critical to any measurement of bulk density.

**3.3**

**bulk material**

semi-cohesive particulate material such as coal and other minerals

**3.4**

**cohesion**

the shear stress at yield under zero normal stress

NOTE This parameter is not normally quantified.

**3.5**

**compaction**

the process of permanent volume reduction of a bulk material by application of a consolidating stress

**3.6**

**consolidation**

SEE compaction

**3.7**

**core flow**

SEE funnel flow

**3.8**

**critical consolidation, in a shear cell**

the state existing in a bulk sample within a shear cell when the cell stem travel becomes independent of applied shear force

NOTE Under these conditions, the bulk material is deforming without change in voidage. The material is said to be in its critical state.

**3.9**

**critical state**

SEE critical consolidation

**3.10**

**critical pipe or rathole diameter**

the diameter of a rathole or pipe at which the rathole or pipe becomes unstable

NOTE The critical rathole diameter varies with consolidation pressures.

**3.11**

**effective angle of internal friction**

$\delta$

the angle with the horizontal axis of a line through the origin and tangent to the Mohr circle through the end point of the yield locus

See Figure 4.

NOTE The line through the origin is called the effective yield locus.

**3.12**

**expanded flow**

flow from a bin which has two distinct cross-section regimes

NOTE Funnel flow exists in the lower cylindrical section of the bin whereas mass flow exists in the conical outlet hopper or hoppers.



**3.13****flow function, instantaneous****FF**

for a given bulk material, a plot of the unconfined yield strength  $\sigma_c$  versus the major consolidating pressure, values being obtained from the yield loci

NOTE This is a measure of the bulk strength or flowability of a bulk material, in a de-aerated state, when first loaded into a bin or consolidated in a shear cell.

**3.14****flow function, time storage**

for a given bulk material, a measure of the increase in unconfined yield strength of material subjected to standard consolidation conditions for a defined time, typically 24 h to 48 h

**3.15****funnel flow**

the flow that occurs during gravity storage when bulk material sloughs off the surface of the material and discharges through a vertical channel which forms within the material in the bin whenever material is drawn from the outlet

NOTE Material adjacent to the bin walls remains stationary.

**3.16****hopper half-angle**

$\alpha$

the angle between one wall of the hopper and the vertical

**3.17****major consolidating pressure****major consolidating stress**

$\sigma_1$

the pressure given by the Mohr circle passing through the end point of the instantaneous yield locus and the tangent to the locus

See Figure 4.

**3.18****mass flow**

the flow that occurs when bulk material is in motion at every point in a bin whenever material is drawn from the outlet

NOTE Mass flow is normally symmetric and is usually axi-symmetric in three dimensions in a conical hopper, or plane in two dimensions in a wedge hopper.

**3.19****natural fines**

the fraction of the sample screened below 4 mm or 6 mm

**3.20****particulate solid**

an assembly of solid particles having properties independent of the number of particles present

SEE **bulk material** (3.3).

**3.21****plane flow**

SEE mass flow

**3.22**

**shear apparatus**

equipment for subjecting the material under test to shear deformation under conditions of controlled normal pressure

**3.23**

**unconfined yield strength**

$\sigma_c$   
the major principal stress that must be applied tangentially to an unconfined surface to cause yielding

**3.24**

**voidage or voids ratio**

the volume of the voids within a quantity of bulk material, divided by total volume (voids plus solids)

**3.25**

**yield locus, effective**

see effective angle of internal friction

**3.26**

**yield locus, instantaneous**

the shear force versus normal force curve for plastic failure of an over-consolidated bulk material of given initial voidage; this defines conditions when material flow commences

**3.27**

**yield locus, time**

the shear force versus normal force curve for plastic failure of a bulk material after being held at rest under a standard pressure for a given time

**3.28**

**yield locus, wall**

$\phi$   
the locus of shear force versus applied normal force on a sample of bulk material moving in contact with a boundary surface or wall

NOTE This is the angle determined by the shear and normal force shown in Figure 10.

## 4 Notation

The following quantity symbols are used in this part of ISO 15117:

- $F$  Unconfined yield force under instantaneous conditions
- $h$  Compacted height, in bulk density test
- $S$  Steady-state shear force during the “shear consolidation” phase of the shear test
- $S_f$  Steady shear force obtained in the wall friction test
- $S_t$  An uncorrected value of  $S$  determined from the shear test
- $S_s$  The value of  $S$  selected for a particular level of consolidation, and used for prorating  $(S_i)_t$  values
- $\bar{S}_i$  Maximum value of shear force obtained during the “sample shear” phase of the shear test
- $(\bar{S}_i)_t$  An uncorrected value of  $S$  determined from the shear test
- $(\bar{S}_i)_p$  A corrected value of  $S$  obtained using Equation (1)

$V$	Vertical force due to total vertical load applied at the shear plane during the “shear consolidation” phase of shear test X
	$V = V_a + V_b$
$V_a$	Vertical force due to the weight of the shear lid, shear ring and bulk solid above the shear plane, i.e. contained within the shear ring
$V_b$	Vertical force due to the weight applied to the shear lid during the “shear consolidation” phase of the shear test
$\bar{V}_{bi}$	Vertical force due to the weight applied to the shear lid during the “sample shear” phase of the shear test
$V_f$	Vertical force applied in the wall friction test
$\bar{V}_i$	Vertical force due to total vertical load applied at the shear plane during “sample shear” phase of the shear test
	$\bar{V}_i = V_a + \bar{V}_{bi}$
$V_t$	Vertical force due to the weight applied to the twisting lid during the “preconsolidation” phase of the shear test
$V_1$	Major consolidating force on sample
$W_f$	Weights used in the wall friction test
$W_h$	Mass of the weight hanger or carrier
$\sigma_c$	Unconfined yield strength (or stress) of a bulk solid
$\sigma_1$	Major consolidation pressure (or stress) of a bulk solid
$\phi$	Wall friction angle

## 5 Sampling and sample preparation

### 5.1 Sampling

The sample for flow property analysis shall be taken in accordance with ISO 13909-2. Care should be taken at all stages of sampling, sample handling and testing to prevent undue breakage.

Where test results are to be used for design of bins and transfer points, the material sampled should be related to the “problem” i.e., in the state that creates the most difficult flow conditions. For example, where the material breaks down with time and moisture, a weathered sample should be used.

### 5.2 Sample preparation

#### 5.2.1 General

Flow property measurements are carried out on the natural fines fraction of the sample. The top size of the fraction used shall be recorded.

The sample for testing shall be prepared by the methods given in ISO 13909-4. Sufficient sample shall be taken to yield at least 1 kg of the natural fines. If, however, time-delayed tests are to be carried out also, sufficient sample to yield 5 kg of minus 4 mm material is required.

### **5.2.2 Sample top size**

After drying, the sample shall be sieved according to the method set out in ISO 1953 to separate the natural fines. All tests shall be carried out on the minus 4 mm material occurring naturally in the sample.

### **5.2.3 Sample division**

Where necessary, the sample shall be divided by riffing or mechanical sample division to provide the required quantity for analysis. Dust loss and size degradation shall be minimized.

### **5.2.4 Moisture content**

In consideration of specific problems, the sample may need to be dry or at a predetermined moisture content.

The screened sample shall be at the required moisture content. The moisture contents of the initial sample and screened sample shall be measured before and after flow property testing, in accordance with ISO 589, and should not differ by more than 0,5 % on a mass basis. Samples should be stored in sealed containers to maintain moisture content. The moisture content of the natural fines in relation to the bulk sample shall be determined.

## **6 Determination of yield locus**

### **6.1 Apparatus**

A Jenike-type, direct shear tester having provision for the continuous display of shear/deformation using a chart recorder is required. Standard shear cells (see Figure 1) have internal diameters of 95 mm or 63,5 mm.

The lower ring is fixed to the frame and the upper ring is free to move under the action of the applied force. Ring movement is resisted by the material under test in the shear cell. To carry out the test, a twisting lid, shear lid, mould ring, twisting wrench, weight carrier, weights, spoon, scraper and brush are required. The standard deformation rate is  $(2,5 \pm 0,2)$  mm/min.

Where preconsolidation pressures are above 50 kPa, a cell of 63 mm nominal inside diameter cell is preferred. The shear cell of smaller diameter permits the higher pressures to be generated with smaller, more manageable normal loads. The cell diameter used should be a part of any statement of results.

NOTE Strict comparison is possible only on results from cells of the same dimensions.

### **6.2 Instantaneous yield locus**

#### **6.2.1 General**

The instantaneous yield locus is determined using the 95 mm low pressure cell (see 6.1). The shear cell shall be filled with a fresh sample for each test.

To ensure that the cell material is critically consolidated when measurements are made, the limited travel in the Jenike cell necessitates an iterative trial-and-error consolidation procedure. Critical consolidation is the point where cell stem travel is first independent of shear force as shown in Figure 3, curve B.

The trial-and-error procedure shall approach critical consolidation from below rather than above, as the latter can lead to erroneous results (see Figure 3, curve C, point X).

### 6.2.2 Preconsolidation of the sample

Place the cell base, shear ring and mould ring on the shear tester (see Figure 1). Adjust the offset of the shear ring to approximately 3 mm.

Place a sample of the material to be tested in the shear cell, layer by layer, each layer being spread lightly and uniformly with a spoon, taking care not to leave impressions which could lead to preferential shear planes. Scrape off excess material flush with the top of the mould ring. Cover the material with the twisting lid.

Apply a vertical force,  $V_t$ , to the twisting lid by means of a weight carrier, and, by using the special twisting wrench, apply a number of oscillating twists (amplitude approximately  $\pm 20^\circ$ ) to the lid. During this procedure, care should be taken not to press down on the twisting lid and not to impede the motion of the shear ring, as it tends to follow the motion of the twisting lid.

Select the value of  $V_t$  and the number of twists to be applied by trial and error. For most dry samples,  $V_t$  is made equal to  $V$ , the normal force used in the consolidation-under-shear procedure described below. However, for high moisture samples, values of  $V_t$  equal to 2 to 4 times  $V$  may be required. The number of complete twists applied initially is about 20.

Remove the weight carrier from the twisting lid.

Lift off the mould ring while holding down the twisting lid and shear ring.

Slide the twisting lid off and scrape off the excess material flush with the top of the shear ring. In these operations, care should be taken to avoid any movement of the shear ring. Clean away excess material with the brush.

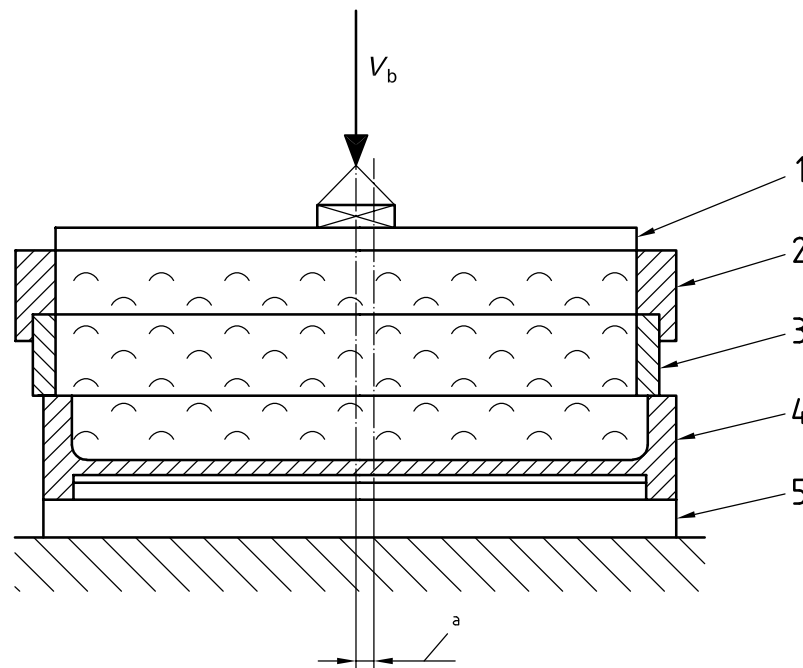

#### Key

- 1 twisting lid
- 2 mould ring
- 3 shear ring
- 4 base
- 5 frame
- a Offset.

Figure 1 — Jenike shear cell — Set-up for preconsolidation

### 6.2.3 Shear consolidation

Consolidation of the sample is completed by a shearing operation, which causes the material to flow under the consolidating stresses until a steady-state shear value is reached, or closely approached.

Place the shear lid on the sample, taking care to centre it within the shear ring, and ensure that the drive bracket is aligned with the transducer stem. Apply the force,  $V_b$ , to the lid using an appropriate weight, and advance the stem of the direct shear tester against the bracket (see Figure 2).

Allow shearing to proceed until a condition is reached where a layer of the material across the whole sample is caused to flow plastically, and the recorded shear force reaches a steady value,  $S$ . Ideally, this steady value of shear force should be reached when the shear ring is concentric with the base of the cell.

Reverse the stem travel until the shear force drops to zero. Then remove the force,  $V_b$ .

It is important that the steady-state shear force,  $S$ , is reached as indicated by curve B, Figure 3; the sample is then critically consolidated. If the shear force continues to rise for the complete stem travel (curve A, Figure 3), the sample was under-consolidated during the preconsolidation phase. Generally, this means that an increase is needed in the preconsolidation force,  $V_t$ , or the number of twists used. If the shear force reaches a maximum then reduces (curve C, Figure 3), the sample was over-consolidated during the preconsolidation phase. Generally, this means that either the value of  $V_t$  or the number of twists was excessive. If either of these conditions occurs, the test should be repeated.

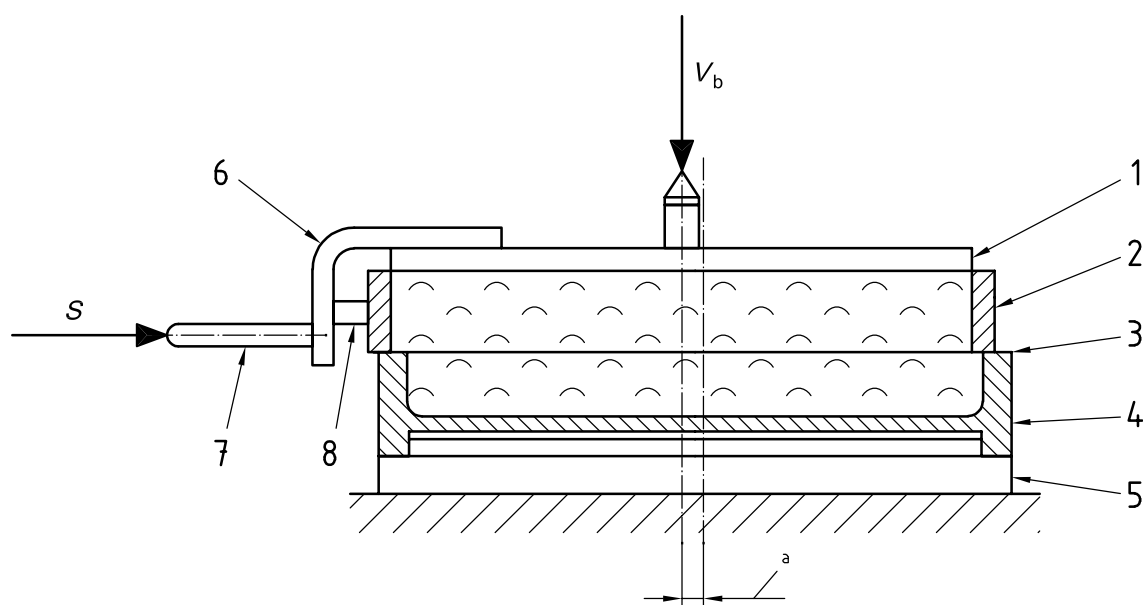

Key	
1	shear lid
2	shear ring
3	shear plane
4	base
5	frame
6	bracket
7	loading stem
8	pin
a	Offset.

Figure 2 — Jenike shear cell — Set-up for shear consolidation

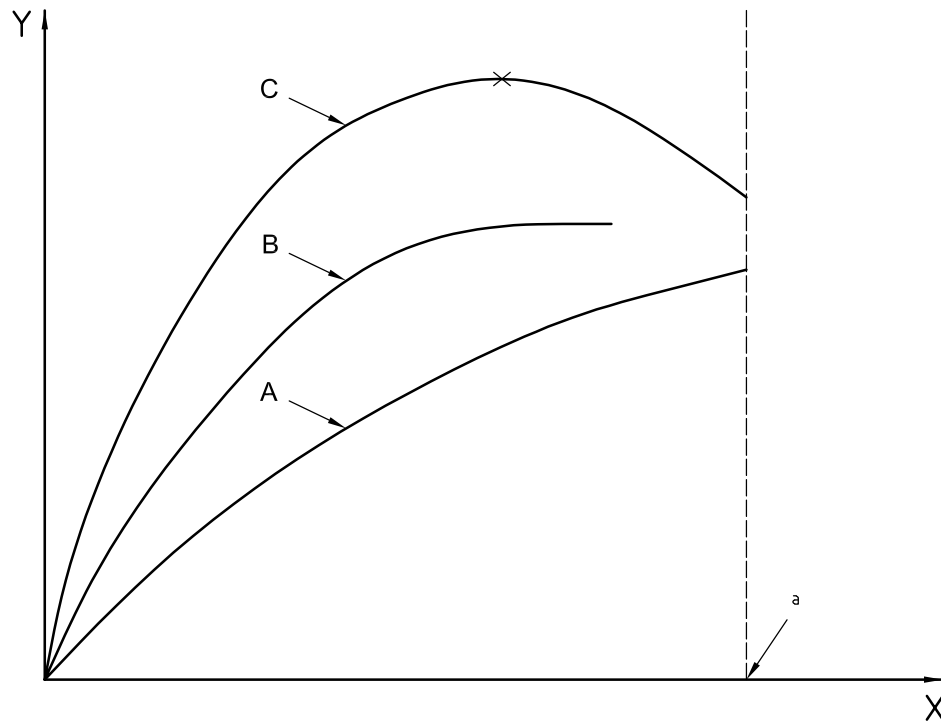
**Key**

- A under-consolidated
- B critically consolidated
- C over-consolidated
- X Stem travel
- Y Shear force,  $S$  (N)
- <sup>a</sup> Limit of travel.

**Figure 3 — Types of shear consolidation curve**

#### 6.2.4 Shearing of the sample

The third stage of the test is the actual shearing of the sample under force  $\bar{V}_i$ , smaller than  $V$ . The procedure shall be as given below.

Apply force ( $\bar{V}_{bi}$ ) to the shear lid.

Advance the stem of the machine until it almost touches the bracket.

Let shearing proceed until the recorder pen reaches and passes a maximum value,  $\bar{S}_i$ .

Retract stem and remove force,  $\bar{V}_{bi}$ .

Remove the entire cell including the shear lid and split the shear ring and base apart. Striking the lid or bottom of the cell, check to see that the shear plane is between the ring and the base and not angled up or down. If the shear plane is not correct, the complete test shall be repeated.

Once for each level of consolidation, determine the additional vertical force ( $V_a$ ) above the shear plane.

- NOTE  $V_a$  is the vertical force due to
- a) shear lid,
  - b) shear ring, and
  - c) mass of material contained within the ring.

### 6.2.5 Determination of the complete family of instantaneous yield loci

Repeat the entire three-stage procedure two more times for the same level of consolidation, applying the force,  $V_b$ , to the shear lid during shear consolidation by applying forces  $\bar{V}_{b2}$  and  $\bar{V}_{b3}$  to the lid during shear. A sample of fresh material is used for each test. This set of results will be used to provide one complete yield locus.

Perform a complete series of tests at two other levels of consolidation, one higher and one lower than the first level. Thus, the minimum number of valid tests which are performed to obtain the family of instantaneous yield loci is nine.

NOTE In order to clarify the procedure and to illustrate with numerical values, an example is set out in 6.4.3, using a coal at 10 % total moisture content. This example gives an idea of the forces needed to be applied to the shear lid for the nine tests required. In the selection of vertical forces, care should be taken that all results lie in the valid range, as indicated in Figure 4. The numerical values used later are set out in Table 1.

Table 1 — Yield locus raw test results for 10 % moisture coal

Values in newtons

Applied force	High consolidation			Medium consolidation			Low consolidation		
	Test 1	Test 2	Test 3	Test 1	Test 2	Test 3	Test 1	Test 2	Test 3
$V_b$	31,4	31,4	31,4	22,6	22,6	22,6	13,7	13,7	13,7
$V_a$	3,8	3,8	3,8	3,6	3,6	3,6	3,4	3,4	3,4
$V = V_b + V_a$	35,2	35,2	35,2	26,2	26,2	26,2	17,1	17,1	17,1
$S$	33,5	34,0	32,0	24,5	26,0	22,9	15,8	16,9	15,7
$S_s$	33,0	33,0	33,0	24,5	24,0	24,5	16,0	16,0	16,0
$\bar{V}_{bi}$	17,7	13,8	7,8	12,8	8,8	3,9	6,9	4,9	2,9
$\bar{V}_i = \bar{V}_{bi} + \bar{V}_a$	21,5	17,6	11,6	16,4	12,4	7,5	10,3	8,3	6,3
$(\bar{S}_i)_t$	25,9	22,3	17,2	19,4	17,3	11,7	12,3	11,6	9,3
$(\bar{S}_i)_p$	25,5	21,6	17,7	19,4	16,3	12,5	12,3	11,0	9,5

### 6.3 Other yield loci

In all cases the instantaneous yield loci are measured. Specific needs may require other additional loci to be measured.

#### 6.3.1 High-pressure yield locus

When the high-pressure yield locus is required, the instantaneous yield locus test is repeated using a shear cell of 63 mm nominal inside diameter when the consolidation pressure is greater than 50 kPa.

#### 6.3.2 Time yield locus

After completing an instantaneous yield locus test, it is possible to carry out a time yield locus test at the same consolidation level as in the original tests, as shown below.

Repeat the test up to the point where the sample would be consolidated under shear.

Transfer the cell to a consolidation bench and load with a normal force equivalent to the major consolidation pressure derived from the instantaneous locus, left for the specified period. This is a simple bench allowing for a number of tests with different loads to be carried out concurrently (see Figure 5).



Protect the sample from drying out during this time.

At the conclusion of the required period, return the cell to the direct-shear apparatus, and shear to obtain a point on the time yield locus.

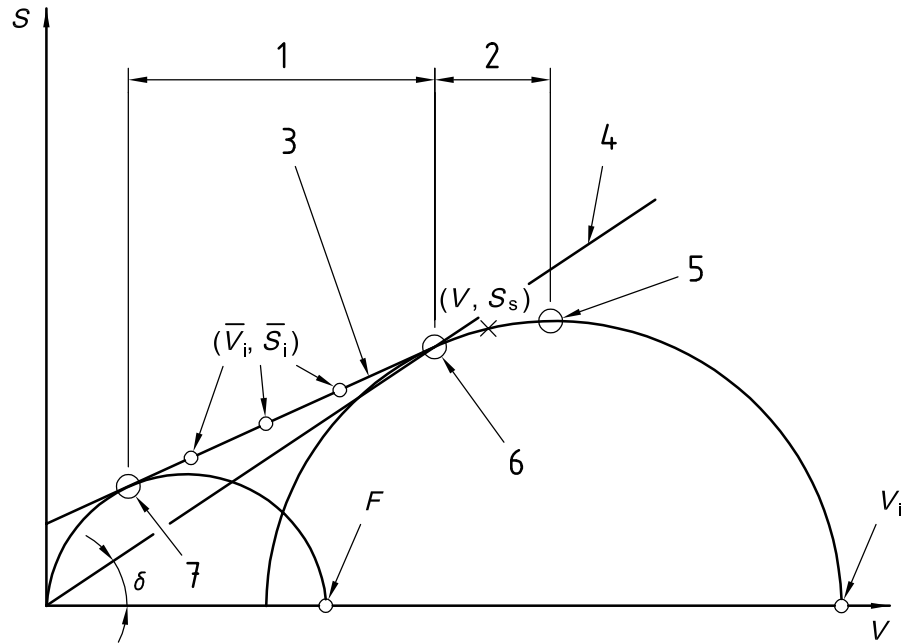

**Key**

S Shear force, (N)  
 V Normal force, (N)

- |   |                            |
|---|----------------------------|
| 1 range of valid yield locus points         | 5 top of Mohr circle       |
| 2 range of valid shear consolidation points | 6 end point of yield locus |
| 3 instantaneous yield locus                 | 7 tangency point           |
| 4 effective yield locus                     |                            |

**Figure 4 — Valid range of points for instantaneous yield locus**

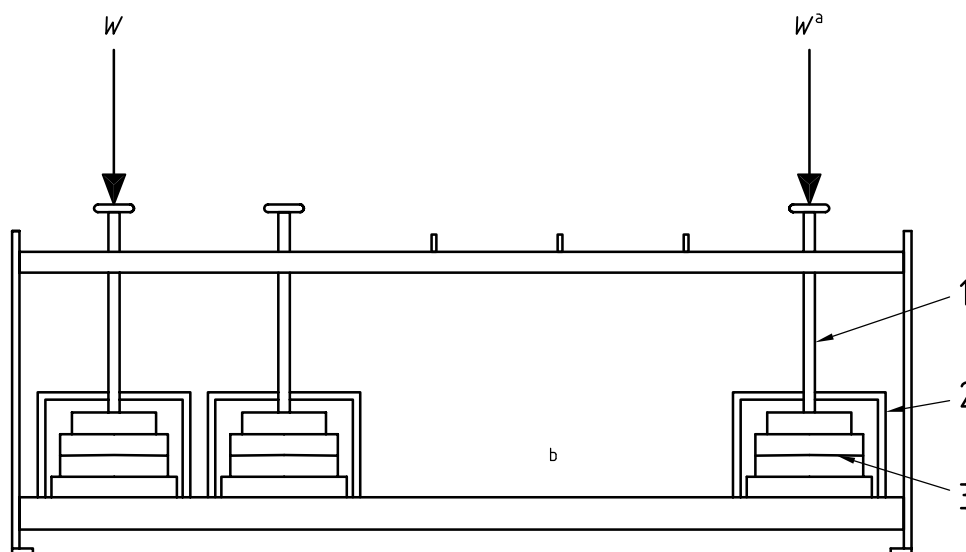
**Key**

- 1 loading stem
- 2 cover to preserve environment
- 3 consolidated sample

a Applied load.

b Extra 6 cells.

**Figure 5 — Consolidation bench**

### 6.3.3 Temperature yield locus

The instantaneous and time shear tests may be performed at a desired temperature to simulate actual conditions.

### 6.3.4 Vibration yield locus

The instantaneous and time shear tests may be performed at a desired level of vibration, at right angles to the direction of movement of the shear cell, to simulate actual conditions.

## 6.4 Reporting and presentation of results

### 6.4.1 General

The interpretation of the test results from the determination of a family of yield loci, such as is shown in Figure 6, requires observance of some fundamental principles. The following rules shall be obeyed.

- a) Loci shall not intersect.
- b) The force due to the weight of the shear lid, shear ring and material contained in the shear ring ( $V_a$ ) shall be added to all vertical forces applied to the shear cover ( $\bar{V}_{bi}, V_b$ ), to obtain the total vertical force applied to the shear plane.
- c) The yield loci data shall fall within the valid range defined in Figure 4, and vary only within defined bounds.

The following principles should also be observed.

- Samples should be critically consolidated.
- In general, loci should be drawn as straight lines.

- Loci should be parallel, or fan out slightly as the normal load (or stress) increases.
- The shear consolidation point may not necessarily correspond to the end point of the yield locus.
- The shear consolidation points should generally lie close to a straight line that passes either through or above the origin.
- The smoothing or prorating procedure of Jenike works well for instantaneous yield locus test shear force results (see 6.4.2).
- The yield loci may be plotted in either force or stress units. For convenience, it is recommended that force units be used for the initial plot of results, although stress units are recommended for the final presentation of data. Where the yield loci are plotted in force units, it is necessary to indicate the diameter of the shear cell used.

#### 6.4.2 Prorating procedure

When determining a yield locus, the values of shear force,  $S$ , obtained during the shear consolidation process will usually show some scatter. The allowable deviation of  $S$  from the intermediate value is less than 5 %, and the following relationship should be used to adjust or prorate the raw test results:

$$\left(\bar{S}_i\right)_p = \left(\bar{S}_i\right)_t \frac{S_s}{S_t} \quad (1)$$

The value of  $S_s$  should be an intermediate value within the range of scatter of the  $S_t$  values; an average value of all the  $S_t$  values may be satisfactory. As a guide, when prorating  $\left(\bar{S}_i\right)_t$  values for a family of yield loci, the  $S_s$  values should lie close to a straight line that passes through or above the origin.

As an example of prorating procedure, the data of Table 1 represent a series of yield-locus raw test results for 10 % moisture content, and their subsequent prorating.

The resulting values of the yield loci [ $V$ ,  $S_s$  and  $V_1$ ,  $\left(\bar{S}_i\right)_p$  values for each level of consolidation] are plotted in Figure 6.

#### 6.4.3 Determination of the instantaneous flow function

Once the yield loci have been plotted, Mohr stress circles can be drawn for each locus (see Figure 4).

Draw a semicircle, centred on the normal force axis, to pass through the point  $V$ ,  $S_s$  (marked X) and to be tangential to the yield locus. This is referred to as the steady-state Mohr circle of flow, and describes the consolidation condition for the locus.

Draw a semicircle, centred on the normal force axis, to pass through the origin and to be tangential to the yield locus. This is referred to as the unconfined Mohr circle, and describes the unconfined yield strength of the bulk solid for the consolidation level of the yield locus.

NOTE Because circles are being drawn on the instantaneous yield locus graph, it is implied that the same scale has been used for the horizontal and vertical axes.

These Mohr circles provide three combinations of major consolidation force ( $V_1$ ) and unconfined yield force ( $F$ ).

For the example using values provided in Table 1 and the corresponding yield loci plotted in Figure 6, these values are as follows:

	$V_1$ , newtons	$F$ , newtons
High consolidation	78,9	35,2
Medium consolidation	58,2	27,9
Low consolidation	37,6	19,1

These forces can be converted to stresses by dividing by the cross-sectional area of the shear cell. This area is 0,007 13 m<sup>2</sup> for the 95,3 mm diameter cell.

This conversion changes the major consolidation force ( $V_1$ ) to major consolidation stress ( $\sigma_1$ ) and the unconfined yield force ( $F$ ) to unconfined yield stress ( $\sigma_c$ ), and the corresponding values in the example become:

	$\sigma_1$ , kPa	$\sigma_c$ , kPa
High consolidation	11,0	4,9
Medium consolidation	8,2	3,8
Low consolidation	5,3	2,7

These values are plotted in Figure 7 to provide the instantaneous flow function.

Generally, the instantaneous flow function can be drawn as a slight curve or a straight line of best fit through the three plotted points. The flow functions, when extended, should pass through or above the origin of the graph.

NOTE The same scale is to be used for the horizontal and vertical axes.

### 6.5 Acceptance of results and precision of the determination

For reliable design applications, the shear consolidation value shall be within 5 % of the value selected for prorating. Provided that the shear plane conforms to the split plane of the shear cell, the test points should be accepted. For design applications, the concept of “worst case that could reasonably be expected” applies. A full series of points should be obtained and a family of curves drawn about these to obtain consistent results. Drawing individual and independent instantaneous or time yield loci should be avoided.

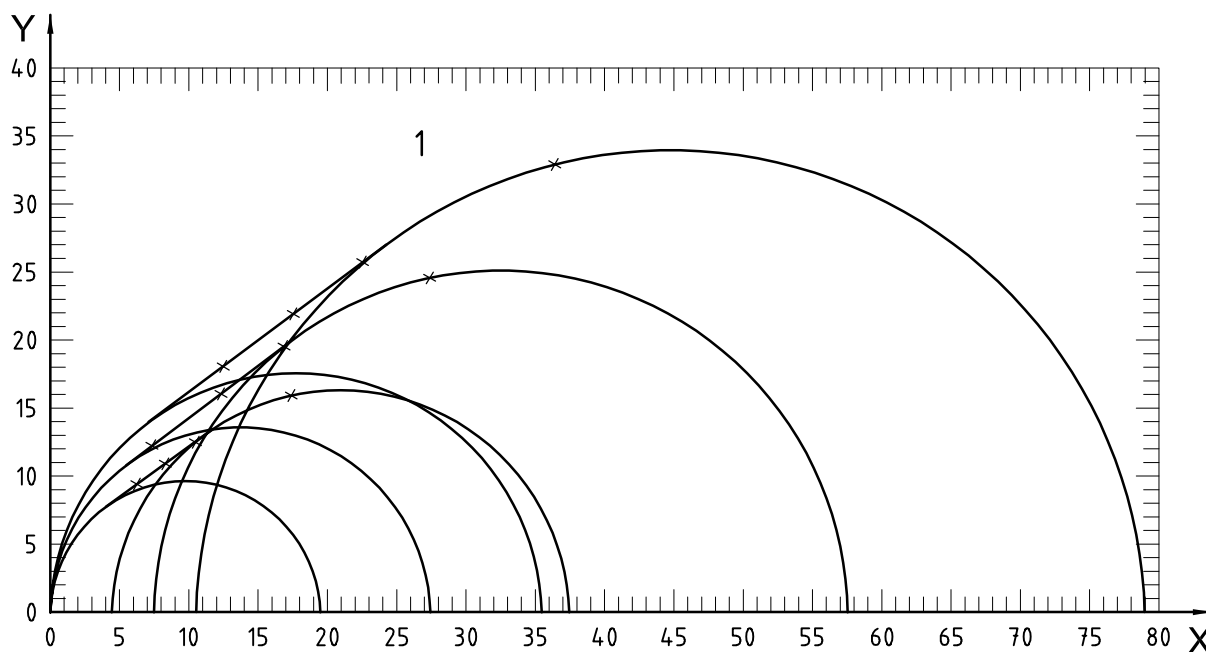

**Key**

- X Normal force (N)
- Y Shear force (N)
- 1 area of shear cell = 0,007 13 m<sup>2</sup>

Figure 6 — An example of a family of instantaneous yield loci

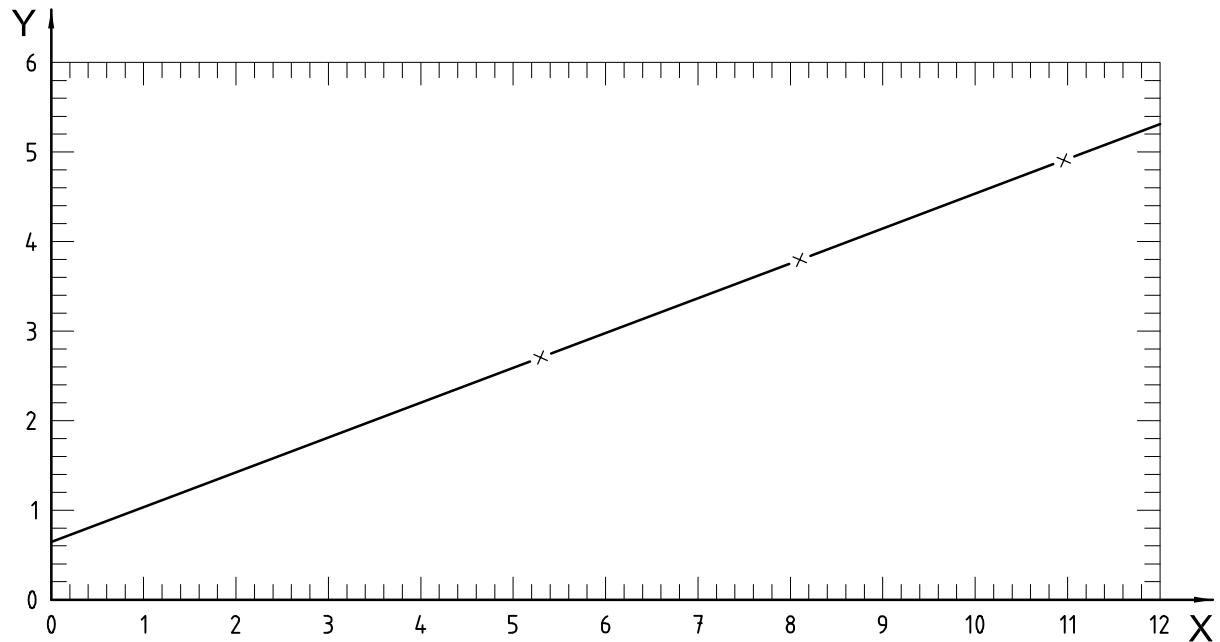
**Key**

- X Major consolidation stress (kPa)
- Y Unconfined yield stress (kPa)

**Figure 7 — An example of instantaneous flow function**

## 7 Determination of wall yield locus

### 7.1 Principle

The wall yield locus test is used to determine the effect of likely bin wall materials on coal flow properties. It is measured over the range of pressures expected to act at the walls of a hopper. Five to seven points are normally determined. The weights are selected to form a stack so that all the values of  $W_{fn}$ , from  $n = 0$  to  $n = 5$  or 7, can be successively applied by removing weights from the top of the stack.

**NOTE** The process of removing normal loads during the wall yield locus test is consistent with the pressure-versus-flow characteristics in a hopper. As the bulk solid flows toward the hopper outlet, the pressure is reduced.

### 7.2 Apparatus

The apparatus is shown in Figure 8.

### 7.3 Sample

The coal sample shall be obtained using the method described in Clause 5. The wall material shall be representative of the wall against which the coal is expected to slide.

### 7.4 Procedure

Wash and dry the wall material sample thoroughly. Do not touch the cleaned surface with bare hands. Rub some of the coal sample into the surface of the wall material sample to precondition it.

Retract the stem.

Shim the wall material sample, so that the top surface of the sample is in a plane with the centre-line of the stem (see Figure 8). Place the ring on the wall material sample and set it against the locating screws. Adjust the position of the wall material sample so that it just covers the inside of the ring on the stem side. This will permit maximum travel of the ring over the wall material sample during the tests. Fix the position of the wall sample with the stop.

Place the mould on the ring and fill the ring and mould with the solid. Scrape off the excess solid flush with the top of the mould. The scraping motion should be directed toward the locating screws. Cover the solid with the twisting top. Place the weight hanger on the twisting top. Place weight,  $W_{f0}$  on the hanger.

The largest initial weight,  $W_{f0}$ , should approximately equal the major consolidating force,  $V_{lu}$  of the highest yield locus level. The subsequent weights,  $W_{fn}$ ,  $n = 1$  to 5 or 7, should decrease stepwise to zero.

By means of the twisting wrench, apply 30 alternating twisting cycles of about 20 degrees of arc (each way from the starting position) to the twisting top. Apply no extra pressure to the top. During twisting, hold the ring firmly against the locating screws. However, allow the mould to twist freely. Carefully remove the weight hanger and weight,  $W_{f0}$ , from the twisting top. Holding down the twisting top, carefully remove the mould. Remove the twisting top from the cell with a sliding motion towards the locating screws.

Scrape off the solid level with the top of the ring. The scraping motion should be directed toward the locating screws. Place a shear cover on the solid and stack weights, totalling  $W_{f0}$ , either directly on the cover or on the weight hanger.

NOTE If the hanger is used, weight,  $W_{f0}$ , includes the weight of the hanger,  $W_h$ .

Twist and lift the ring slightly off the wall sample, to prevent it from dragging on the sample. Set the advance of the stem. When the shear force,  $S_{f0}$ , has levelled off, remove weights, as needed, to reduce the applied weight to  $W_{f1}$ . Do not stop the motion of the stem. Ignore force  $S_{f0}$ . When the shear force has again levelled off, record force  $S_{f1}$ , and remove more weights to reduce the applied weight to  $W_{f2}$ . When the shear force has again levelled off, record  $S_{f2}$ . Continue the procedure over the range of weights,  $W_{fn}$ , and record force  $S_{fn}$ .

If the forward motion of the stem runs out before all the specified weights have been tested, retract the stem, push the ring back carefully to the locating screws, and back off one test step by replacing the weight last removed. If the  $S_f$  values produced are significantly lower than previously recorded, repeat the test using a new sample and the same  $W_{f0}$  and  $W_{fn}$  values required to complete the test, and prorate the results.

After completion of the test, weigh the cover, ring and enclosed solid to provide the value of  $W_0$ .

## 7.5 Calculations

The wall yield locus is calculated as follows:

Calculate the total vertical forces from the following equation:

$$V_{fn} = 9,8 C(W_0 + W_{fn}) \quad (2)$$

where

$C = 1$  in tests with the 95 mm cell, and

$C = 2,25$  in tests with the 63,5 mm cell

and  $W_0$  and  $W_{fn}$  are in kilograms.

Correct the shear force for different cells by multiplying  $S_{fn}$  by the relevant  $C$  above.

Using  $V$  and  $S$  as coordinates, plot points  $(V_{fn}, S_{fn})$  and draw a smooth curve through the points (see Figure 9). This is the wall yield locus, WYL, of the solid on the wall material. In their final form, wall yield loci generally are drawn in stress units (see 6.4.3 for conversions).

## 7.6 Determination of wall friction angle ( $\phi$ )

Wall friction angle,  $\phi$ , usually varies with consolidating pressure level. Figure 10 shows the results for determining the value of  $\phi$  for any particular consolidation level,  $V_1$ .

For converging channels, i.e. for hoppers, use the higher point of intersection. Draw a straight line through the origin and the chosen point of intersection.

The straight line forms an angle with the  $V$ -axis. This is the angle of wall friction at a major consolidating force,  $V_1$ , for converging flow.

## 7.7 Precision of determination

The results shall be repeatable within 5 %.

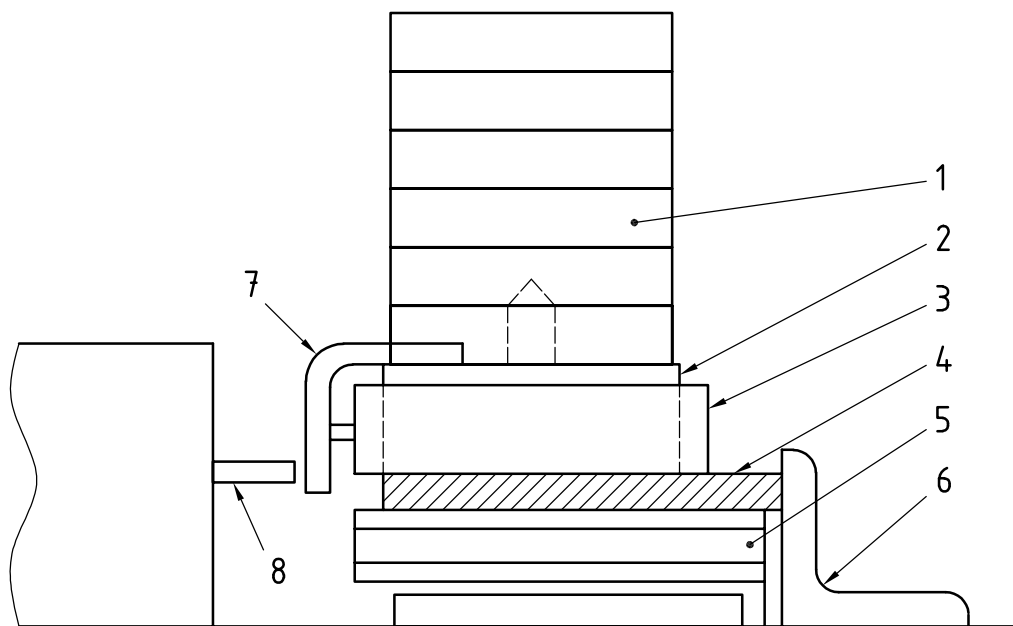

### Key

1	weights	5	shims
2	shear lid	6	stop
3	shear ring filled with coal	7	bracket
4	wall material sample	8	stem

Figure 8 — Apparatus for wall yield locus

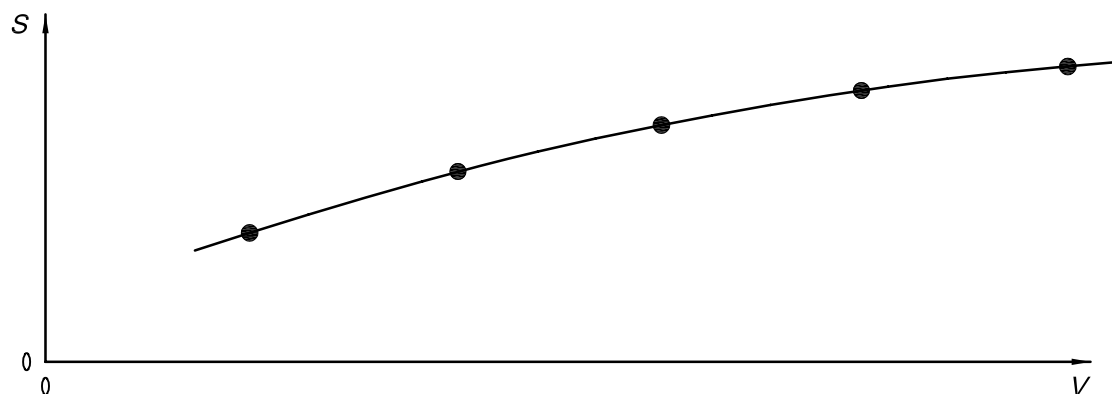
**Key**

$V$  Normal force (N)

$S$  Shear force (N)

**Figure 9 — Wall yield locus**

## 8 Determination of bulk density/compressibility

### 8.1 General

For the design of a bulk handling plant, it is useful to have the relation between bulk density and major consolidation stress.

### 8.2 Apparatus

An apparatus based on a Jenike compressibility tester<sup>1)</sup> developed to perform this measurement is shown in Figure 11. The cell used has dimensions of 63,5 mm inside diameter and 19 mm internal depth and is fitted with a twisting cover. The ring has a base and a close fitting internal lid/weight carrier as shown. Weights can be added and the degree of compression measured with a dial indicator.

### 8.3 Sample

The sample of the natural fines shall be obtained using the method described in Clause 5.

### 8.4 Procedure

Before filling the cell, place it on a base which prevents its rotation. Spoon the material into the cell to overflowing, taking care not to pack the material during the process. Carefully scrape excess material flush with the top of the cell.

Place the twisting cover on the material, checking its alignment with the rim of the cell. Ensure that the top surface of the cell around the cover is clean and that the counterbore of the indicator holder is clean. Place the indicator holder on the cell, being careful not to exert force on the cover.

1) Shear cells are available from a number of sources. More detailed information regarding the dimensions and operation of the shear cells is available in ASTM D6128.



Insert the twisting bar into the hole provided in the cover and apply 30 complete twists  $\pm 15^\circ$  within the amplitude allowed by the indicator holder to reach a stable dial gauge reading indicating that a critical state of consolidation has been obtained. Be careful not to provide extra vertical force with the twisting bar.

Record the compacted height,  $h$ , and the weight of the cover and carrier, i.e. the applied force.

Repeat the procedure described in paragraphs 4 and 5 above with a series of weights as follows.

- a) Remove the indicator holder and place the weights on the cover.
- b) Refill the cell preferably with fresh sample.
- c) Clean the top surface of the cell and the counterbore of the indicator holder and place the holder on the top surface of the cell.
- d) Repeat the procedure outlined in paragraphs 4 and 5.
- e) Repeat again, successively placing 0,5 kg, 1 kg, 2 kg, 4 kg, 8 kg and 16 kg masses on the mass carrier.

Weigh the cell full and empty, to determine the mass of material in the cell.

### 8.5 Calculations

The bulk density and major consolidation pressure are calculated as follows.

Calculate the bulk density, in  $\text{kg/m}^3$ , for each value of vertical force from the following equation:

$$\text{bulk density} = \frac{\text{mass of material in cell}}{\text{area of cell} \times \text{compacted height, } h} \quad (3)$$

Calculate the major consolidation pressure,  $\sigma_1$ , from the following equation:

$$\sigma_1 = \frac{\text{applied force (newtons)}}{\text{area of cell (m}^2\text{)}} \quad (4)$$

### 8.6 Presentation of results

Bulk density is plotted against major consolidation force or stress to give a plot as shown in Figure 12.

### 8.7 Precision of determination

The results shall be repeatable within 5 %.

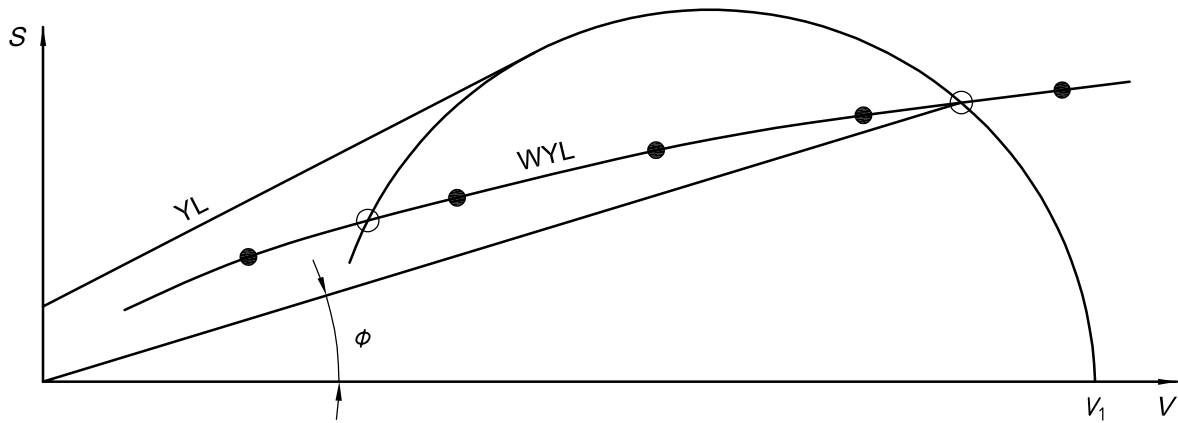

**Key**

- $V$  Normal force (N)
- $S$  Shear force (N)
- YL Yield locus
- WYL Wall yield locus

**Figure 10 — Yield loci**

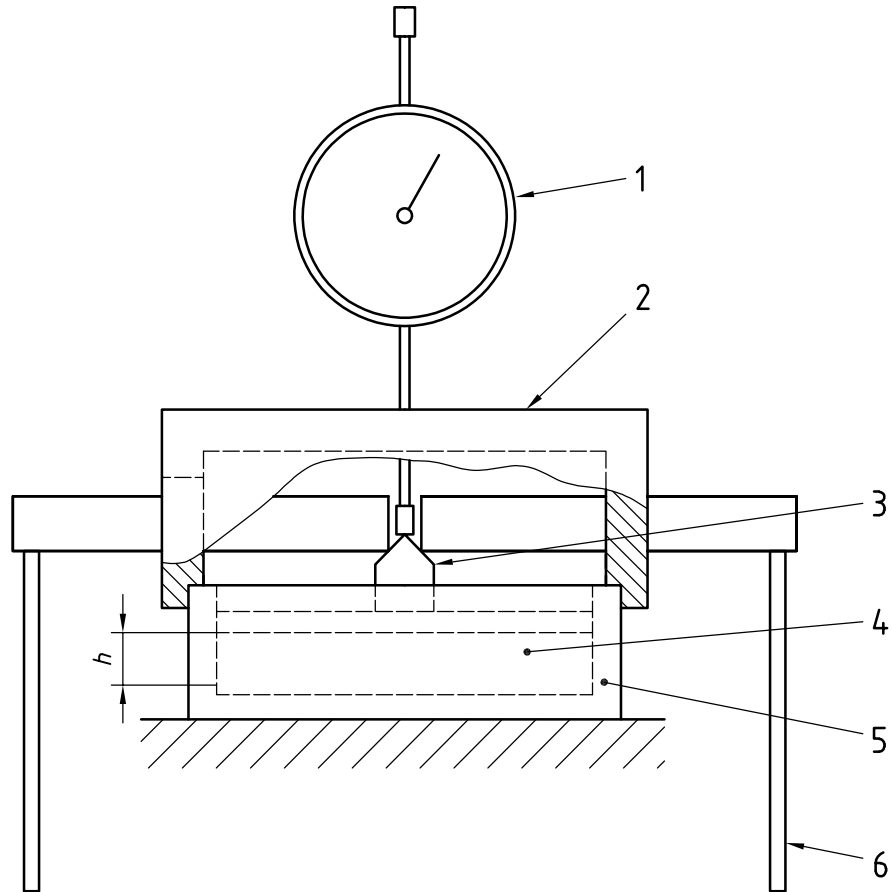
**Key**

- 1 Dial indicator
- 2 Indicator holder
- 3 Cover
- 4 Sample
- 5 Base
- 6 Weight carrier

**Figure 11 — Compressibility tester**

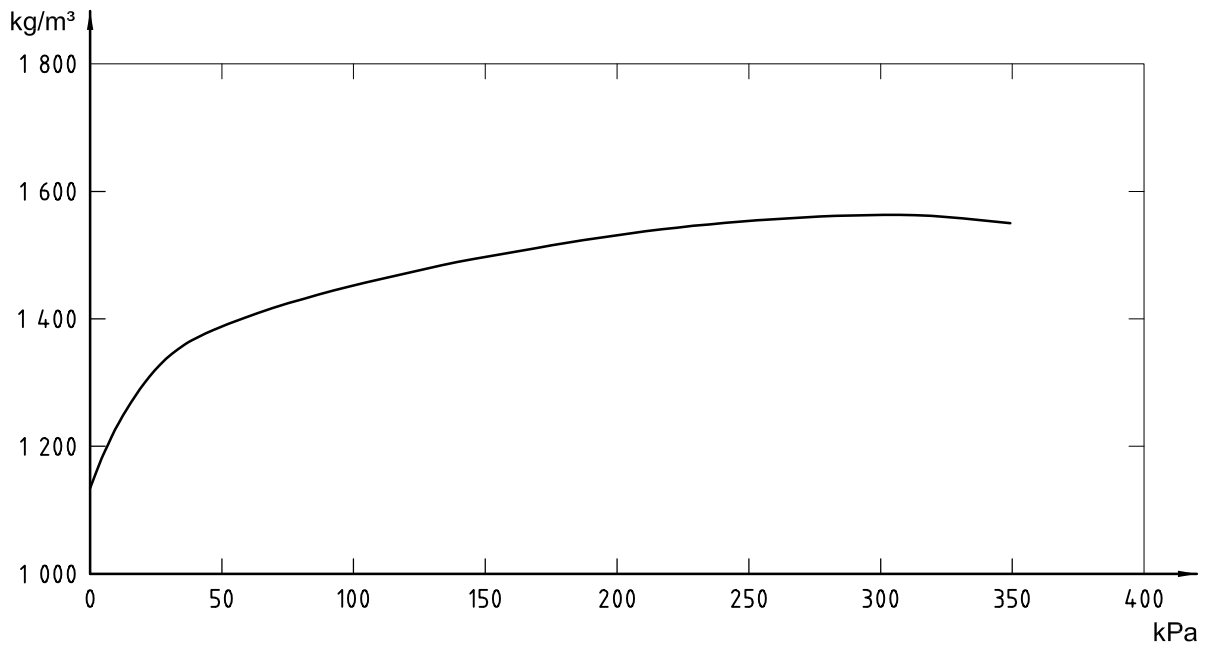

**Key**

kPa Major consolidating stress

kg/m<sup>3</sup> Bulk density

**Figure 12 — Typical bulk density curve**

## Annex A (informative)

### Bin design philosophy

#### A.1 General

The design of storage bins for bulk solids in general and coal in particular is a two-step process with respect to ensuring that material having measured properties will flow from the bin in the desired manner.

The first process is covered in this part of ISO 15117, i.e. the determination of the flow properties of the coal sample under the worst likely practical conditions.

The second process is the determination of bin geometry to give the desired capacity, to provide a desired flow pattern and to ensure that discharge from the bin is reliable and predictable. The following short summary indicates how the measurements made as described in this part of ISO 15117 may be applied to bin design.

#### A.2 Hopper half-angle ( $\alpha$ )

There are standard graphs relating wall friction ( $\phi$ ), hopper half-angle ( $\alpha$ ) and effective angle of internal friction ( $\delta$ ) for various shapes of hoppers, allowing for mass or funnel flow. Values of the effective angle of internal friction,  $\delta$  (see Figure 4 in Clause 6), and of wall friction,  $\phi$  (see 7.6), can be used to predict a hopper half-angle ( $\alpha$ ), to which a nominal factor of safety is added where appropriate.

#### A.3 Bin capacity

The hopper half-angle and material bulk density derived from Clause 8 can be used to determine the dimensions of the bin. Design modifications at this stage are possible by changing from mass to funnel flow or expanded flow, or changing the bin cross-section if there are dimensional limits.

#### A.4 Hopper outlet

Critical consolidation occurs when the major consolidation pressure, divided by the flow factor, is equal to the unconfined yield strength, i.e. the material is on the point of flowing. The minimum hopper opening is then a function of this strength and the bulk density of the coal, as described in Clauses 6 and 8. Flow factors for a converging channel as defined by Jenike are given in Reference [2] and other sources, such as Reference [1], where they are designated "ff".

#### A.5 References

The following references outline the relevant research techniques involved:

- [1] ARNOLD, P.C., MCLEAN, A.G. and ROBERTS, A.W. Bulk Solids: Storage, Flow and Handling TUNRA Bulk Solids Handling Research Associates, Second Edition 1980.
- [2] JENIKE, A.W. Storage and Flow of Solids Utah Engng Exper. St. Univ. of Utah, Bul. 123, 1964.
- [3] ROBERTS, A.W., ARNOLD, P.C., MCLEAN, A.G. and SCOTT, O.J. The Design of Gravity Storage Systems for Bulk Solids. Mech. Engng. Trans., IEAust., vol. ME7, No. 3, 1982, pp. 81-95.

- [4] ARNOLD, P.C., MCLEAN, A.G. and MOORE, B.A. The Application of Computer Graphics to the Flow Property Testing of Bulk Solids. Mech. Eng. Trans. IEAust., vol. ME7, No. 3, 1982, pp. 152-157.
- [5] MOORE, B.A., ARNOLD, P.C. and MCLEAN, A.G. Determination of Hopper Geometry Parameters using Interactive Computer Graphics. Bulk Solids Handling vol. 3, No.4, 1983, pp. 795-802.
- [6] MOORE, B.A. and ARNOLD, P.C. A Novel Method of Presenting Mass-Flow Hopper Geometry Parameters. Mech. Eng. Trans. IEAust., vol. ME9, No. 1, 1984, pp. 27-32.
- [7] MOORE, B.A. and ARNOLD, P.C. Alternative Design Charts for Determining the Critical Parameters for Mass-Flow Hoppers. Powder Technol. vol. 42, No. 1, 1985, pp. 79-89.



---

---

## BSI — British Standards Institution

BSI is the independent national body responsible for preparing British Standards. It presents the UK view on standards in Europe and at the international level. It is incorporated by Royal Charter.

### Revisions

British Standards are updated by amendment or revision. Users of British Standards should make sure that they possess the latest amendments or editions.

It is the constant aim of BSI to improve the quality of our products and services. We would be grateful if anyone finding an inaccuracy or ambiguity while using this British Standard would inform the Secretary of the technical committee responsible, the identity of which can be found on the inside front cover.  
Tel: +44 (0)20 8996 9000. Fax: +44 (0)20 8996 7400.

BSI offers members an individual updating service called PLUS which ensures that subscribers automatically receive the latest editions of standards.

### Buying standards

Orders for all BSI, international and foreign standards publications should be addressed to Customer Services. Tel: +44 (0)20 8996 9001.  
Fax: +44 (0)20 8996 7001. Email: [orders@bsi-global.com](mailto:orders@bsi-global.com). Standards are also available from the BSI website at <http://www.bsi-global.com>.

In response to orders for international standards, it is BSI policy to supply the BSI implementation of those that have been published as British Standards, unless otherwise requested.

### Information on standards

BSI provides a wide range of information on national, European and international standards through its Library and its Technical Help to Exporters Service. Various BSI electronic information services are also available which give details on all its products and services. Contact the Information Centre.  
Tel: +44 (0)20 8996 7111. Fax: +44 (0)20 8996 7048. Email: [info@bsi-global.com](mailto:info@bsi-global.com).

Subscribing members of BSI are kept up to date with standards developments and receive substantial discounts on the purchase price of standards. For details of these and other benefits contact Membership Administration.  
Tel: +44 (0)20 8996 7002. Fax: +44 (0)20 8996 7001.  
Email: [membership@bsi-global.com](mailto:membership@bsi-global.com).

Information regarding online access to British Standards via British Standards Online can be found at <http://www.bsi-global.com/bsonline>.

Further information about BSI is available on the BSI website at <http://www.bsi-global.com>.

### Copyright

Copyright subsists in all BSI publications. BSI also holds the copyright, in the UK, of the publications of the international standardization bodies. Except as permitted under the Copyright, Designs and Patents Act 1988 no extract may be reproduced, stored in a retrieval system or transmitted in any form or by any means – electronic, photocopying, recording or otherwise – without prior written permission from BSI.

This does not preclude the free use, in the course of implementing the standard, of necessary details such as symbols, and size, type or grade designations. If these details are to be used for any other purpose than implementation then the prior written permission of BSI must be obtained.

Details and advice can be obtained from the Copyright & Licensing Manager.  
Tel: +44 (0)20 8996 7070. Fax: +44 (0)20 8996 7553.  
Email: [copyright@bsi-global.com](mailto:copyright@bsi-global.com).