

BS ISO 15031-6:2015



BSI Standards Publication

# Road vehicles — Communication between vehicle and external equipment for emissions-related diagnostics

Part 6: Diagnostic trouble code definitions

**bsi.**

...making excellence a habit.™

**National foreword**

This British Standard is the UK implementation of ISO 15031-6:2015. It supersedes BS ISO 15031-6:2010 which is withdrawn.

The UK participation in its preparation was entrusted to Technical Committee AUE/16, Data Communication (Road Vehicles).

A list of organizations represented on this committee can be obtained on request to its secretary.

This publication does not purport to include all the necessary provisions of a contract. Users are responsible for its correct application.

© The British Standards Institution 2015. Published by BSI Standards Limited 2015

ISBN 978 0 580 86692 0

ICS 13.040.50; 43.040.10

**Compliance with a British Standard cannot confer immunity from legal obligations.**

This British Standard was published under the authority of the Standards Policy and Strategy Committee on 31 August 2015.

**Amendments issued since publication**

Date	Text affected
------	---------------

---

---

---

**Road vehicles — Communication  
between vehicle and external  
equipment for emissions-related  
diagnostics —**

Part 6:  
**Diagnostic trouble code definitions**

*Véhicules routiers — Communications entre un véhicule et un  
équipement externe concernant le diagnostic relatif aux émissions —  
Partie 6: Définition des codes d'anomalie de diagnostic*





**COPYRIGHT PROTECTED DOCUMENT**

© ISO 2015, Published in Switzerland

All rights reserved. Unless otherwise specified, no part of this publication may be reproduced or utilized otherwise in any form or by any means, electronic or mechanical, including photocopying, or posting on the internet or an intranet, without prior written permission. Permission can be requested from either ISO at the address below or ISO's member body in the country of the requester.

ISO copyright office  
Ch. de Blandonnet 8 • CP 401  
CH-1214 Vernier, Geneva, Switzerland  
Tel. +41 22 749 01 11  
Fax +41 22 749 09 47  
copyright@iso.org  
www.iso.org

# Contents

Page

<b>Foreword</b> .....	<b>iv</b>
<b>Introduction</b> .....	<b>v</b>
<b>1 Scope</b> .....	<b>1</b>
<b>2 Normative references</b> .....	<b>1</b>
<b>3 Terms, definitions, symbols, and abbreviated terms</b> .....	<b>2</b>
3.1 Terms and definitions.....	2
3.2 Abbreviated terms.....	2
<b>4 Conventions</b> .....	<b>2</b>
<b>5 Document overview</b> .....	<b>2</b>
<b>6 General specification</b> .....	<b>4</b>
6.1 General code information.....	4
6.2 Sensor location definition.....	4
6.2.1 General.....	4
6.2.2 Definition of V6/V8/V12 cylinder engine with two exhaust banks and four catalyts.....	5
6.2.3 Definition of V6/V8/V12 cylinder engine with two exhaust banks and three catalyts.....	5
6.2.4 Definition of L4/L5/L6 cylinder engine with one exhaust bank and two catalyts.....	6
6.2.5 Definition of L4/L5/L6 cylinder engine with one exhaust bank and one catalyts.....	6
6.2.6 Definition of turbocharger/supercharger pressure sensor location draw- thru system.....	6
<b>7 Format structure</b> .....	<b>7</b>
7.1 Description.....	7
7.2 ISO/SAE controlled codes (core DTCs).....	9
7.3 Manufacturer controlled codes (non-uniform DTCs).....	9
7.4 Body system groupings.....	10
7.5 Chassis system groupings.....	10
7.6 Powertrain system groupings.....	10
7.7 Network and vehicle integration groupings.....	10
<b>8 Diagnostic trouble code descriptions</b> .....	<b>11</b>
8.1 Diagnostic trouble code application.....	11
8.2 Powertrain systems.....	11
8.3 Body systems.....	12
8.4 Chassis systems.....	12
8.5 Network and vehicle integration systems.....	12
<b>Annex A (normative) Diagnostic trouble code naming guidelines</b> .....	<b>13</b>
<b>Bibliography</b> .....	<b>16</b>

## Foreword

ISO (the International Organization for Standardization) is a worldwide federation of national standards bodies (ISO member bodies). The work of preparing International Standards is normally carried out through ISO technical committees. Each member body interested in a subject for which a technical committee has been established has the right to be represented on that committee. International organizations, governmental and non-governmental, in liaison with ISO, also take part in the work. ISO collaborates closely with the International Electrotechnical Commission (IEC) on all matters of electrotechnical standardization.

The procedures used to develop this document and those intended for its further maintenance are described in the ISO/IEC Directives, Part 1. In particular the different approval criteria needed for the different types of ISO documents should be noted. This document was drafted in accordance with the editorial rules of the ISO/IEC Directives, Part 2 (see [www.iso.org/directives](http://www.iso.org/directives)).

Attention is drawn to the possibility that some of the elements of this document may be the subject of patent rights. ISO shall not be held responsible for identifying any or all such patent rights. Details of any patent rights identified during the development of the document will be in the Introduction and/or on the ISO list of patent declarations received (see [www.iso.org/patents](http://www.iso.org/patents)).

Any trade name used in this document is information given for the convenience of users and does not constitute an endorsement.

For an explanation on the meaning of ISO specific terms and expressions related to conformity assessment, as well as information about ISO's adherence to the WTO principles in the Technical Barriers to Trade (TBT) see the following URL: [Foreword - Supplementary information](#)

The committee responsible for this document is ISO/TC 22, *Road vehicles*, Subcommittee SC 31, *Data communication*.

This third edition cancels and replaces the second edition (ISO 15031-6:2010), which has been technically revised.

ISO 15031 consists of the following parts, under the general title *Road vehicles — Communication between vehicle and external equipment for emissions-related diagnostics*:

- *Part 1: General information and use case definition*
- *Part 2: Guidance on terms, definitions, abbreviations and acronyms*
- *Part 3: Diagnostic connector and related electrical circuits, specification and use*
- *Part 4: External test equipment*
- *Part 5: Emissions-related diagnostic services*
- *Part 6: Diagnostic trouble code definitions*
- *Part 7: Data link security*

# Introduction

## Overview

ISO 15031 consists of a number of parts which, taken together, provide a coherent self-consistent set of specifications to facilitate emissions-related diagnostics. ISO 15031-1 provides an introduction to the series of International Standards. ISO 15031-2 through ISO 15031-7 are based on SAE recommended practices. This part of ISO 15031 is based on SAE J2012 (Diagnostic Trouble Code Definitions).

This International Standard includes the communication between the vehicle's On-Board Diagnostic (OBD) systems and test equipment implemented across vehicles within the scope of the legislated emissions-related OBD.

To achieve this, it is based on the Open Systems Interconnection (OSI) Basic Reference Model in accordance with ISO/IEC 7498 and ISO/IEC 10731, which structures communication systems into seven layers. When mapped on this model, the services specified by this International Standard are broken into the following layers in accordance with [Table 1](#).

- Diagnostic services (layer 7), specified in the following:
  - ISO 15031-5 (emissions-related OBD);
  - ISO 27145-3 (WWH-OBD).
- Presentation layer (layer 6), specified in the following:
  - ISO 15031-2, SAE J1930-DA;
  - ISO 15031-5, SAE J1979-DA;
  - ISO 15031-6, SAE J2012-DA (OBD);
  - ISO 27145-2, SAE J2012-DA (WWH-OBD).
- Session layer services (layer 5), specified in the following:
  - ISO 14229-2 supports ISO 15765-4 DoCAN and ISO 14230-4 DoK-Line protocols;
  - ISO 14229-2 is not applicable to the SAE J1850 and ISO 9141-2 protocols.
- Transport layer services (layer 4), specified in the following:
  - ISO 15765-2 Transport protocol and network layer services;
  - SAE J1850 defined in ISO 15031-5 Emissions-related diagnostic services;
  - ISO 9141-2 defined in ISO 15031-5 Emissions-related diagnostic services;
  - ISO 14230-4 defined in ISO 15031-5 Emissions-related diagnostic services.
- Network layer services (layer 3), specified in the following:
  - ISO 15765-2 Transport protocol and network layer services;
  - SAE J1850 defined in ISO 15031-5 Emissions-related diagnostic services;
  - ISO 9141-2 defined in ISO 15031-5 Emissions-related diagnostic services;
  - ISO 14230-4 defined in ISO 15031-5 Emissions-related diagnostic services.
- Data link layer (layer 2), specified in the following:
  - ISO 15765-4, ISO 11898-1, ISO 11898-2;

- SAE J1850;
- ISO 9141-2;
- ISO 14230-2.
- Physical layer (layer 1), specified in the following:
  - ISO 15765-4, ISO 11898-1, ISO 11898-2;
  - SAE J1850;
  - ISO 9141-2;
  - ISO 14230-1.

**Table 1 — Legislated emissions-related OBD/WWH-OBD diagnostic specifications applicable to the OSI layers**

Applicability	OSI 7 layers	Emissions-related OBD communication requirements				Emissions-related WWH-OBD communication requirements			
Seven layer according to ISO/IEC 7498-1 and ISO/IEC 10731	Application (layer 7)	ISO 15031-5				ISO 27145-3			
	Presentation (layer 6)	ISO 15031-2, -5, -6 SAE J1930-DA/SAE J1979-DA				ISO 27145-2 SAE J1930-DA/SAE J1979-DA			
		SAE J2012-DA (OBD)				SAE J2012-DA (WWH-OBD)			
	Session (layer 5)	Not applicable		ISO 14229-2					
	Transport (layer 4)	ISO 15031-5		ISO 14230-4	ISO 15765-2	ISO 15765-4	ISO 15765-2	ISO 27145-4	ISO 13400-2
	Network (layer 3)			ISO 14230-2	ISO 11898-1, ISO 11898-2		ISO 11898-1, ISO 11898-2		ISO 13400-3
	Data link (layer 2)	SAE J1850	ISO 9141-2	ISO 14230-1	ISO 11898-1, ISO 11898-2	ISO 15765-4	ISO 11898-1, ISO 11898-2	ISO 27145-4	ISO 13400-3
	Physical (layer 1)	SAE J1850	ISO 9141-2	ISO 14230-1	ISO 11898-1, ISO 11898-2	ISO 15765-4	ISO 11898-1, ISO 11898-2	ISO 27145-4	ISO 13400-3

**SAE document reference concept**

ISO 15031 references several SAE documents which contain all terms, data, and DTC definitions.

See [Figure 1](#) with the following definition of content in this International Standard.

- SAE J1930: the document is concerned with a procedure for naming objects and systems and with the set of words from which names are built. It references SAE J1930-DA which contains all standardized naming objects, terms, and abbreviations.
- SAE J1979: the document is concerned with the definition of emissions-related diagnostic services (diagnostic test modes). It references SAE J1979-DA which contains all standardized data items like PIDs, test IDs, monitor IDs, and InfoType IDs.
- SAE J2012: the document is concerned with the procedure for defining emissions-related diagnostic trouble codes. It references SAE J2012-DA which contains all standardized data items like DTCs and FTBs.



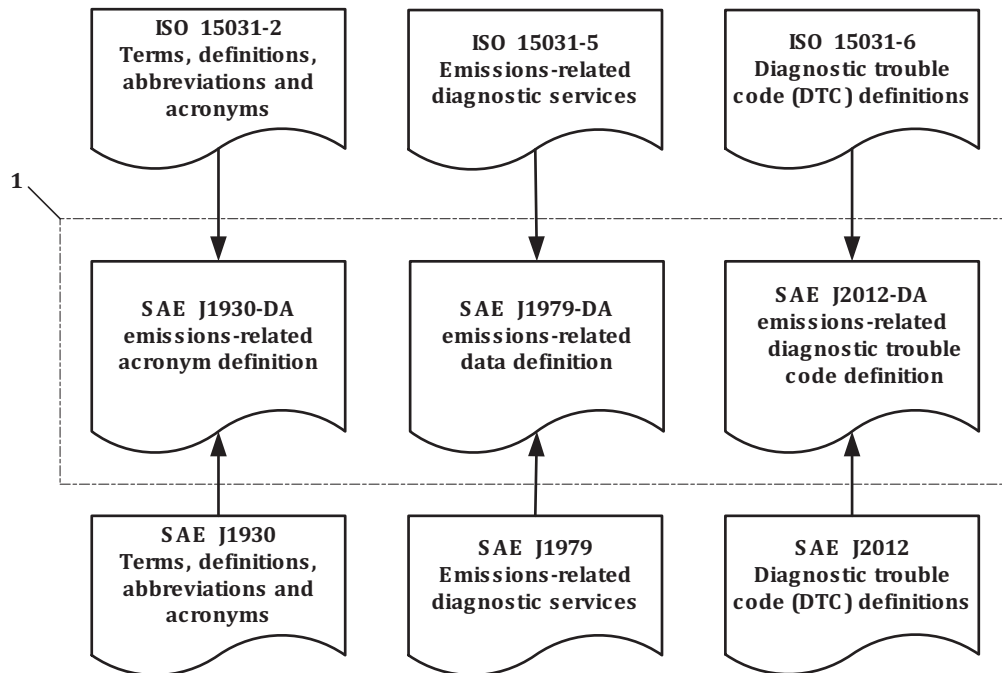

**Key**

1 SAE Digital Annexes

**Figure 1 — SAE Digital Annex document reference**

On-Board Diagnostic (OBD) regulations require passenger cars and light, medium, and heavy duty trucks to support a minimum set of diagnostic information to external (off-board) “generic” test equipment. New emissions-related regulatory requirements drive new in-vehicle technology to lower emissions. New technology-related OBD monitor data and diagnostic trouble codes need to be standardized to support the external (off-board) “generic” test equipment. All relevant information is proposed by the automotive industry represented by members of the appropriate SAE task force.

**SAE J2012-DA (OBD) Digital Annex**

This part of ISO 15031 references SAE J2012-DA. SAE J2012-DA is concerned with the definition of DTCs (diagnostic trouble codes) and FTB (failure type byte) information.

SAE J2012-DA (OBD) includes several appendices for

- diagnostic trouble code naming guidelines,
- powertrain system diagnostic trouble codes,
- network communication system, body systems, chassis systems, and
- DTC failure category and subtype definition.

**SAE Digital Annex revision procedure**

New emissions-related regulatory requirements drive new in-vehicle technology to lower emissions. New technology-related OBD monitor data and diagnostic trouble codes need to be standardized to support the external (off-board) “generic” test equipment. All relevant information is proposed by the automotive industry represented by members of the appropriate SAE task force.

Revision request forms and instructions for updating the registers to this part of ISO 15031 can be obtained on the Registration Authority’s website at:

<http://www.sae.org/servlets/works/committeeHome.do?comtID=TEVDS9>

The column titled “Resources” shows a document with the title: J2012-DA\_Revision\_Request\_Form.doc. Double click on the name and you will be asked to download the document with the filename:

SAE J2012-DA\_Revision\_Request\_Form.doc

Fill out the revision request form with your request.

Please send e-mail with completed revision request form as attachment to:

SAE Headquarters  
755 West Big Beaver Road  
Suite 1600  
Troy, MI 48084-4093, USA  
Fax: +1 (248) 273-2494  
Email: saej2012@sae.org

# Road vehicles — Communication between vehicle and external equipment for emissions-related diagnostics —

## Part 6: Diagnostic trouble code definitions

### 1 Scope

This part of ISO 15031 provides uniformity for standardized diagnostic trouble codes (DTC) that electrical/electronic On-Board Diagnostic (OBD) systems of motor vehicles are required to report when malfunctions are detected. It further provides guidance for uniform messages (text descriptor) associated with these codes.

This part of ISO 15031 specifies the rules and guidelines for the definition of the following:

- a) the diagnostic trouble code format, which consists of the following:
  - 1) addressing format;
  - 2) structure;
  - 3) messages;
- b) a description of the standardized set of diagnostic trouble codes and descriptions contained in SAE J2012-DA. The two most significant bytes of a DTC may be decoded according to two different lists in two formats: DTC Format Identifier 00<sub>16</sub> and 04<sub>16</sub>;
- c) a description of the standardized set of diagnostic trouble codes subtypes known as failure types contained in SAE J2012-DA (applies only when 3-byte DTCs are used).

This part of ISO 15031 specifies all general rules and guidelines to define new diagnostic trouble codes. This part of ISO 15031 references SAE J2012-DA (Digital Annex), which includes all standardized DTCs (number and text descriptor) as well as all diagnostic trouble codes subtypes known as failure types.

### 2 Normative references

The following documents, in whole or in part, are normatively referenced in this document and are indispensable for its application. For dated references, only the edition cited applies. For undated references, the latest edition of the referenced document (including any amendments) applies.

ISO/IEC 10731:1994, *Information technology — Open Systems Interconnection — Basic Reference Model — Conventions for the definition of OSI services*

ISO 15031-2, *Road vehicles — Communication between vehicle and external equipment for emissions-related diagnostics — Part 2: Guidance on terms, definitions, abbreviations and acronyms*

ISO 15031-5, *Road vehicles — Communication between vehicle and external equipment for emissions-related diagnostics — Part 5: Emissions-related diagnostic services*

### 3 Terms, definitions, symbols, and abbreviated terms

#### 3.1 Terms and definitions

For the purposes of this document, the terms and definitions given in ISO 15031-2 apply.

#### 3.2 Abbreviated terms

B1S1	Bank 1 Sensor 1
B1S2	Bank 1 Sensor 2
B1S3	Bank 1 Sensor 3
B2S1	Bank 2 Sensor 1
B2S2	Bank 2 Sensor 2
B2S3	Bank 2 Sensor 3
BARO	barometric atmospheric pressure
CVN	calibration verification number
DTC	diagnostic trouble code
ECM	engine control module
ISR	interrupt service routine
LSB	least significant bit
MAF	mass air flow
MAP	manifold absolute pressure
MIL	malfunction indicator light
MSB	most significant bit
OBD	On-Board Diagnostics
OSI	Open Systems Interconnection
PCM	powertrain control module
SI	international system of units
TCM	transmission control module

### 4 Conventions

ISO 15031 is based on the conventions discussed in the OSI Service Conventions (ISO/IEC 10731) as they apply for diagnostic services.

### 5 Document overview

[Figure 2](#) illustrates the document references.

The protocol initialization identifies whether ISO 15765-4 DoCAN or SAE J1850 or ISO 14230-4 DoK-Line or ISO 9141-2 is the data link layer supported by the vehicle. ISO 15031 references the standards as an applicable data link for emissions-related OBD.

ISO 15031-5 specifies the applicable emissions-related diagnostic services. This part of ISO 15031 specifies the data record structures and references SAE J1930-DA, SAE J1979-DA, and SAE J2012-DA which include all emissions-related OBD data definitions.

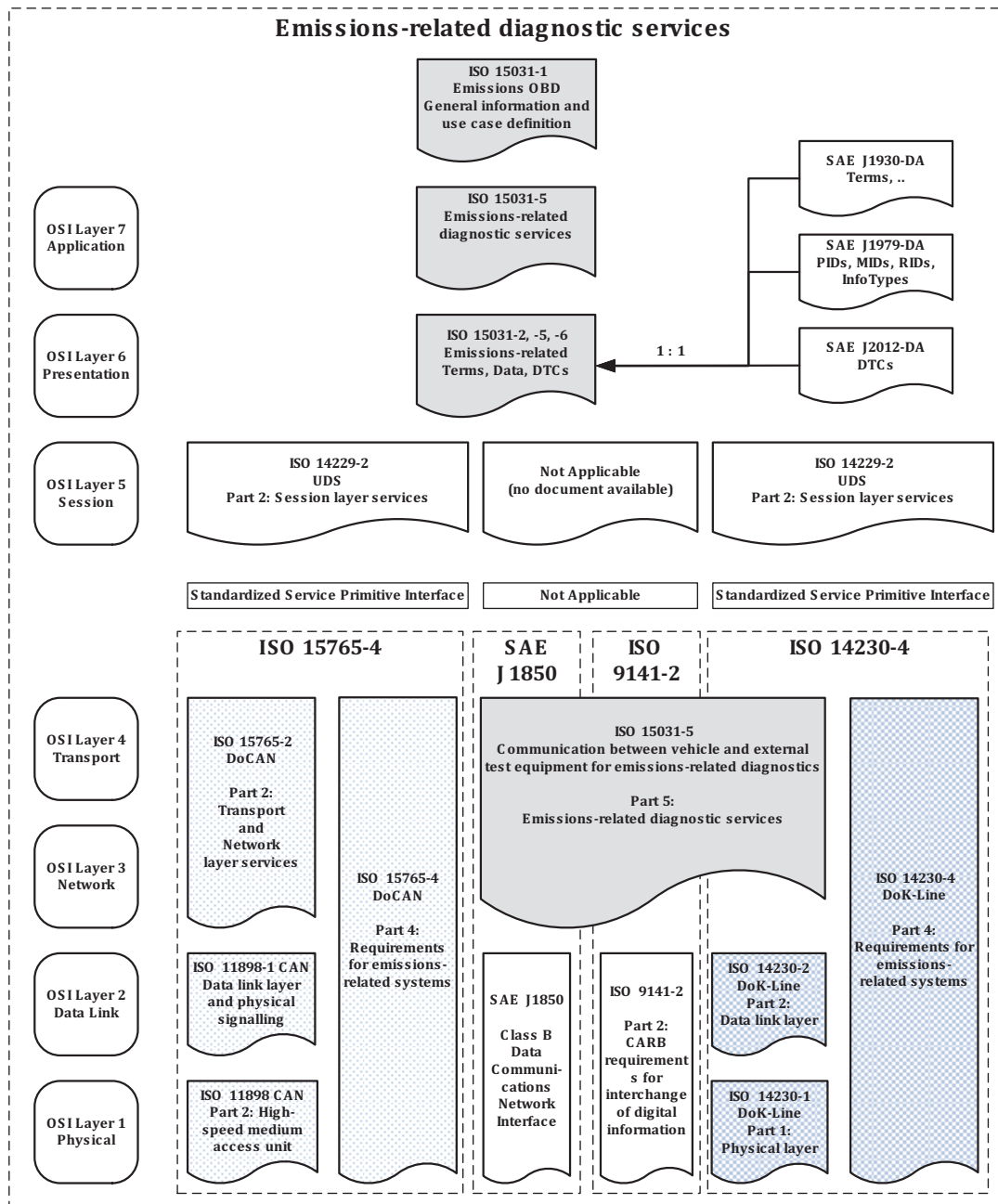

Figure 2 — Emissions-related OBD on ISO 15765-4, SAE J1850, ISO 9141-2, ISO 14230-4 document reference according to OSI model

## 6 General specification

### 6.1 General code information

[Table 2](#) specifies systems, code categories, hexadecimal values, and particular sections of electrical/electronic systems diagnostic.

**Table 2 — General code specifications**

System	Code categories	Hex value	Appendix
Body	B0xxx – B3xxx	8XXX <sub>16</sub> – BXXX <sub>16</sub>	B
Chassis	C0xxx – C3xxx	4XXX <sub>16</sub> – 7xxx <sub>16</sub>	C
Powertrain	P0xxx – P3xxx	0XXX <sub>16</sub> – 3XXX <sub>16</sub>	P
Generic/Network and vehicle integration	U0xxx – U3xxx	CXXX <sub>16</sub> – FXXX <sub>16</sub>	U

The recommended DTCs consist of a three digit hexadecimal code preceded by an alphanumeric designator. The alphanumeric designators are “B0”, “B1”, “B2”, “B3”, “C0”, “C1”, “C2”, “C3”, “P0”, “P1”, “P2”, “P3”, “U0”, “U1”, “U2”, “U3”, corresponding to four sets of body, four sets of chassis, four sets of powertrain, and four sets of network and vehicle integration trouble codes. The code structure itself is partially open-ended. A portion of the available numeric sequences (portions of “B0”, “C0”, “P0”, “P2”, “P3”, “U0”, and “U3”) is reserved for uniform codes assigned by this or future updates. Detailed specifications of the DTC format structure are specified in [Clause 7](#). Most circuit, component, or system diagnostic trouble codes that do not support a subfault strategy are specified by the following four basic categories:

- circuit/open;
- range/performance;
- circuit low;
- circuit high.

Circuit low is measured with the external circuit, component, or system connected. The signal type (voltage, frequency, etc.) shall be included in the message after circuit low or circuit high.

Circuit high is measured with the external circuit, component, or system connected. The signal type (voltage, frequency, etc.) may be included in the message after circuit low or circuit high.

### 6.2 Sensor location definition

#### 6.2.1 General

This subclause defines the location of sensor(s) in relation to the engine air flow, starting from the fresh air intake through to the vehicle tail pipe or fuel flow from the fuel tank to the engine in order numbering 1, 2, 3, and so on.

NOTE 1 If there is only one bank, use bank #1 DTCs and the word bank may be omitted. With a single “bank” system using multiple sensors, use bank #1.

NOTE 2 See [Figure 3](#) to [Figure 7](#).

### 6.2.2 Definition of V6/V8/V12 cylinder engine with two exhaust banks and four catalyts

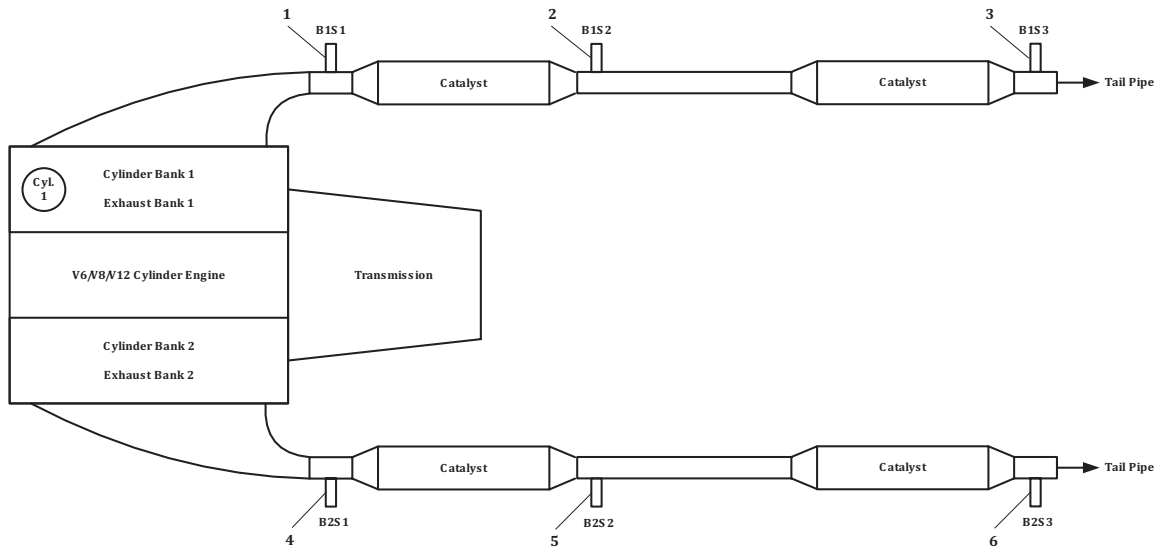

#### Key

- 1 B1S1 – Bank 1 Sensor 1 wide range
- 2 B1S2 – Bank 1 Sensor 2 heated
- 3 B1S3 – Bank 1 Sensor 3 heated
- 4 B2S1 – Bank 2 Sensor 1 wide range
- 5 B2S2 – Bank 2 Sensor 2 heated
- 6 B2S3 – Bank 2 Sensor 3 heated

Figure 3 — V6/V8/V12 cylinder engine with two exhaust banks and four catalyts example

### 6.2.3 Definition of V6/V8/V12 cylinder engine with two exhaust banks and three catalyts

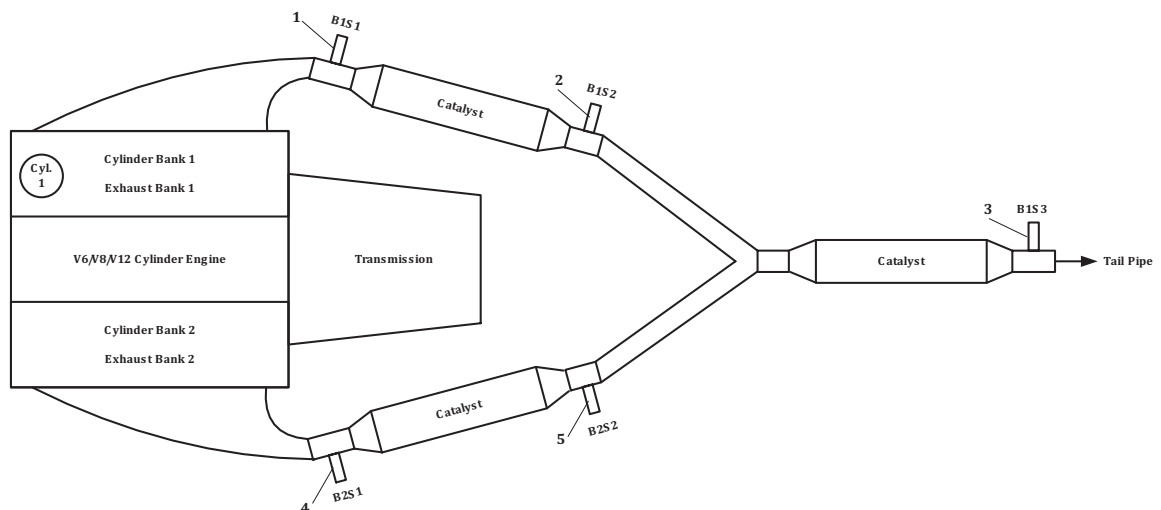

#### Key

- 1 B1S1 – Bank 1 Sensor 1 wide range
- 2 B1S2 – Bank 1 Sensor 2 heated
- 3 B1S3 – Bank 1 Sensor 3 heated
- 4 B2S1 – Bank 2 Sensor 1 wide range

Figure 4 — V6/V8/V12 cylinder engine with two exhaust banks and three catalyts example

### 6.2.4 Definition of L4/L5/L6 cylinder engine with one exhaust bank and two catalyts

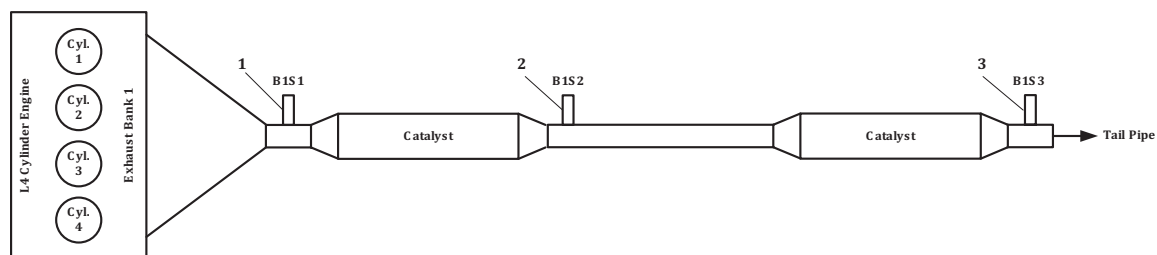

#### Key

- 1 B1S1 – Bank 1 Sensor 1 wide range
- 2 B1S2 – Bank 1 Sensor 2 heated
- 3 B1S3 – Bank 1 Sensor 3 heated

Figure 5 — L4/L5/L6 cylinder engine with one exhaust bank and two catalyts example

### 6.2.5 Definition of L4/L5/L6 cylinder engine with one exhaust bank and one catalyts

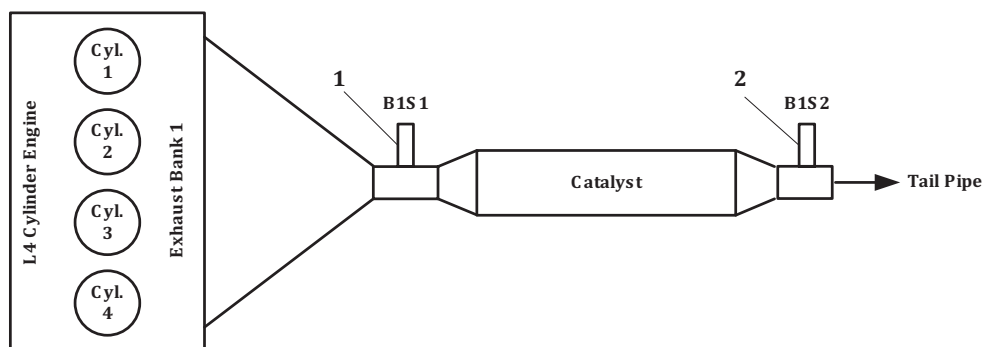

#### Key

- 1 B1S1 – Bank 1 Sensor 1 wide range
- 2 B1S2 – Bank 1 Sensor 2 heated

Figure 6 — L4/L5/L6 cylinder engine with one exhaust bank and one catalyts example

### 6.2.6 Definition of turbocharger/supercharger pressure sensor location draw-thru system

The intake air system pressure sensor location for boosted applications in relation to the engine air flow includes the fresh air inlet, boost device, and engine manifold.



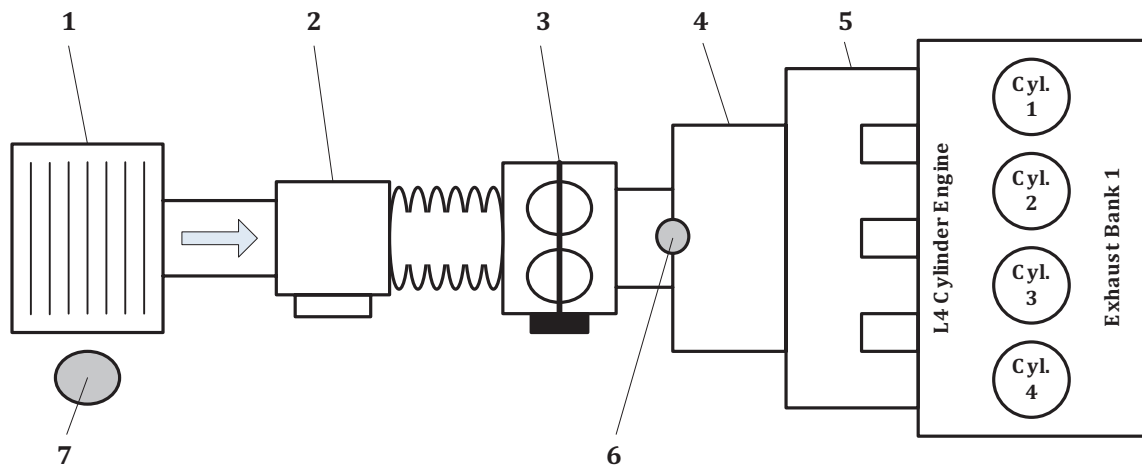

**Key**

- 1 air cleaner
- 2 MAF
- 3 throttle body
- 4 turbocharger/supercharger
- 5 MAP (manifold pressure closest to the intake valves)
- 6 inlet (pressure after the throttle body, but before the pressurizing device)
- 7 BARO (atmospheric pressure)

**Figure 7 — Turbocharger/supercharger pressure sensor location draw-thru system**

## 7 Format structure

### 7.1 Description

[Figure 8](#) illustrates the diagnostic trouble code which consists of an alphanumeric designator, B0 – B3 for body, C0 – C3 for chassis, P0 – P3 for powertrain, and U0 – U3 for network communication, followed by three characters. The assignment of the proper alpha designator should be determined by the area most appropriate for that function. In most cases, the alpha designator will be implied since diagnostic information will be requested from a particular controller. However, this does not imply that all codes supported by a particular controller shall have the same alphanumeric designator.

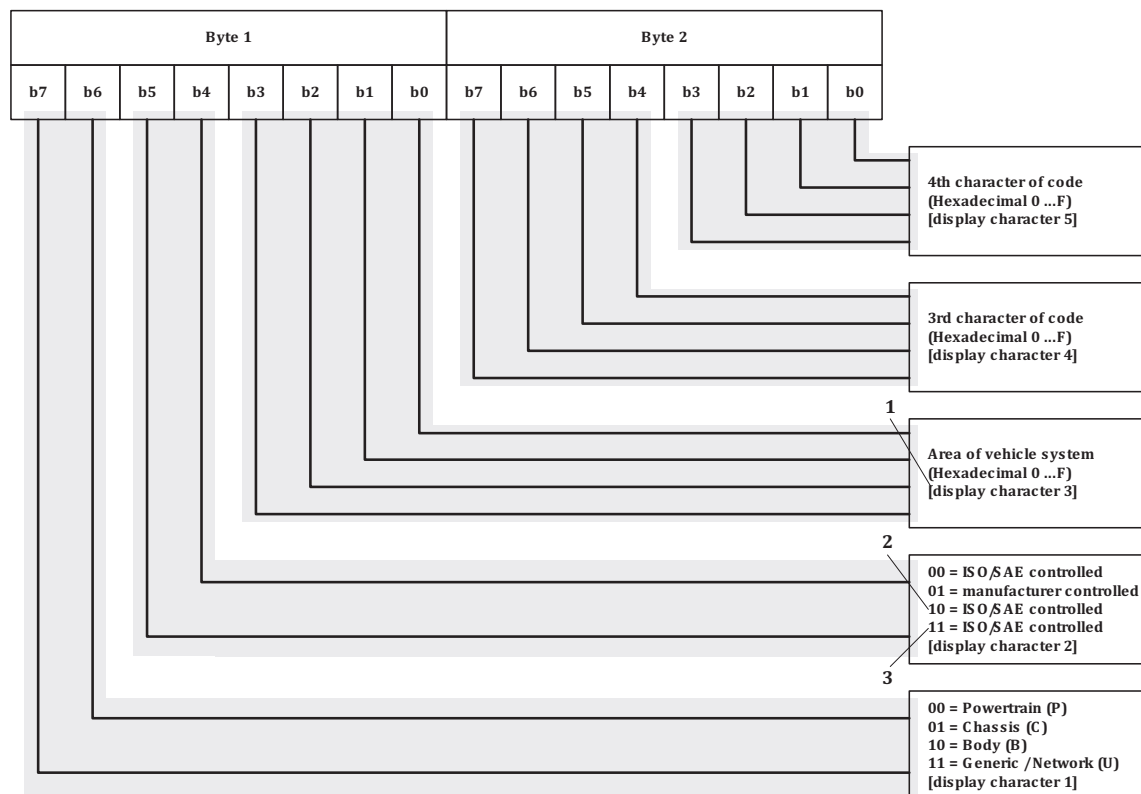

- Key**
- display character 3 is used to identify a specific vehicle area; within any area, display characters 4 and 5 allow up to 256 code definitions
  - for powertrain, these bits are ISO/SAE controlled; for all others, they are manufacturer controlled
  - for powertrain, 11 = manufacturer controlled for P3000 to P33FF; 11 = ISO/SAE reserved for P3400 to P3FFF

**Figure 8 — Structure of diagnostic trouble codes**

DTCs decoding according to this part of ISO 15031 may be either 2 bytes in length (e.g. SAE J1979) or 3 bytes in length (e.g. ISO 14229-1).

When 2-byte DTCs are used in accordance with this specification, they are always decoded according to a single list as contained within SAE J2012-DA.

When 3-byte DTCs are used in accordance with this specification, the two most significant bytes are decoded based upon the DTC Format Identifier (00<sub>16</sub> or 04<sub>16</sub>) specified by the implemented diagnostic protocol; the least significant byte is decoded based upon SAE J2012-DA failure type byte (FTB) table.

**EXAMPLE** A 2-byte DTC as a data bus value 9234<sub>16</sub> would be displayed to technicians as the manufacturer controlled body code B1234. See [Figure 9](#).

[Figure 9](#) shows the example of the 2-byte DTC structure.

DTC High Byte								DTC Low Byte											
0x9				0x2				0x3				0x4							
1	0	0	1	0	0	1	0	0	0	1	1	0	1	0	0				
B				1				2				3				4			

**Figure 9 — Example of the 2-byte DTC structure**

[Figure 10](#) shows the example of 3-byte DTC Format Identifier 00<sub>16</sub> DTC structure.

A 3-byte DTC using DTC Format Identifier 00<sub>16</sub> as a data bus value 923411<sub>16</sub> would be displayed to technicians as the manufacturer controlled body code B1234-11; see [Figure 8](#). See SAE J2012-DA FTB tables for DTC low byte (failure type byte) definitions. The low byte shall be displayed in hexadecimal format, e.g. 11<sub>16</sub> shall be displayed as “11”. When the most significant 2 bytes of this DTC is contained within the SAE controlled range, it is decoded according to the DTC Format Identifier 00<sub>16</sub> list from SAE J2012-DA. See [Figure 10](#).

DTC High Byte				DTC Middle Byte				DTC Low Byte			
0x9		0x2		0x3		0x4		0x1		0x1	
1	0	0	1	0	0	1	1	0	1	0	0
B		1			3		4		1		1

**Figure 10 — Example of 3-byte DTC Format Identifier 00<sub>16</sub> DTC structure**

[Figure 11](#) shows the example of 3-byte DTC Format Identifier 04<sub>16</sub> DTC structure.

A 3-byte DTC using DTC Format Identifier 04<sub>16</sub> as a data bus value 923411<sub>16</sub> would be displayed to technicians as the manufacturer controlled body code B1234-11; see [Figure 8](#). See SAE J2012-DA FTB tables for DTC low byte (failure type byte) definitions. The low byte shall be displayed in hexadecimal format, e.g. 11<sub>16</sub> shall be displayed as “11”. When the most significant 2 bytes of this DTC is contained within the SAE controlled range, it is decoded according to the DTC Format Identifier 04<sub>16</sub> list from SAE J2012-DA.

DTC High Byte				DTC Middle Byte				DTC Low Byte			
0x9		0x2		0x3		0x4		0x1		0x1	
1	0	0	1	0	0	1	1	0	1	0	0
B		1			3		4		1		1

**Figure 11 — Example of 3-byte DTC Format Identifier 04<sub>16</sub> DTC structure**

Codes have been specified to indicate a suspected trouble or problem area and are intended to be used as a directive to the proper service procedure. To minimize service confusion, fault codes should not be used to indicate the absence of problems or the status of parts of the system (e.g. powertrain system O.K. or MIL activated) but should be confined to indicate areas in need of service attention.

Standard DTC ranges contained in SAE J2012-DA have 256 DTC possibilities by using the hexadecimal 16 base number system.

## 7.2 ISO/SAE controlled codes (core DTCs)

ISO/SAE controlled diagnostic trouble codes are those codes where industry uniformity has been achieved. These codes were felt to be common enough across most manufacturers’ applications that a common number and fault message could be assigned. All unspecified numbers in each grouping are ISO/SAE reserved for future growth. Although service procedures may differ widely amongst manufacturers, the fault being indicated is common enough to be assigned a particular fault code. Codes in this area are not to be used by manufacturers until they have been approved by ISO/SAE.

## 7.3 Manufacturer controlled codes (non-uniform DTCs)

Areas within each alpha designator have been made available for manufacturer-controlled DTCs. These are fault codes that will not generally be used by a majority of the manufacturers due to basic system differences, implementation differences, or diagnostic strategy differences. Each vehicle manufacturer or supplier who designs and specifies diagnostic algorithms, software, and diagnostic trouble codes are strongly encouraged to remain consistent across their product line when assigning codes in the manufacturer controlled area. It is recommended for powertrain codes to use the same groupings as in the ISO/SAE controlled area, i.e. 100’s and 200’s for fuel and air metering, 300’s for ignition system or misfire, etc.

While each manufacturer has the ability to define the controlled DTCs to meet their specific controller algorithms, all DTC descriptions shall meet ISO 15031-2 and SAE J1930-DA.

#### 7.4 Body system groupings

DTC numbers and descriptions are given in SAE J2012-DA.

[Table 3](#) defines the body system groupings.

**Table 3 — Body system groupings**

DTC range	Description
B0000 – B0FFF	ISO/SAE controlled
B1000 – B1FFF	manufacturer controlled
B2000 – B2FFF	manufacturer controlled
B3000 – B3FFF	reserved by document

#### 7.5 Chassis system groupings

DTC numbers and descriptions are given in SAE J2012-DA.

[Table 4](#) defines the chassis system groupings.

**Table 4 — Chassis system groupings**

DTC range	Description
C0000 – C0FFF	ISO/SAE controlled
C1000 – C1FFF	manufacturer controlled
C2000 – C2FFF	manufacturer controlled
C3000 – C3FFF	reserved by document

#### 7.6 Powertrain system groupings

DTC numbers and descriptions are given in SAE J2012-DA.

[Table 5](#) defines the powertrain system groupings.

**Table 5 — Powertrain system groupings**

DTC range	Description
P0000 – P0FFF	ISO/SAE controlled
P1000 – P1FFF	manufacturer controlled
P2000 – P2FFF	ISO/SAE controlled
P3000 – P33FF	manufacturer controlled
P3400 – P3FFF	ISO/SAE controlled

#### 7.7 Network and vehicle integration groupings

DTC numbers and descriptions are given in SAE J2012-DA.

[Table 6](#) defines the network and vehicle integration groupings.

**Table 6 — Network and vehicle integration groupings**

DTC range	Description
U0000 – U0FFF	ISO/SAE controlled
U1000 – U1FFF	manufacturer controlled
U2000 – U2FFF	manufacturer controlled
U3000 – U3FFF	ISO/SAE controlled

## 8 Diagnostic trouble code descriptions

### 8.1 Diagnostic trouble code application

The SAE J2012-DA scope includes DTCs and descriptions for powertrain systems, network and vehicle integration systems, body systems, and chassis systems. Three different DTC application methods are possible. This specification does not specify which DTC structure is used, rather it describes how to decode the DTC based upon which structure is used. Traditionally, powertrain DTCs were 2 bytes in length and therefore required the assignment of a unique DTC number and description for each failure mode (e.g. circuit low, circuit high, rationality, etc.) using only the 2-byte DTC structure. More recent diagnostic protocols, including those for enhanced diagnostics, use 3-byte DTCs that are decoded according to SAE J2012 and SAE J2012-DA. Some legislated protocols, such as ISO 27145, allow the reporting of 3-byte DTCs as well. When 3-byte DTCs are used in accordance with this specification, the two most significant bytes are decoded based upon the DTC Format Identifier (00<sub>16</sub> or 04<sub>16</sub>) required by the implemented diagnostic protocol; the least significant byte can describe the exact nature of a fault and shall be decoded based upon SAE J2012-DA failure type byte (FTB) table. In order to support a migration from 2-byte DTCs to 3-byte DTCs and allow reclaiming of the 2-byte base DTCs, the P-code and U-code list has two distinct decoding options for 3-byte DTCs based on whether DTC Format Identifier 00<sub>16</sub> or 04<sub>16</sub> is used. For this reason, diagnostic protocols returning 3-byte DTCs decoding per SAE J2012 shall clearly specify which DTC Format Identifier is used. SAE J2012-DA has been updated to show sample conversions from a 2-byte DTC with an embedded failure mode to the 3-byte DTC list using DTC Format Identifier 04<sub>16</sub>. This mapping provided for the failure type byte when converting from 2-byte DTCs to 3-byte DTCs using DTC Format Identifier 04<sub>16</sub> is only one possibility. Manufacturers using 3-byte DTCs based upon SAE J2012 are responsible to select the most appropriate failure type byte from SAE J2012-DA to apply to the base 2-byte DTC description.

All body and chassis systems base DTC descriptions in SAE J2012-DA are more general (i.e. failure mode is not embedded) and therefore have been allocated only to be used with the 3-byte DTC structures. Due to the usage of the failure type byte as the third (least significant) byte, these DTCs require only the assignment of a single DTC number and description for each component, not failure mode.

### 8.2 Powertrain systems

The powertrain systems category covers functions that include engine, transmission, and associated drivetrain accessories. For powertrain systems, each specified fault code has been assigned a description to indicate the circuit, component, or system area that was determined to be at fault. The descriptions are organized such that different descriptions related to a particular sensor or system are grouped together. In cases where there are various fault descriptions for different types of faults, the group also has a “generic” description as the first code/message of the group. A manufacturer has a choice when implementing diagnostics, based on the specific strategy and complexity of the diagnostic.

Where more specific fault descriptions for a circuit, component, or system exist, the manufacturer should choose the DTC most applicable to their diagnosable fault. The descriptions are intended to be somewhat general to allow manufacturers to use them as often as possible yet still not conflict with their specific repair procedures. The terms “low” and “high” when used in a description, especially those related to input signals, refer to the voltage, frequency, etc. at the pin of the controller. The specific level of “low” and “high” shall be specified by each manufacturer to best meet their needs.

For example, in diagnosing a 5 V reference throttle position sensor (TP sensor), if the input signal at the powertrain control module (PCM) is stuck at near 0 V, a manufacturer has the flexibility to select from either of two codes - P0120 (throttle/pedal position sensor/switch A circuit) or P0122 (throttle/pedal position sensor/switch A circuit low), depending on the manufacturer's diagnostic procedures. If the input signal at the PCM is stuck at near 5 V, a manufacturer has the flexibility to select from either of two codes - P0120 (throttle/pedal position sensor/switch A circuit) or P0123 (throttle/pedal position sensor/switch A circuit high), depending on the manufacturer's diagnostic procedures. If the input signal at the PCM is stuck at 1,5 V at idle instead of the expected 1,0 V, the manufacturer has the flexibility to select from either of two codes - P0120 (throttle/pedal position sensor/switch A circuit) or P0121 (throttle/pedal position sensor/switch A circuit range/performance), depending on the manufacturer's diagnostic procedures. The root cause of the higher than expected TP sensor voltage might be either a faulty TP sensor, corrosion in the TP sensor connections, or an improperly adjusted throttle plate. Identification of the root cause is done using the diagnostic procedures and is not implied by the DTC message, thus allowing the manufacturer the flexibility in assigning DTCs.

### 8.3 Body systems

The body systems category covers functions that are, generally, inside of the passenger compartment. These functions provide the vehicle occupants with assistance, comfort, convenience, and safety. Each specified trouble code has been assigned a description to indicate the component or system area that was determined to be at fault. Unlike powertrain systems, the body system trouble code descriptions are intended to be general. Powertrain DTCs typically include separate DTCs for each failure mode (e.g. circuit low, circuit high, rationality, etc.) within each DTC description. Body system DTCs are designed to only support the base component in the description, which makes these DTCs dependent upon diagnostic protocols that support a subfault failure strategy. Manufacturers shall select the appropriate failure mode (e.g. circuit short to ground, circuit short to battery, signal plausibility failure, etc.) to apply to the general DTC description. The supported body subsection included in this group is Restraints.

### 8.4 Chassis systems

The chassis systems category covers functions that are, generally, outside of the passenger compartment. These functions typically include mechanical systems such as brakes, steering, and suspension. Each specified trouble code has been assigned a description to indicate the component or system area that was determined to be at fault. Unlike powertrain systems, the chassis system trouble code descriptions are intended to be general. Powertrain DTCs typically include separate DTCs for each failure mode (e.g. circuit low, circuit high, rationality, etc.) within each DTC description. Chassis system DTCs are designed to only support the base component in the description, which makes these DTCs dependent upon diagnostic protocols that support a subfault failure strategy. Manufacturers shall select the appropriate failure mode (e.g. circuit short to ground, circuit short to battery, signal plausibility failure, etc.) to apply to the general DTC description. The supported chassis subsections included in this group are Brakes and Traction Control.

### 8.5 Network and vehicle integration systems

The network communication and vehicle integration systems category covers functions that are shared among computers or systems on the vehicle. Each specified trouble code has been assigned a description to indicate the component or system area that was determined to be at fault. The descriptions of data links are intended to be general in order to allow manufacturers to use them for different communication protocols. The descriptions of control modules are intended to be general in order to allow manufacturers to reuse the DTC for new control modules as technologies evolve. Also, the descriptions may be supplemented with additional subfault information such as the "failure type byte" data defined in SAE J2012-DA. The subclauses included in this group are Network Electrical, Network Communication, Network Software, Network Data, and Control Module/Power Distribution.

## Annex A (normative)

### Diagnostic trouble code naming guidelines

#### A.1 Discussion

SAE J2012-DA shows applications for recommended industry common trouble codes for the body systems, chassis systems, powertrain systems, and vehicle network and vehicle integration control systems. The powertrain DTCs in SAE J2012-DA include systems that might be integrated into an electronic control module that would be used for controlling engine functions, such as fuel, spark, idle speed, and vehicle speed (cruise control), as well as those for transmission control. The fact that a code is recommended as a common industry code does not imply that it is a required code (legislated), an emission-related code, nor does it indicate a fault that will cause the malfunction indicator to be illuminated.

[Table A.1](#) provides guidelines to help in determining DTC descriptions.

**Table A.1 — DTC naming guidelines for signals from components**

Component/ System ISO 15031-2/ SAE J1930 <sup>a</sup>	Acronym ISO 15031-2/ SAE J1930 <sup>a</sup>	Modifier (if used) <sup>a</sup>	Noun name <sup>a</sup>	Circuit <sup>a</sup>	Intermittent (if used) <sup>a</sup>	State (if used) <sup>a</sup>	Parameter (if used) <sup>a</sup>	Location (if used) <sup>a</sup>
Throttle position	TP		Sensor	Circuit		Low	Voltage	
Throttle position	TP		Sensor	Circuit		Performance		
Manifold absolute pressure	MAP		Sensor	Circuit		High	Voltage	
Engine coolant temperature	ECT		Sensor	Circuit		Low	Voltage	
Intake air temperature	IAT		Sensor	Circuit		High	Voltage	
Vehicle speed sensor	VSS		Included in acronym	Circuit		High	Voltage	
Vehicle speed sensor	VSS		Included in acronym	Circuit	Intermittent			
Heated oxygen sensor	HO2S		Included in acronym	Circuit				
Heated oxygen sensor	HO2S		Included in acronym	Circuit		Low	Voltage	Bank (B1) Sensor 1 (S1)
Idle air control	IAC		Valve	Circuit		Low	Voltage	
Mass air flow	MAF		Sensor	Circuit		High	Frequency	
Mass air flow	MAF		Sensor	Circuit		Performance		

<sup>a</sup> The service information uses component/system from ISO 15031-2/SAE J1930 or acronym from ISO 15031-2/SAE J1930, modifier, noun name, circuit, intermittent, state, parameter, and location.



**Table A.1** (continued)

Component/ System ISO 15031-2/ SAE J1930 <sup>a</sup>	Acronym ISO 15031-2/ SAE J1930 <sup>a</sup>	Modifier (if used) <sup>a</sup>	Noun name <sup>a</sup>	Circuit <sup>a</sup>	Intermittent (if used) <sup>a</sup>	State (if used) <sup>a</sup>	Parameter (if used) <sup>a</sup>	Location (if used) <sup>a</sup>
Knock sensor	KS		Included in acro- nym	Circuit				Bank 1
Knock sensor	KS		Included in acronym	Circuit		Performance		
Crankshaft position	CKP		Sensor	Circuit				
Evaporative emissions	EVAP	Canister purge	Valve	Circuit				
Engine speed	RPM		Input	Circuit				
Air conditioning	A/C	Clutch status	N/A	Circuit		Low	Voltage	
Heated oxygen sensor	HO2S		Included in acronym	Circuit		Transition time ratio		Bank 1 (B1) Sensor 1 (S1)
Heated oxygen sensor	HO2S		Included in acronym	Circuit		Insufficient switching		Bank 1 (B1) Sensor 1 (S1)
Distributor ignition	DI	Low resolution		Circuit	Intermittent			
Distributor ignition	DI	High resolution		Circuit				

<sup>a</sup> The service information uses component/system from ISO 15031-2/SAE J1930 or acronym from ISO 15031-2/SAE J1930, modifier, noun name, circuit, intermittent, state, parameter, and location.

Table A.2 defines the DTC naming guidelines for signals to components.

**Table A.2 — DTC naming guidelines for signals to components**

Component/ System ISO 15031-2/ SAE J1930 <sup>a</sup>	Acronym ISO 15031-2/ SAE J1930 <sup>a</sup>	Modifier (if used) <sup>a</sup>	Noun name <sup>a</sup>	Control <sup>a</sup>	Circuit <sup>a</sup>	Intermittent (if used) <sup>a</sup>	State (if used) <sup>a</sup>	Parameter (if used) <sup>a</sup>	Location (if used) <sup>a</sup>
Malfunction indicator lamp	MIL		Included in acronym	Control	Circuit				
Injector	N/A		N/A	Control	Circuit				
Fan control	FC	1		Control	Circuit				
Fan control	FC	2		Control	Circuit		Low		
Exhaust gas recirculation	EGR		Solenoid	Control	Circuit		High		
Secondary air injection	AIR		Solenoid	Control	Circuit		High		
Evaporative emissions	EVAP	Purge	Solenoid	Control	Circuit				
Air conditioning	A/C	Clutch	Relay	Control	Circuit				
Idle air control	IAC		Valve	Control	Circuit		Low		

<sup>a</sup> The service information uses component/system from ISO 15031-2/SAE J1930 or acronym from ISO 15031-2/SAE J1930, modifier, noun name, circuit, intermittent, state, parameter, and location.



**Table A.2 (continued)**

Component/ System ISO 15031-2/ SAE J1930 <sup>a</sup>	Acronym ISO 15031-2/ SAE J1930 <sup>a</sup>	Modifier (if used) <sup>a</sup>	Noun name <sup>a</sup>	Control <sup>a</sup>	Circuit <sup>a</sup>	Intermittent (if used) <sup>a</sup>	State (if used) <sup>a</sup>	Parameter (if used) <sup>a</sup>	Location (if used) <sup>a</sup>
Ignition control	IC		N/A	Included in acronym	Circuit		Low	Voltage	
Ignition control	IC		N/A	Included in acronym	Circuit		High	Voltage	
Torque converter clutch	TCC		Solenoid	Control	Circuit		Stuck on		

<sup>a</sup> The service information uses component/system from ISO 15031-2/SAE J1930 or acronym from ISO 15031-2/SAE J1930, modifier, noun name, circuit, intermittent, state, parameter, and location.

[Table A.3](#) defines the DTC naming guidelines involving several components or systems.

**Table A.3 — DTC naming guidelines involving several components or systems**

Component/ System ISO 15031-2/ SAE, J1930 <sup>a</sup>	Acronym ISO 15031-2/ SAE J1930 <sup>a</sup>	Modifier <sup>a</sup>	System <sup>a</sup>	Intermittent <sup>a</sup>	State <sup>a</sup>	Parameter <sup>a</sup>	Location <sup>a</sup>
Exhaust gas recirculation	EGR		System				
Fuel trim	FT		System		Lean		Bank 1
Secondary air injection	AIR		System				Bank 1

<sup>a</sup> The service information uses component/system from ISO 15031-2/SAE J1930 or acronym from ISO 15031-2/SAE J1930, modifier, noun name, circuit, intermittent, state, parameter, and location.

[Table A.4](#) defines the DTC naming guidelines for signals using a subfault strategy.

**Table A.4 — DTC naming guidelines for signals using a subfault strategy**

Location	Component/ System ISO 15031-2/ SAE J1930 <sup>a</sup>	Acronym ISO 15031-2/ SAE J1930 <sup>a</sup>	Modifier (if used) <sup>a</sup>	Noun name <sup>a</sup>	Subfault failure type <sup>b</sup>
Left front	Wheel		Speed	Sensor	Signal amplitude < minimum
Passenger	Seat		Occupant classification	Sensor	Circuit open
Second row left	Seatbelt			Sensor	No subtype information
Driver	Frontal		Stage 1	Deployment control	Circuit resistance out of range

<sup>a</sup> The service information uses location, component/system from ISO 15031-2/SAE J1930 or acronym from ISO 15031-2/SAE J1930, modifier, noun name, and subfault failure type.

<sup>b</sup> These DTCs require the addition of a failure mode supported via a diagnostic protocol (e.g. ISO 14229-1), which supports DTC subfaults. These are not intended to be used with protocols that do not support a subfault strategy. Reference appendix FTB for recommended failure type byte assignments.

## Bibliography

- [1] ISO 27145-2, *Road vehicles — Implementation of World-Wide Harmonized On-Board Diagnostics (WWH-OBD) communication requirements — Part 2: Common data dictionary*
- [2] ISO 14229-1, *Road vehicles — Unified diagnostic services (UDS) — Part 1: Specification and requirements*
- [3] ISO 14229-2, *Road vehicles — Unified diagnostic services (UDS) — Part 2: Session layer services*
- [4] ISO 7498-1:1994, *Information technology — Open Systems Interconnection — Basic Reference Model: The Basic Model*
- [5] ISO 15031-1, *Road vehicles — Communication between vehicle and external equipment for emissions-related diagnostics — Part 1: General information and use case definition*
- [6] SAE J1930, *Electrical/Electronic Systems Diagnostic Terms, Definitions, Abbreviations, and Acronyms*
- [7] SAE J1930-DA, *Digital Annex of Electrical/Electronic Systems Diagnostic Terms, Definitions, Abbreviations, and Acronyms*
- [8] SAE J1979, *E/E Diagnostic Test Modes*
- [9] SAE J1979-DA, *Digital Annex of E/E Diagnostic Test Modes*
- [10] SAE J2012, *Diagnostic Trouble Code Definitions*
- [11] SAE J2012-DA, *Digital Annex of Diagnostic Trouble Code Definitions and Failure Type Byte Definitions*







# British Standards Institution (BSI)

BSI is the national body responsible for preparing British Standards and other standards-related publications, information and services.

BSI is incorporated by Royal Charter. British Standards and other standardization products are published by BSI Standards Limited.

## About us

We bring together business, industry, government, consumers, innovators and others to shape their combined experience and expertise into standards-based solutions.

The knowledge embodied in our standards has been carefully assembled in a dependable format and refined through our open consultation process. Organizations of all sizes and across all sectors choose standards to help them achieve their goals.

## Information on standards

We can provide you with the knowledge that your organization needs to succeed. Find out more about British Standards by visiting our website at [bsigroup.com/standards](http://bsigroup.com/standards) or contacting our Customer Services team or Knowledge Centre.

## Buying standards

You can buy and download PDF versions of BSI publications, including British and adopted European and international standards, through our website at [bsigroup.com/shop](http://bsigroup.com/shop), where hard copies can also be purchased.

If you need international and foreign standards from other Standards Development Organizations, hard copies can be ordered from our Customer Services team.

## Subscriptions

Our range of subscription services are designed to make using standards easier for you. For further information on our subscription products go to [bsigroup.com/subscriptions](http://bsigroup.com/subscriptions).

With **British Standards Online (BSOL)** you'll have instant access to over 55,000 British and adopted European and international standards from your desktop. It's available 24/7 and is refreshed daily so you'll always be up to date.

You can keep in touch with standards developments and receive substantial discounts on the purchase price of standards, both in single copy and subscription format, by becoming a **BSI Subscribing Member**.

**PLUS** is an updating service exclusive to BSI Subscribing Members. You will automatically receive the latest hard copy of your standards when they're revised or replaced.

To find out more about becoming a BSI Subscribing Member and the benefits of membership, please visit [bsigroup.com/shop](http://bsigroup.com/shop).

With a **Multi-User Network Licence (MUNL)** you are able to host standards publications on your intranet. Licences can cover as few or as many users as you wish. With updates supplied as soon as they're available, you can be sure your documentation is current. For further information, email [bsmusales@bsigroup.com](mailto:bsmusales@bsigroup.com).

## BSI Group Headquarters

389 Chiswick High Road London W4 4AL UK

## Revisions

Our British Standards and other publications are updated by amendment or revision.

We continually improve the quality of our products and services to benefit your business. If you find an inaccuracy or ambiguity within a British Standard or other BSI publication please inform the Knowledge Centre.

## Copyright

All the data, software and documentation set out in all British Standards and other BSI publications are the property of and copyrighted by BSI, or some person or entity that owns copyright in the information used (such as the international standardization bodies) and has formally licensed such information to BSI for commercial publication and use. Except as permitted under the Copyright, Designs and Patents Act 1988 no extract may be reproduced, stored in a retrieval system or transmitted in any form or by any means – electronic, photocopying, recording or otherwise – without prior written permission from BSI. Details and advice can be obtained from the Copyright & Licensing Department.

## Useful Contacts:

### Customer Services

**Tel:** +44 845 086 9001

**Email (orders):** [orders@bsigroup.com](mailto:orders@bsigroup.com)

**Email (enquiries):** [cservices@bsigroup.com](mailto:cservices@bsigroup.com)

### Subscriptions

**Tel:** +44 845 086 9001

**Email:** [subscriptions@bsigroup.com](mailto:subscriptions@bsigroup.com)

### Knowledge Centre

**Tel:** +44 20 8996 7004

**Email:** [knowledgecentre@bsigroup.com](mailto:knowledgecentre@bsigroup.com)

### Copyright & Licensing

**Tel:** +44 20 8996 7070

**Email:** [copyright@bsigroup.com](mailto:copyright@bsigroup.com)



...making excellence a habit.™