

BS ISO 14960-2:2014



BSI Standards Publication

Tubeless tyres — Valves and components

Part 2: Clamp-in tubeless tyre valve-test method

bsi.

...making excellence a habit.™

National foreword

This British Standard is the UK implementation of ISO 14960-2:2014.

The UK participation in its preparation was entrusted to Technical Committee AUE/4, Tyres and wheels for motor vehicles.

A list of organizations represented on this committee can be obtained on request to its secretary.

This publication does not purport to include all the necessary provisions of a contract. Users are responsible for its correct application.

© The British Standards Institution 2014. Published by BSI Standards Limited 2014

ISBN 978 0 580 83207 9

ICS 83.160.01

Compliance with a British Standard cannot confer immunity from legal obligations.

This British Standard was published under the authority of the Standards Policy and Strategy Committee on 30 November 2014.

Amendments issued since publication

Date	Text affected
------	---------------

INTERNATIONAL
STANDARD

ISO
14960-2

First edition
2014-11-01

**Tubeless tyres — Valves and
components —**

Part 2:
**Clamp-in tubeless tyre valve-test
method**

*Pneumatiques sans chambre — Valves et composants —
Partie 2: Méthodes d'essai pour les valves à visser*



Reference number
ISO 14960-2:2014(E)

© ISO 2014



COPYRIGHT PROTECTED DOCUMENT

© ISO 2014

All rights reserved. Unless otherwise specified, no part of this publication may be reproduced or utilized otherwise in any form or by any means, electronic or mechanical, including photocopying, or posting on the internet or an intranet, without prior written permission. Permission can be requested from either ISO at the address below or ISO's member body in the country of the requester.

ISO copyright office
Case postale 56 • CH-1211 Geneva 20
Tel. + 41 22 749 01 11
Fax + 41 22 749 09 47
E-mail copyright@iso.org
Web www.iso.org

Published in Switzerland

Contents

Page

Foreword	iv
1 Scope	1
2 Normative references	1
3 Test methods and performance requirements	1
3.1 Valve core.....	1
3.2 Valve cap seal.....	3
3.3 Valve-to-rim seal.....	3
3.4 Valve mechanical resistance.....	5
3.5 Environmental resistance.....	5
Bibliography	7

Foreword

ISO (the International Organization for Standardization) is a worldwide federation of national standards bodies (ISO member bodies). The work of preparing International Standards is normally carried out through ISO technical committees. Each member body interested in a subject for which a technical committee has been established has the right to be represented on that committee. International organizations, governmental and non-governmental, in liaison with ISO, also take part in the work. ISO collaborates closely with the International Electrotechnical Commission (IEC) on all matters of electrotechnical standardization.

The procedures used to develop this document and those intended for its further maintenance are described in the ISO/IEC Directives, Part 1. In particular the different approval criteria needed for the different types of ISO documents should be noted. This document was drafted in accordance with the editorial rules of the ISO/IEC Directives, Part 2 (see www.iso.org/directives).

Attention is drawn to the possibility that some of the elements of this document may be the subject of patent rights. ISO shall not be held responsible for identifying any or all such patent rights. Details of any patent rights identified during the development of the document will be in the Introduction and/or on the ISO list of patent declarations received (see www.iso.org/patents).

Any trade name used in this document is information given for the convenience of users and does not constitute an endorsement.

For an explanation on the meaning of ISO specific terms and expressions related to conformity assessment, as well as information about ISO's adherence to the WTO principles in the Technical Barriers to Trade (TBT) see the following URL: [Foreword - Supplementary information](#).

The committee responsible for this document is Technical Committee ISO/TC 31, *Tyres, rims and valves*, Subcommittee SC 9, *Valves for tube and tubeless tyres*.

This first edition of ISO 14960-2, together with ISO 14960-1, cancels and replaces ISO 14960:2004, which has been technically revised.

ISO 14960 consists of the following parts, under the general title *Tubeless tyres — Valves and components*:

- *Part 1: Test methods*
- *Part 2: Clamp-in tubeless tyre valve-test method*

Tubeless tyres — Valves and components —

Part 2:

Clamp-in tubeless tyre valve-test method

1 Scope

This part of ISO 14960 establishes minimum specifications for clamp-in tubeless tire valves. A clamp-in valve is an assembly of a valve stem, valve core, valve cap, rubber grommet or O-ring, hex nut, and ring washer which conforms to ISO 9413.

2 Normative references

The following documents, in whole or in part, are normatively referenced in this document and are indispensable for its application. For dated references, only the edition cited applies. For undated references, the latest edition of the referenced document (including any amendments) applies.

ISO 9413, *Tyre valves — Dimensions and designation*

ISO 9227, *Corrosion tests in artificial atmospheres — Salt spray tests*

3 Test methods and performance requirements

3.1 Valve core

3.1.1 Valve core specifications

Valve cores installed in clamp-in valve assemblies (see [Figure 1](#)) shall have a pin height tolerance of $\begin{matrix} +0,25 \\ -0,90 \end{matrix}$ mm, relative to the valve mouth, and a standard torque of 0,23 N m to 0,34 N m.

3.1.2 Room temperature test

3.1.2.1 Test procedure

- a) Immerse the valve assembly vertically in clean water at $23\text{ °C} \pm 5\text{ °C}$ not more than 25 mm below the surface of the water (see [Figure 1](#)).
- b) Check for leakage using a pressure of $35\text{ kPa} \pm 5\text{ kPa}$.

3.1.2.2 Performance requirement

The leak rate shall not be greater than $0,2\text{ cm}^3/\text{min}$.

3.1.3 Low temperature test

3.1.3.1 Test procedure

- a) Depress and release the valve core pin once after a 24 h minimum exposure at $-40\text{ °C} \pm 3\text{ °C}$; maintain pressure at $180\text{ kPa} \pm 15\text{ kPa}$. See [Figure 1](#).

- b) Immerse the valve assembly vertically in ethanol or methanol at $-40\text{ °C} \pm 3\text{ °C}$ not more than 25 mm below the surface with the pressure maintained at $180\text{ kPa} \pm 15\text{ kPa}$.
- c) Begin leak detection after a 1 min soak period.
- d) Increase pressure to $1,4\text{ MPa} \pm 0,15\text{ MPa}$.
- e) Begin leak detection after 1 min soak period.

3.1.3.2 Performance requirement

The leak rate shall not be greater than $0,2\text{ cm}^3/\text{min}$.

3.1.4 High temperature test

3.1.4.1 Test procedure

- a) Depress and release the valve core pin once after a 48 h minimum soak period at $100\text{ °C} \pm 3\text{ °C}$; maintain pressure at $1,4\text{ MPa} \pm 0,15\text{ MPa}$. See [Figure 1](#).
- b) Check for leakage with $66\text{ °C} \pm 3\text{ °C}$ clean water at not more than 25 mm above the valve mouth, with the pressure maintained at $1,4\text{ MPa} \pm 0,15\text{ MPa}$.

3.1.4.2 Performance requirement

The leak rate shall not be greater than $0,2\text{ cm}^3/\text{min}$.

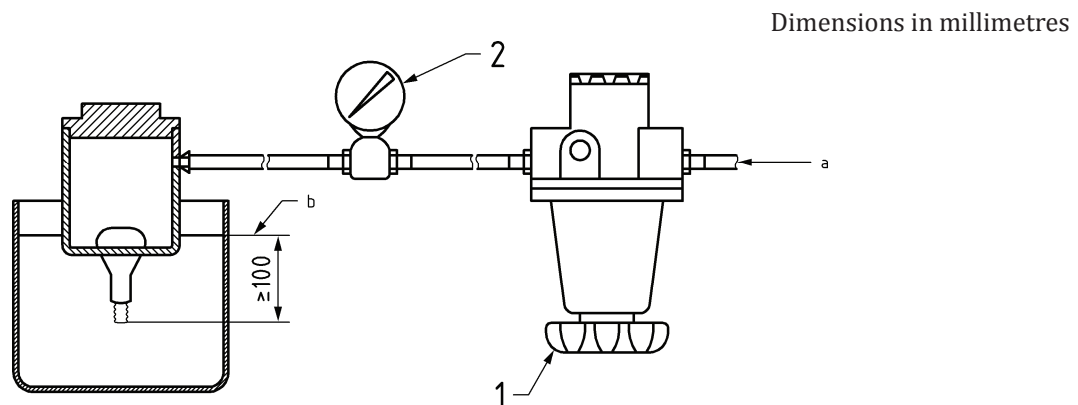

Key

- 1 regulator
- 2 gauge
- a Air supply.
- b Liquid level.

Figure 1 — Valve seal test set-up

3.1.5 Valve core torque test

3.1.5.1 Test procedure

With a calibrated torque wrench, torque the core on the valve twice the maximum specified torque. Remove the core and examine for separation of the swivel from the barrel, and barrel gasket from the barrel.

3.1.5.2 Performance requirement

The core shall come out of the valve without separation.

3.1.6 Cycle test

3.1.6.1 Test procedure

- a) With the valve pressurized to 1,4 MPa, depress the valve core pin to its maximum travel 120 times.
- b) Immerse the valve assembly vertically in clean water at $23\text{ °C} \pm 5\text{ °C}$ not more than 25 mm below the surface of the water (see [Figure 1](#)).
- c) Check for leakage using a pressure of $1,4\text{ MPa} \pm 0,15\text{ MPa}$.

3.1.6.2 Performance requirement

The leak rate shall not be greater than $0,2\text{ cm}^3/\text{min}$.

3.1.7 Air flow test

3.1.7.1 Test procedure

The valve with core shall be attached to a standard inflation chuck with depressor pin. Measure the air flow through the tire valve with 690 kPa pressure applied.

3.1.7.2 Performance requirement

The valve shall flow a minimum of 100 l/min.

3.2 Valve cap seal

3.2.1 Room temperature test (optional, for sealing caps only)

3.2.1.1 Test procedure

- a) Screw the cap with a sealing gasket at 0,15 N m to 0,20 N m torque on a valve without a core.
- b) Immerse the valve assembly vertically in clean water at $23\text{ °C} \pm 5\text{ °C}$ not more than 25 mm below the surface of the water (see [Figure 1](#)).
- c) Check for leakage using a $1,4\text{ MPa} \pm 0,15\text{ MPa}$ test pressure.

3.2.1.2 Performance requirement

The leak rate shall not be greater than $0,2\text{ cm}^3/\text{min}$.

3.3 Valve-to-rim seal

3.3.1 Temperature Test

Valves with grommets shall be tested in accordance with the [Table 1](#).

It is not required to test valves with O-rings to the maximum and minimum values of rim hole diameter and rim thickness.

Minimum and maximum values are according to ISO 9413 for the particular valve being tested.

Table 1 — Temperature test

Trial	Factor		
	Rim hole diameter	Rim thickness	Installation torque
1	Maximum $\begin{matrix} 0 \\ -0,05 \end{matrix}$	Minimum $\pm 0,05$	Minimum $\pm 5\%$
2	Maximum $\begin{matrix} 0 \\ -0,05 \end{matrix}$	Maximum $\pm 0,05$	Maximum $\pm 5\%$
3	Minimum $\begin{matrix} +0,05 \\ 0 \end{matrix}$	Minimum $\pm 0,05$	Maximum $\pm 5\%$
4	Minimum $\begin{matrix} +0,05 \\ 0 \end{matrix}$	Maximum $\pm 0,05$	Minimum $\pm 5\%$

3.3.2 Low temperature test

3.3.2.1 Test procedure

- a) Subject the valves to $-40\text{ °C} \pm 3\text{ °C}$ for 24 h at $180\text{ kPa} \pm 15\text{ kPa}$.
- b) Immerse the valve assembly vertically in ethanol or methanol at $-40\text{ °C} \pm 3\text{ °C}$ not more than 25 mm below the surface with the pressure maintained at $180\text{ kPa} \pm 15\text{ kPa}$. See [Figure 1](#).
- c) Begin leak detection after a 1 min period.
- d) Increase pressure to $1,4\text{ MPa} \pm 0,15\text{ MPa}$.
- e) Begin leak detection after 1 min period.

3.3.2.2 Performance requirement

The leak rate shall not be greater than $0,2\text{ cm}^3/\text{min}$.

3.3.3 High temperature test

3.3.3.1 Test procedure

- a) Subject the valves to $100\text{ °C} \pm 3\text{ °C}$ for 72 h at $1,4\text{ MPa} \pm 0,15\text{ MPa}$.
- b) Check for leakage with $66\text{ °C} \pm 3\text{ °C}$ clean water at not more than 25 mm above the valve mouth, with the pressure maintained at $1,4\text{ MPa} \pm 0,15\text{ MPa}$. See [Figure 1](#).

3.3.3.2 Performance requirement

The leak rate shall not be greater than $0,2\text{ cm}^3/\text{min}$.

3.3.4 Peak temperature test

3.3.4.1 Test procedure

Subject the valves to $135\text{ °C} \pm 3\text{ °C}$ at $1,4\text{ MPa}$ for 1 h.

Submerge the fixture in water at $66\text{ °C} \pm 3\text{ °C}$ and check for leakage at the valve core and grommet/rim interface.

3.3.4.2 Performance requirement

The leak rate shall not be greater than 0,2 cm³/min.

3.4 Valve mechanical resistance

3.4.1 Torque test

3.4.1.1 Test procedure

Using a calibrated torque wrench, tighten the hex nut on the valve to two times the maximum installation torque given in ISO 9413, then unscrew immediately.

3.4.1.2 Performance requirement

No mechanical breakage of either the nut or the valve is permitted.

3.4.2 High pressure test

3.4.2.1 Test procedure

At 23 °C ± 5 °C, apply 4,2 MPa pressure (pneumatic or hydraulic) to the valve. Maintain this pressure for 3 min.

3.4.2.2 Performance requirement

The valve shall not burst.

3.5 Environmental resistance

3.5.1 Ozone test

3.5.1.1 Test procedure

Age the seal (unmounted) for 72 h at 100 °C ± 3 °C.

Assemble the seal on a fixture 10 % larger than the stem diameter where the seal sits.

Expose the assembled seal to 100 ± 5 parts of ozone to 100 million parts of air at 38 °C ± 3 °C for 72 h. Then, remove the seals from the ozone chamber and examine the rubber grommet or O-ring at a magnification of 5x for cracks.

3.5.1.2 Performance requirement

The rubber grommet shall not exhibit any cracks when viewed at a 5x magnification.

3.5.2 Salt fog test

3.5.2.1 Test procedure

Assemble valves on steel and alloy fixtures representative of real rims, and expose assemblies for 240 h minimum of salt fog in accordance with ISO 9227, NSS test.

3.5.2.2 Performance requirement

No corrosion shall alter the functionalities of the valve.

- The leak rate at 1,4 MPa shall not be greater than 0,2 cm³/min.
- The valve can be disassembled from the rim.

Bibliography

- [1] ISO 20562, *Tyre valves — ISO core chambers No. 1, No. 2, No. 3 and No. 4*

British Standards Institution (BSI)

BSI is the national body responsible for preparing British Standards and other standards-related publications, information and services.

BSI is incorporated by Royal Charter. British Standards and other standardization products are published by BSI Standards Limited.

About us

We bring together business, industry, government, consumers, innovators and others to shape their combined experience and expertise into standards-based solutions.

The knowledge embodied in our standards has been carefully assembled in a dependable format and refined through our open consultation process. Organizations of all sizes and across all sectors choose standards to help them achieve their goals.

Information on standards

We can provide you with the knowledge that your organization needs to succeed. Find out more about British Standards by visiting our website at bsigroup.com/standards or contacting our Customer Services team or Knowledge Centre.

Buying standards

You can buy and download PDF versions of BSI publications, including British and adopted European and international standards, through our website at bsigroup.com/shop, where hard copies can also be purchased.

If you need international and foreign standards from other Standards Development Organizations, hard copies can be ordered from our Customer Services team.

Subscriptions

Our range of subscription services are designed to make using standards easier for you. For further information on our subscription products go to bsigroup.com/subscriptions.

With **British Standards Online (BSOL)** you'll have instant access to over 55,000 British and adopted European and international standards from your desktop. It's available 24/7 and is refreshed daily so you'll always be up to date.

You can keep in touch with standards developments and receive substantial discounts on the purchase price of standards, both in single copy and subscription format, by becoming a **BSI Subscribing Member**.

PLUS is an updating service exclusive to BSI Subscribing Members. You will automatically receive the latest hard copy of your standards when they're revised or replaced.

To find out more about becoming a BSI Subscribing Member and the benefits of membership, please visit bsigroup.com/shop.

With a **Multi-User Network Licence (MUNL)** you are able to host standards publications on your intranet. Licences can cover as few or as many users as you wish. With updates supplied as soon as they're available, you can be sure your documentation is current. For further information, email bsmusales@bsigroup.com.

BSI Group Headquarters

389 Chiswick High Road London W4 4AL UK

Revisions

Our British Standards and other publications are updated by amendment or revision.

We continually improve the quality of our products and services to benefit your business. If you find an inaccuracy or ambiguity within a British Standard or other BSI publication please inform the Knowledge Centre.

Copyright

All the data, software and documentation set out in all British Standards and other BSI publications are the property of and copyrighted by BSI, or some person or entity that owns copyright in the information used (such as the international standardization bodies) and has formally licensed such information to BSI for commercial publication and use. Except as permitted under the Copyright, Designs and Patents Act 1988 no extract may be reproduced, stored in a retrieval system or transmitted in any form or by any means – electronic, photocopying, recording or otherwise – without prior written permission from BSI. Details and advice can be obtained from the Copyright & Licensing Department.

Useful Contacts:

Customer Services

Tel: +44 845 086 9001

Email (orders): orders@bsigroup.com

Email (enquiries): cservices@bsigroup.com

Subscriptions

Tel: +44 845 086 9001

Email: subscriptions@bsigroup.com

Knowledge Centre

Tel: +44 20 8996 7004

Email: knowledgecentre@bsigroup.com

Copyright & Licensing

Tel: +44 20 8996 7070

Email: copyright@bsigroup.com



...making excellence a habit.™