

BS ISO 14960-1:2014



BSI Standards Publication

Tubeless tyres — Valves and components

Part 1: Test methods

bsi.

...making excellence a habit.™

National foreword

This British Standard is the UK implementation of ISO 14960-1:2014.

The UK participation in its preparation was entrusted to Technical Committee AUE/4, Tyres and wheels for motor vehicles.

A list of organizations represented on this committee can be obtained on request to its secretary.

This publication does not purport to include all the necessary provisions of a contract. Users are responsible for its correct application.

© The British Standards Institution 2014. Published by BSI Standards Limited 2014

ISBN 978 0 580 83206 2

ICS 83.160.01

Compliance with a British Standard cannot confer immunity from legal obligations.

This British Standard was published under the authority of the Standards Policy and Strategy Committee on 30 November 2014.

Amendments issued since publication

Date	Text affected
------	---------------

INTERNATIONAL
STANDARD

ISO
14960-1

First edition
2014-11-01

**Tubeless tyres — Valves and
components —**

Part 1:
Test methods

*Pneumatiques sans chambre — Valves et composants —
Partie 1: Méthodes d'essai*



Reference number
ISO 14960-1:2014(E)

© ISO 2014



COPYRIGHT PROTECTED DOCUMENT

© ISO 2014

All rights reserved. Unless otherwise specified, no part of this publication may be reproduced or utilized otherwise in any form or by any means, electronic or mechanical, including photocopying, or posting on the internet or an intranet, without prior written permission. Permission can be requested from either ISO at the address below or ISO's member body in the country of the requester.

ISO copyright office
Case postale 56 • CH-1211 Geneva 20
Tel. + 41 22 749 01 11
Fax + 41 22 749 09 47
E-mail copyright@iso.org
Web www.iso.org

Published in Switzerland

Contents

Page

Foreword	iv
1 Scope	1
2 Normative references	1
3 Terms and definitions	1
4 Methods for testing tubeless tyres snap-in valves	1
4.1 Description of a snap-in valve.....	1
4.2 Test fixtures	1
4.3 Installation.....	2
4.4 Limit case for valves	2
5 Test methods and performances requirements	2
5.1 Adhesion.....	2
5.2 Valve core seal.....	3
5.3 Valve cap seal (optional, for sealing caps only).....	4
5.4 Valve to rim seal	5
5.5 Installation tests	7
5.6 Burst.....	8
5.7 Ozone resistance.....	8
5.8 Flexing resistance	9
Bibliography	10

Foreword

ISO (the International Organization for Standardization) is a worldwide federation of national standards bodies (ISO member bodies). The work of preparing International Standards is normally carried out through ISO technical committees. Each member body interested in a subject for which a technical committee has been established has the right to be represented on that committee. International organizations, governmental and non-governmental, in liaison with ISO, also take part in the work. ISO collaborates closely with the International Electrotechnical Commission (IEC) on all matters of electrotechnical standardization.

The procedures used to develop this document and those intended for its further maintenance are described in the ISO/IEC Directives, Part 1. In particular the different approval criteria needed for the different types of ISO documents should be noted. This document was drafted in accordance with the editorial rules of the ISO/IEC Directives, Part 2 (see www.iso.org/directives).

Attention is drawn to the possibility that some of the elements of this document may be the subject of patent rights. ISO shall not be held responsible for identifying any or all such patent rights. Details of any patent rights identified during the development of the document will be in the Introduction and/or on the ISO list of patent declarations received (see www.iso.org/patents).

Any trade name used in this document is information given for the convenience of users and does not constitute an endorsement.

For an explanation on the meaning of ISO specific terms and expressions related to conformity assessment, as well as information about ISO's adherence to the WTO principles in the Technical Barriers to Trade (TBT) see the following URL: [Foreword - Supplementary information](#).

The committee responsible for this document is ISO/TC 31, *Tyres, rims and valves*, Subcommittee SC 9, *Valves for tube and tubeless tyres*.

This first edition of ISO 14960-1, together with ISO 14960-2, cancels and replaces ISO 14960:2004, which has been technically revised.

ISO 14960 consists of the following parts, under the general title *Tubeless tyres — Valves and components*:

- *Part 1: Test methods*
- *Part 2: Clamp-in tubeless tyre valve-test method*

Tubeless tyres — Valves and components —

Part 1: Test methods

1 Scope

This part of ISO 14960 specifies test methods for snap-in tubeless tyre valves intended for, but are not limited to, highway applications.

2 Normative references

The following documents, in whole or in part, are normatively referenced in this document and are indispensable for its application. For dated references, only the edition cited applies. For undated references, the latest edition of the referenced document (including any amendments) applies.

ISO 3877-2, *Tyres, valves and tubes — List of equivalent terms — Part 2: Tyre valves*

3 Terms and definitions

For the purposes of this document, the terms and definitions given in ISO 3877-2 and the following apply.

3.1

snap-in valve

tyre valve having a rigid housing adhered to a resilient body designed to retain and seal the valve in the rim hole

4 Methods for testing tubeless tyres snap-in valves

4.1 Description of a snap-in valve

A snap-in valve is a unit free of rubber in the air passage, no rubber or cement above the second thread on the housing, and without flow cracks, blisters, voids, or other moulding defects. The mould parting line flash should not exceed 1,3 mm in height and 0,15 mm thickness at the outer edge.

4.2 Test fixtures

Break both edges on both sides of the valve hole either by a 45° chamfer or a radius from 0,3 mm to 0,4 mm. Emery cloth or suitable tooling is recommended. It is recommended that material of the test fixture be representative of the material of the actual rim.

The primary external seal of a “snap-in” valve in a valve hole is obtained from the rubber compression of the valve body onto the internal surface of the valve hole. Secondary external sealing may be present by the contact of the remainder of the valve body exterior to the surface of the material around the valve hole. Either of both of these seals can be affected by the compound curvatures in the wheel rims and by stock thickness. See [Table 1](#).

Table 1 — Test Fixtures

Dimensions in millimetres

Nominal hole	Diameter 11,3 mm		Diameter 15,7 mm	
	Test hole	Plate thickness	Test hole	Plate thickness
Valve to rim seal test low and high temperature test (see 5.4.1 and 5.4.2)	11,7 ⁺⁰ _{-0,05}	1,8 ± 0,05	16,1 ⁺⁰ _{-0,05}	1,8 ± 0,05
Installation tests (see 5.5.1 and 5.5.2)	11,3 ^{+0,05} ₋₀	3,5 ± 0,05	15,7 ^{+0,05} ₋₀	3,5 ± 0,05
Ozone resistance (see 5.7)	11,3 ^{+0,05} ₋₀	3,5 ± 0,05	15,7 ^{+0,05} ₋₀	3,5 ± 0,05
Burst or unseating (see 5.6) flexing resistance (see 5.8)	11,7 ⁺⁰ _{-0,05}	1,8 ± 0,05	16,1 ⁺⁰ _{-0,05}	1,8 ± 0,05

4.3 Installation

All valves, while wet with clean water as a lubricant, shall be installed in a proper test fixture by applying valve insertion force to the end of the valve metal insert or by applying valve traction force to the mouth of the valve perpendicular to the plane of the valve mounting hole and directly through the centre of the valve mounting hole. However, no valve assembly, which has damage resulting from installation, shall be tested.

A valve shall be considered properly seated when all of the indicator ring is observed to be through the rim or valve mounting hole fixture.

After installation, valve assemblies shall be thoroughly dried in the sealing area before continuing tests.

4.4 Limit case for valves

4.4.1 Unused valves are those that have completed final manufacturing processing at least 24 h previously, have not been subjected to any test or service, and have been stored for no longer than 4 months in the dark at ambient temperature, in an optimal and non-aggressive environment. Rubber compounds can change characteristics during their life expectancy.

4.4.2 For the purpose of this testing method, aged valves are those unused valves that have been subjected to 100 °C ± 3 °C for 4 h in circulating hot air and cooled at 20 °C to 26 °C for a minimum of 4 h.

5 Test methods and performances requirements

5.1 Adhesion

5.1.1 Test methods

- Make two axial, parallel cuts 180° apart through the full thickness of the rubber cover down the entire length of the valve.
- Pull each side of the button base away from the insert towards the cap thread end at 150 mm ± 15 mm per min with a traction machine.

The test shall be conducted at 23 °C ± 5 °C.

An alternative to the traction machine is to use pliers.

5.1.2 Performances

Any separation between brass and rubber, brass and cement, or cement and rubber in excess of 41 mm², on each valve, shall be considered as a failure.

Any separation that made a strip along the complete valve axis direction shall be considered as a failure.

5.2 Valve core seal

Valve cores installed in snap-in valve assemblies (see [Figure 1](#)) have the following characteristics:

- pin height tolerance: $\begin{matrix} +0,25 \\ -0,90 \end{matrix}$ (reference to valve mouth);
- standard torque:
 - 0,40 N m to 0,50 N m with metallic sealing;
 - 0,23 N m to 0,34 N m for non-metallic gasket.

5.2.1 Room temperature test

5.2.1.1 Test methods

Immerse valve assembly in clean water at 23 °C ± 5 °C with mouth down vertically and not more than 100 mm below the surface of the water (see [Figure 1](#)).

Check for leakage with test pressures as follows:

- a) cup gasket seal — apply 35 kPa air pressure;
- b) barrel seal — apply 475 kPa air pressure.

5.2.1.2 Performances

Leakage at a rate less than 0,2 cm³/min or no bubble detaching during the test time of 1 min is considered acceptable.

5.2.2 Low temperature test

5.2.2.1 Test methods

- a) Depress and release valve core pin once after a 24 h minimum exposure at -40 °C ± 3 °C, and assembly pressure shall be maintained to 180 kPa ± 15 kPa (see following [Figure 1](#)).
- b) Check for leakage with -40 °C ± 3 °C ethanol or methanol 25 mm above valve mouth, with assembly still pressurized to 180 kPa.
- c) Begin leak detection after 1 min soak period.

5.2.2.2 Performances

Leakage at a rate less than 0,2 cm³/min or no bubble detaching during the test time of 1 min is considered acceptable.

5.2.3 High temperature test

5.2.3.1 Test methods

(See [Figure 1](#).)

- a) Depress and release valve core pin once after a 48 h minimum soak period at $100\text{ °C} \pm 3\text{ °C}$, and assembly pressure shall be maintained to $600\text{ kPa} \pm 15\text{ kPa}$.
- b) Check for leakage with $66\text{ °C} \pm 3\text{ °C}$ clean water not more than 50 mm above the mouth of the valve with assembly still pressurized to 600 kPa.

5.2.3.2 Performances

Leakage at a rate less than $0,2\text{ cm}^3/\text{min}$ or no bubble detaching during the test time of 1 min is considered acceptable.

5.3 Valve cap seal (optional, for sealing caps only)

5.3.1 Room temperature test with cap

5.3.1.1 Test methods

- a) Screw the cap with sealing gasket at $0,15\text{ N m}$ to $0,20\text{ N m}$ torque on valve without core.
- b) Immerse valve assembly in clean water at $23\text{ °C} \pm 5\text{ °C}$ with mouth down vertically and not more than 100 mm below the surface of the water (see [Figure 1](#)).
- c) Check for leakage with 475 kPa test pressure.

5.3.1.2 Performances

Leakage at a rate less than $0,2\text{ cm}^3/\text{min}$ or no bubble detaching during the test time of 1 min is considered acceptable.

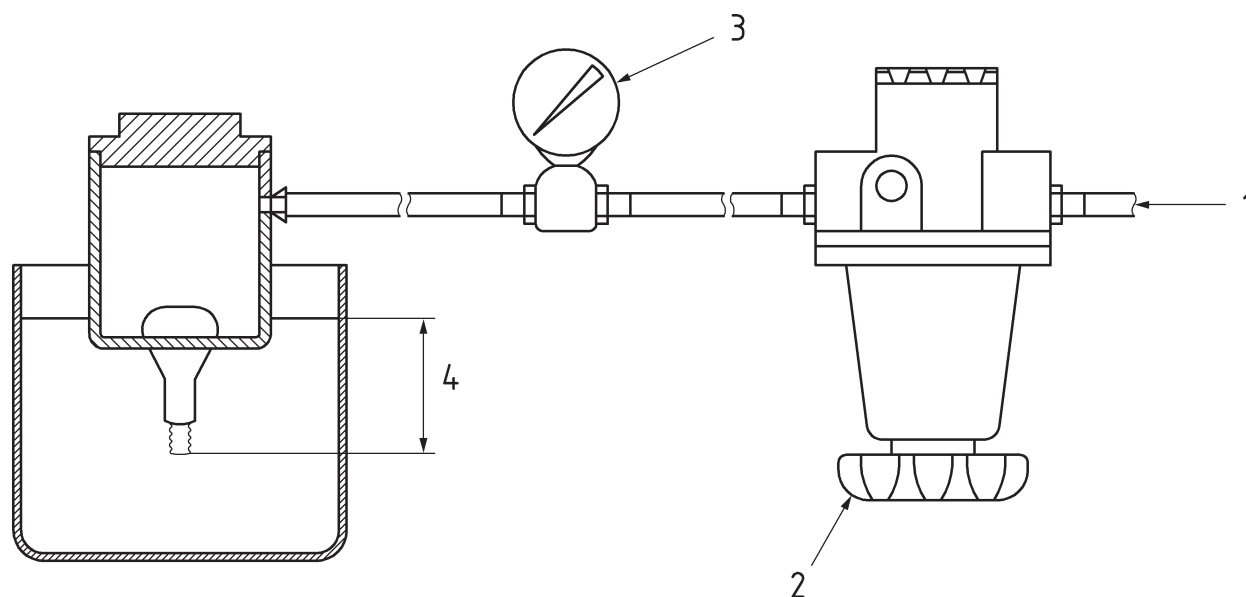

Key

- 1 air supply
- 2 regulator
- 3 gauge
- 4 liquid level (100 mm max)

Figure 1 — Valve seal test description

5.4 Valve to rim seal

Temperature tests are performed to subject the valves to extremes in temperature. Flexing of valves simulates possible operational conditions.

The same valves and assemblies as shown may be used for both tests provided that the low temperature test is conducted first (see [Figure 2](#)).

5.4.1 Low temperature

5.4.1.1 Test holes

- $\text{Ø}11,7 \pm 0/-0,05$, $1,8 \pm 0,05$ thick;
- $\text{Ø}16,1 \pm 0/-0,05$, $1,8 \pm 0,05$ thick.

5.4.1.2 Test methods

- a) Test valves shall be mounted in a test plate as per [4.2](#) and [4.3](#).
- b) Assembly shall then be exposed to a temperature of $-40 \text{ °C} \pm 3 \text{ °C}$ for a minimum of 24 h to ensure that the valve seal area is at the test temperature, and pressure shall be maintained to $180 \text{ kPa} \pm 15 \text{ kPa}$.
- c) The valve assembly, still pressurized to $180 \text{ kPa} \pm 15 \text{ kPa}$, shall then be immersed, valve mouth up, in ethanol or methanol at $-40 \text{ °C} \pm 3 \text{ °C}$, valve button not more than 100 mm below the surface of the liquid.
- d) With respect to the axis of the valve mounting hole, the immersed valve shall be flexed to an angle of $25^\circ \pm 3^\circ$. The cap end of the valve shall then be revolved one complete turn around the axis of the mounting hole. This single revolution shall be executed at a uniform rate without the application of torque to the valve body and accomplished within 15 s to 45 s.

- e) The assembly shall be returned in the refrigerator at $-40\text{ °C} \pm 3\text{ °C}$ after each test, and pressure shall be maintained to $180\text{ kPa} \pm 15\text{ kPa}$.
- f) Repeat points c) to e) at 0,5 h minimum interval period for a total of five times.

5.4.1.3 Performances

Leakage at a rate less than $0,2\text{ cm}^3/\text{min}$ or no bubble detaching during the test time of 1 min is considered acceptable at the rim seal before, during, or after revolving and flexing the valve.

Air inclusions during installation are not considered.

5.4.2 High Temperature

5.4.2.1 Test holes

- $\text{Ø}11,7 \pm 0/-0,05$, $1,8 \pm 0,05$ thick;
- $\text{Ø}16,1 \pm 0/-0,05$, $1,8 \pm 0,05$ thick.

5.4.2.2 Test methods

- a) Test valve shall be mounted in a test plate as per [4.2](#) and [4.3](#).
- b) The test assembly shall then be exposed to a temperature of $100\text{ °C} \pm 3\text{ °C}$ for 48 h in a hot air circulating oven to simulate ageing, and pressure shall be maintained to $600\text{ kPa} \pm 15\text{ kPa}$.
- c) The assembly still pressurized is immersed, valve mouth up, in clean water at $66\text{ °C} \pm 3\text{ °C}$, valve button not more than 100 mm below the surface of the liquid.
- d) With respect to the axis of the valve mounting hole, the immersed valve shall be flexed to an angle of $25^\circ \pm 3^\circ$. The cap end of the valve shall then be revolved one complete turn around the axis of the mounting hole. This single revolution shall be executed at a uniform rate without the application of torque to the valve body and accomplished within 15 s to 45 s. Water temperature shall be maintained at $66\text{ °C} \pm 3\text{ °C}$ during the whole test.
- e) The assembly shall be returned to the hot air oven and pressure shall be maintained to $600\text{ kPa} \pm 15\text{ kPa}$.
- f) Repeat items c) to e) at 0,5 h minimum interval period for a total of five times. The last test shall be performed at the end of the 72 h.

5.4.2.3 Performances

Leakage at a rate less than $0,2\text{ cm}^3/\text{min}$ or no bubble detaching during the test time of 1 min is considered acceptable at the rim seal before, during, or after revolving and flexing the valve.

Air inclusions during installation are not considered.

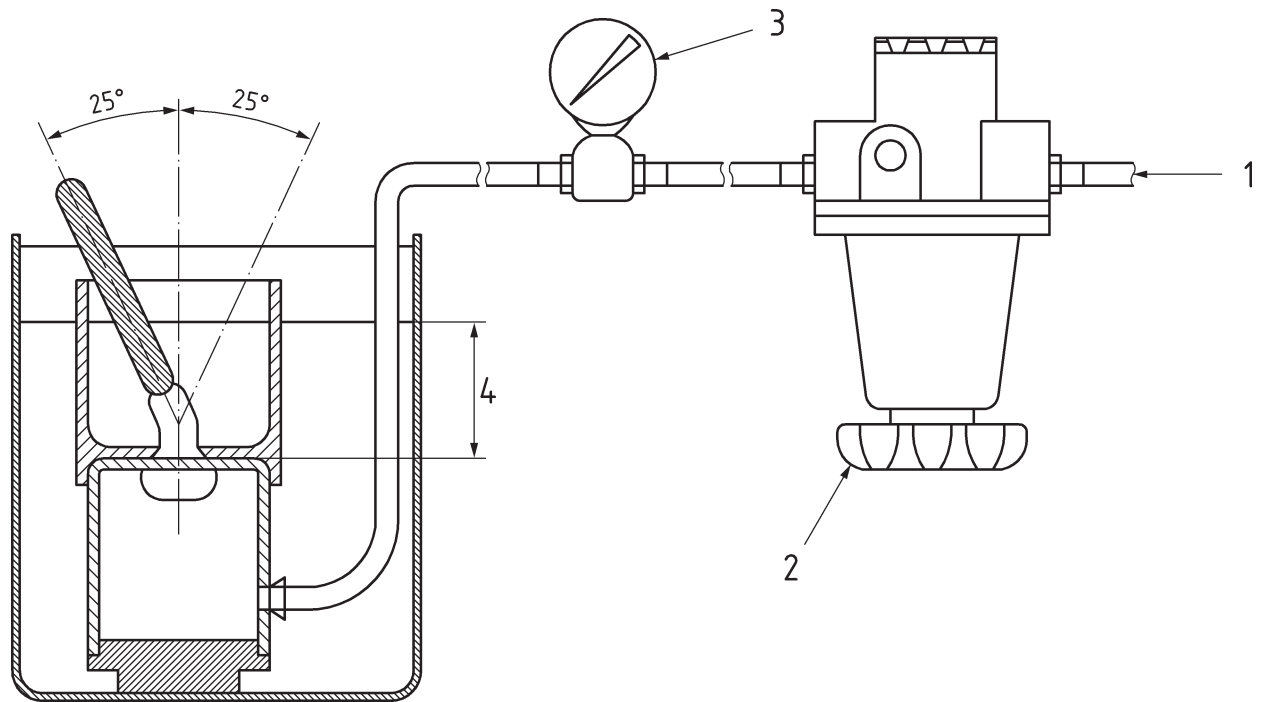

Key

- 1 air supply
- 2 regulator
- 3 gauge
- 4 liquid level (100 mm max)

Figure 2 — Valve to rim seal test description

5.5 Installation tests

5.5.1 Force to seat

5.5.1.1 Test holes

- $\text{Ø}11,3 \pm 0,05$, $3,5 \pm 0,05$ thick;
- $\text{Ø}15,7 \pm 0,05$, $3,5 \pm 0,05$ thick.

5.5.1.2 Test methods

The test valve shall be mounted in a test plate as per [4.2](#) and [4.3](#) at a rate of $150 \text{ mm} \pm 15 \text{ mm}$ per min with a method of measuring the force required.

5.5.1.3 Performances

The force to seat the valve shall be included between 180 N and 450 N.

No tearing or rupturing of the valve is permitted.

5.5.2 Force to pull out

5.5.2.1 Test holes

- $\varnothing 1,3 \pm 0,05$, $3,5 \pm 0,05$ thick;
- $\varnothing 15,7 \pm 0,05$, $3,5 \pm 0,05$ thick.

5.5.2.2 Test methods

- a) The valve is installed as in [5.5.1.2](#).
- b) Additional force shall be applied as in [5.5.1](#) and the force to break the valve or pull out shall be measured.

5.5.2.3 Performances

Minimum force to apply shall be 560 N.

This force is acceptable to break the valve base or to pull the valve out of the hole.

5.6 Burst

5.6.1 Test holes

- $\varnothing 11,7 \pm 0/-0,05$, $1,8 \pm 0,05$ thick;
- $\varnothing 16,1 \pm 0/-0,05$, $1,8 \pm 0,05$ thick.

5.6.2 Test methods

- a) The test valve shall be mounted in a test plate as per [4.2](#) and [4.3](#).
- b) Hydrostatic pressure shall be applied to the valve base to attain a pressure of 1,4 Mpa within 1 min interval.
- c) This test shall be conducted at 20 °C to 26 °C. This maximum pressure shall be maintained for an additional 2 min.

5.6.3 Performances

The valve shall not burst.

5.7 Ozone resistance

5.7.1 Test holes

- $\varnothing 11,3 \pm 0,05/-0$, $3,5 \pm 0,05$ thick;
- $\varnothing 15,7 \pm 0,05/-0$, $3,5 \pm 0,05$ thick.

5.7.2 Test methods

- a) The unmounted valve shall be aged for 72 h at $100 \text{ °C} \pm 3 \text{ °C}$.
- b) The aged valve shall be mounted in a test plate as per [4.2](#) and [4.3](#).
- c) With respect to the axis of the mounting hole, the valve is deflected 10° from its axis and retained in that position for the duration of the test.
- d) The retained valve is placed into a darkened enclosure at 20 °C to 26 °C for a minimum of 24 h.
- e) The valve shall then be tested in an ozone-circulating chamber, maintaining 100 ± 5 parts of ozone to 100 million parts of air for 72 h at $38 \text{ °C} \pm 3 \text{ °C}$.

5.7.3 Performances

The valve rubber shall not exhibit any cracks when viewed with 5x amplification.

5.8 Flexing resistance

5.8.1 Test holes

- 11,7 ±0/-0,05, 1,8 ±0,05 thick;
- 16,1 ±0/-0,05, 1,8 ±0,05 thick.

5.8.2 Test methods

Flexing valves simulates possible operational conditions.

- a) The test valve shall be mounted in a test plate as per 4.2 and 4.3 (see Figure 3).
- b) The valve assembly pressure shall be maintained to 200 kPa and the flexing angle shall be $25^\circ \pm 1^\circ$ from the valve axis. The frequency shall be 2 Hz.

5.8.3 Performances

There shall be no failure after 40,000 cycles.

Failure is defined as a crack visible to the naked eye.

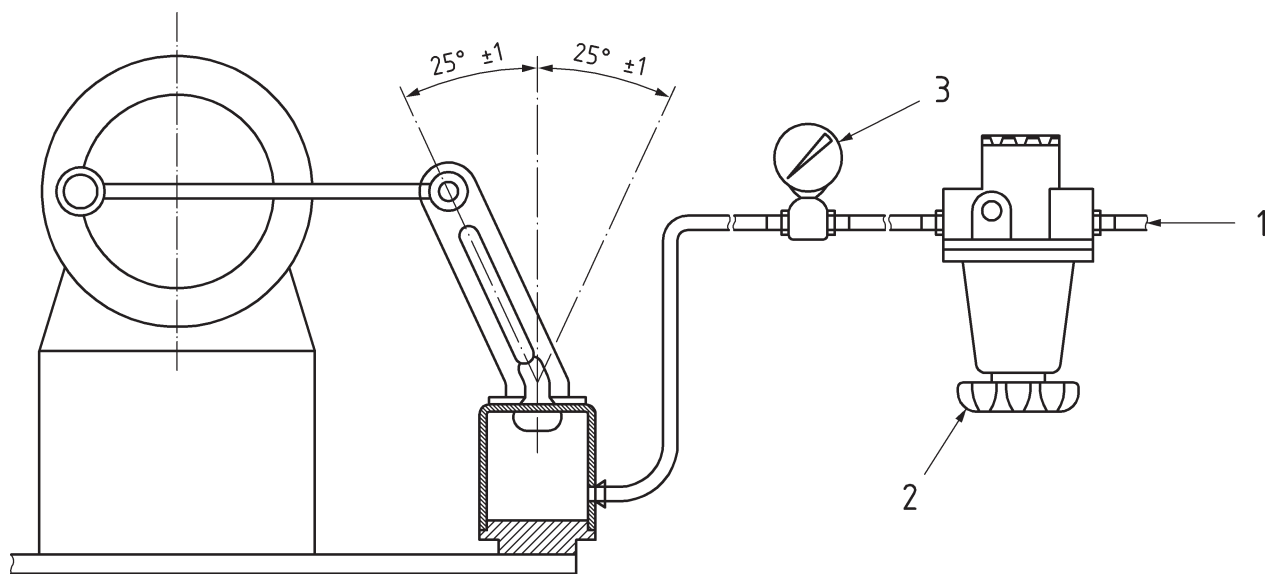

Key

- 1 air supply
- 2 regulator
- 3 gauge

Figure 3 — Flexing resistance test description

Bibliography

- [1] ISO 4000-2, *Passenger car tyres and rims — Part 2: Rims*
- [2] ISO 4209-2, *Truck and bus tyres and rims (metric series) — Part 2: Rims*

British Standards Institution (BSI)

BSI is the national body responsible for preparing British Standards and other standards-related publications, information and services.

BSI is incorporated by Royal Charter. British Standards and other standardization products are published by BSI Standards Limited.

About us

We bring together business, industry, government, consumers, innovators and others to shape their combined experience and expertise into standards-based solutions.

The knowledge embodied in our standards has been carefully assembled in a dependable format and refined through our open consultation process. Organizations of all sizes and across all sectors choose standards to help them achieve their goals.

Information on standards

We can provide you with the knowledge that your organization needs to succeed. Find out more about British Standards by visiting our website at bsigroup.com/standards or contacting our Customer Services team or Knowledge Centre.

Buying standards

You can buy and download PDF versions of BSI publications, including British and adopted European and international standards, through our website at bsigroup.com/shop, where hard copies can also be purchased.

If you need international and foreign standards from other Standards Development Organizations, hard copies can be ordered from our Customer Services team.

Subscriptions

Our range of subscription services are designed to make using standards easier for you. For further information on our subscription products go to bsigroup.com/subscriptions.

With **British Standards Online (BSOL)** you'll have instant access to over 55,000 British and adopted European and international standards from your desktop. It's available 24/7 and is refreshed daily so you'll always be up to date.

You can keep in touch with standards developments and receive substantial discounts on the purchase price of standards, both in single copy and subscription format, by becoming a **BSI Subscribing Member**.

PLUS is an updating service exclusive to BSI Subscribing Members. You will automatically receive the latest hard copy of your standards when they're revised or replaced.

To find out more about becoming a BSI Subscribing Member and the benefits of membership, please visit bsigroup.com/shop.

With a **Multi-User Network Licence (MUNL)** you are able to host standards publications on your intranet. Licences can cover as few or as many users as you wish. With updates supplied as soon as they're available, you can be sure your documentation is current. For further information, email bsmusales@bsigroup.com.

BSI Group Headquarters

389 Chiswick High Road London W4 4AL UK

Revisions

Our British Standards and other publications are updated by amendment or revision.

We continually improve the quality of our products and services to benefit your business. If you find an inaccuracy or ambiguity within a British Standard or other BSI publication please inform the Knowledge Centre.

Copyright

All the data, software and documentation set out in all British Standards and other BSI publications are the property of and copyrighted by BSI, or some person or entity that owns copyright in the information used (such as the international standardization bodies) and has formally licensed such information to BSI for commercial publication and use. Except as permitted under the Copyright, Designs and Patents Act 1988 no extract may be reproduced, stored in a retrieval system or transmitted in any form or by any means – electronic, photocopying, recording or otherwise – without prior written permission from BSI. Details and advice can be obtained from the Copyright & Licensing Department.

Useful Contacts:

Customer Services

Tel: +44 845 086 9001

Email (orders): orders@bsigroup.com

Email (enquiries): cservices@bsigroup.com

Subscriptions

Tel: +44 845 086 9001

Email: subscriptions@bsigroup.com

Knowledge Centre

Tel: +44 20 8996 7004

Email: knowledgecentre@bsigroup.com

Copyright & Licensing

Tel: +44 20 8996 7070

Email: copyright@bsigroup.com



...making excellence a habit.™