



BSI Standards Publication

Fine ceramics (advanced ceramics, advanced technical ceramics) — Methods of test for ceramic coatings — Determination of fracture strain

National foreword

This British Standard is the UK implementation of ISO 14604:2012.

The UK participation in its preparation was entrusted to Technical Committee RPI/13, Advanced technical ceramics.

A list of organizations represented on this committee can be obtained on request to its secretary.

This publication does not purport to include all the necessary provisions of a contract. Users are responsible for its correct application.

© The British Standards Institution 2012. Published by BSI Standards Limited 2012

ISBN 978 0 580 69620 6

ICS 81.060.30

Compliance with a British Standard cannot confer immunity from legal obligations.

This British Standard was published under the authority of the Standards Policy and Strategy Committee on 31 December 2012.

Amendments issued since publication

Date	Text affected
------	---------------

INTERNATIONAL
STANDARD

ISO
14604

First edition
2012-12-01

**Fine ceramics (advanced ceramics,
advanced technical ceramics) —
Methods of test for ceramic coatings —
Determination of fracture strain**

*Céramiques techniques — Méthodes d'essai des revêtements
céramiques — Détermination de la déformation à la rupture*



Reference number
ISO 14604:2012(E)

© ISO 2012



COPYRIGHT PROTECTED DOCUMENT

© ISO 2012

All rights reserved. Unless otherwise specified, no part of this publication may be reproduced or utilized in any form or by any means, electronic or mechanical, including photocopying and microfilm, without permission in writing from either ISO at the address below or ISO's member body in the country of the requester.

ISO copyright office
Case postale 56 • CH-1211 Geneva 20
Tel. + 41 22 749 01 11
Fax + 41 22 749 09 47
E-mail copyright@iso.org
Web www.iso.org

Published in Switzerland

Contents

Page

Foreword	iv
Introduction	v
1 Scope	1
2 Normative references	1
3 Terms and definitions	1
4 Significance and use	2
5 Principle	2
6 Apparatus and materials	2
6.1 Instrumentation.....	2
6.2 Specimen preparation.....	3
7 Test procedure	4
7.1 Calibration.....	4
7.2 Sample loading.....	4
7.3 Strain determination.....	4
7.4 Crack detection.....	5
7.5 Test parameters.....	6
8 Test report	6
Bibliography	11

Foreword

ISO (the International Organization for Standardization) is a worldwide federation of national standards bodies (ISO member bodies). The work of preparing International Standards is normally carried out through ISO technical committees. Each member body interested in a subject for which a technical committee has been established has the right to be represented on that committee. International organizations, governmental and non-governmental, in liaison with ISO, also take part in the work. ISO collaborates closely with the International Electrotechnical Commission (IEC) on all matters of electrotechnical standardization.

International Standards are drafted in accordance with the rules given in the ISO/IEC Directives, Part 2.

The main task of technical committees is to prepare International Standards. Draft International Standards adopted by the technical committees are circulated to the member bodies for voting. Publication as an International Standard requires approval by at least 75 % of the member bodies casting a vote.

Attention is drawn to the possibility that some of the elements of this document may be the subject of patent rights. ISO shall not be held responsible for identifying any or all such patent rights.

ISO 14604 was prepared by Technical Committee ISO/TC 206, *Fine ceramics*.

Introduction

The fracture strain of a coating is a critical factor often determining the performance of a coated product. Clearly, if stressed either directly or due to thermal effects (thermal expansion coefficient mismatch between the coating and substrate) coating cracking can occur if the critical fracture stress/strain is exceeded, and in many cases the effectiveness of the coating will be reduced. For example, corrosion-resistant coatings lose their protective character if cracking occurs, and optical coatings become ineffective when cracked. In many cases, cracking is the first stage of a much more serious form of failure in which large areas of the coating can spall.

This International Standard describes a method for the determination of fracture strain using a technique of applying stresses to a coupon of material by a uniaxial tensile or compressive test or a beam bending test where the initiation of fracture in the coating is determined using an acoustic emission method.

The extent to which coated components can withstand external applied loads is an important property in the application of any coated system, and usually the failure stress is required. For calculation of the stress, both the fracture strain and Young's modulus of the coating should be known. ISO 14577-4:2007^[1] can be used to measure Young's modulus by depth-sensing indentation, but there are other methods involving flexure and impact excitation that may also be applied (References [2], [3]).

Fine ceramics (advanced ceramics, advanced technical ceramics) — Methods of test for ceramic coatings — Determination of fracture strain

1 Scope

This International Standard describes a method of measuring the fracture strain of ceramic coatings by means of uniaxial tension or compression tests coupled with acoustic emission to monitor the onset of cracking of the coating. Tensile or compressive strains can also be applied by flexure using four-point bending. Measurements can be made in favourable cases at elevated temperatures as well as at room temperature.

2 Normative references

The following referenced documents are indispensable for the application of this document. For dated references, only the edition cited applies. For undated references, the latest edition of the referenced document (including any amendments) applies.

EN 10002-1, *Metallic materials — Tensile testing — Part 1: Method of test at ambient temperature*

EN 10002-5, *Metallic materials — Tensile testing — Part 5: Method of test at elevated temperature*

ISO 12106, *Metallic materials — Fatigue testing — Axial-strain-controlled method*

3 Terms and definitions

For the purposes of this document, the following terms and definitions apply.

3.1

fracture strain

strain required to create a detectable crack in the coating

NOTE The presence of the crack can be detected using optical or scanning electron microscopy, or indirectly using acoustic emission

3.2

acoustic emission

AE

generation of acoustic signals

NOTE See Figure 1 for definition of AE signals. AE signals are recorded as hits, counts, energy or amplitude (3.3, 3.4, 3.5 and 3.6).

3.3

AE hit

single acoustic event above a set threshold

3.4

AE energy

area of the waveform of an AE hit

3.5

AE amplitude

peak of the waveform of an AE hit

3.6

AE threshold

arbitrary AE amplitude at which AE hits are deemed to be significant and above the AE signals generated by the test equipment

3.7

AE counts

number of times the AE waveform passes a set threshold within a single hit

3.8

waveguide

metallic wire connecting (usually by spot welding) the sample to the AE transducer

4 Significance and use

This test procedure covers the measurement of fracture strain in tension or compression in coatings subject to mechanical stress at ambient or elevated temperature.

The method is applicable to cases where the substrate is sufficiently ductile such that fracture of the coating occurs before the substrate. In addition, if during plastic deformation of the substrate acoustic signals are generated, this may interfere with those caused by coating fracture. Where possible, it is recommended that a test be carried out with the uncoated substrate to determine whether such extraneous AE signals occur.

5 Principle

Specimens of appropriate geometry are submitted to a mechanical stress; the subsequent strain is measured and the onset of coating failure is detected. The test draws upon the expertise of standard tensile and compressive tests but requires additional care due to the precision required of the measurements. The applied stress may be tensile or compressive and may be applied directly or in flexure. The test shall be carried out to satisfy the requirements of accepted standards for mechanical testing of materials under the selected method of loading.

NOTE 1 Detection of the fracture of coatings can be carried out in a number of ways. The most convenient is to use acoustic emission (AE), which allows continuous monitoring of the specimen. Acoustic signals are produced when a crack forms. These signals are captured using suitable detectors and the signals generated are then analysed. In many cases, a waveguide is used to carry the signal from the specimen to the detector; this waveguide is normally a metallic material. Use of two AE detectors can help to eliminate extraneous signals coming from the loading mechanism. Commercially available AE systems can be used for this work.

NOTE 2 Where AE cannot be used, crack detection is possible by high-resolution video systems, which may allow continuous monitoring. Alternatively, optical or scanning electron microscopy can be used to examine the samples. Normally this is done post-test, but *in situ* examination is also possible.

6 Apparatus and materials

6.1 Instrumentation

6.1.1 In simplest terms, the equipment required is a mechanism to apply load to the specimen; extensometry to measure the strain; and apparatus to detect/monitor fracture of the surface layer. Load is normally applied continuously through servo-electric testing machines; the load capacity of the frame should be sufficient to allow straining of the specimen to beyond the yield point of the substrate material. Continuation of the test to complete separation of the specimen is not normally required.

6.1.2 For flexural testing, a suitable test jig is required; four-point bending is recommended as this applies more uniform bending moment over the gauge length. A suitable jig is shown in Figure 2.

6.1.3 Extensometry should be sufficiently precise to measure strain at a resolution of 0,01 %.

6.1.4 For tests at high temperatures using the uniaxial test configuration, a furnace is required which allows access for attachment of load frame, together with extensometry, thermocouples and waveguides to transmit the AE signals to the AE detector(s). For the four-point bend configuration, an oxidation-resistant jig shall be used.

NOTE Deformation of oxide layers formed on a metallic jig will probably contribute to AE signals during the test.

6.1.5 Crack detection in the coating may be performed visually or by monitoring AE. Visual inspection requires suitable long-focal-length video facilities with a field of view containing the gauge length. At high temperatures, the availability of a cool path to the video camera is also required to avoid shimmer of the image.

6.2 Specimen preparation

6.2.1 Standard specimens shall be used as appropriate for the uniaxial or flexure test configurations; for uniaxial tensile tests the specimen shapes are defined in EN 10002-1, for compression tests in ISO 12106 and, for flexure, simple bar-shaped samples of appropriate thickness can be used. The coating may be deposited on to the sample after machining to the required shape, or in the case of flat specimens, the test piece can be machined from the coated material. In the latter case, care shall be taken to avoid damage to the test region that may cause premature fracture. Generally, the surface of the coating should not be ground or polished except where there is a requirement to do so.

6.2.2 The strain that is measured using this technique represents a summation of the inherent fracture strain of the surface layer and the residual strain present at the test temperature. For a sample with a residual compressive strain, the measured tensile strain is the sum of the coating fracture strain and the residual compressive strain, and vice versa for a sample with residual tensile strain. For most purposes, it is the inherent fracture strain that is required, therefore, it is recommended that the residual strain in the coating be measured at the test temperature by an appropriate technique, e.g. X-ray diffraction for crystalline materials or the Stoney bend test for amorphous materials. This may be carried out on each test specimen but it is normally sufficient to measure only one specimen under each coating condition.

6.2.3 Specimens for testing under flexural loading with AE detection require that the coating is removed from one face in order to avoid AE detection of failure events from both tension and compression. In addition, it is also recommended that coating be removed from the region where contact is made in the test jig. This precaution reduces the amount of extraneous signal arising from local fracture of coating under high point loading. For testing at elevated temperatures, it is also recommended that the specimen be coated with a corrosion-resistant coating that is acoustically quiet (suitable proprietary coatings are readily available). Where the material does not have sufficient oxidation resistance, consideration shall be given to carrying out the tests in an inert environment, since the oxide layers that would form could also crack and hence contribute to the AE signals. Care shall be taken to ensure that the sample has attained the test temperature before commencing the test.

6.2.4 Specimens for tests under flexural loading shall be simple beams with dimensions suitable for the test jig. Typical specimens are 50 mm x 5 mm x 2 mm, but the dimensions are dependent upon the strength of the material at the test temperature.

NOTE Care should be taken to ensure that the specimens have sufficient thickness that uniform straining is achieved; the onset of localized deformation around the rollers is material, thickness and temperature dependent; the specimen design for each material of interest should therefore be reviewed prior to starting the measurement programme.

6.2.5 Specimens for testing under direct tensile loading may be planar or of circular cross-section. The choice is governed mainly by the form of material available, as both specimen types have advantages and disadvantages, with neither geometry showing sufficient superiority over the other to present a definitive

case for its use. In both cases care should be taken to minimize the introduction of stress concentrations that would induce early failure of the coating.

6.2.6 For testing under direct compression, specimens with circular gauge cross-section shall be used according to ISO 12106. Care shall be taken in the choice of gauge length and cross-section to avoid buckling and bulging of the specimen during compressive loading.

6.2.7 Replicate tests shall be carried out, and at least five are required.

NOTE Coating fracture is well described by fracture mechanics in which defect size and distribution control the behaviour. Thus, to obtain a statistically valid result replicate testing is essential. It is recommended that 10 samples should be tested, but it is recognized that this many samples may not always be available.

6.2.8 The coating/substrate specific parameters include:

- a) coating thickness;
- b) residual stress.

These parameters shall be kept constant if a direct comparison is made between two or more test pieces unless corrections are applied to normalize the data.

7 Test procedure

7.1 Calibration

The instrument shall be calibrated according to the procedures set out in the appropriate standard. Ensure that all systems are operating correctly, and introduce the test piece after appropriate preparation as detailed in 6.2.

7.2 Sample loading

The application of load may be performed under load, displacement or strain control. The rate of loading is not critical but should conform to the rates specified for tensile testing of metals at ambient (see EN 10002-1) or elevated temperatures (see EN 10002-5). Load shall be applied smoothly in order to avoid impact loading of the coating that may cause premature cracking. The loading mechanism shall also ensure that bending stresses due, for example, to twisting of a flexural beam or by misalignment of uniaxial specimens, are not introduced.

7.3 Strain determination

In four-point flexure, strain, ε , is calculated from the dimensions of the test jig and the relative displacement of the upper and lower rollers according to the following expression:

$$\varepsilon = \frac{3\delta d}{u(3s - 4u)} \quad (1)$$

where

- δ is the relative displacement between the upper and lower rollers, in millimetres, when the sample is bent;
- d is the test piece thickness, in millimetres;
- u is the distance between outer and inner rollers, in millimetres;
- s is the spacing of the outer rollers, in millimetres.

NOTE 1 This expression is valid for strains of < 0,3 % (Reference [4]). The spacing of the rollers is fixed and therefore does not vary from test to test; the thickness of the specimen is measured by a micrometer to an accuracy of 0,01 mm; the relative displacement of the upper and lower rollers is measured by a transducer and an accuracy of 0,01 mm can readily be achieved. This leads to a repeatability for the measurement of approximately 1,5 % of the value and a reproducibility of 8 % if the difference in roller spacing between test jigs is 0,5 mm.

NOTE 2 To achieve the same repeatability in direct loading, extensometry should be used that will provide an uncertainty of < 1,5 % of the measured strain at the strain level of coating fracture. This can be achieved by extensometry of grade 0,2 as described in ISO 9513 [6] when the gauge length of the specimen exceeds 2,7 mm. A grade 0,5 extensometer requires a minimum gauge length of 6,8 mm.

7.4 Crack detection

7.4.1 Continuous monitoring of the AE from the specimen under test may provide enough information to determine the onset of coating cracking in many cases, but care shall always be taken to ensure that the signals detected originate from cracking events and not from other sources. The use of a two-sensor system with position-location software is strongly recommended to identify the AE signals coming from within the gauge length of the specimen. A sample of the uncoated substrate material shall be tested in order to determine if any AE originates within the bulk material at strains similar to the fracture strain of the coating. If this proves to be the case then AE cannot be used as a reliable detection method for coating cracking. This test shall be used to set the AE threshold parameters to be used during the test with the coated sample.

NOTE 1 AE signals usually show the behaviour illustrated in Figures 3 and 4 and require careful interpretation to derive the failure strain of the coating. This failure strain can be defined by the back extrapolation of the region where the number of events is rising rapidly with strain. The tangent to the point of inflection on the cumulative AE plot is often used (Figure 4).

NOTE 2 Events occurring before this region can be attributed to cracking events that do not propagate through the entire thickness of the coating or to general 'noise' in the system. Events occurring in the upper plateau of the trace are attributed to repeated cracking of the coating leading to a decrease in crack spacing.

Other methods of determining the onset of coating fracture from the AE signals can be used. The first signal above the AE threshold level is also valid and, as can be seen from Figure 3, discrimination is good in this case. The method used should be optimised for the system under investigation. Also, in certain cases, particularly for very brittle coatings, the occurrence of a high AE energy can be a good indication of coating cracking.

7.4.2 Visual inspection of the specimens during the test is an alternative to AE. Video equipment with long focal length is available to enable direct observation during the test. Problems may be encountered during flexural loading but these can be overcome by the use of fibre optics and suitable jig design.

7.4.3 An alternative technique for room-temperature testing is to periodically produce a plastic replica of the specimen surface for subsequent examination using scanning electron microscopy (Reference [5]). This method only gives intermittent strain monitoring.

7.5 Test parameters

The specific test parameters include:

- a) loading rate;
- b) applied load;
- c) displacement;
- d) time;
- e) strain at onset of fracture;
- f) AE threshold, if used;
- g) strain at onset of AE, if used;
- h) sample dimensions;
- i) four-point bending jig inner and outer roller spacing, if used.

All the above parameters shall be kept constant if a direct comparison is made between two or more test pieces unless corrections are applied to normalize the data.

8 Test report

The report of the measurement should contain as a minimum the following information:

- a) the name of the testing establishment;
- b) the date of the test, unique identification of the report and of each page, the name and address of the customer, and the signatory of the report;
- c) a reference to this method, i.e. determined in accordance with ISO 14604;
- d) a description of the test machine employed;
- e) method of crack detection and, if AE is used, the criterion for onset of cracking;
- f) details of the checks carried out on the test machine including calibration;
- g) details of the test material type, manufacturing code, batch number, etc.;
- h) coating parameters for the test specimens, if known;
- i) coating thickness;
- j) details of the preparation of the surface and sample geometry;
- k) strain rate;
- l) individual test results, the arithmetic mean results and the standard deviation;
- m) comments on the test results and methodology, particularly noting departures from this method.

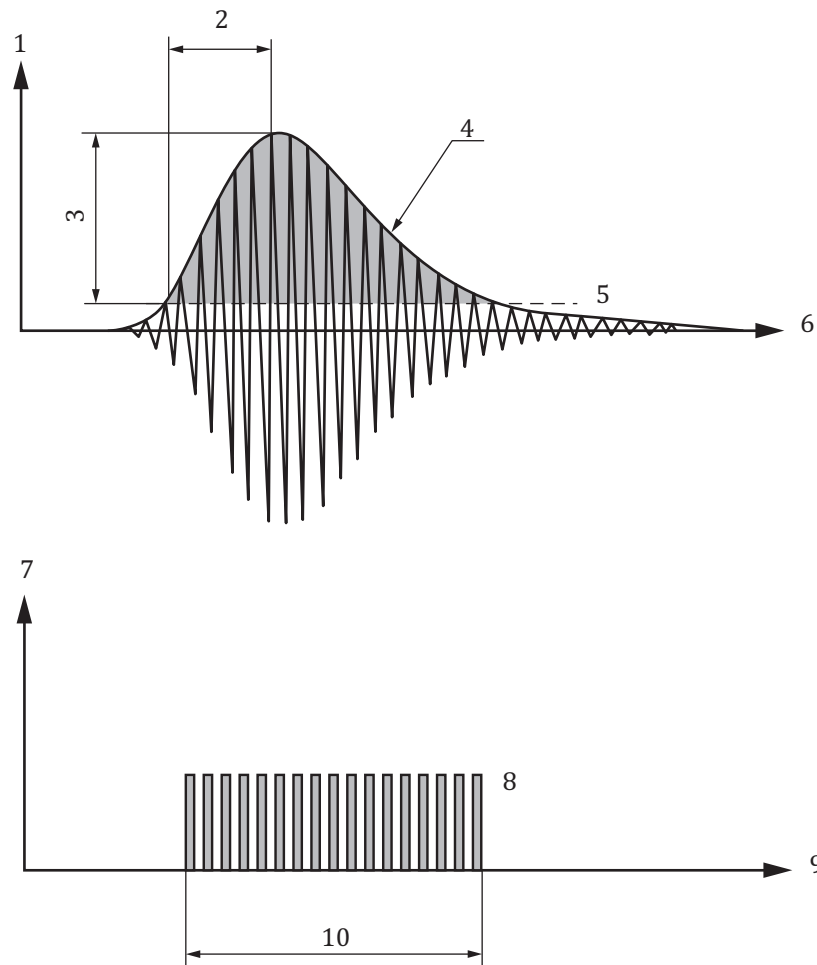

Key

- | | | | |
|---|-----------|----|--------------------|
| 1 | Volts | 6 | Time |
| 2 | Rise time | 7 | Threshold crossing |
| 3 | Amplitude | 8 | Counts |
| 4 | Energy | 9 | Time |
| 5 | Threshold | 10 | Duration |

Figure 1 — Schematic representation of AE signals

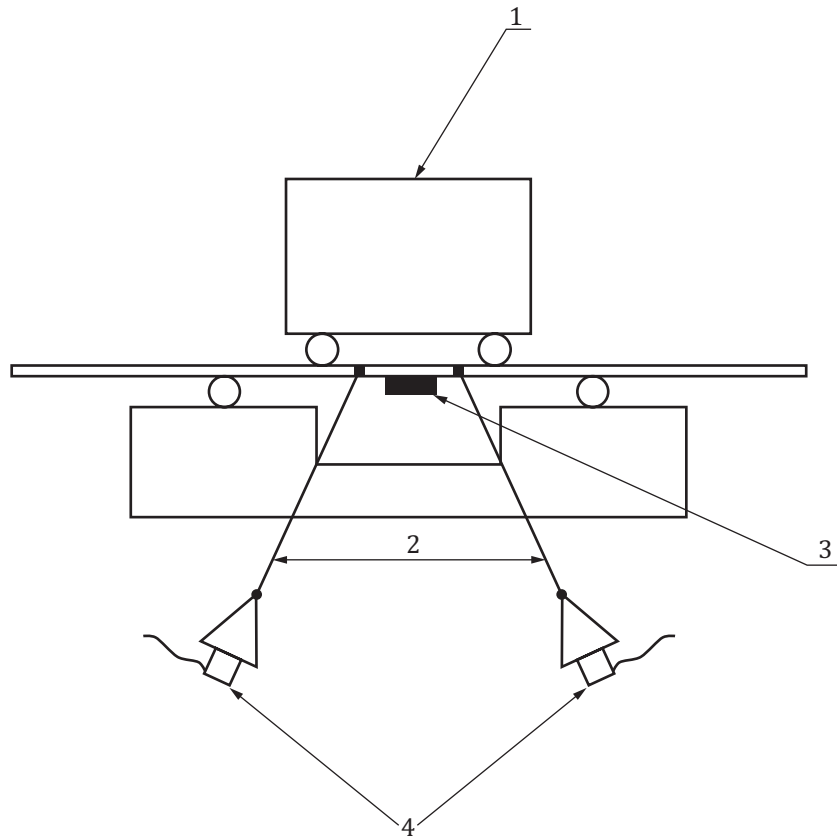

Key

- 1 Load
- 2 Waveguides
- 3 Coating
- 4 AE detectors

Figure 2 — Schematic diagram of a flexural jig with acoustic emission sensors

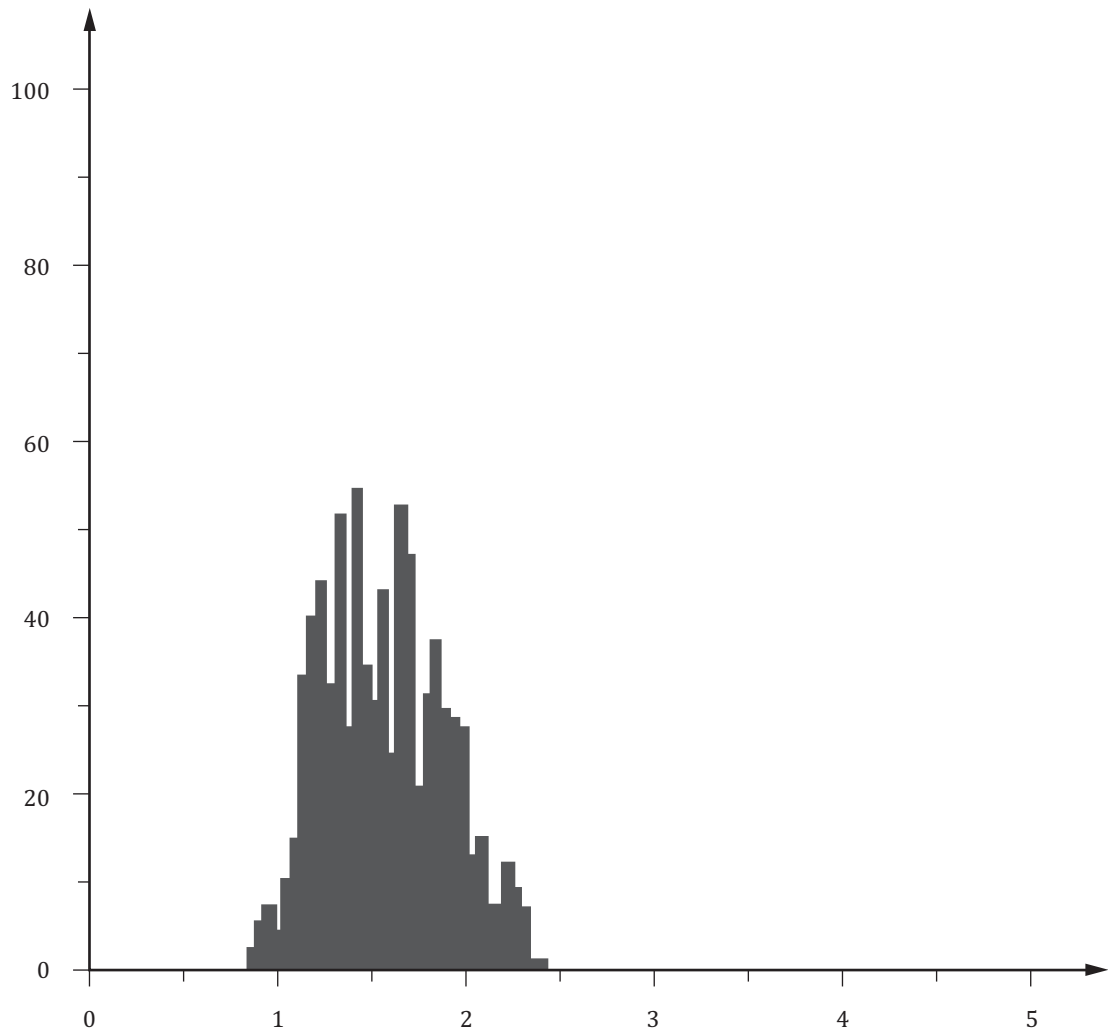
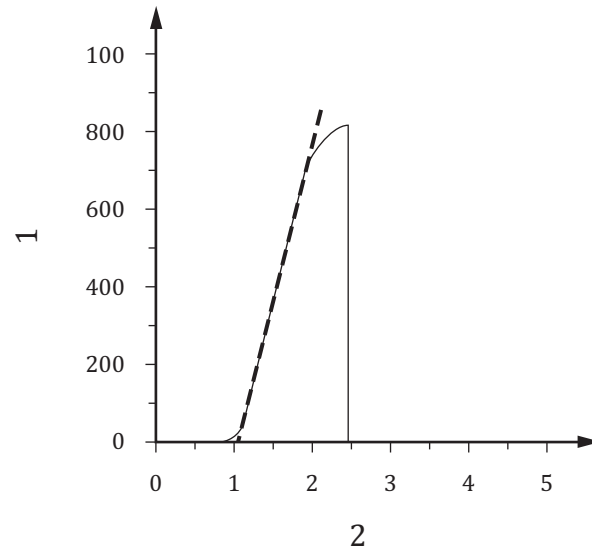

Figure 3 — AE hits versus strain during tensile tests of a coating showing onset of coating fracture at about 0,9 % strain



Key

- 1 AE hits
- 2 Strain, %

Figure 4 — Analysis procedure for acoustic emission signals

Bibliography

- [1] ISO 14577-4:2007, *Metallic materials — Instrumented indentation test for hardness and materials parameters — Part 4: Test method for metallic and non-metallic coatings*
- [2] HARRY E., ROUZAUD A., INGAT M., JULIET P. *Thin Solid Films*. 1998, **332**, pp. 195–201
- [3] MOUSSU F., & NIVOIT M. J. *Sound Vib.*, 165 (1993) pp.149-163
- [4] NAGL M.M., SAUNDERS S.R.J., GUTTMAN V. *Materials at High Temperature*. 1994, **12**, pp. 163–168
- [5] STRANGMAN T.E. *Thermal Fatigue of Oxidation Resistant Coatings for Superalloys*, PhD Thesis, University of Connecticut, 1978
- [6] ISO 9513, *Metallic materials — Calibration of extensometer systems used in uniaxial testing*

British Standards Institution (BSI)

BSI is the national body responsible for preparing British Standards and other standards-related publications, information and services.

BSI is incorporated by Royal Charter. British Standards and other standardization products are published by BSI Standards Limited.

About us

We bring together business, industry, government, consumers, innovators and others to shape their combined experience and expertise into standards-based solutions.

The knowledge embodied in our standards has been carefully assembled in a dependable format and refined through our open consultation process. Organizations of all sizes and across all sectors choose standards to help them achieve their goals.

Information on standards

We can provide you with the knowledge that your organization needs to succeed. Find out more about British Standards by visiting our website at bsigroup.com/standards or contacting our Customer Services team or Knowledge Centre.

Buying standards

You can buy and download PDF versions of BSI publications, including British and adopted European and international standards, through our website at bsigroup.com/shop, where hard copies can also be purchased.

If you need international and foreign standards from other Standards Development Organizations, hard copies can be ordered from our Customer Services team.

Subscriptions

Our range of subscription services are designed to make using standards easier for you. For further information on our subscription products go to bsigroup.com/subscriptions.

With **British Standards Online (BSOL)** you'll have instant access to over 55,000 British and adopted European and international standards from your desktop. It's available 24/7 and is refreshed daily so you'll always be up to date.

You can keep in touch with standards developments and receive substantial discounts on the purchase price of standards, both in single copy and subscription format, by becoming a **BSI Subscribing Member**.

PLUS is an updating service exclusive to BSI Subscribing Members. You will automatically receive the latest hard copy of your standards when they're revised or replaced.

To find out more about becoming a BSI Subscribing Member and the benefits of membership, please visit bsigroup.com/shop.

With a **Multi-User Network Licence (MUNL)** you are able to host standards publications on your intranet. Licences can cover as few or as many users as you wish. With updates supplied as soon as they're available, you can be sure your documentation is current. For further information, email bsmusales@bsigroup.com.

BSI Group Headquarters

389 Chiswick High Road London W4 4AL UK

Revisions

Our British Standards and other publications are updated by amendment or revision.

We continually improve the quality of our products and services to benefit your business. If you find an inaccuracy or ambiguity within a British Standard or other BSI publication please inform the Knowledge Centre.

Copyright

All the data, software and documentation set out in all British Standards and other BSI publications are the property of and copyrighted by BSI, or some person or entity that owns copyright in the information used (such as the international standardization bodies) and has formally licensed such information to BSI for commercial publication and use. Except as permitted under the Copyright, Designs and Patents Act 1988 no extract may be reproduced, stored in a retrieval system or transmitted in any form or by any means – electronic, photocopying, recording or otherwise – without prior written permission from BSI. Details and advice can be obtained from the Copyright & Licensing Department.

Useful Contacts:

Customer Services

Tel: +44 845 086 9001

Email (orders): orders@bsigroup.com

Email (enquiries): cservices@bsigroup.com

Subscriptions

Tel: +44 845 086 9001

Email: subscriptions@bsigroup.com

Knowledge Centre

Tel: +44 20 8996 7004

Email: knowledgecentre@bsigroup.com

Copyright & Licensing

Tel: +44 20 8996 7070

Email: copyright@bsigroup.com



...making excellence a habit.™