

BS ISO 14540:2013



BSI Standards Publication

**Hydraulic fluid power —  
Dimensions and requirements  
for screw-to-connect quick-  
action couplings for use at a  
pressure of 72 MPa (720 bar)**

**bsi.**

...making excellence a habit.™

**National foreword**

This British Standard is the UK implementation of ISO 14540:2013.

The UK participation in its preparation was entrusted to Technical Committee MCE/18/-/4, Connectors and associated components.

A list of organizations represented on this committee can be obtained on request to its secretary.

This publication does not purport to include all the necessary provisions of a contract. Users are responsible for its correct application.

© The British Standards Institution 2013.  
Published by BSI Standards Limited 2013.

ISBN 978 0 580 73940 8

ICS 23.100.40

**Compliance with a British Standard cannot confer immunity from legal obligations.**

This British Standard was published under the authority of the Standards Policy and Strategy Committee on 30 April 2013.

**Amendments issued since publication**

Date	Text affected
------	---------------

---

---

---

**Hydraulic fluid power — Dimensions  
and requirements for screw-to-  
connect quick-action couplings for use  
at a pressure of 72 MPa (720 bar)**

*Transmissions hydrauliques — Dimensions et exigences des raccords  
rapides de type à visser pour usage à une pression de 72 MPa (720 bar)*





**COPYRIGHT PROTECTED DOCUMENT**

© ISO 2013

All rights reserved. Unless otherwise specified, no part of this publication may be reproduced or utilized otherwise in any form or by any means, electronic or mechanical, including photocopying, or posting on the internet or an intranet, without prior written permission. Permission can be requested from either ISO at the address below or ISO's member body in the country of the requester.

ISO copyright office  
Case postale 56 • CH-1211 Geneva 20  
Tel. + 41 22 749 01 11  
Fax + 41 22 749 09 47  
E-mail [copyright@iso.org](mailto:copyright@iso.org)  
Web [www.iso.org](http://www.iso.org)

Published in Switzerland

<b>Contents</b>		Page
<b>Foreword</b> .....		<b>iv</b>
<b>Introduction</b> .....		<b>v</b>
<b>1 Scope</b> .....		<b>1</b>
<b>2 Normative references</b> .....		<b>1</b>
<b>3 Terms and definitions</b> .....		<b>1</b>
<b>4 Dimensional requirements</b> .....		<b>1</b>
<b>5 Performance requirements</b> .....		<b>3</b>
<b>6 Best practice</b> .....		<b>3</b>
<b>7 Designation</b> .....		<b>4</b>
<b>8 Marking</b> .....		<b>4</b>
<b>9 Identification statement</b> (reference to this International Standard) .....		<b>4</b>
<b>Annex A</b> (normative) <b>Basic dimensions of the 1-18 UNS inch screw thread</b> .....		<b>5</b>
<b>Bibliography</b> .....		<b>6</b>

## Foreword

ISO (the International Organization for Standardization) is a worldwide federation of national standards bodies (ISO member bodies). The work of preparing International Standards is normally carried out through ISO technical committees. Each member body interested in a subject for which a technical committee has been established has the right to be represented on that committee. International organizations, governmental and non-governmental, in liaison with ISO, also take part in the work. ISO collaborates closely with the International Electrotechnical Commission (IEC) on all matters of electrotechnical standardization.

The procedures used to develop this document and those intended for its further maintenance are described in the ISO/IEC Directives, Part 1. In particular the different approval criteria needed for the different types of ISO documents should be noted. This document was drafted in accordance with the editorial rules of the ISO/IEC Directives, Part 2. [www.iso.org/directives](http://www.iso.org/directives)

Attention is drawn to the possibility that some of the elements of this document may be the subject of patent rights. ISO shall not be held responsible for identifying any or all such patent rights. Details of any patent rights identified during the development of the document will be in the Introduction and/or on the ISO list of patent declarations received. [www.iso.org/patents](http://www.iso.org/patents)

Any trade name used in this document is information given for the convenience of users and does not constitute an endorsement.

The committee responsible for this document is ISO/TC 131, *Fluid power systems*, Subcommittee SC 4, *Connectors and similar products and components*.

## Introduction

In hydraulic fluid power systems, power is transmitted and controlled through a liquid under pressure within an enclosed circuit.

Screw-to-connect quick-action couplings conforming to this International Standard are designed to join or separate fluid conductors ensuring, at the same time, sufficient resistance and safety in applications characterized by very high working pressures up to 72 MPa (720 bar).





# Hydraulic fluid power — Dimensions and requirements for screw-to-connect quick-action couplings for use at a pressure of 72 MPa (720 bar)

## 1 Scope

This International Standard specifies dimensional and performance requirements for hydraulic screw-to-connect quick-action couplings designed to be used at pressure of 72 MPa (720 bar<sup>1</sup>) in static conditions as an interface between a hydraulic power unit and a tool. Typical applications for these couplings are related to hydraulic jacks, rams, clamping devices, hand tools, and cylinders.

This International Standard covers two types of such couplings: the “P” type, which has a poppet valve, and the “S” type, which has a spherical valve.

## 2 Normative references

The following documents, in whole or in part, are normatively referenced in this document and are indispensable for its application. For dated references, only the edition cited applies. For undated references, the latest edition of the referenced document (including amendments) applies.

ISO 725, *ISO inch screw threads — Basic dimensions*

ISO 5598, *Fluid power systems and components — Vocabulary*

ISO 5864, *ISO inch screw threads — Allowances and tolerances*

ISO 7241-2, *Hydraulic fluid power — Quick-action couplings — Part 2: Test methods*

## 3 Terms and definitions

For the purposes of this document, the terms and definitions given in ISO 5598 and the following apply.

### 3.1

#### **fluid loss**

fluid that exits the coupling when it is disconnected

### 3.2

#### **residual static pressure**

static pressure remaining in the circuit without flow

## 4 Dimensional requirements

Couplings shall conform to the dimensions shown in [Figure 1](#) and given in [Table 1](#).

---

1) 1 bar = 100 kPa = 10<sup>5</sup> Pa = 0,1 MPa; 1 Pa = 1 N/m<sup>2</sup>

Surface roughness values in micrometres

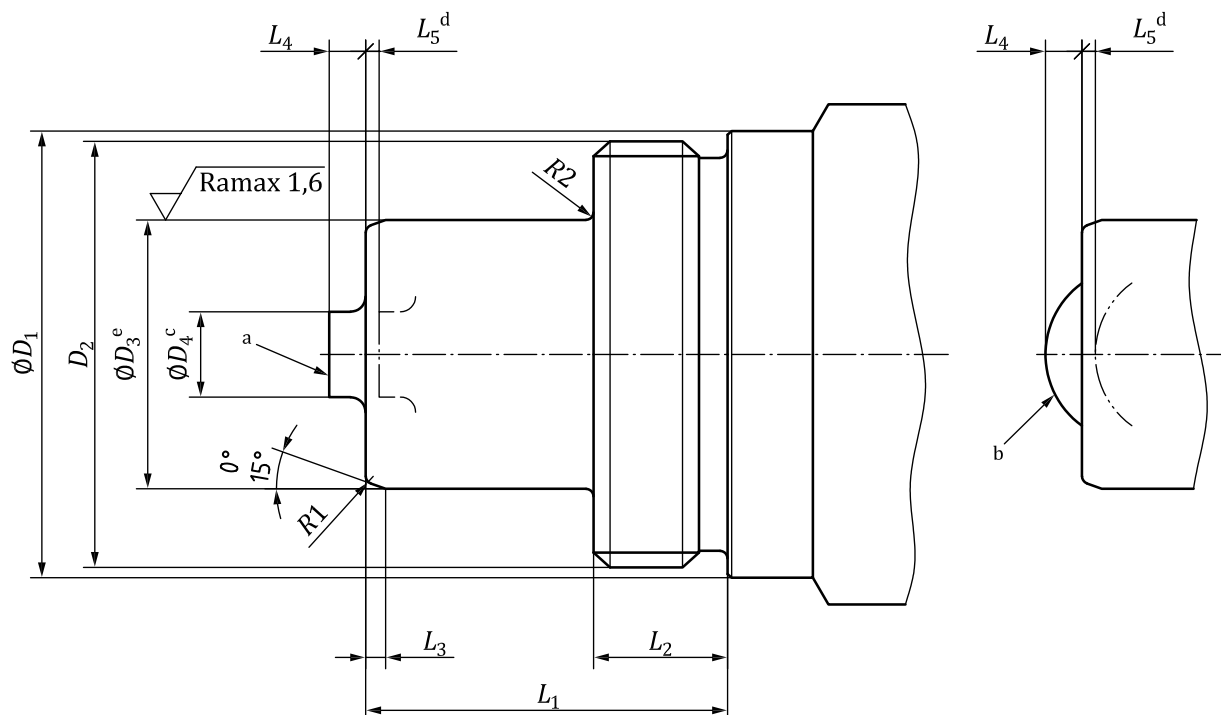

- a The shape of the valve is optional; “P” type version (with poppet valve) is shown.
- b The shape of the valve is optional; “S” type version (with spherical valve) is shown.
- c Use dimension  $D_4$ , unless the valve is spherical.
- d Maximum valve travel against stop.
- e Sealing diameter.

NOTE All dimensions and shape after  $L_1$  and  $D_1$  are left to the manufacturer.

**Figure 1 — Dimensional requirements**

**Table 1 — Dimensional requirements**

Dimensions in millimetres

Size <sup>a</sup>	$\text{Ø}D_1$	$D_2$ <sup>c</sup>	$\text{Ø}D_3$	$\text{Ø}D_4$ <sup>b</sup>	$L_1$	$L_2$	$L_3$	$L_4$	$L_5$	$R_1$	$R_2$
	min			min			max	max	max		max
6,3	26,5	1-18 UNS	15,77 15,85	1,9	18,95 19,15	7,75 7,98	2,0	4	0,4	0,5 1,0	0,6
10	31,5	1-3/16-16 UN	18,96 19,04	2,5	25,32 25,47	9,30 9,52	2,5	4	0,4	0,5 1,3	0,6

<sup>a</sup> Size designation corresponds to the nominal hose size of the recommended hose; see ISO 4397.

<sup>b</sup> Use dimension  $D_4$  unless the valve is spherical.

<sup>c</sup> In accordance with basic dimensions and formulae given in ISO 725 and ISO 5864, tolerance class 2A. See [Annex A](#) for the dimensions of the 1-18 UNS thread.

## 5 Performance requirements

5.1 Couplings conforming to this International Standard shall meet or exceed the performance requirements specified in [Table 2](#).

**Table 2 — Performance requirements by coupling size**

Performance parameter	Size 6,3 <sup>a</sup>	Size 10 <sup>a</sup>
Working pressure <sup>b</sup>	72 MPa (720 bar)	
Minimum burst pressure (coupled) <sup>c</sup>	216 MPa (2 160 bar)	
Minimum burst pressure for the “P” type (uncoupled) <sup>c</sup>	216 MPa (2 160 bar)	
Minimum burst pressure for the “S” type (uncoupled) <sup>c</sup>	144 MPa (1 440 bar)	
Rated flow <sup>d</sup>	12 l/min	23 l/min
Maximum pressure drop at rated flow <sup>d</sup>	300 kPa (3 bar)	450 kPa (4,5 bar)
Maximum fluid loss per disconnection <sup>e</sup>	0,5 ml	1 ml
Maximum residual static pressure for connection <sup>f</sup>	10 MPa (100 bar)	
<sup>a</sup> Size designation corresponds to the nominal hose size of the recommended hose; see ISO 4397. <sup>b</sup> See <a href="#">5.3</a> . <sup>c</sup> See <a href="#">5.4</a> . <sup>d</sup> See <a href="#">5.5</a> . <sup>e</sup> See <a href="#">5.6</a> . <sup>f</sup> Internal residual static pressure present in one coupling half.		

5.2 The performance requirements apply to couplings made from carbon steel. The use of any combination of other materials and the related performance requirements shall be agreed between the customer and manufacturer.

5.3 The working pressure shall be verified in both the coupled and uncoupled conditions by pressure impulse testing for 10 000 cycles at the working pressure (low-cycle fatigue test) using the test pressure wave form specified in ISO 7241-2.

5.4 The burst pressure shall be verified by testing in both the coupled and uncoupled conditions in accordance with ISO 7241-2.

5.5 The pressure drop at rated flow shall be verified by testing in accordance with ISO 7241-2.

5.6 The fluid loss per disconnection shall be verified by testing in accordance with ISO 7241-2.

5.7 The maximum residual static pressure for connection shall be verified by connecting 100 times in accordance with ISO 7241-2 at 10 MPa (100 bar) pressure present in one coupling half only.

## 6 Best practice

6.1 Manufacturers of couplings conforming to this International Standard shall give proper written information to the customer about safety, correct use, best practice, and maintenance in order to allow correct and safe use of the products.

6.2 Couplings conforming to this International Standard are subject to very high internal pressure. The final user shall always use the most suitable protection devices when using the product and shall keep out of the product’s range of action.

6.3 Couplings conforming to this International Standard are not designed to be connected and disconnected under working pressure. However, [Table 2](#) provides information about the maximum residual static pressure, which is present in one half only, that is allowable for connection.

6.4 Couplings of the “S” type, which have a spherical valve, are not preferred for applications that require that the coupling be pressurized in the disconnected condition.

## 7 Designation

Hydraulic couplings conforming to this International Standard shall be designated as follows:

- a) the word “Coupling”, followed by
- b) a reference to this International Standard (i.e. ISO 14540), followed by a spaced hyphen, followed by
- c) the size, followed by a spaced hyphen, followed by
- d) the type designation, i.e. P for a coupling with a poppet valve or S for a coupling with a spherical valve.

### EXAMPLE

Hydraulic quick-action coupling conforming to this International Standard of size 6,3 and of the “P” type is designated as follows:

**Coupling ISO 14540:—, 6,3- P**

## 8 Marking

Couplings conforming to this International Standard shall be permanently marked at least with the manufacturer’s name, logo, or product identification.

## 9 Identification statement (reference to this International Standard)

The following statement should be used in test reports, catalogues, and sales literature when electing to comply with this International Standard: “Dimensional and performance requirements conform to ISO 14540, *Hydraulic fluid power — Dimensions and requirements for screw-to-connect quick-action couplings for use at a pressure of 72 MPa (720 bar)*.”

## Annex A (normative)

### Basic dimensions of the 1-18 UNS inch screw thread

[Tables A.1](#) and [A.2](#) provide the basic dimensions of the 1-18 UNS inch screw thread. They provide dimensions of, respectively, the external and internal threads.

**Table A.1 — Dimensions for 1-18 UNS, class 2A, inch screw threads (external)**

Thread		Allowance	Major diameter		Pitch diameter		Minor diameter
			max	min	max	min	max
1-18 UNS	in	0,0014	0,9986	0,9899	0,9625	0,9578	0,9325
	mm	0,037	25,364	25,144	24,447	24,329	23,686

**Table A.2 — Dimensions for 1-18 UNS, class 2B, inch screw threads (internal)**

Thread		Minor diameter		Pitch diameter		Major diameter
		max	min	max	min	min
1-18 UNS	in	0,953	0,940	0,9701	0,9639	1,0000
	mm	24,206	23,876	24,640	24,484	25,400

## Bibliography

- [1] ISO 4397, *Fluid power connectors and associated components — Nominal outside diameters of tubes and nominal hose sizes*









# British Standards Institution (BSI)

BSI is the national body responsible for preparing British Standards and other standards-related publications, information and services.

BSI is incorporated by Royal Charter. British Standards and other standardization products are published by BSI Standards Limited.

## About us

We bring together business, industry, government, consumers, innovators and others to shape their combined experience and expertise into standards-based solutions.

The knowledge embodied in our standards has been carefully assembled in a dependable format and refined through our open consultation process. Organizations of all sizes and across all sectors choose standards to help them achieve their goals.

## Information on standards

We can provide you with the knowledge that your organization needs to succeed. Find out more about British Standards by visiting our website at [bsigroup.com/standards](http://bsigroup.com/standards) or contacting our Customer Services team or Knowledge Centre.

## Buying standards

You can buy and download PDF versions of BSI publications, including British and adopted European and international standards, through our website at [bsigroup.com/shop](http://bsigroup.com/shop), where hard copies can also be purchased.

If you need international and foreign standards from other Standards Development Organizations, hard copies can be ordered from our Customer Services team.

## Subscriptions

Our range of subscription services are designed to make using standards easier for you. For further information on our subscription products go to [bsigroup.com/subscriptions](http://bsigroup.com/subscriptions).

With **British Standards Online (BSOL)** you'll have instant access to over 55,000 British and adopted European and international standards from your desktop. It's available 24/7 and is refreshed daily so you'll always be up to date.

You can keep in touch with standards developments and receive substantial discounts on the purchase price of standards, both in single copy and subscription format, by becoming a **BSI Subscribing Member**.

**PLUS** is an updating service exclusive to BSI Subscribing Members. You will automatically receive the latest hard copy of your standards when they're revised or replaced.

To find out more about becoming a BSI Subscribing Member and the benefits of membership, please visit [bsigroup.com/shop](http://bsigroup.com/shop).

With a **Multi-User Network Licence (MUNL)** you are able to host standards publications on your intranet. Licences can cover as few or as many users as you wish. With updates supplied as soon as they're available, you can be sure your documentation is current. For further information, email [bsmusales@bsigroup.com](mailto:bsmusales@bsigroup.com).

## BSI Group Headquarters

389 Chiswick High Road London W4 4AL UK

## Revisions

Our British Standards and other publications are updated by amendment or revision.

We continually improve the quality of our products and services to benefit your business. If you find an inaccuracy or ambiguity within a British Standard or other BSI publication please inform the Knowledge Centre.

## Copyright

All the data, software and documentation set out in all British Standards and other BSI publications are the property of and copyrighted by BSI, or some person or entity that owns copyright in the information used (such as the international standardization bodies) and has formally licensed such information to BSI for commercial publication and use. Except as permitted under the Copyright, Designs and Patents Act 1988 no extract may be reproduced, stored in a retrieval system or transmitted in any form or by any means – electronic, photocopying, recording or otherwise – without prior written permission from BSI. Details and advice can be obtained from the Copyright & Licensing Department.

## Useful Contacts:

### Customer Services

**Tel:** +44 845 086 9001

**Email (orders):** [orders@bsigroup.com](mailto:orders@bsigroup.com)

**Email (enquiries):** [cservices@bsigroup.com](mailto:cservices@bsigroup.com)

### Subscriptions

**Tel:** +44 845 086 9001

**Email:** [subscriptions@bsigroup.com](mailto:subscriptions@bsigroup.com)

### Knowledge Centre

**Tel:** +44 20 8996 7004

**Email:** [knowledgecentre@bsigroup.com](mailto:knowledgecentre@bsigroup.com)

### Copyright & Licensing

**Tel:** +44 20 8996 7070

**Email:** [copyright@bsigroup.com](mailto:copyright@bsigroup.com)



...making excellence a habit.™