

Plastics pipes and fittings — Crosslinked polyethylene (PE-X) pipe systems for the conveyance of gaseous fuels — Metric series — Specifications —

Part 2: Fittings for heat-fusion jointing

ICS 75.200; 84.140.30

National foreword

This British Standard reproduces verbatim ISO 14531-2:2004 and implements it as the UK national standard.

The UK participation in its preparation was entrusted by Technical Committee PRI/88/2, Plastics piping for pressure applications, to Subcommittee PRI/88/2/6, Thermoplastics piping for gas supply, which has the responsibility to:

- aid enquirers to understand the text;
- present to the responsible international/European committee any enquiries on the interpretation, or proposals for change, and keep UK interests informed;
- monitor related international and European developments and promulgate them in the UK.

A list of organizations represented on this subcommittee can be obtained on request to its secretary.

Cross-references

The British Standards which implement international publications referred to in this document may be found in the *BSI Catalogue* under the section entitled “International Standards Correspondence Index”, or by using the “Search” facility of the *BSI Electronic Catalogue* or of British Standards Online.

This publication does not purport to include all the necessary provisions of a contract. Users are responsible for its correct application.

Compliance with a British Standard does not of itself confer immunity from legal obligations.

Summary of pages

This document comprises a front cover, an inside front cover, the ISO title page, pages ii to v, a blank page, pages 1 to 29 and a back cover.

The BSI copyright notice displayed in this document indicates when the document was last issued.

Amendments issued since publication

Amd. No.	Date	Comments

This British Standard was published under the authority of the Standards Policy and Strategy Committee on 30 June 2006

© BSI 2006

INTERNATIONAL
STANDARD

ISO
14531-2

First edition
2004-07-01

**Plastics pipes and fittings — Crosslinked
polyethylene (PE-X) pipe systems for the
conveyance of gaseous fuels — Metric
series — Specifications —**

**Part 2:
Fittings for heat-fusion jointing**

*Tubes et raccords en matières plastiques — Systèmes de tubes en
polyéthylène réticulé (PE-X) pour le transport de combustibles
gazeux — Série métrique — Spécifications —*

Partie 2: Raccords pour assemblage par fusion



Reference number
ISO 14531-2:2004(E)

Contents

Page

Foreword.....	iv
Introduction	v
1 Scope.....	1
2 Normative references	2
3 Terms and definitions.....	3
4 Materials.....	7
5 Fittings	9
6 Elastomeric seals.....	20
7 Marking	20
8 Packaging	21
Annex A (informative) Method of test of the integrity of a fitting after an external blow.....	22
Annex B (normative) Resistance to gas constituents	24
Annex C (normative) Constant-strain thermal-cycling test	25
Annex D (normative) Validation of fitting design pressure DP_F	27
Bibliography	29

Foreword

ISO (the International Organization for Standardization) is a worldwide federation of national standards bodies (ISO member bodies). The work of preparing International Standards is normally carried out through ISO technical committees. Each member body interested in a subject for which a technical committee has been established has the right to be represented on that committee. International organizations, governmental and non-governmental, in liaison with ISO, also take part in the work. ISO collaborates closely with the International Electrotechnical Commission (IEC) on all matters of electrotechnical standardization.

International Standards are drafted in accordance with the rules given in the ISO/IEC Directives, Part 2.

The main task of technical committees is to prepare International Standards. Draft International Standards adopted by the technical committees are circulated to the member bodies for voting. Publication as an International Standard requires approval by at least 75 % of the member bodies casting a vote.

Attention is drawn to the possibility that some of the elements of this document may be the subject of patent rights. ISO shall not be held responsible for identifying any or all such patent rights.

ISO 14531-2 was prepared by Technical Committee ISO/TC 138, *Plastics pipes, fittings and valves for the transport of fluids*, Subcommittee SC 4, *Plastics pipes and fittings for the supply of gaseous fuels*.

ISO 14531 consists of the following parts, under the general title *Plastics pipes and fittings — Crosslinked polyethylene (PE-X) pipe systems for the conveyance of gaseous fuels — Metric series — Specifications*:

- *Part 1: Pipes*
- *Part 2: Fittings for heat-fusion jointing*
- *Part 3: Fittings for mechanical jointing (including PE-X/mechanical transitions)*
- *Part 4: System design and installation guidelines*

Introduction

Further to the publication of International Standards for crosslinked polyethylene (PE-X) hot-water pipes, it has become evident that the properties of PE-X, in particular its high fracture resistance and a recently established socket and saddle fusion jointing capability, render it suitable for use in high-performance gas distribution systems. The philosophy of ISO 14531 is to provide the basis for the introduction of PE-X gas pipe systems by the specification of a performance range beyond that covered by existing PE standards in order to take its application into regimes of higher operating pressures and extremes of operating temperature.

ISO 14531-2 is therefore one part of a four-part system standard covering pipes, fittings for heat-fusion jointing, fittings for mechanical jointing and design and installation guidelines. The content is suitable for use by procurement authorities and distribution engineers responsible for the design, installation and operation of pipeline systems.

ISO 14531-2 is structured to provide for the supply of heat-fusion fittings with an associated heating method (e.g. electrofusion and induction fusion) that enables pipes and fittings to be pre-assembled in a separate operation prior to the commencement of the fusion-jointing process.

Plastics pipes and fittings — Crosslinked polyethylene (PE-X) pipe systems for the conveyance of gaseous fuels — Metric series — Specifications —

Part 2: Fittings for heat-fusion jointing

1 Scope

This part of ISO 14531 specifies the physical properties and mechanical performance requirements of crosslinked polyethylene (PE-X) and polyethylene (PE) socket, saddle and spigot fittings for the connection by socket or saddle heat-fusion jointing techniques of PE-X pipes manufactured in accordance with ISO 14531-1. In addition, it lays down dimensional requirements and specifies some general material properties (including chemical stability) together with a classification scheme for PE-X fitting base materials produced in the form of pipe.

This part, when used in conjunction with the other parts of ISO 14531, provides the basis for the design, manufacture and installation of PE-X piping systems (PE-X pipes, PE-X fusion fittings and mechanical fittings) for the supply of category D and category E gaseous fuels (see ISO 13623) at:

- a) maximum operating pressures (MOP) up to and including 16 bar¹⁾;
- b) a maximum operating temperature of + 60 °C;
- c) a minimum operating temperature of
 - i) – 50 °C
 - ii) – 35 °C
 - iii) – 20 °C.

Conformity to this part of ISO 14531 of PE fittings for heat-fusion jointing produced in accordance with ISO 8085-3 may be claimed subject to the satisfactory conclusion of the tests listed in 5.11 and an end use restriction on operating temperature of from – 20 °C to + 40 °C with a maximum operating pressure as determined by ISO 8085-3.

NOTE Provision is made in ISO 14531-4 for the use on a restricted temperature basis of ISO 8085 fittings conforming to 5.11 in conjunction with PE-X pipe conforming to ISO 14531-1. The technical file of the fitting manufacturer should also be consulted for relevant supporting information.

For installation purposes, this part of ISO 14531 provides for the jointing of heat-fusion fittings to PE-X pipes within the temperature range – 5 °C to + 40 °C.

1) 1 bar = 10⁵ N/m² = 100 kPa

2 Normative references

The following referenced documents are indispensable for the application of this document. For dated references, only the edition cited applies. For undated references, the latest edition of the referenced document (including any amendments) applies.

ISO 3, *Preferred numbers — Series of preferred numbers*

ISO 497, *Guide to the choice of series of preferred numbers and of series containing more rounded values of preferred numbers*

ISO 1167-1, *Thermoplastics pipes, fittings and assemblies for the conveyance of fluids — Determination of the resistance to internal pressure — Part 1: General method*

ISO 3126, *Plastics piping systems — Plastics components — Determination of dimensions*

ISO 3127, *Thermoplastics pipes — Determination of resistance to external blows — Round-the-clock method*

ISO 3458, *Assembled joints between fittings and polyethylene (PE) pressure pipes — Test of leakproofness under internal pressure*

ISO 4437, *Buried polyethylene (PE) pipes for the supply of gaseous fuels — Metric series — Specifications*

ISO 6447, *Rubber seals — Joint rings used for gas supply pipes and fittings — Specification for material*

ISO 8085-3, *Polyethylene fittings for use with polyethylene pipes for the supply of gaseous fuels — Metric series — Specifications — Part 3: Electrofusion fittings*

ISO 9080, *Plastics piping and ducting systems — Determination of the long-term hydrostatic strength of thermoplastics materials in pipe form by extrapolation*

ISO 9356, *Polyolefin pipe assemblies with or without jointed fittings — Resistance to internal pressure — Test method*

ISO 9624, *Thermoplastics pipes for fluids under pressure — Mating dimensions of flange adapters and loose backing flanges*

ISO 10147, *Pipes and fittings made of crosslinked polyethylene (PE-X) — Estimation of the degree of crosslinking by determination of the gel content*

ISO/TR 10837, *Determination of the thermal stability of polyethylene (PE) for use in gas pipes and fittings*

ISO 10838-1:2000, *Mechanical fittings for polyethylene piping systems for the supply of gaseous fuels — Part 1: Metal fittings for pipes of nominal outside diameter less than or equal to 63 mm*

ISO/TS 10839, *Polyethylene pipes and fittings for the supply of gaseous fuels — Code of practice for design, handling and installation*

ISO 11413, *Plastics pipes and fittings — Preparation of test piece assemblies between a polyethylene (PE) pipe and an electrofusion fitting*

ISO 12092²⁾, *Fittings, valves and other piping system components made of unplasticized poly(vinyl chloride) (PVC-U), chlorinated poly(vinyl chloride) (PVC-C), acrylonitrile-butadiene-styrene (ABS) and acrylonitrile-styrene-acrylester (ASA) for pipes under pressure — Resistance to internal pressure — Test method*

2) Under revision as ISO 1167-3.

ISO 12162, *Thermoplastics materials for pipes and fittings for pressure applications — Classification and designation — Overall service (design) coefficient*

ISO 13479, *Polyolefin pipes for the conveyance of fluids — Determination of resistance to crack propagation — Test method for slow crack growth on notched pipes (notch test)*

ISO 13623, *Petroleum and natural gas industries — Pipeline transportation systems*

ISO 13954, *Plastics pipes and fittings — Peel decohesion test for polyethylene (PE) electrofusion assemblies of nominal outside diameter greater than or equal to 90 mm*

ISO 13955, *Plastics pipes and fittings — Crushing decohesion test for polyethylene (PE) electrofusion assemblies*

ISO 13957, *Plastics pipes and fittings — Polyethylene (PE) tapping tees — Test method for impact resistance*

ISO 14531-1, *Plastics pipes and fittings — Crosslinked polyethylene (PE-X) pipe systems for the conveyance of gaseous fuels — Metric series — Specifications — Part 1: Pipes*

ISO 14531-3, *Plastics pipes and fittings — Crosslinked polyethylene (PE-X) pipe systems for the conveyance of gaseous fuels — Metric series — Specifications — Part 3: Fittings for mechanical jointing (including PE-X/metal transitions)*

ISO 14531-4, *Plastics pipes and fittings — Crosslinked polyethylene (PE-X) pipe systems for the conveyance of gaseous fuels — Metric series — Specifications — Part 4: System design and installation guidelines*

ISO 18553, *Method for the assessment of the degree of pigment or carbon black dispersion in polyolefin pipes, fittings and compounds*

IEC 60529, *Degrees of protection provided by enclosures (IP Code)*

3 Terms and definitions

For the purposes of this document, the following terms and definitions apply.

3.1 Fitting types

3.1.1

socket fitting

fitting with one or more cylindrical sockets into which pipes or fitting spigots can be inserted to form an assembly for subsequent jointing by heat fusion and the creation of an integral pipe/fitting connection

3.1.2

spigot fitting

fitting with one or more tubular ends capable of insertion into a socket fitting to form an assembly for subsequent jointing by heat fusion and the creation of an integral pipe-to-fitting connection

3.1.3

saddle fitting

fitting for placement on or around the outer surface of a pipe to form a saddle assembly for subsequent jointing by heat fusion and the creation of an integral pipe-to-fitting connection

3.1.4

tapping tee

saddle fitting, with various outlet configurations, containing an intrinsic tool designed to perforate the wall of the pipe whilst the pipe is under internal pressure

3.1.5

branch saddle

saddle fitting, with various outlet configurations, with provision made for the location of a separate tool designed to perforate the wall of the pipe whilst the pipe is under internal pressure or in a non-pressurised state

3.2 Terms relating to the geometry

3.2.1

nominal outside diameter

d_n

numerical designation of the pipe size which is common to all components in a thermoplastics piping system, other than flanges and components designated by thread size

NOTE It is a convenient round number used for reference purposes.

3.2.2

mean outside diameter

d_e

(pipe) quotient of the outer circumference of the pipe measured at any cross-section and π^3 , rounded up to the nearest 0,1 mm

3.2.3

mean outside diameter

$D_{1,sp}$

(spigot fitting) quotient of the outer circumference of a tubular spigot, measured in any radial plane over a distance extending up to $L_{1,sp}$ from its leading face, and π^4 , rounded up to the nearest 0,1 mm

3.2.4

minimum mean outside diameter

$d_{e,min}$

minimum value of the mean outside diameter of a pipe, specified for a given nominal outside diameter d_n

See ISO 14531-1.

3.2.5

wall thickness

e_y

(pipe) value of the measured wall thickness at any point around the circumference of a pipe, rounded up to the nearest 0,1 mm

3.2.6

wall thickness

E_y

(fitting) value of the measured wall thickness at any point around the circumference of a socket, spigot or saddle fitting that is exposed to internal pressure, rounded up to the nearest 0,1 mm

3.2.7

minimum wall thickness

$e_{y,min}$

(pipe) minimum permissible value of the wall thickness e_y at any point around the circumference of a pipe

See ISO 14531-1.

3) Taken to be 3,141 592 6..., as specified in ISO 31-11.

3.2.8**minimum wall thickness** $E_{y,\min}$

⟨fitting⟩ minimum permissible value, defined by the manufacturer, of the wall thickness E_y at any point around the circumference of a socket, spigot or saddle fitting that is exposed to internal pressure

3.2.9**penetration length** $L_{1,\text{so}}$

length from the entry face of a socket to the face of an inserted pipe or fitting spigot, selected as the basis for the fitting design

3.2.10**fusion length** $L_{2,\text{so}}$

nominal length of the fusion zone between a pipe or fitting spigot and a fitting socket

3.2.11**entry length** $L_{3,\text{so}}$

nominal length from the entry face of a socket to the beginning of the fusion zone

3.2.12**mean inside diameter** $D_{1,\text{so}}$

arithmetic mean of at least two measured inside diameters of a socket perpendicular to each other in a plane parallel to the plane of the entry face at a distance of $L_{3,\text{so}} + 0,5L_{2,\text{so}}$ from that face

3.2.13**minimum bore** $D_{2,\text{so}}$

⟨socket fitting⟩ minimum diameter of the flow channel through the bore of a socket fitting

3.2.14**minimum bore** $D_{2,\text{sp}}$

⟨spigot fitting⟩ minimum diameter of the flow channel through the bore of a spigot fitting

3.2.15**out-of-roundness**

⟨socket fitting⟩ difference between the maximum inside diameter and minimum inside diameter in any radial cross-section of a socket fitting

NOTE In the context of this part of ISO 14531, out-of-roundness is measured in millimetres.

3.2.16**out-of-roundness**

⟨spigot fitting⟩ difference between the maximum outside diameter and minimum outside diameter in any radial cross-section of a spigot fitting

NOTE In the context of this part of ISO 14531, out-of-roundness is measured in millimetres.

3.2.17**tubular length** $L_{1,\text{sp}}$

length of tubular spigot designed to fit within a socket fitting

3.3 Terms relating to fuel and service conditions

3.3.1

gaseous fuel

fuel which is in the gaseous state at a temperature of + 15 °C and at a pressure of 1 bar

3.3.2

category D gaseous fuel

natural gas

NOTE Categories of gaseous fuel are defined in detail in ISO 13623.

3.3.3

category E gaseous fuel

LPG vapour; natural gas or LPG vapour conveyed in association with intrinsic liquid condensates

NOTE Categories of gaseous fuel are defined in detail in ISO 13623.

3.3.4

fitting design pressure

DP_F

pressure on which design calculations are based

3.3.5

pipeline operator

private or public organisation authorised to design, construct and/or operate and maintain a gas supply system

3.4 Terms relating to materials

3.4.1

crosslinked polyethylene PE-X

polyethylene structure within which the polymer chains are interconnected by chemical bonds to create a three-dimensional polymer network

NOTE The properties of the three-dimensional structure ensure that it is not possible to melt or dissolve the polymer. The extent of crosslinking is related to the mass of insoluble material remaining following solvent extraction and can be determined by measurement of the gel content.

3.4.2

base material

physical blend of non-crosslinked polyethylene(s) and additives formulated to facilitate conversion to PE-X during the production of fittings to conform to this part of ISO 14531

3.4.3

lower confidence limit of the predicted hydrostatic strength

σ_{LPL}

quantity, with the dimensions of stress, which represents the 97,5 % lower confidence limit of the predicted hydrostatic strength at a temperature θ and time t in water

NOTE It is denoted by $\sigma_{LPL} = \sigma_{(\theta, t, 0,975)}$.

3.4.4

overall service (design) coefficient

C

overall coefficient, with a value greater than 1,0, that takes into consideration service conditions as well as properties of the components of a piping system other than those represented in σ_{LPL}

3.4.5**minimum required strength****MRS**

value of σ_{LPL} at a temperature of 20 °C and a time of 50 years ($\sigma_{(20, 50 \text{ years}, 0,975)}$) rounded down to the nearest value in the R10 or R20 series specified in ISO 3 or ISO 497, depending on the value of σ_{LPL}

4 Materials**4.1 General**

Where PE-X and PE materials are used in the manufacture of fittings conforming to this part of ISO 14531 they shall conform to 4.2 and 4.3 as appropriate. Interlayers may be introduced to facilitate the fusion jointing of PE-X fittings to PE-X pipes provided they conform to a relevant standard. Pipe/fitting assemblies with interlayers shall meet the requirements specified in this part of ISO 14531.

Other materials (e.g. plastics, rubbers and metals) utilised in the manufacture of fittings to this part of ISO 14531 shall be supplied in accordance with a relevant ISO standard. For rubber ring seals, the applicable standard shall be ISO 6447. Alternative standards may be utilised in cases where suitable ISO standards do not exist. In such cases, fitness for purpose shall be demonstrated by the fitting manufacturer.

All metal parts susceptible to corrosion shall be adequately protected. When dissimilar metallic materials are used which may be in contact with moisture, steps shall be taken to avoid the possibility of galvanic corrosion.

The manufacturer of the fittings shall maintain the availability of a technical file (generally confidential) with all relevant data to prove the conformity of fittings to this part of ISO 14531. It shall include all the results of type testing. Any change in the materials used that is likely to affect product quality and performance shall require a re-assessment of material performance against the requirements of this part of ISO 14531.

4.2 Crosslinked PE (PE-X)**4.2.1 General**

Base material used in the manufacture of fittings meeting the performance requirements described in Clause 5 shall be crosslinked by the peroxide (PE-Xa), silane (PE-Xb) or electron beam (PE-Xc) crosslinking process or, subject to consultation with the pipeline operator, by another process.

4.2.2 Performance

PE-X shall conform to the requirements for fracture resistance given in Table 1 when tested in the form of pipe.

The chemical stability of PE-X shall be shown to meet the requirements listed in Table 2, using test pieces in the form of pipe.

Conformity to this part of ISO 14531 shall be demonstrated by the material and/or fitting manufacturer and shall relate to one source of base material and associated fitting-manufacturing method.

Table 1 — Fracture characteristics of PE-X material in the form of pipe

Characteristic	Units	Requirement	Test parameters	Test method
Slow crack growth	h	No failure when tested to 5 000 h	Temperature: 80 °C Pressure: PE-X 80: 8,0 bar PE-X 100: 9,2 bar PE-X 125: 10,8 bar	ISO 13479 Pipe test piece $d_n \geq 110$ mm or 125 mm, SDR 11 ^a
^a As specified in ISO 14531-1.				

Table 2 — Chemical stability of PE-X in the form of pipe

Characteristic	Units	Requirement	Test parameters	Test method
Long-term stability	h	No failure when tested to 8 760 h	Temperature: 110 °C Pipe hoop stress: 2,5 MPa	ISO 1167-1 Type a) end caps ^a Pipe test piece $d_n = 32$ mm SDR 11 ^b
^a Internal/external environment — water/air.				
^b As specified in ISO 14531-1.				

4.2.3 Classification

PE-X shall conform to the MRS classification and material designation requirements given in Table 3.

Classification testing and evaluation shall be undertaken in the manner described in ISO 1167-1, ISO 12162, and ISO 9080.

In addition, the long-term hydrostatic strength σ_{LTHS} shall be derived from the available test data for the temperature range 10 °C to 100 °C and shall be expressed in the form:

$$\log t = A + \frac{B \times \log \sigma_{\text{LTHS}}}{\theta} + \frac{C}{\theta} + D \times \log \sigma_{\text{LTHS}}$$

where

θ is the temperature, in kelvins;

t is the time, in hours;

σ_{LTHS} is the predicted mean hydrostatic strength, in megapascals, at temperature θ and time t ;

A , B , C and D are coefficients determined from experimental data.

Table 3 — Classification of PE-X in the form of pipe

Designation	σ_{LPL} (20 °C, 50 years, 97,5 %) MPa	MRS MPa
PE-X 80	$\geq 8,00$ $\leq 9,99$	8,0
PE-X 100	$\geq 10,00$ $\leq 12,49$	10,0
PE-X 125	$\geq 12,50$ $\leq 13,99$	12,5

4.3 Polyethylene (PE)

4.3.1 General

PE shall conform to the material requirements of ISO 8085-3.

4.3.2 Reprocessable material

PE-X shall not be reprocessed and used in the manufacture of fittings to this part of ISO 14531.

Non-crosslinked base material fittings, produced in the course of manufacturing PE-X fittings to meet the requirements of this part of ISO 14531, may be reprocessed if derived from the same non-crosslinked material grade already employed in the relevant production. Products containing reprocessed material shall conform to the requirements of this part of ISO 14531.

The use of reprocessable PE material shall be as specified in ISO 4437 and ISO 8085-3.

4.4 Surface coatings

Where applicable, materials used for external surface coatings, e.g. for colour-coded end-use identification systems, shall not have a detrimental effect on the ability of the product to conform to the performance requirements of this part of ISO 14531 or to withstand handling and installation in accordance with ISO 14531-4.

5 Fittings

5.1 Design

Fittings produced in accordance with this part of ISO 14531 shall be of the socket, spigot or saddle type designed for jointing by heat fusion to create socket- and saddle-jointed assemblies incorporating PE-X pipes.

The fitting design pressure DP_F at a temperature of 20 °C shall be declared by the fitting manufacturer in accordance with Table 4 and recorded in the manufacturer's technical file. The declaration of design pressure shall take into account stress concentration effects generated by the fitting and joint assembly geometries and shall be supported by the provision of appropriate experimental data (see 5.10) and/or design calculations.

The effect on the design pressure at 20 °C of variations in temperature from 0 °C to + 60 °C shall be determined for use in accordance with ISO 14531-4. For temperatures greater than 20 °C, up to and including

60 °C, derating factors shall be established and included in the technical file. Uprating factors for temperatures in the range 0 °C to 20 °C shall also be established and incorporated in the manufacturer's technical file.

NOTE The pipeline operator is required by ISO 14531-4 to ensure that $MOP \leq DP_F$.

Table 4 — Fitting design pressure DP_F at 20 °C

Fitting type	DP_F bar
Type 1	2,0
Type 2	5,0
Type 3	10,0
Type 4	16,0

Fitting design shall take into account the expectation of a minimum pipe/fitting component temperature of – 5 °C and a maximum of + 40 °C prior to fusion. Preheating of components is permissible and, if applicable, both the equipment and guidance on use shall be supplied by the fitting manufacturer.

Fittings and associated fusion joints shall conform to the requirements detailed in 5.2 to 5.9 of this part of ISO 14531, using an appropriate combination of PE-X and/or PE materials (MRS) and the minimum fitting wall thickness $E_{y,min}$.

Account shall be taken in the fitting design of the need to avoid excessive deformation of fittings during handling and storage in accordance with ISO 14531-4 and the combined effect of DP_F and installation bending stresses (see ISO 14531-4) on the intended design life.

Flanged connections shall, in addition, meet the requirements of ISO 14531-3.

5.2 Fusion-jointing compatibility

Conformity to 5.8 shall be taken as a demonstration of the fusion-jointing compatibility of fittings with PE-X pipes.

The fitting manufacturer shall declare the types of pipe/material conforming to ISO 14531-1 to which his fittings can be fused, together with the required fusion parameters. A declaration of compatibility based on 5.8 shall be made for each class of pipe material evaluated (e.g. PE-Xa 80, PE-Xb 100 or PE-Xc 125). The declaration shall be based upon the results of tests carried out on one manufacturer's range of pipes. The extension of the compatibility declaration to pipes produced by another manufacturer within the same material class shall be dependent upon the successful conclusion of the interface cohesion test and the 95 °C/165 h hydrostatic-strength test given in Table 5. For PE fittings the 165 h test shall be conducted in accordance with ISO 8085-3 (see 5.11).

The compatibility declaration shall be incorporated in the fitting manufacturer's technical file.

5.3 Appearance

When viewed without magnification, the internal and external surfaces shall be clean and free from scoring, cavities and other defects that may prevent the fitting conforming to the requirements of this part of ISO 14531.

The fitting shall be designed to ensure that the internal and external surfaces of the pipe and fitting assembly after fusion jointing shall not exhibit projecting melt exudation apart from that used deliberately as a fusion marker.

The internal surfaces of adjoining pipes in any fusion joint shall not be visibly creased following completion of the fusion-jointing process.

Table 5 — Mechanical characteristics of jointed PE-X pipe/PE-X fitting assemblies

Characteristic	Units	Requirement	Test parameters	Test method
Hydrostatic strength	h	No failure when tested to 1 000 h ^a	Temperature: 20 °C Stress: PE-X80 8,3 MPa PE-X100 10,4 MPa PE-X125 13,0 MPa	ISO 9356
		No failure when tested to 165 h	Temperature: 95 °C Stress: PE-X80 3,8 MPa PE-X100 4,8 MPa PE-X125 6,0 MPa	
		No failure when tested to 1 000 h	Temperature: 95 °C Stress: PE-X80 3,7 MPa PE-X100 4,7 MPa PE-X125 5,9 MPa	
Resistance to impact		No visible cracking in fitting or joint	Temperature: – 50 °C ^b Drop height: 2 m Mass of striker: 2,5 kg	Annex A ISO 13957 ^c Saddle fitting
Interface cohesion		Length of brittle failure ≤ 33 % of fusion length	Temperature: 23 °C	ISO 13954 ISO 13955
Pressure drop/flow rate ^c	m ³ /h	As measured air flow rate	Pressure drop: 0,1 mbar (> 63 mm) 0,5 mbar (≤ 63 mm)	ISO 10838-1
Resistance to gas constituents	h	No failure when tested to 1 000 h	Temperature: 80 °C Pipe hoop stress: 2 MPa	ISO 1167-1 Type a) end caps Fitting/pipe assembly: $d_n = 32$ mm, SDR 11 Annex B
Tensile strength (constant strain)		No failure in fitting or joint	Temperature: + 60 °C/– 50 °C ^b No. of cycles = 50	Annex C
<p>^a Tests may be conducted for 100 h at 20 °C using an appropriate stress level established by correlation with 1 000 h data. In cases of dispute, the test time shall be 1 000 h.</p> <p>^b Alternative test temperatures of – 20 °C or – 35 °C may be used to qualify material for minimum operating temperatures greater than – 50 °C (see Clause 1). The minimum operating temperature shall be given in the fitting manufacturer's technical file.</p> <p>^c Tapping tee requirement only.</p>				

5.4 Electrical properties

Electrically powered fittings shall be designed to prevent direct or indirect contact with live conductors during the fusion-jointing process. The actual protection required shall take account of operating voltage, anticipated work site conditions and national regulations. Conformity with IEC 60529 is also necessary.

NOTE During the fusion-jointing process, the fitting is considered to be part of an electrical system as defined by IEC 60335, IEC 60364 and IEC 60449.

The fitting design shall prevent, during the fusion operation, the generation of short circuits between any electrically powered heating wires located within the joint assembly.

Protection against direct contact with active parts (live conductors) shall be provided. The protection shall conform to IEC 60529. This protection is a function of the work site conditions (see ISO/TS 10839).

Heating wires shall not be located in the operating path of pipe perforation tools.

5.5 Connections under pressure

Tapping tee and branch saddle fitting assemblies shall be designed to be attached and connected to pressurised pipes whilst preventing uncontrolled leakage of gas to the atmosphere.

Branch saddle fittings and/or equipment shall be designed to provide support against all forces generated during mains cutting operations on pressurised pipes.

Tapping tees shall permit the conduct of pressure tests on the outlet branch line and its associated joints before the mains pipe is perforated and gas allowed to flow into the branch.

Integrally guided mains perforation tools shall be capable of operation over a pipe temperature range of $-5\text{ }^{\circ}\text{C}$ to $+40\text{ }^{\circ}\text{C}$.

NOTE The minimisation of cutting torque is, for practical reasons, a key feature of the design of manually operated tools.

Fitting design shall ensure that integral tooling, including mechanical closure plugs, during and after use, is fully resistant to blow-out from the fitting body when exposed to the DP_F internal to external pressure differential.

The leaktightness of mechanical closures shall be demonstrated by subjecting fitting closure assemblies to a leaktightness test at $1,5DP_F$ and $23\text{ }^{\circ}\text{C}$ for 24 h in accordance with ISO 3458, except that air or inert gas shall be used instead of water. Water may be used for tests in which the pressure is ≥ 6 bar. Its use shall be recorded in the manufacturer's technical file.

Where mechanical closure systems are used following mains intervention operations, the closure assembly shall incorporate a plugging arrangement within the fitting assembly. The mains pipe shall not be used as a location for the closure plug.

5.6 Identification

Fitting identification features (e.g. marking and surface colouring) shall be incorporated in a form that enables PE-X fittings to be visually distinctive among adjacent buried pipework. Marking shall be in accordance with Clause 7 and Table 6.

5.7 Dimensions and tolerances

5.7.1 General

The dimensions of the fittings shall be measured not less than 24 h after manufacture in accordance with ISO 3126, after conditioning for at least 4 h.

5.7.2 Socket fittings

5.7.2.1 Principal dimensions

A cross-section of a pipe and socket fitting assembly with the principal fitting dimensions identified is shown in Figure 1.

Table 6 — Minimum required marking

Item	Marking
Reference to this part of ISO 14531 ^a	ISO 14531-2
Manufacturer's name or trademark ^b	Name or symbol
Fuel to be conveyed ^a	Gas
Designation of material	e.g. PE-Xa 100
Nominal outside diameter(s) d_n of pipe(s) to which the fitting is intended to be joined	e.g. 125
Material classification of pipe(s) to which connection is permissible, including details of pipe manufacturer ^c	e.g. PE-Xa 100/Manufacturer XXX
Applicable pipe series	SDR (e.g. SDR 11 and/or SDR 17,6) or SDR range 11/26
Manufacturing information ^b	The production period (year and month in figures or in code) The name or code for production site if manufacturer produces at different sites, nationally or internationally
Fitting type and design pressure DP_F ^c	e.g. Type 1 (2 bar)
Operating temperature range, in degrees Celsius ^c	e.g. - 50/+ 60
^a This information may be printed on a label associated with the fitting or on a bag containing an individual fitting. ^b To provide traceability. ^c This information shall be included in the fitting manufacturer's technical file.	

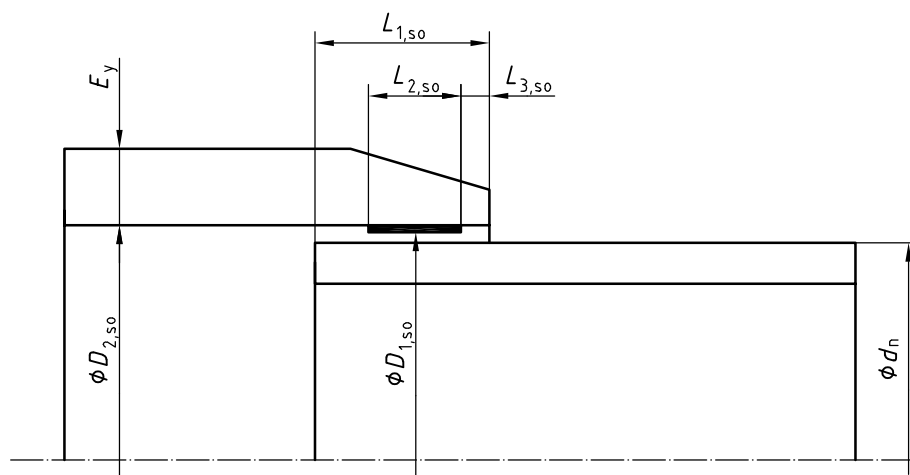

E_y is the wall thickness at any point around the circumference of the fitting, with a minimum permissible value $E_{y,min}$ as defined by the fitting manufacturer.

$L_{1,so}$, $L_{2,so}$, and $L_{3,so}$ are, respectively, the penetration length, fusion length and entry length of the fitting as specified in Table 7.

$D_{1,so}$ and $D_{2,so}$ are, respectively, the mean inside diameter at the centre of the fusion zone and the minimum bore of the fitting, as defined by the fitting manufacturer.

Figure 1 — Pipe and socket fitting assembly

5.7.2.2 Length

Socket fittings shall conform to the lengths specified in Table 7.

Socket couplings without internal pipe stops shall have an overall length not exceeding $2L_{1,so,max}$.

NOTE If accepted by the pipeline operator for special applications (e.g. repair and tie-in connections), couplings with overall lengths greater than $2L_{1,so,max}$ may be supplied, although such couplings may not be suitable for assembly with spigot fittings conforming to Table 8.

Table 7 — Socket length dimensions

Dimensions in millimetres

Nominal outside diameter d_n	Maximum depth of penetration $L_{1,so}$	Minimum length of fusion zone $L_{2,so}$	Minimum length of socket entry zone $L_{3,so}$
16	41	10	5
20	41	10	5
25	41	10	5
32	44	10	5
40	49	10	5
50	55	10	5
63	63	11	5
75	70	12	5
90	79	13	5
110	82	15	5
125	87	16	5
140	92	18	5
160	98	20	5
180	105	21	5
200	112	23	5
225	120	26	5
250	129	33	5
280	139	35	5
315	150	39	5
355	164	42	5
400	179	47	5
450	195	51	5

5.7.2.3 Inside diameter

The mean inside socket diameter $D_{1,so}$ shall not be less than the specified minimum mean outside diameter $d_{e,min}$ of the connecting pipe. The manufacturer shall declare the respective minimum and maximum values of $D_{1,so}$ for quality-control inspection purposes. The maximum value of $D_{1,so}$ shall be used as the basis for the preparation of test piece assemblies in accordance with ISO 11413.

The minimum bore $D_{2,so}$ shall be equal to or greater than $d_n - 2e_{y,min}$.

Out-of-roundness within the fitting in any plane shall not exceed $0,015d_n$.

5.7.3 Spigot fittings

5.7.3.1 Principal dimensions

A cross-section of a spigot fitting with the principal dimensions identified is shown in Figure 2.

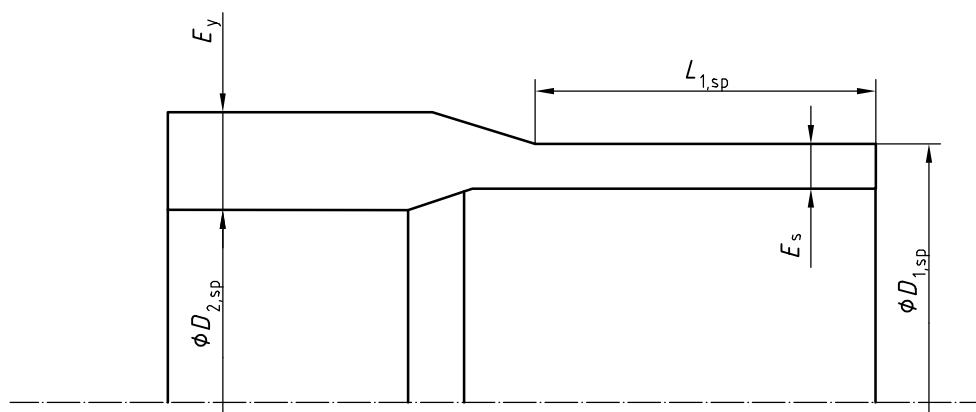

E_y is the wall thickness at any point around the circumference of the fitting, with a minimum permissible value $E_{y,min}$ as defined by the fitting manufacturer.

E_s is the wall thickness of the tubular part of the spigot as defined by the fitting manufacturer.

$L_{1,sp}$ is the length of the tubular part of the spigot designed to fit within a socket fitting as specified in Table 8.

$D_{1,sp}$ and $D_{2,sp}$ are, respectively, the outside diameter of the tubular part of the spigot designed to fit in a socket fitting and the minimum bore of the fitting, as specified in Table 8.

Figure 2 — Spigot fitting

5.7.3.2 Diameter and length

Spigot fittings shall conform to the diameters and lengths specified in Table 8.

Table 8 — Diameters and lengths of spigot fittings

Dimensions in millimetres

Nominal outside diameter d_n	Mean outside diameter of spigot $D_{1,sp}$		Maximum out of roundness	Bore diameter $D_{2,sp}$ min.	Tubular length $L_{1,sp}$ min.
	min.	max.			
16	16	16,3	0,3	9	41
20	20	20,3	0,3	13	41
25	25	25,3	0,4	18	41
32	32	32,3	0,5	25	44
40	40	40,4	0,6	31	49
50	50	50,4	0,8	39	55
63	63	63,4	0,9	49	63
75	75	75,5	1,2	59	70
90	90	90,6	1,4	71	79
110	110	110,7	1,7	87	82
125	125	125,8	1,9	99	87
140	140	140,9	2,1	111	92
160	160	161,0	2,4	127	98
180	180	181,2	2,7	143	105
200	200	201,3	3	159	112
225	225	226,4	3,4	179	120
250	250	251,5	3,8	199	130
280	280	281,6	4,2	223	150
315	315	316,8	4,8	251	150
355	355	357,1	5,4	283	165
400	400	402,3	6,0	319	180
450	450	452,6	6,8	359	195

5.7.4 Saddle fittings (tapping tee and branch saddles)

5.7.4.1 Principal dimensions

Cross-sections of pipe and saddle fitting assemblies (tapping tee and branch saddle) with the principal dimensions identified are shown in Figures 3 and 4.

5.7.4.2 Outlet branch (tapping tee)

Figure 3 illustrates the key dimensions for pipe and tapping tee assemblies. The dimension L_1 from the centreline of the tapping tee stack to the leading face of the outlet branch and the dimension L_2 from the

centreline of the outlet branch to the crown of the pipe shall be selected in combination to provide sufficient clearance around the outlet branch to permit connection of the service pipe using appropriate clamping tools.

The distance L_2 shall be kept to a minimum.

The distance from the top of the tapping tee stack to the top of the main L_3 shall be kept to a minimum.

L_2 and L_3 shall be recorded in the manufacturer's technical literature.

The exit of the outlet branch shall be designed either in the form of a socket with dimensions conforming to 5.7.2.1, 5.7.2.2 and Table 7 of this part of ISO 14531 or as a spigot with a diameter and tubular-length specification as defined in Table 8.

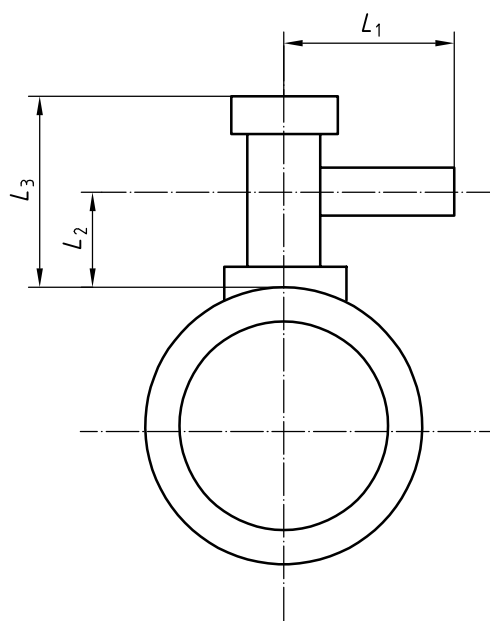

Figure 3 — Pipe and tapping tee fitting assembly

5.7.4.3 Outlet branch (branch saddle)

The outlet branch may terminate with various connection configurations (e.g. socket, spigot or stub flange) as illustrated in Figure 4.

A socket termination shall conform to the requirements given in 5.7.2 and Table 7 covering socket diameter and length.

A spigot termination shall conform to the spigot diameter and tubular-length specification defined in 5.7.3 and Table 8.

The stub flange adaptor arrangement shall conform to ISO 9624 and be designed for connection to a flanged stop valve.

For branch saddle connections to a mains pipe pressurised to DP_F , the distance from the pipe surface to the leading face of the branch L_B (see Figure 4) shall be selected to facilitate the perforation of the mains pipe, taking into account the connection arrangement and stroke of the pipe perforation tool and the possible use of flow-arresting devices such as valves and squeeze-off units. Branch saddle arrangements intended solely for non-pressurised pipes need not be designed to take account of flow-arresting operations.

NOTE Until the standardisation of pipe perforation tools is achieved, the fitting manufacturer should indicate in his technical file the tool and valve combinations with which his fitting is dimensionally compatible.

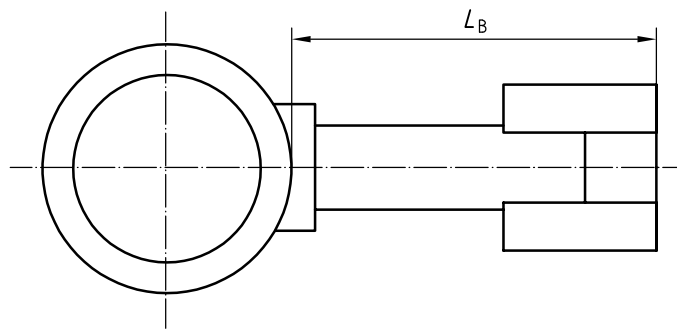

a) Socket outlet

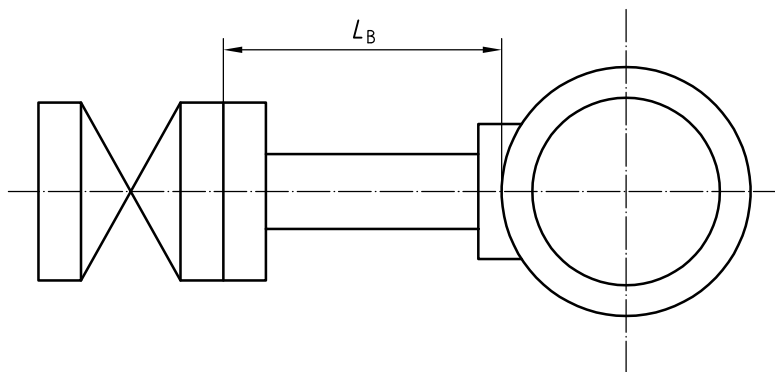

b) Stub flange outlet

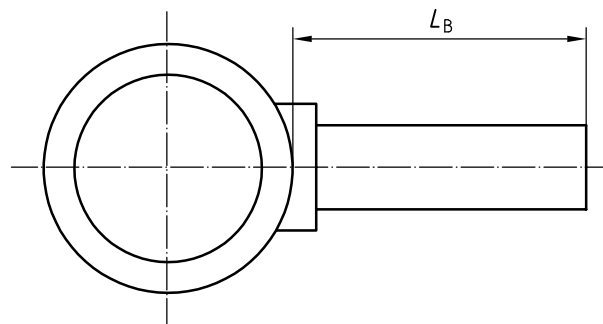

c) Spigot outlet

Figure 4 — Pipe and branch saddle fitting assemblies

5.8 Mechanical characteristics

Pipe and fitting joints shall be assembled for test in accordance with the fitting manufacturer's instructions and the procedure variations described in ISO 11413 for electrofusion jointing. For jointing methods other than electrofusion, e.g. induction fusion, ISO 11413 shall apply as appropriate.

For each type of fitting, the test schedule shall reflect the size range offered by the manufacturer, including at least the minimum and maximum sizes in the range.

When evaluated in accordance with the test methods specified in Table 5, using the parameters indicated, the jointed pipe/fitting test piece shall conform to the requirements given in Table 5.

Jointed pipe/fitting test pieces prepared for hydrostatic-strength tests shall be based upon the thickest-walled highest-pressure-rated pipe for which the fitting was designed. The pipe material used shall be selected in accordance with the fusion-compatibility statement(s) given in 5.2.

PE fittings and associated fusion joints intended for restricted applications (temperature range $-20\text{ }^{\circ}\text{C}$ to $+40\text{ }^{\circ}\text{C}$ and pressures of up to 10 bar) shall conform to the mechanical performance requirements detailed in ISO 8085-3 and the requirements given in 5.11. Conformity and approval to use the fitting with PE-X pipes shall be registered in the manufacturer's technical file.

Test pieces subjected to internal pressurisation shall use an internal pressure determined by the following equation:

$$p = \frac{20\sigma}{\frac{d_{e,\min}}{e_{y,\min}} - 1}$$

where

p is the internal test pressure, in bars;

σ is the value of the hydrostatic stress, in megapascals, corresponding to the test duration and test temperature conditions given in the relevant table;

$d_{e,\min}$ is the minimum value of the mean outside diameter specified for a given nominal outside diameter d_n of the adjoining pipe(s) (see ISO 14531-1);

$e_{y,\min}$ is the minimum permissible value for the wall thickness e_y at any point around the circumference of the adjoining pipe(s) (see ISO 14531-1).

NOTE The test parameters given for hydrostatic-strength testing in Table 5 were derived using experimental data supplemented by theoretical calculations. As experience is gained in the implementation of this part of ISO 14531, the values specified may be reviewed.

5.9 Physical characteristics

PE-X fittings shall have the physical characteristics specified in Table 9.

PE fittings and associated fusion joints intended for restricted applications (temperature range $-20\text{ }^{\circ}\text{C}$ to $+40\text{ }^{\circ}\text{C}$ and pressures of up to 10 bar) shall conform to the physical performance requirements detailed in ISO 8085-3.

Table 9 — Physical characteristics of PE-X fittings

Characteristic	Units	Requirement	Test parameters	Test method
Gel content ^a		$\geq 60\%$ but $\leq 90\%$ ^b		ISO 10147 ^c
Pigment/carbon black dispersion		\leq grade 3		ISO 18553
Thermal stability	min	> 20	$200\text{ }^{\circ}\text{C}$ ^d	ISO/TR 10837

^a Not applicable to interlayer material introduced to facilitate fusion jointing.

^b A tolerance of $\pm 5\%$ shall apply to the manufacturer's declared value at any point in the body of the fitting.

^c Samples of radial thickness 0,1 mm to be used for measurement of gel content. Samples to be taken at least from the outer and inner surfaces of the PE-X fitting and the mid-wall position.

^d Testing at $210\text{ }^{\circ}\text{C}$ is permissible if correlation with $200\text{ }^{\circ}\text{C}$ data can be demonstrated.

5.10 Validation of fitting design and design pressure, DP_F

5.10.1 General

The fitting manufacturer shall declare a fitting design pressure that shall be validated by the conduct of a series of time-dependent pressure tests or by the results of a design/stress analysis of the fitting assembly. The pressure test referred to in 5.10.2 is structured to focus on the determination of the strength of the fitting by minimising the possibility of pipe failure.

5.10.2 PE-X and PE fittings

The fitting design pressure DP_F shall be validated by the conduct of internal pressure tests at 20 °C on pipe/fitting assemblies (see Annex D).

5.11 Performance requirements for fittings in conformity with ISO 8085-3

Fittings that conform to ISO 8085-3 shall be deemed to be suitable for use with PE-X pipes conforming to ISO 14531-1 in the temperature range from – 20 °C to + 40 °C when the following tests are satisfactorily concluded:

- a) Resistance to impact described in Table 5, conducted at a temperature of – 20 °C.
- b) Validation of the fitting design pressure DP_F (see 5.1 and 5.10).
- c) Fusion-compatibility interface cohesion test (see Table 5) and the 80 °C/165 h pressure test defined in ISO 8085-3.

6 Elastomeric seals

The material of elastomeric sealing rings incorporated in the design of fitting and joint assemblies shall conform to the requirements of ISO 6447.

The sealing ring and any associated lubricant shall have no detrimental effect on the properties of the connecting pipe or fitting. The effect of lubricants shall be established in accordance with ISO 10838-1:2000, Subclause 4.4.

The leaktightness of sealing rings shall not be impaired by variations in operating temperature throughout the specified ranges of – 50 °C to + 60 °C, – 35 °C to + 60 °C, and – 20 °C to + 60 °C (– 20 °C to + 40 °C for restricted applications).

7 Marking

7.1 Legibility

Marking shall be legible without magnification.

Legibility shall be maintained during storage, handling and use in accordance with ISO/TS 10839.

7.2 Damage

Marking shall not initiate cracks or other types of failure in the fitting.

Marking shall not be applied to surfaces intended for fusion jointing.

7.3 Minimum marking requirements

The marking on PE-X fittings shall include the minimum information given in Table 6.

Marking of PE fittings shall be in accordance with the requirements specified in ISO 8085-3, with the following additional information provided in the manufacturer's technical file:

- a reference to this part of ISO 14531, i.e. ISO 14531-2;
- the material classification of the pipe(s) to which connection is permissible, including details of the pipe manufacturer;
- the fitting type and its design pressure;
- the operating-temperature range.

8 Packaging

The fittings shall be packaged in bulk, or individually protected where necessary in order to prevent deterioration. Whenever possible, they shall be placed in individual bags within cardboard boxes or cartons.

Annex A (informative)

Method of test of the integrity of a fitting after an external blow

A.1 Scope

This annex specifies a method for determining the integrity of a fitting following an externally applied impact force.

A.2 Principle

A heat-fusion-jointed pipe/fitting assembly clamped to a horizontal base plate is struck once, under specific conditions, by a weight falling onto its most critical position, i.e. the position on the fitting assembly where damage is most likely to impair its performance. The assembly is then tested for any effects of the impact force upon leaktightness.

A.3 Apparatus

A.3.1 Clamping fixture, with a means of clamping to a rigid base the test assembly at each outlet pipe close to the pipe-to-fitting joint.

A.3.2 Falling-weight test machine, conforming to ISO 3127, incorporating a type d25 striker.

A.3.3 Temperature-conditioning apparatus, capable of maintaining the test piece at a temperature within $\pm 1,5$ °C of the value specified in Table 5.

A.4 Test piece

The test piece shall comprise an assembly of pipe(s) and fitting(s) in the as-manufactured condition. Fusion joints shall be constructed at an ambient temperature of (23 ± 3) °C.

A.5 Procedure

- a) Mount the assembly in the clamping fixture so that, when it is tested as described in c), the striker will impact upon the mid-point of the fusion-jointed zone.

Set the falling-weight test machine so that the height of fall of the striker to the point of contact with the assembly is as specified in Table 5.

- b) Place the clamped assembly in the temperature-conditioning apparatus and condition it at the temperature specified in Table 5 for a time at least as long as that specified in ISO 1167-1 for the appropriate fitting wall thickness. Any conditioning fluids used shall not affect the properties of the test piece.
- c) Remove the assembly from the temperature-controlled environment. Position it in the test machine and release the falling weight so the striker falls onto the applicable point on the test assembly. The assembly shall be impacted within the following time interval after its removal from the conditioning environment:

- 1) 30 s for $d_n \leq 110$ mm;
 - 2) 90 s for $110 < d_n \leq 200$ mm;
 - 3) 180 s for $d_n > 200$ mm.
- d) Inspect the test piece visually for and record the details of the position and appearance of any evidence of cracking after impact.
- e) Immediately implement the following consecutive procedures, avoiding delays between each step;
- 1) condition the test piece for 24 h at (23 ± 3) °C;
 - 2) conduct a leaktightness test in accordance with ISO 3458 at a test pressure of 25 mbar;
 - 3) conduct a second leaktightness test at 1,5 times the design pressure DP_F .

Use air or an inert gas as the test medium for fittings intended for gas applications up to a leak test pressure of 6 bar if required by national safety regulations. The test medium for pressures greater than 6 bar shall be water.

At the end of each stage of the leaktightness test, inspect the test piece before depressurising and record the position of any leakage. National safety regulations shall be taken into account during inspection for leakage.

NOTE Attention is drawn to the need to contain the possible effects of failure of components subjected to impact testing or destructive testing.

A.6 Test report

The test report shall include the following information:

- a) a reference to this part of ISO 14531, i.e. ISO 14531-2;
- b) full identification of the product, including manufacturer, type and size of fitting, and production date;
- c) the test temperature;
- d) a description of any visible evidence of cracking and/or leakage after impact;
- e) any factors which may have affected the results, such as any incidents or operating details not specified in this part of ISO 14531;
- f) the date of the test.

Annex B (normative)

Resistance to gas constituents

B.1 Test pieces

The following test shall be carried out on a pipe/fitting assembly of $d_n = 32$.

B.2 Procedure

Prepare a synthetic condensate comprising a mixture of 50 % (by mass) *n*-decane (99 %) and 50 % (by mass) 1,3,5-trimethylbenzene.

Condition the test piece by filling it with condensate and allowing it to stand in air for 1 500 h at (23 ± 2) °C. Immediately after the conditioning period, carry out the test specified in ISO 1167-1 with the synthetic condensate inside the pipe and water outside, using the test parameters specified in Table 5.

A conditioning period of 24 h at 80 °C may be employed as an alternative but, in cases of dispute, the 1 500 h at 23 °C conditions shall apply.

Care shall be taken in handling the chemicals used in the test and to avoid contamination of equipment normally used for conventional testing with water.

B.3 Test report

The test report shall include the following information:

- a) a reference to this part of ISO 14531, i.e. ISO 14531-2;
- b) complete identification of the fitting, including manufacturer, nominal outside diameter d_n , type of material (e.g. PE-Xa) and production date;
- c) the mean outside diameter of the pipe d_e ;
- d) the minimum wall thickness of the pipe $e_{y,min}$;
- e) the conditioning parameters, including an analysis of the condensate;
- f) the test pressure;
- g) the duration of the test;
- h) details of the location and mode of any failure;
- i) any factors which may have affected the results, such as any incidents or any operating details not specified in this part of ISO 14531;
- j) the date of the test.

Annex C (normative)

Constant-strain thermal-cycling test

C.1 Scope

This annex specifies a method for determining the strength and leaktightness of a fusion-jointed fitting/pipe assembly when subjected to forces generated by a combination of thermal cycling and constant-strain loading conditions.

C.2 Principle

A fusion-jointed fitting/pipe assembly initially conditioned at 60 °C, and with end caps fully constrained against movement due to thermal contraction, is subjected to 50 thermal cycles between + 60 °C and – 30 °C, – 15 °C or – 1 °C. Leaktightness is then verified at a temperature of (20 ± 3) °C.

NOTE The test is designed to assess by accelerated testing the effect on joint performance of annual fluctuations in operating temperature over the design life of the system (e.g. 50 years). The envisaged variations in operating temperature are as referenced in Clause 1 but the minimum equivalent test temperatures of – 30 °C (– 50 °C), – 15 °C (– 35 °C) and – 1 °C (– 20 °C) are selected to take account of the effect of a more rapid cycling of temperature on the thermal stresses generated in the test assembly.

C.3 Apparatus

C.3.1 End caps, of type a) construction as specified in ISO 1167-1. They shall be fully resistant to all end thrusts generated under the specified test conditions. They shall provide full restraint against movement induced by test piece contraction in the course of temperature cycling.

C.3.2 Temperature-conditioning chambers (two): environmental chambers each capable of controlling the operating temperature at the specified values (+ 60 °C and – 30 °C, – 15 °C or – 1 °C) to within a mean of – 1 °C to + 3 °C with a maximum deviation of – 2 °C to + 4 °C.

C.4 Test piece

The test piece shall comprise a fusion-jointed assembly of pipe(s) and fitting(s) in the as-manufactured condition, suitably end-capped for connection to a source of pneumatic pressure. The free lengths of pipe between fittings and end caps shall be three times the nominal pipe outside diameter, subject to a minimum of 250 mm and a maximum of 1 000 mm.

C.5 Procedure

Construct the test piece at an ambient temperature of (23 ± 3) °C using the manufacturer's recommended fusion-jointing conditions.

Carry out an assessment of test piece integrity in accordance with ISO 3458 at an ambient temperature of (23 ± 3) °C, using a hydrostatic pressure of 6 bar.

BS ISO 14531-2:2004

Depressurise and fully drain the water from the test piece, place the test piece in the high-temperature chamber and condition it for a period of 10 h at 60 °C. Fit the interconnecting end-cap-restraining system.

Carry out the following temperature-cycling procedure.

- a) Transfer the test piece to the low-temperature chamber and condition it for 10 h at – 30 °C, – 15 °C or – 1 °C, as appropriate. The minimum transfer time is 1,0 h and the maximum 2,0 h.
- b) Return the test piece to the high-temperature chamber and condition it for 10 h at + 60 °C. The minimum transfer time is 1,0 h and the maximum 2,0 h.
- c) Repeatedly cycle the test piece as specified in Table 5.
- d) Following completion of temperature cycling, subject the test piece to a leaktightness test in accordance with ISO 3458 at an ambient temperature of (23 ± 3) °C, using a hydrostatic pressure of 6 bar.

C.6 Test report

The test report shall include the following information:

- a) a reference to this part of ISO 14531, i.e. ISO 14531-2;
- b) full identification of the product, including manufacturer, type and size of fitting(s) and production date;
- c) the number of test pieces tested;
- d) the maximum and minimum test temperatures;
- e) the number of test cycles completed;
- f) a description of any visible evidence of failure;
- g) any factors which may have affected the results, such as any incidents or any operating details not specified in this part of ISO 14531;
- h) the date of the test.

Annex D (normative)

Validation of fitting design pressure DP_F

D.1 Scope

This annex specifies a method for the validation of the fitting design pressure DP_F declared by the fitting manufacturer and recorded in his technical file. The method relates to the conduct of long-term internal-pressure tests at 20 °C on test piece assemblies of pipes and fittings in which the free length(s) of pipes has been restricted to minimise the possibility of pipe failure in order to focus upon the failure characteristics of the fitting.

D.2 Principle

The method embraces two distinct features. The first is the generation and use of short-term fitting/joint failure data in conjunction with a theoretical (50 year) resistance to internal pressure strength requirement based on DP_F to establish a limit-line characteristic that defines the test times for further long-term pre-determined fixed-duration assembly tests. The second is the selection and application of a test pressure corresponding to a test time of 1 000 h on the basis of the limit-line characteristic. The satisfactory completion of the 1 000 h test period without premature failure of the test piece validates the declared DP_F . The conduct of the test is described schematically in Figure D.1.

D.3 Test piece

The test piece shall comprise a fusion-jointed assembly of pipes and fittings with fully end-load-bearing end caps for testing in accordance with ISO 9356. The free length of pipe between fittings and end caps shall not exceed $1d_e$.

D.4 Procedure

In accordance with ISO 12092, subject successive pipe/fitting test piece assemblies to an internal pressure greater than $1,05 \times K \times DP_F$ to produce at least five fitting/joint failures within periods greater than 100 h. Plot the failure data as log time vs log pressure and determine the average failure time and the corresponding standard deviation for the test data. The "no failure" limit line is then formed by a straight line drawn through a first point with the coordinates $1,05 \times K \times DP_F$ and the average failure time less two standard deviations and a second point with the coordinates $K \times DP_F$ and 50 years, as shown in Figure D.1.

NOTE The value of $K \times DP_F$ may be varied provided it is stated in the manufacturer's technical file, to permit comparison with the C -factor specified by the pipeline operator (see ISO 14531-4).

Using the limit line, select and apply the test pressure corresponding to a test period of 1 000 h. The DP_F shall be considered validated upon completion of the 1 000 h test without failure of the fusion-jointed fitting or a joint.

D.5 Test report

The test report shall include the following information;

- a) a reference to this part of ISO 14531, i.e. ISO 14531-2;
- b) full identification of the product, including manufacturer, type and size of fitting(s) and production date;
- c) the number of test pieces tested;
- d) the test pressure;
- e) the duration of the test;
- f) the DP_F multiple at 50 years;
- g) a description of any visible evidence of failure;
- h) any factors which may have affected the results, such as any incidents or any operating details not specified in this part of ISO 14531;
- i) the date of the test.

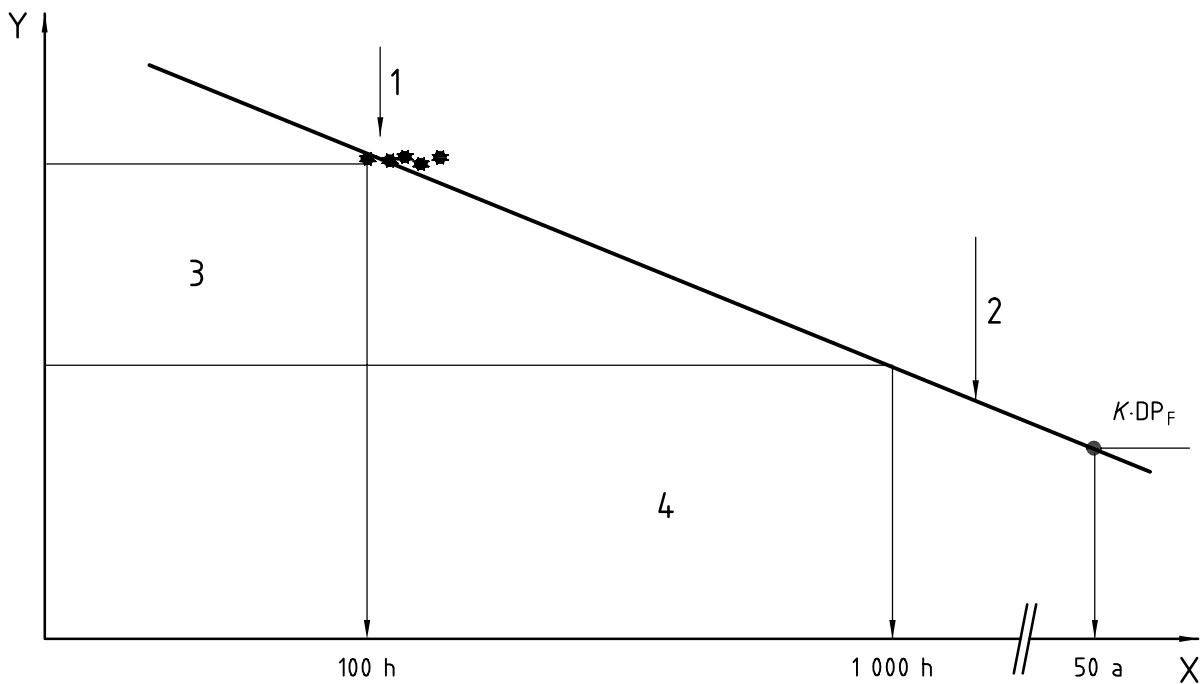

Key

- X log (time t)
- Y log (test pressure p_t)
- 1 fitting/joint failure points (minimum five)
- 2 limit line for “no failure” assembly tests
- 3 test pressure $\geq 1,05K \times DP_F$ to give failure periods of at least 100 h
- 4 test pressure to give limit-line test time of 1 000 h

Figure D.1 — Plot for DP_F validation test procedure

Bibliography

- [1] ISO 31-11, *Quantities and units — Part 11: Mathematical signs and symbols for use in the physical sciences and technology*
- [2] IEC 60335, *Household and similar appliances — Safety*
- [3] IEC 60364, *Electrical installations of buildings*
- [4] IEC 60449, *Voltage bands for electrical installations of buildings*

BSI — British Standards Institution

BSI is the independent national body responsible for preparing British Standards. It presents the UK view on standards in Europe and at the international level. It is incorporated by Royal Charter.

Revisions

British Standards are updated by amendment or revision. Users of British Standards should make sure that they possess the latest amendments or editions.

It is the constant aim of BSI to improve the quality of our products and services. We would be grateful if anyone finding an inaccuracy or ambiguity while using this British Standard would inform the Secretary of the technical committee responsible, the identity of which can be found on the inside front cover.
Tel: +44 (0)20 8996 9000. Fax: +44 (0)20 8996 7400.

BSI offers members an individual updating service called PLUS which ensures that subscribers automatically receive the latest editions of standards.

Buying standards

Orders for all BSI, international and foreign standards publications should be addressed to Customer Services. Tel: +44 (0)20 8996 9001.
Fax: +44 (0)20 8996 7001. Email: orders@bsi-global.com. Standards are also available from the BSI website at <http://www.bsi-global.com>.

In response to orders for international standards, it is BSI policy to supply the BSI implementation of those that have been published as British Standards, unless otherwise requested.

Information on standards

BSI provides a wide range of information on national, European and international standards through its Library and its Technical Help to Exporters Service. Various BSI electronic information services are also available which give details on all its products and services. Contact the Information Centre.
Tel: +44 (0)20 8996 7111. Fax: +44 (0)20 8996 7048. Email: info@bsi-global.com.

Subscribing members of BSI are kept up to date with standards developments and receive substantial discounts on the purchase price of standards. For details of these and other benefits contact Membership Administration.
Tel: +44 (0)20 8996 7002. Fax: +44 (0)20 8996 7001.
Email: membership@bsi-global.com.

Information regarding online access to British Standards via British Standards Online can be found at <http://www.bsi-global.com/bsonline>.

Further information about BSI is available on the BSI website at <http://www.bsi-global.com>.

Copyright

Copyright subsists in all BSI publications. BSI also holds the copyright, in the UK, of the publications of the international standardization bodies. Except as permitted under the Copyright, Designs and Patents Act 1988 no extract may be reproduced, stored in a retrieval system or transmitted in any form or by any means – electronic, photocopying, recording or otherwise – without prior written permission from BSI.

This does not preclude the free use, in the course of implementing the standard, of necessary details such as symbols, and size, type or grade designations. If these details are to be used for any other purpose than implementation then the prior written permission of BSI must be obtained.

Details and advice can be obtained from the Copyright & Licensing Manager.
Tel: +44 (0)20 8996 7070. Fax: +44 (0)20 8996 7553.
Email: copyright@bsi-global.com.