

# Optics and optical instruments — Test methods for telescopic systems —

## Part 4: Test methods for astronomical telescopes

ICS 37.020

## National foreword

This British Standard reproduces verbatim ISO 14490-4:2005 and implements it as the UK national standard.

The UK participation in its preparation was entrusted to Technical Committee CPW/172, Optics and optical instruments, which has the responsibility to:

- aid enquirers to understand the text;
- present to the responsible international/European committee any enquiries on the interpretation, or proposals for change, and keep UK interests informed;
- monitor related international and European developments and promulgate them in the UK.

A list of organizations represented on this committee can be obtained on request to its secretary.

### Cross-references

The British Standards which implement international publications referred to in this document may be found in the *BSI Catalogue* under the section entitled “International Standards Correspondence Index”, or by using the “Search” facility of the *BSI Electronic Catalogue* or of British Standards Online.

This publication does not purport to include all the necessary provisions of a contract. Users are responsible for its correct application.

**Compliance with a British Standard does not of itself confer immunity from legal obligations.**

### Summary of pages

This document comprises a front cover, an inside front cover, the ISO title page, pages ii and iii, a blank page, pages 1 to 8, an inside back cover and a back cover.

The BSI copyright notice displayed in this document indicates when the document was last issued.

### Amendments issued since publication

Amd. No.	Date	Comments

This British Standard was published under the authority of the Standards Policy and Strategy Committee on 12 January 2006

© BSI 12 January 2006

INTERNATIONAL  
STANDARD

**ISO**  
**14490-4**

First edition  
2005-11-01

---

---

**Optics and optical instruments — Test  
methods for telescopic systems —**

**Part 4:  
Test methods for astronomical  
telescopes**

*Optique et instruments d'optique — Méthodes d'essai pour systèmes  
télescopiques—*

*Partie 4: Méthodes d'essai pour télescopes astronomiques*



Reference number  
ISO 14490-4:2005(E)



## Foreword

ISO (the International Organization for Standardization) is a worldwide federation of national standards bodies (ISO member bodies). The work of preparing International Standards is normally carried out through ISO technical committees. Each member body interested in a subject for which a technical committee has been established has the right to be represented on that committee. International organizations, governmental and non-governmental, in liaison with ISO, also take part in the work. ISO collaborates closely with the International Electrotechnical Commission (IEC) on all matters of electrotechnical standardization.

International Standards are drafted in accordance with the rules given in the ISO/IEC Directives, Part 2.

The main task of technical committees is to prepare International Standards. Draft International Standards adopted by the technical committees are circulated to the member bodies for voting. Publication as an International Standard requires approval by at least 75 % of the member bodies casting a vote.

Attention is drawn to the possibility that some of the elements of this document may be the subject of patent rights. ISO shall not be held responsible for identifying any or all such patent rights.

ISO 14490-4 was prepared by Technical Committee ISO/TC 172, *Optics and photonics*, Subcommittee SC 4, *Telescopic systems*.

ISO 14490 consists of the following parts, under the general title *Optics and optical instruments — Test methods for telescopic systems*:

- *Part 1: Test methods for basic characteristics*
- *Part 2: Test methods for binocular systems*
- *Part 3: Test methods for telescopic sights*
- *Part 4: Test methods for astronomical telescopes*
- *Part 5: Test methods for transmittance*
- *Part 6: Test methods for veiling glare index*
- *Part 7: Test methods for limit of resolution*

The following part is under preparation:

- *Part 8: Test methods for night-vision devices*



# Optics and optical instruments — Test methods for telescopic systems —

## Part 4: Test methods for astronomical telescopes

### 1 Scope

This part of ISO 14490 is applicable to amateur astronomical telescopes.

For general optical test methods of telescopic systems see ISO 14490-1.

### 2 Normative references

The following referenced documents are indispensable for the application of this document. For dated references, only the edition cited applies. For undated references, the latest edition of the referenced document (including any amendments) applies.

ISO 8596, *Ophthalmic optics — Visual acuity testing — Standard optotype and its presentation*

ISO 14132-1:2002, *Optics and optical instruments — Vocabulary for telescopic systems — Part 1: General terms and alphabetical indexes of terms in ISO 14132*

ISO 14132-4:2002, *Optics and optical instruments — Vocabulary for telescopic systems — Part 4: Terms for astronomical telescopes*

ISO 14490-1:2005, *Optics and optical instruments — Test methods for telescopic systems — Part 1: Test methods for basic characteristics*

### 3 Terms and definitions

For the purposes of this document, the terms and definitions given in ISO 14132-1 and ISO 14132-4 apply.

### 4 Optical test methods for astronomical telescopes

Typical test methods are shown here, and other similar methods are acceptable.

#### 4.1 Clear aperture of objective

The clear aperture of the objective shall be measured by one of the following methods.

- a) Measure the unobstructed diameter of the objective lens of refracting telescopes and finder telescopes or that of the main mirror of reflecting telescopes by means of an appropriate linear measuring instrument.
- b) Set the focus of the optical system of the telescope or finder telescope to infinity using a dioptric tester. Set a bundle of parallel rays at zero incidence angle using a collimator on the eyepiece side, project the exit bundle of rays from the objective onto a screen perpendicular to the optical axis and measure its diameter.

- c) Using a piece of ground glass let diffuse light be incident on the eyepiece side of the telescope or the finder telescope, and measure the minimum value of the aperture of the objective by using a travelling microscope parallel to the optical axis in object space, which can be moved across the diameter of the objective.

## 4.2 Focal lengths of objective and eyepiece

The test methods for the focal lengths of objective and eyepiece shall be as given in 4.2.1 or 4.2.2.

### 4.2.1 Focal length of objective lens and eyepiece (nodal slide method)

Refer to Figure 1. Arrange the rotary table (item 8 in Figure 1) (nodal slide stand), so that the axis of rotation is perpendicular to the optical axis of the collimator lens (item 3) on an optical bench (item 6). Place a reticle (item 2) at the focal plane of the collimator. On the rotary table, a slide stand (item 7) is moving in the direction of the optical axis of the microscope (item 5), which has its optical axis approximately coinciding with that of the collimator. Measure the focal length  $f$  in accordance with 4.2.1.1 to 4.2.1.3.

**4.2.1.1** Install the alignment reticle (item 4 in Figure 1) on the slide stand (item 7) so that the alignment reticle (item 4) coincides with the axis of the rotation of the rotary table (item 8), as shown in Figure 1 a). While adjusting the microscope (item 5) so that the reticle (item 4) can be seen clearly, read out the position of the microscope on the optical bench (item 6) and stop when the position of the reticle (item 4) is such that, when it is slightly rotated about its vertical axis, there is no lateral movement of the image.

**4.2.1.2** Remove the alignment reticle (item 4) and mount the objective lens (item 9) under test on the slide stand (item 7) in front of the collimator. Adjust the microscope (item 5) until the sharp image of the collimator reticle (item 2) formed by the lens under test can be seen clearly. Set the rear nodal plane of the lens under test to coincide with the axis of rotation of the rotary table (item 8), as shown in Figure 1 b), i.e. when the rotary table is slightly rotated about its vertical axis, the image of the collimator reticle is stationary. Read out the new position of the microscope on the optical bench.

**4.2.1.3** The equivalent focal length  $f$  of the objective lens to be measured is the difference between the positions of the microscope in 4.2.1.1 and 4.2.1.2.

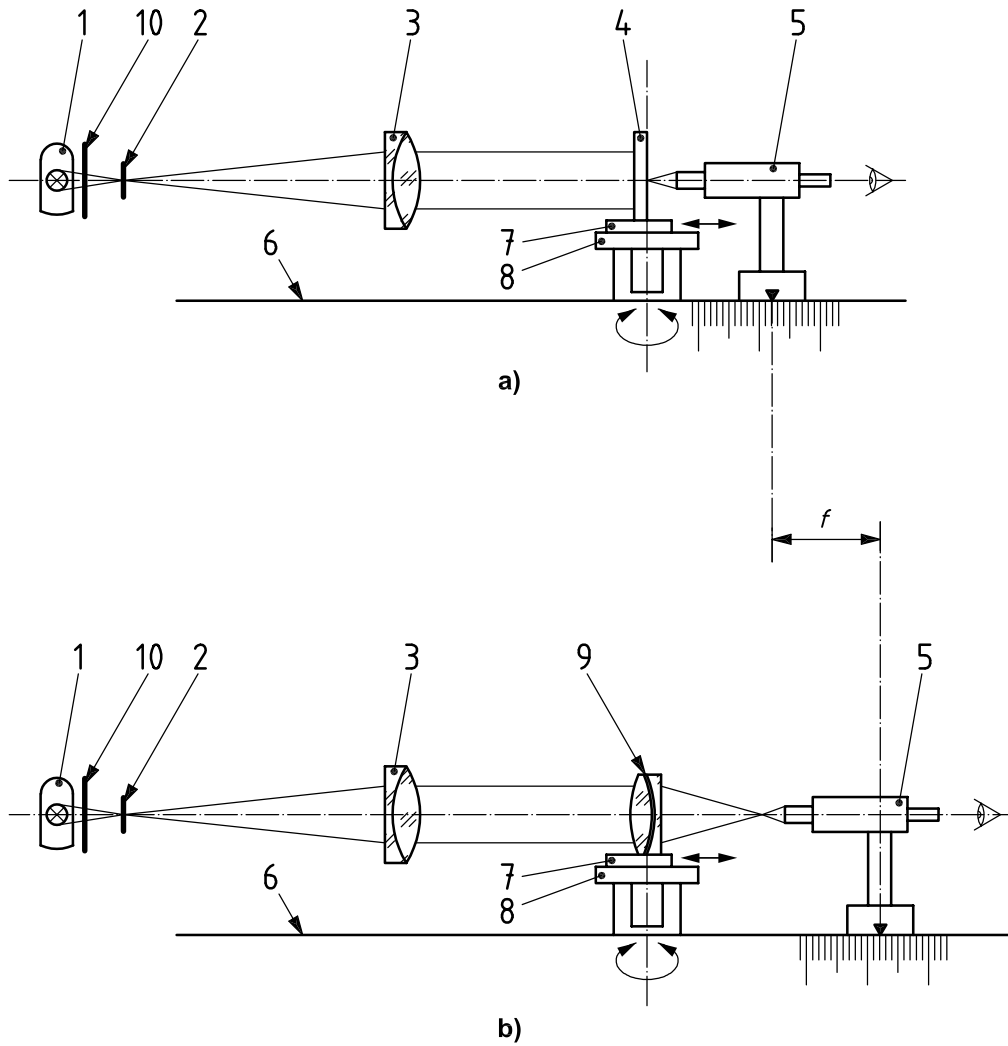

**Key**

- 1 light source
  - 2 collimator reticle
  - 3 collimator lens
  - 4 alignment reticle
  - 5 microscope with numerical aperture 0,1 or higher
  - 6 optical bench
  - 7 slide stand
  - 8 rotary table
  - 9 objective lens or eyepiece under test
  - 10 green filter (max. transmittance about 0,55  $\mu\text{m}$ )
- $f$  focal length

**Figure 1 — Measurement of the focal lengths of objective lens or eyepiece**

#### 4.2.2 Focal length of objective mirror (method using a microscope with illuminator)

The test method described below does not apply to objective mirrors with central obscuration.

Let the axis of rotation of the rotary table be perpendicular to the optical axis and lie in the same plane as the optical axis of the microscope with illuminator (item 3) as shown in Figure 2, and measure in accordance with the following procedures.

The rotating mechanism of the rotary table shall be used for alignment of the optical axis of the objective mirror (item 2) under test with that of a microscope with illuminator.

Let the axis of rotation of the rotary table be perpendicular to the optical axis and lie in the same plane as the optical axis of the microscope with illuminator and place the reticle (item 5) in the object plane of the microscope, parallel to the axis of rotation.

**4.2.2.1** As shown in Figure 2 a), mount the objective mirror to be measured on the rotary table in front of the microscope with illuminator.

**4.2.2.2** Move the microscope with illuminator to the position where the image of the reticle can be seen clearly and read out its position  $a$  on the optical bench.

**4.2.2.3** Next, read out the position  $b$  of the microscope with illuminator on the optical bench, where the image of the reticle, which has been reflected at the centre of the objective mirror, can be seen clearly, as in Figure 2 b).

**4.2.2.4** The focal length of the objective mirror to be measured is equal to half the difference between the readings of the positions of the microscope with illuminator in positions 4.2.2.2 and 4.2.2.3, (e.g.  $0,5 | a - b |$ ).

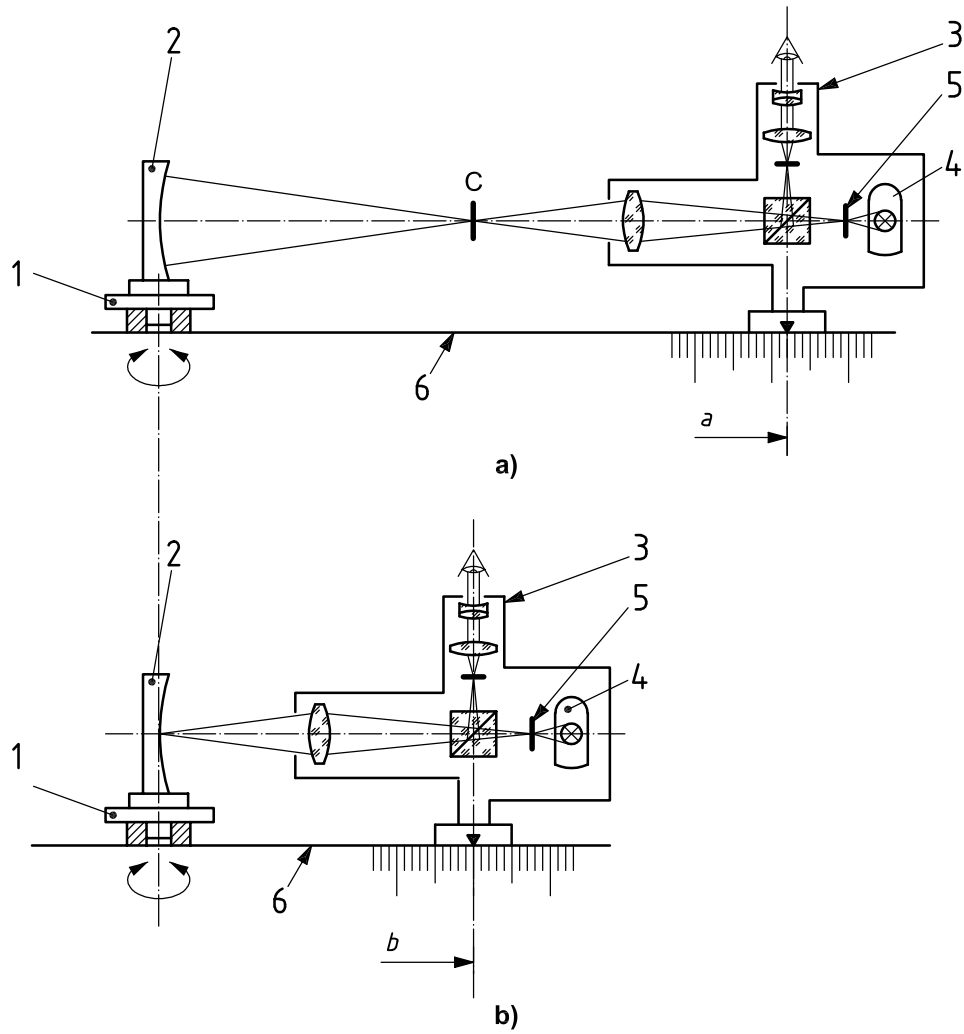

**Key**

- 1 rotary table
- 2 mirror under test
- 3 microscope having the numerical aperture 0,1 or higher, with illuminator
- 4 light source
- 5 reticle
- 6 optical bench
- C centre of curvature of the mirror under test

**Figure 2 — Measurement of focal length of objective mirror**

**4.3 Resolution**

The resolution shall be measured by the following method.

**4.3.1 Resolution of main telescope**

For measurement of the resolution of the telescope, a well-designed eyepiece should be used by a person with good eyesight (compensated visual acuity of 1,0 or over, measured in accordance with ISO 8596).

A test target with two pinholes should be observed through a collimator.

The separation between the two pinholes in the target should be in accordance with the Rayleigh criterion defined in ISO 14132-4, taking into account the focal length of the collimator and of the instrument under test.

The resolution is determined when the images of the two pinholes are observed as just resolved.

Use an excellent, well-designed eyepiece for measurement with an exit pupil diameter of 0,5 mm.

A test target of double pinholes shall be as shown in Figure 3.

In order to maintain accuracy, the diameter  $d$  of the test pinholes relative to their separation  $s$  should be small,  $d \leq 0,5 s$ .

It is recommended that the focal length of the collimator objective for testing the main telescope and finder telescope be greater than 2 000 mm.

It is recommended to measure and state the usable image plane diameter of the objective alone to where the resolution drops twice to axial.

**4.3.2 Resolution of finder telescope**

Refer to ISO 14490-7 for the measuring method of the resolution for the finder.

Values in seconds of arc

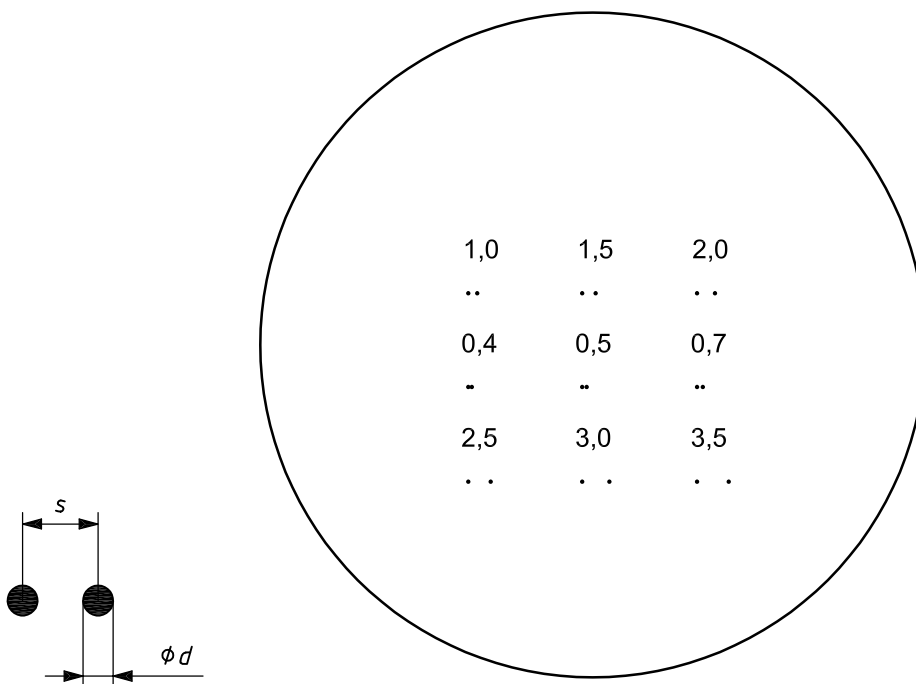

$d_{min} = 0,002 \text{ mm}$

Licensed copy: Istanbul Teknik Üniversitesi, Istanbul Teknik Üniversitesi, Version correct as of 27/08/2015

Pinhole separations of test target (collimator focal length: 2 500 mm)	
Seconds of arc	<i>s</i> mm
0,4	0,005
0,5	0,006
0,7	0,008
1,0	0,012
1,5	0,018
2,0	0,024
2,5	0,030
3,0	0,036
3,5	0,042

Figure 3 — Test target and example of resolution test of main telescope

## 5 Test report

A test report shall be presented including the test results and the following information:

- a) test method;
- b) date of test;
- c) identification of the test specimen;
- d) details about the test arrangement and/or procedure, if required and/or if different from those specified in this part of ISO 14490;
- e) reference to this part of ISO 14490, i.e. ISO 14490-4:2005;
- f) name of the test laboratory;
- g) name of the examiner.

## Bibliography

- [1] ISO 14490-7, *Optics and optical instruments — Test methods for telescopic systems — Part 7: Test methods for limit of resolution*



---

---

## BSI — British Standards Institution

BSI is the independent national body responsible for preparing British Standards. It presents the UK view on standards in Europe and at the international level. It is incorporated by Royal Charter.

### Revisions

British Standards are updated by amendment or revision. Users of British Standards should make sure that they possess the latest amendments or editions.

It is the constant aim of BSI to improve the quality of our products and services. We would be grateful if anyone finding an inaccuracy or ambiguity while using this British Standard would inform the Secretary of the technical committee responsible, the identity of which can be found on the inside front cover.  
Tel: +44 (0)20 8996 9000. Fax: +44 (0)20 8996 7400.

BSI offers members an individual updating service called PLUS which ensures that subscribers automatically receive the latest editions of standards.

### Buying standards

Orders for all BSI, international and foreign standards publications should be addressed to Customer Services. Tel: +44 (0)20 8996 9001.  
Fax: +44 (0)20 8996 7001. Email: [orders@bsi-global.com](mailto:orders@bsi-global.com). Standards are also available from the BSI website at <http://www.bsi-global.com>.

In response to orders for international standards, it is BSI policy to supply the BSI implementation of those that have been published as British Standards, unless otherwise requested.

### Information on standards

BSI provides a wide range of information on national, European and international standards through its Library and its Technical Help to Exporters Service. Various BSI electronic information services are also available which give details on all its products and services. Contact the Information Centre.  
Tel: +44 (0)20 8996 7111. Fax: +44 (0)20 8996 7048. Email: [info@bsi-global.com](mailto:info@bsi-global.com).

Subscribing members of BSI are kept up to date with standards developments and receive substantial discounts on the purchase price of standards. For details of these and other benefits contact Membership Administration.  
Tel: +44 (0)20 8996 7002. Fax: +44 (0)20 8996 7001.  
Email: [membership@bsi-global.com](mailto:membership@bsi-global.com).

Information regarding online access to British Standards via British Standards Online can be found at <http://www.bsi-global.com/bsonline>.

Further information about BSI is available on the BSI website at <http://www.bsi-global.com>.

### Copyright

Copyright subsists in all BSI publications. BSI also holds the copyright, in the UK, of the publications of the international standardization bodies. Except as permitted under the Copyright, Designs and Patents Act 1988 no extract may be reproduced, stored in a retrieval system or transmitted in any form or by any means – electronic, photocopying, recording or otherwise – without prior written permission from BSI.

This does not preclude the free use, in the course of implementing the standard, of necessary details such as symbols, and size, type or grade designations. If these details are to be used for any other purpose than implementation then the prior written permission of BSI must be obtained.

Details and advice can be obtained from the Copyright & Licensing Manager.  
Tel: +44 (0)20 8996 7070. Fax: +44 (0)20 8996 7553.  
Email: [copyright@bsi-global.com](mailto:copyright@bsi-global.com).