



BSI Standards Publication

**Workplace atmospheres —
Determination of toluene
diisocyanate vapours using
1-(2-pyridyl) piperazine-
coated glass fibre filters and
analysis by high performance
liquid chromatography
with ultraviolet and
fluorescence detectors**

National foreword

This British Standard is the UK implementation of ISO 14382:2012.

The UK participation in its preparation was entrusted to Technical Committee EH/2/2, Work place atmospheres.

A list of organizations represented on this committee can be obtained on request to its secretary.

This publication does not purport to include all the necessary provisions of a contract. Users are responsible for its correct application.

© The British Standards Institution 2012.
Published by BSI Standards Limited 2012.

ISBN 978 0 580 69759 3

ICS 13.040.30

Compliance with a British Standard cannot confer immunity from legal obligations.

This British Standard was published under the authority of the Standards Policy and Strategy Committee on 31 December 2012.

Amendments issued since publication

Date	Text affected
------	---------------

**Workplace atmospheres —
Determination of toluene diisocyanate
vapours using 1-(2-pyridyl)
piperazine-coated glass fibre filters
and analysis by high performance
liquid chromatography with
ultraviolet and fluorescence detectors**

Air des lieux de travail — Détermination des vapeurs de toluène diisocyanate à l'aide de filtres en fibre de verre enduits de pipérazine-1-(2-pyridyl) et par analyse par chromatographie liquide à haute performance avec détecteurs à ultraviolets et à fluorescence





COPYRIGHT PROTECTED DOCUMENT

© ISO 2012

All rights reserved. Unless otherwise specified, no part of this publication may be reproduced or utilized in any form or by any means, electronic or mechanical, including photocopying and microfilm, without permission in writing from either ISO at the address below or ISO's member body in the country of the requester.

ISO copyright office
Case postale 56 • CH-1211 Geneva 20
Tel. + 41 22 749 01 11
Fax + 41 22 749 09 47
E-mail copyright@iso.org
Web www.iso.org

Published in Switzerland

Contents

Page

Foreword	iv
Introduction	v
1 Scope	1
2 Normative references	1
3 Principle	1
4 Reagents and materials	2
5 Reagent solutions	2
5.1 Preparation of TDI urea derivatives.....	2
5.2 Analytical standards.....	2
5.3 Filter extraction solution.....	3
5.4 1-2PP filter coating solution.....	3
5.5 HPLC mobile phase.....	3
6 Apparatus	3
6.1 Air sampler.....	3
6.2 Sampling pump.....	4
6.3 Sampling pump calibration.....	4
6.4 Tubing.....	4
6.5 Flowmeter.....	4
6.6 Liquid chromatography system.....	4
7 Air sampling	5
7.1 Calibration of sampling pump.....	5
7.2 Safety practices.....	5
7.3 Preparation of air sampler.....	5
7.4 Collection of air samples.....	5
7.5 Blanks.....	5
7.6 Sample shipment.....	5
8 HPLC analysis	6
8.1 Safety precautions.....	6
8.2 Sample preparation.....	6
8.3 Standards preparation.....	6
8.4 HPLC conditions.....	6
9 Analysis	7
9.1 Calibration.....	7
10 Quality control	7
11 Sample quantification	7
11.1 Determination of TDI mass per sample.....	7
11.2 Determination of TDI mass concentration in air.....	8
11.3 Determination of TDI volume fraction in air.....	8
12 Interferences	8
13 Determination of performance characteristics	9
13.1 Introduction.....	9
13.2 Relevant uncertainty contributions and criteria.....	10
13.3 Assessment of performance characteristics (ISO GUM approach).....	10
Annex A (informative) Performance characteristics	18
Bibliography	20

Foreword

ISO (the International Organization for Standardization) is a worldwide federation of national standards bodies (ISO member bodies). The work of preparing International Standards is normally carried out through ISO technical committees. Each member body interested in a subject for which a technical committee has been established has the right to be represented on that committee. International organizations, governmental and non-governmental, in liaison with ISO, also take part in the work. ISO collaborates closely with the International Electrotechnical Commission (IEC) on all matters of electrotechnical standardization.

International Standards are drafted in accordance with the rules given in the ISO/IEC Directives, Part 2.

The main task of technical committees is to prepare International Standards. Draft International Standards adopted by the technical committees are circulated to the member bodies for voting. Publication as an International Standard requires approval by at least 75 % of the member bodies casting a vote.

Attention is drawn to the possibility that some of the elements of this document may be the subject of patent rights. ISO shall not be held responsible for identifying any or all such patent rights.

ISO 14382 was prepared by Technical Committee ISO/TC 146, *Air quality*, Subcommittee SC 2, *Workplace atmospheres*.

Introduction

The most common form of toluene diisocyanate (TDI) marketed commercially is a mixture containing 80 % 2,4-TDI and 20 % 2,6-TDI. It is also available as a mixture containing 65 % 2,4-TDI and 35 % 2,6-TDI, and as the pure 2,4-TDI isomer. The main commercial use for TDI is the manufacture of polyurethane (PU) flexible foams used in upholstery, mattresses, shoe soles, and automotive seats. The PU foams are prepared by reacting the TDI with a polyol to produce the product. Depending on the components selected and how they are combined, end products with quite different properties can be achieved.

The majority of flexible foams are produced by the slabstock foaming process, in which the mixture of polyurethane raw materials is dispensed onto paper linings in an open trough, where it gradually expands into a large bun of foam. These buns are cut into blocks or slices, which are then processed into the final desired products.

In the majority of workplace atmospheres, TDI is present as a vapour and the 2,6-isomer may be predominant. In those rare instances where TDI is emitted into workplace environments as an aerosol, the aerosols are collected efficiently by the glass fibre filter. The TDI in the aerosol readily evaporates during sampling and is captured by the liquid reagent [1-(2-pyridyl)piperazine] coated on the filter. This International Standard provides a simple, well-tested and reliable method for the sampling and analysis of TDI using instrumentation readily available in most commercial laboratories. This International Standard is based on the United States Occupational Safety and Health Administration (OSHA) Method 42^[9] for diisocyanates, ASTM D5836^[8] (which is based on the OSHA Method 42^[9]) and on modifications to OSHA Method 42^[9] recommended by Bayer MaterialScience Environmental Analytics Laboratory^[10]. The Bayer modifications include the use of 2 mg of reagent to coat the sampling filter and the use of cellulose spacer rings in the air sampling cassette.

OSHA Method 42 is widely used throughout the world. In an interlaboratory evaluation of the ASTM D5836^[8] with 13 participating laboratories, the average recovery from spiked media for 2,4-TDI was $(106 \pm 5,6)$ % and $(104 \pm 5,7)$ % for 2,6-TDI. Laboratory precision, measured as a repeatability coefficient of variation, was 6,2 % for 2,4-TDI and 5,7 % for 2,6-TDI.

Workplace atmospheres — Determination of toluene diisocyanate vapours using 1-(2-pyridyl)piperazine-coated glass fibre filters and analysis by high performance liquid chromatography with ultraviolet and fluorescence detectors

WARNING — This document does not purport to address all safety concerns, if any, associated with its use. It is the responsibility of the user of this document to establish appropriate health and safety practices and to determine the application of regulatory limitations prior to use.

1 Scope

This International Standard gives general guidance for the sampling and analysis of airborne toluene diisocyanate (TDI) in workplace atmospheres. The procedure specified in this International Standard is especially suitable for short (15 min) and long-term (4 h) sampling and analysis of 2,4- and 2,6-TDI vapours.

The upper limit for this method is approximately 85 µg of TDI per sample. This is a conservative upper limit based on the requirement of maintaining a sufficient amount of reagent on the coated glass fibre filter while permitting a 4 h sample to be collected at 1 l/min from an atmosphere containing 50 nl/l of TDI.

The quantitation limits for this method are 0,039 µg for 2,4-TDI and 0,034 µg for 2,6-TDI using a fluorescence detector. These limits, for a 15-min sample collected at 1 l/min, are equivalent to 0,36 nl/l for 2,4-TDI, and 0,32 nl/l for 2,6-TDI. For a 4 h sample collected at 1 l/min, the limits are equivalent to 0,022 nl/l for 2,4-TDI and 0,020 nl/l for 2,6-TDI.

The commercial availability of the specified reagents, the use of common analytical instrumentation, and the current widespread use of the method make this standard method ideally suited for the determination of TDI in workplace environments.

2 Normative references

The following documents, in whole or in part, are normatively referenced in this document and are indispensable for its application. For dated references, only the edition cited applies. For undated references, the latest edition of the referenced document (including any amendments) applies.

ISO 5725-2, *Accuracy (trueness and precision) of measurement methods and results — Part 2: Basic method for the determination of repeatability and reproducibility of a standard measurement method*

ISO 16200-1, *Workplace air quality — Sampling and analysis of volatile organic compounds by solvent desorption/gas chromatography — Part 1: Pumped sampling method*

3 Principle

Samples are collected by drawing a known volume of workplace air through glass fibre filters coated with 2 mg of 1-(2-pyridyl)piperazine (1-2PP) which are contained in open-face cassettes. Samples are collected at 1 l/min for 15 min; up to a maximum sampling time of 4 h. Bayer^[10] has methods that use both 13 mm and 37 mm filters (both sizes are coated with 2 mg of 1-2PP), but OSHA Method 42^[9] uses only 37 mm filters. The Bayer 13 mm filters are coated with 5 µl of diethylphthalate per filter in addition to 2 mg of 1-2PP. The samples are extracted with 90 + 10 parts by volume acetonitrile/dimethyl sulfoxide (90 + 10 parts by volume ACN + DMSO) and are analysed by high performance liquid chromatography (HPLC) using an ultraviolet (UV) or a fluorescence detector. Use of both detectors in series allows the analyst to have high confidence in HPLC peak identification and quantitation. Other mixture ratios of ACN + DMSO can be used, providing they are tested and their use is consistent throughout the analysis.

4 Reagents and materials

Use only reagents of recognized analytical grade, unless otherwise specified. Always evaluate the derivatization and/or chromatographic effects when a reagent is changed.

- 4.1 **Methylene chloride** [CAS 75-0-2], HPLC grade.
- 4.2 **Hexane** [CAS 110-54-3], HPLC grade.
- 4.3 **Acetonitrile (ACN)** [CAS 75-05-8], HPLC grade.
- 4.4 **Dimethyl sulfoxide (DMSO)** [CAS 67-68-5], HPLC grade.
- 4.5 **Water** [CAS 7732-18-5], HPLC grade.
- 4.6 **1-(2-Pyridyl)piperazine** [CAS 34803-66-2], ≥99,5 % (mass fraction) grade.
- 4.7 **2,4-TDI** [CAS 584-84-9].
- 4.8 **2,6-TDI** [CAS 91-08-7].
- 4.9 **Ammonium acetate** [CAS 631-61-8], HPLC grade.
- 4.10 **Acetic acid, glacial** [CAS 64-19-7], HPLC grade.
- 4.11 **Acetone** [CAS 67-64-1], HPLC grade.

5 Reagent solutions

5.1 Preparation of TDI urea derivatives

Prepare a solution containing 3,5 g of 2,4-TDI in 25 ml of methylene chloride and slowly add it to a stirred solution of 7,25 g of 1-2PP in 100 mL of methylene chloride. Slowly heat the solution to about 35°C, stirring constantly for several minutes. Reduce the volume of methylene chloride to about 10 ml with a stream of dry nitrogen. Precipitate the product by slowly adding approximately 50 ml of hexane to the solution (precipitation may start without adding the hexane). Filter the precipitate and then redissolve it in a minimal volume of methylene chloride and reprecipitate. Filter the solution and wash the collected precipitate with hexane. The approximate yield is 9 g of the derivative after being dried by a vacuum. This preparation is a modification of the procedure reported by Goldberg et al.^[11]. The purity of the TDI urea shall be checked using the melting point, elemental analysis, and/or NMR spectroscopy. The solid urea, when stored in a well-sealed dark bottle, is stable for more than 10 years. The 1-2PP derivative of 2,6-TDI is prepared by a similar procedure.

5.2 Analytical standards

5.2.1 Preparation of analytical standards using TDI urea derivatives

Stock analytical standard solutions are prepared by accurately weighing (to three significant figures) the TDI urea derivatives (5.1) and then dissolving them in DMSO. To express the derivative as free TDI,

weigh the amount of 2,4-TDI and 2,6-TDI ureas and multiply by the conversion factor of 0,3479, the ratio of molecular masses.

$$\frac{M_r(\text{TDI})}{M_r(\text{TDI urea})} = \frac{174,6}{500,1} = 0,3479$$

All dilutions of the stock solutions are made to arrive at the working range in 90 + 10 parts by volume ACN + DMSO. For example, a stock standard prepared in DMSO can be diluted 1→10 with pure ACN to arrive at 90 + 10 parts by volume ACN + DMSO. Any further dilutions are made with 90 + 10 parts by volume ACN + DMSO.

5.2.2 Preparation of analytical standards using pure TDI

Analytical standard solutions can also be prepared by reacting TDI (either pure 2,4-TDI or pure 2,6-TDI isomer) with 1-2PP in solution. Prepare a solution containing 1 mg/ml (0,006 mmol/l) 1-2PP by diluting 100 mg of 1-2PP to the mark with 90 + 10 parts by volume ACN + DMSO in a 100 ml volumetric flask, ISO 1042,^[1] class A. Prepare a separate solution of 1 mg/ml (0,006 mmol/l) pure TDI by carefully and accurately weighing 50 mg of TDI (to three significant figures) and diluting it to the mark with 90 + 10 parts by volume ACN + DMSO in a 50 ml volumetric flask. Pipette 1 ml to 3 ml of the 1 mg/ml TDI solution into a 25 ml volumetric flask and dilute to the mark with the 1 mg/ml 1-2PP solution. Mix the solution well and allow it to react overnight. Do not use more than 3 ml of the TDI solution in order to ensure a proper excess of 1-2PP. Do *not* use the conversion factor in 5.2.1 to calculate the concentration of these standards. Use fresh solutions. The amount of pure TDI isomer shall be accurately known to prepare accurate standards.

5.2.3 Commercial standard solutions

Analytical standard solutions are commercially available.

5.3 Filter extraction solution

This solution is composed of 90 + 10 parts by volume ACN + DMSO.

5.4 1-2PP filter coating solution

This solution is composed of 4 mg/ml (0,025 mmol/l) 1-2PP in methylene chloride.

5.5 HPLC mobile phase

This solution is composed of 0,01 M ammonium acetate (buffered to pH 6,2 with acetic acid) in water and acetonitrile. The exact composition of the mobile phase depends on the HPLC column selected for use. The buffered ammonium acetate solution can be prepared separately and used in a solvent programmed gradient with acetonitrile.

6 Apparatus

6.1 Air sampler

The air sampler consists of a three piece 37 mm polystyrene cassette with a glass fibre filter (type A/E binder free) coated with 2 mg of 1-2PP (see Figure 1).

6.1.1 Preparation of coated filters

Prepare a sufficient volume of a solution containing 4 mg/ml 1-2PP in methylene chloride. The volume is based on the number of filters to be coated. Use 0,5 ml of this solution to coat each filter. Use a properly functioning fume hood to evaporate the solvent and minimize exposure of the filters to light during coating, drying, and subsequent operations. Separately place the uncoated glass fibre filters on a

nickel-chromium wire grid or on the rims of 40 ml glass beakers so that only the edges of the filter are supported. Carefully, and slowly, pipette 0,5 ml of the 1-2PP solution onto the centre of the filter. This volume of solution is sufficient to fully wet the filter. Allow the methylene chloride solvent to evaporate in the hood for about 1 h. Transfer the coated filters to a clean dry container, loosely cap the container, and place the container in a vacuum desiccator equipped with a cold trap. Further dry the filters at reduced pressure for about 2 h. Analyse at least three of the coated filters for TDI after they are dry and store the remaining filters in a closed container in a freezer at $-20\text{ }^{\circ}\text{C}$. There are various recommendations for the shelf life of these filters, however, they have been successfully used for up to 1 year after preparation when stored in a freezer until use. Do not store isocyanates, anhydrides, alcohols, carboxylic acids, or amines in the same freezer.

6.1.2 Commercial coated filters

Glass fibre filters coated with 1-2PP are commercially available; however, the amount of 1-2PP coated on the filter may be different than specified in this International Standard.

6.1.3 Assembly of sampling cassettes

Store the coated filters and assembled cassettes in a freezer. Do not store isocyanates, anhydrides, alcohols, carboxylic acids, or amines in the same freezer.

Try to anticipate sampling needs and to minimize storage time for assembled sampling cassettes.

Place a cellulose spacer ring on the cassette bottom, then put a coated filter on top of the spacer ring, and place a cassette ring on top of the coated filter. Use sufficient pressure to completely seal the assembled sampling cassette. Seal the cassette with a shrink band. Sampling is performed with an open-face cassette; therefore, the cassette top need not be firmly attached to the sampler unless the assembled sampler is to be stored where it could become contaminated or if it is to be stored for more than 1 day or 2 days before use.

6.2 Sampling pump

The pump shall fulfil the requirements of EN 1232^[5] or equivalent. The sampling pump shall be capable of maintaining a flow rate of $(1,00 \pm 0,05)$ l/min with the air sampler in-line.

6.3 Sampling pump calibration

Calibrate the sampling pump with a representative air sampling cassette in-line using a calibrated external flowmeter that is accurate to within $\pm 2\%$.

6.4 Tubing

Use about 90 cm of flexible plastic tubing to connect the sampling cassette to the sampling pump. Clips shall be provided to secure the sampler and the tubing to the wearer's lapel within their breathing zone.

6.5 Flowmeter

Use a portable calibrated flowmeter, capable of measuring 1,00 l/min to within $\pm 0,05$ l/min with the air sampling cassette in-line, to check the flow rate. The flowmeter is not the principal calibration device.

6.6 Liquid chromatography system

6.6.1 HPLC system

An HPLC system consisting of an autosampler, a column oven, an HPLC pumping system capable of gradient elution, a fluorescence detector, and/or an ultraviolet detector, is required for the analysis of samples. A computerized data system is useful to acquire and reduce data.

6.6.2 HPLC analytical column

There are many excellent C-8 and C-18 HPLC columns that are capable of separating 2,4- and 2,6-TDI isomers from potential interferences. The selected analytical column can be operated with an appropriate guard column. Use of a guard column is optional.

6.6.3 Syringes and syringe filters

Use disposable syringes and 0.2 µm pore size PTFE syringe filters that are both compatible with ACN + DMSO mixtures to filter sample solutions.

7 Air sampling

7.1 Calibration of sampling pump

Calibrate each sampling pump with a representative sampling filter cassette in-line to $(1 \pm 0,05)$ l/min using a certified flowmeter traceable to national standards. Pump calibration shall be performed before sampling and shall be verified after sampling. The sampling rates shall agree to within 5 % or the sample is invalid. Use the same type sampler but not the same samplers that are intended to be used for air sampling to calibrate the sampling pumps.

7.2 Safety practices

Follow all safety practices that apply to the workplace being sampled. The sampling equipment shall be attached to the wearer in such a manner that it does not interfere with work performance or safety.

7.3 Preparation of air sampler

Remove the cassette top piece for open-face sampling. Remove the cassette bottom plug and connect the air sampler to the flexible plastic tubing with a Luer fitting. Minimize exposure of the sampling filter to light. Connect the calibrated sampling pump to the flexible plastic tubing and an air sampler. Use the portable calibrated flowmeter to check the flow rate.

7.4 Collection of air samples

In an isocyanate-free location, using the supplied clips, attach the open-face air sampler and tubing to the wearer's lapel in their breathing zone with the open-face down. Attach the sampling pump to the wearer's belt or to another secure location. When ready to begin sampling, turn on the sampling pump and record the start time. Collect samples at 1 l/min for 15 min; up to a maximum sampling time of 4 h. Take two consecutive samples for 4 h each for 8 h time-weighted average measurements. Minimize exposure of the sampling filter to light. After sampling is complete, record the stop time, turn off the sampling pump, and remove the sampling equipment from the wearer. Replace the cassette top and bottom end plug. Store the collected sample at ambient temperature in the dark for up to six days. Store the collected samples in a freezer at -20 °C, if they are not analysed within 6 days. Accurately determine and record the temperature and atmospheric pressure at the sampling site. If TDI aerosols are present, it may be advisable to extract collected samples in the field by following the instructions in 8.2.

7.5 Blanks

Submit at least one blank per 10 air samples. Blank air samplers shall be handled identically to the actual air samples, except that no air is drawn through them.

7.6 Sample shipment

Ship the collected air samples and the blank air samplers to the analytical laboratory as soon as possible by overnight delivery. If delay is unavoidable, store the air samples and blanks in an isocyanate-free

refrigerator. Do not ship air samples and blanks with bulk samples. Identify potential interferences on the accompanying paperwork. Follow sample shipment restrictions and precautions in regards to extraction solvents when samples are extracted in the field and shipped to the analytical laboratory.

8 HPLC analysis

8.1 Safety precautions

The analyst shall wear safety glasses, appropriate disposable gloves, and a lab coat during analysis as a precaution against exposure to solvents and reagents.

8.2 Sample preparation

Transfer the sample and blank filters to separate 4 ml glass vials so that the filters are flat against the inside surface of the vials and are not folded or crumpled. Add 2,0 ml of the 90 + 10 parts by volume ACN + DMSO extraction solution to each vial. Seal the vials with PTFE-lined caps and extract the samples on a shaker for 15 min. Transfer the extractant solutions to separate HPLC autosampler vials using separate 0,2 µm PTFE syringe filters to filter the solutions. Analyse reagent blanks (filter the solutions with syringe filters) to confirm that reagents are not contaminated.

8.3 Standards preparation

Prepare two stock standards from separate and independent sources for 2,4-TDI and 2,6-TDI. Stock standards for the isomers should be prepared separately if it is desired to quantitate both isomers. Prepare a minimum of five working range standards by diluting the stock standards with 90 + 10 parts by volume ACN + DMSO extraction solution. Working range standards for 2,4- and 2,6-TDI can be prepared in the same solution after it is confirmed that one isomer is not contaminated with the other isomer. Concentrations for the working range depend on the TDI levels expected in the samples. For example, the mass of 2,4-TDI equivalent to 20 nl/l for a 15 l sample is 2,1 µg/sample. Prepare the standards in 2,0 ml of extraction solution and express concentrations in terms of micrograms per sample. Standard concentrations shall bracket sample concentrations.

8.4 HPLC conditions

Column type (example): Polar embedded ODS-18, 150 × 4,6 mm, with optional similar phase guard column

Column temperature: 5 °C above ambient (or as appropriate)

Mobile phase: A = ACN and B = water buffered with 0,01 mol/l ammonium acetate adjusted to pH 6,2 with acetic acid

Gradient (typical): 25 % A + 75 % B for 0 min to 4 min
25 % A + 75 % B to 50 % A / 50 % B in 8 min
Hold at 50 % A + 50 % B for 3 min

Flow rate: 2,0 ml/min

Injection volume: 10 µl to 25 µl
Detector: UV at 254 nm
Fluorescence at 240 nm excitation, 370 nm emission

NOTE It is not essential that both detectors be used for this International Standard, but it is recommended that both detectors be employed whenever possible and that they be connected in series. Detector responses should be collected simultaneously by the data system so that they can be compared and then used to support quantitation and peak identification. The fluorescence detector is generally more sensitive than the UV detector. Typically, the fluorescence detector is used to quantitate samples containing 0,02 to 1 µg of TDI and the UV detector is used for samples containing more than 1 µg of TDI. A typical chromatogram with fluorescence detection of a sample containing approximately 1 µg per sample each TDI isomer is shown in Figure 2.

9 Analysis

9.1 Calibration

Calibrate both detectors for each series of samples by analysing at least five standards prepared from one of two separate and independent sources of TDI. Use standards prepared from the other source to verify the calibration curve. Results from the analysis of these standards should agree to within $\pm 10\%$ of their theoretical concentration. The concentrations of the standards should be within the linear range of the detectors. The concentration of the standards should not produce a detector signal that exceeds the capacity of the detector. A calibration verification standard should be analysed approximately every 10 air samples to verify calibration.

Although not specified in this method, the use of an internal standard is likely to improve the performance of the method. The internal standard can identify and/or correct such things as variability in injection volume and retention time drift.

9.1.1 Calibration curve

Prepare separate calibration curves for each TDI isomer and for both detectors by plotting the peak area or peak height of standards against their mass expressed in micrograms per sample.

10 Quality control

Prepare an appropriate number of analyst-spiked air sampling filters by spiking them with TDI standard solutions at levels expected to be present in the samples or at levels that correspond to the TDI exposure limit. Do not spike volumes greater than 20 µl. Analyse the analyst-spiked filters in the same manner as the air samples and include them for analysis along with the series of air samples. Analytical results for the analyst-spiked samples should be within $\pm 10\%$ of their actual levels.

Many laboratories have a formal quality control program in which internal analytical error is estimated. The estimate is usually developed from control charts based on the analysis of a series of blind quality control samples over a period of time. Sometimes analytical error is statistically combined with estimated sampling error and the resultant statistic enables the hygienist to make informed decisions regarding sample results and actual workplace exposures. Each laboratory shall develop its own quality control program and cannot use results from another laboratory.

11 Sample quantification

11.1 Determination of TDI mass per sample

Confirm that detector responses for air samples are within the range of detector responses for standards. High samples can be diluted with extraction solvent and then reanalyzed.

The mass, m_{sam} , in micrograms, per sample of 2,4- and 2,6-TDI shall be determined separately by comparing detector response for each isomer that is present in the sample to the appropriate calibration curve. Use the following equation:

$$m_{\text{sam}} = \frac{m_{\text{sam curve}} f_{\text{d}}}{\eta}$$

where

$m_{\text{sam curve}}$ is the mass, in micrograms, of TDI per sample from the calibration curve;

f_{d} is the sample dilution (if any) required to bring the sample result into the calibration range;

η is the extraction efficiency expressed as its decimal equivalent (each laboratory shall determine extraction efficiency internally).

11.2 Determination of TDI mass concentration in air

The mass concentrations, γ , in micrograms per cubic metre, in air for each TDI isomer are calculated using the following equation:

$$\gamma = \frac{m_{\text{sam}}}{V}$$

where

m_{sam} is the mass, in micrograms, of TDI per sample;

V is the air volume, in cubic metres, sampled.

11.3 Determination of TDI volume fraction in air

The air volume fractions, ϕ , in nanolitres per litre, for each TDI isomer are calculated using the following equation:

$$\phi = \frac{\gamma \times 24,45}{174,2}$$

where

γ is the mass concentration, in micrograms per cubic metre, of TDI by mass in air;

24,45 is the molar volume of an ideal gas at 25 °C and 760 mmHg;

174,2 is the molecular mass of TDI.

12 Interferences

It may be advisable to extract collected samples in the field by following the instructions in 8.2, if TDI aerosols are present.

Any chemical that reacts with 1-2PP or competes with it in the derivatization reaction with TDI is a potential sampling interference. Potential interferences include anhydrides, amines, alcohols, and carboxylic acids.

Any chemical having the same HPLC retention time as the TDI ureas and that provides both UV and fluorescence detector responses is a potential analytical interference. Analytical interferences can sometimes be resolved by altering HPLC conditions. If the ratio of the UV detector response to the fluorescence detector response is significantly different for standards and samples, then the possibility of analytical interferences shall be considered.

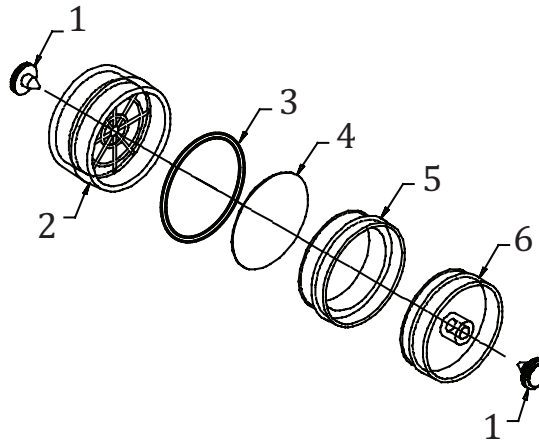

Key

- 1 End plug
- 2 Bottom
- 3 Spacer ring
- 4 Coated filter
- 5 Ring
- 6 Top

Figure 1 — Air sampling cassette

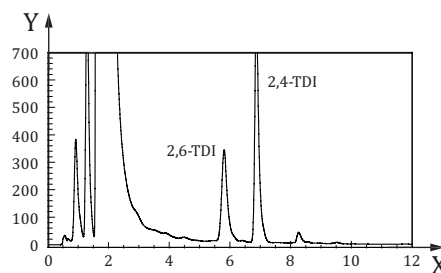

Figure 2 — A typical chromatogram for TDI

13 Determination of performance characteristics

13.1 Introduction

The uncertainty of the measurement of TDI in workplace air can be calculated and expressed as expanded uncertainty according to definitions of uncertainty presented in ISO/IEC Guide 98-3:2008,^[4] or in EN 482.^[6] An uncertainty assessment shall be performed according to one of these definitions of uncertainty. In both cases, an uncertainty assessment consists of the determination of various contributions to uncertainty

that is evaluated by means of laboratory and simulated field tests, or from existing information. The values obtained from the uncertainty of measurement calculations can then be compared with pre-set criteria, for example those in EN 482,^[6] or defined in national or international legislation.

This Clause, on the determination of performance characteristics, is taken from ISO 17735^[2] and ISO 17736^[3] with relatively few changes. Although the majority of factors that give rise to uncertainty in the methods described in ISO 17735^[2] and ISO 17736^[3] are the same as for this method, differences in the methods do result in some disparity in the contributing factors.

Relevant uncertainty contributions and criteria are listed in Table 1.

13.2 Relevant uncertainty contributions and criteria

Table 1

Uncertainty contribution	Symbol	Abbreviated term	Clause	Criterion
Test sample volume	V_{sam}	—	13.3.2	
Sample flow — calibration	q_{cal}	—		Relative uncertainty <2 %
Sample flow — variation	Δq	—		< 5 %
Sampling time	t	—		Relative uncertainty <3 %
Knowledge of temperature during sampling	T	—		Relative uncertainty <4 %
Knowledge of pressure during sampling	p	—		Relative uncertainty <2 %
Analyte mass	m_{sam}	—	13.3.3	
Analyte stability during storage	—	AS		No significant difference between results of analysis of samples before and after storage
Reaction/extraction efficiency	—	RE		>90 % at the limit value with a relative uncertainty of <3 %
Mass of isocyanate in calibration standards	m_{CS}	—		Relative uncertainty <2 %
Calibration lack-of-fit	—	lof		Relative residuals over the calibration range <3 %; at the limit value <2 %
Response drift between calibrations	—	RD		<3 %
Analytical precision (response)	—	r		<1 %
Selectivity	—	sel		Resolution factor >1
Blank level	m_{bl}	—	13.3.4	<3 ng with a relative uncertainty of <5 %
Between-laboratory variations	—	bL	13.3.5	Relative uncertainty <7,5 %

13.3 Assessment of performance characteristics (ISO GUM approach)

13.3.1 Collection efficiency

For a complete description of the performance requirements and tests to be performed, see EN 13005.^[7]

13.3.2 Air sampling

13.3.2.1 Sampling volume

The sampled volume of air, V_{sam} , is calculated on the basis of measuring the sample flow rate before and after sampling as specified in ISO 16200-1:

$$V_{\text{sam}} = \frac{(q_{\text{start}} + q_{\text{end}})}{2} t \quad (1)$$

where

- q_{start} is the sample flow rate at the beginning of the sampling period (usually in millilitres per minute);
- q_{end} is the sample flow rate at the end of the sampling period;
- t is the sampling time, in minutes.

The uncertainty in the volume of air sampled is built up of contributions from:

- the measurements of the flow rates before and after sampling;
- the measurement of the sampling time;
- variations in the flow rate during the sampling period;

and may be expressed as

$$\frac{u^2(V_{\text{sam}})}{V_{\text{sam}}^2} = \frac{u^2(q_{\text{start}}) + u^2(q_{\text{end}})}{(q_{\text{start}} + q_{\text{end}})^2} + \frac{u_t^2}{t^2} + \frac{u_{\text{var},q}^2}{[(q_{\text{start}} + q_{\text{end}})/2]^2} \quad (2)$$

where the last term represents the uncertainty contribution due to flow rate variations during sampling.

13.3.2.2 Sampling time

The sampling time t can be measured to within $\pm 0,5$ min. For a sampling time between 15 min and 4 h, the relative uncertainty due to the measurement of t is < 3 %.

13.3.2.3 Variations in flow rate during sampling

The flow rate during sampling is unknown. The uncertainty due to variations in the flow rate during sampling can be estimated by assuming a uniform distribution as:

$$u_{\text{var},q}^2 = \frac{(q_{\text{start}} - q_{\text{end}})^2}{12} \quad (3)$$

13.3.2.4 Conversion of sample volume to standard temperature and pressure

For the conversion of concentrations to STP, knowledge of the actual mean temperature and pressure during sampling is required. Uncertainties in values of T and p used for conversion may be obtained from:

- actual measurements, taking into account the uncertainty in the calibration of temperature and pressure sensors used as

$$u^2 = u_{\text{cal}}^2 + \frac{s_{\text{meas}}^2}{n} \quad (4)$$

where

u_{cal} is the uncertainty due to calibration of the sensor;

s_{meas} is the standard deviation of the temperature and pressure measurements;

n is the number of temperature and pressure measurements.

knowledge of extremes of temperature and pressure during sampling, assuming these to be uniformly distributed.

For example, if the temperature extremes are known to be T_{min} and T_{max} , the uncertainty in T may be calculated from:

$$u_T^2 = u_{\text{cal}}^2 + \frac{(T_{\text{max}} - T_{\text{min}})^2}{12} \quad (5)$$

Generally, the first term is negligible compared to the second.

13.3.2.5 Combined uncertainty of sample volume

The above uncertainty contributions are combined to give the uncertainty in the sample volume converted to STP as:

$$\frac{u^2(V_{\text{sam,STP}})}{V_{\text{sam,STP}}^2} = \frac{u^2(V_{\text{sam}})}{V_{\text{sam}}^2} + \frac{u^2(T)}{\bar{T}^2} + \frac{u^2(p)}{\bar{p}^2} \quad (6)$$

13.3.3 Analysis

13.3.3.1 Sampled mass

The mass of isocyanate in the air samples may be expressed as:

$$m_{\text{sam}} = \frac{m_{\text{anal}}}{\eta_{\text{CE}} v_{\text{SV}} s_{\text{AS}} \eta_{\text{RE}} f_{\text{RF}}} \quad (7)$$

where

η_{CE} is the collection efficiency;

v_{SV} is the sampler variability;

s_{AS} is the analyte stability in the sample;

η_{RE} is the reaction/extraction efficiency;

f_{RF} is the response factor;

m_{anal} is the uncorrected analytical mass of isocyanate in the analytical sample.

13.3.3.2 Analyte stability

The analyte stability shall be experimentally established for storage under conditions (time, temperature, environment) typical to the individual laboratory. Tests shall be performed at an isocyanate level corresponding to a concentration equivalent to the limit value.

At times $t = 0$ and $t = t$, n samples each shall be analysed under repeatability conditions ($n \geq 6$). For both times, the samples shall be randomly picked from a batch of representative samples in order to minimize possible systematic concentration differences. As a test of (in)stability, a t -test is performed (95 % confidence, two sided). The uncertainty of the stability determination consists of contributions from:

- desorption (random part of desorption efficiency);
- calibration (random part of calibration);
- analytical precision;
- inhomogeneity of the sample batch.

As such, the contribution of the determination of AS is already incorporated in other contributions and does not need to be taken into account.

13.3.3.3 Reaction/Extraction efficiency

The reaction/extraction efficiency of TDI and its uncertainty are typically obtained from replicate measurements on certified reference materials (CRMs) of TDI or of its reaction product(s). The uncertainty due to incomplete reaction/extraction for the TDI level corresponding to the limit value is calculated from contributions of:

- the uncertainty in the concentration of the CRM;
- the standard deviation of the mean recovery;
- the bias between the mass of TDI in the CRM and the mean mass of TDI determined as:

$$\frac{u_{\eta_{\text{RE}}}^2}{\eta_{\text{RE}}^2} = \frac{u_{\text{CRM}}^2}{m_{\text{CRM}}^2} + \frac{s^2(m_{\text{DE}})}{m_{\text{DE}}^2} + \frac{(m_{\text{DE}} - m_{\text{CRM}})^2}{m_{\text{CRM}}^2} \quad (8)$$

where

- m_{CRM} is the certified mass of TDI in CRM;
- u_{CRM} is the uncertainty in the certified mass of TDI in CRM;
- m_{DE} is the mean mass of TDI determined;
- $s(m_{\text{DE}})$ is the standard deviation of the mean of the replicate measurement results.

The last term, representing the uncertainty due to a significant bias between certified and determined mass, may be ignored if:

- the bias is statistically insignificant at the 95 % level;
- a correction is applied for the bias.

If a CRM is not available, the material with the highest metrological quality available should be used.

13.3.3.4 Response factor

This method quantifies TDI using relatively pure analytical standards that are either prepared in-house using pure reagents or that are purchased commercially and then diluted prior to analysis. There is negligible variation between the response factors for standards and samples.

13.3.3.5 Uncorrected analytical mass of compound

The uncertainty in the uncorrected analytical mass of a compound is determined by:

- the uncertainty in the concentrations of the calibration standards used;
- the lack-of-fit of the calibration function;
- drift of detector response between calibrations;
- the precision of the analysis;
- the selectivity of the chromatographic system.

13.3.3.6 Calibration standards

The uncertainty of the concentration of TDI in the calibration standards used depends on the type of calibration standard used.

For calibration standards consisting of solutions in 90 + 10 parts by volume ACN + DMSO, the uncertainty is made up of contributions from:

- the purity of TDI; this is generally known from the manufacturer's specifications as a minimum purity w_p , e.g. $w_p = 99$ % mass fraction or $w_p \geq 99$ % mass fraction. In the first case, the relative uncertainty due to impurity is given by $(100 - w_p)$ % mass fraction; in the second case, the relative uncertainty can be estimated assuming a uniform distribution to be

$$u_{\text{pur}}^2 = \frac{(100 - w_p)^2}{12} \quad (9)$$

- the uncertainties in the weighings of compounds and solutions, i.e. the uncertainty of the balance used.

The latter contribution is generally expressed for differential weighings as

$$u_{\text{weigh}}^2 = 2u_{\text{bal}}^2 \quad (10)$$

where u_{bal} is the uncertainty of the balance used.

13.3.3.7 Lack-of-fit of calibration function

The uncertainty due to lack-of-fit of the calibration function can be calculated for the relevant concentration (corresponding to a mass of TDI sampled at the limit value) from residuals of a calibration function obtained by a least-squares linear regression weighted in the concentration of TDI in the calibration standard as

$$u_{\text{lof}}^2 = \frac{(m_{\text{regr}} - m_{\text{std}})^2}{m_{\text{std}}^2} = w_{\text{res}}^2 \quad (11)$$

where

m_{reg} is the mass of TDI calculated from the regression equation at the level of the calibration standard corresponding closest to the mass of TDI representing a sample at the limit value

m_{std} is the mass of TDI present in the corresponding calibration standard

w_{res} is the relative residual for the particular concentration level.

NOTE The lack-of-fit of the calibration function contributes to the uncertainty due to incomplete extraction or reaction, if the latter's efficiency is significantly different from 1. In that case, irrespective of whether or not a correction for incomplete reaction/extraction is applied, the uncertainty due to lack-of-fit of the calibration function does not need to be taken into account in the uncertainty assessment.

13.3.3.8 Drift in detector response

The uncertainty due to response drift can be estimated from data on the relative differences in responses between subsequent calibrations as

$$u_{\text{drift}}^2 = \frac{(r_n - r_{n-1})^2}{12[(r_n + r_{n-1})/2]^2} \quad (12)$$

where r_n is the detector response for a calibration standard corresponding closest to the mass of TDI representing a sample at the limit value.

13.3.3.9 Precision of the analysis

The uncertainty due to the (im)precision of the analysis is determined by analysis under repeatability conditions of calibration standards of the same composition; a minimum of 6 replicate analyses shall be performed. The uncertainty is then calculated as

$$u_r^2 = \frac{s_{\text{anal}}^2}{nr^2} \quad (13)$$

where

s_{anal} is the standard deviation of the replicate responses;

n is the number of replicate analyses;

r is the mean response.

In the uncertainty assessment this contribution is already incorporated in contributions from the determination of reaction/extraction efficiency and needs not be taken into account.

13.3.3.10 Analytical selectivity

The separation system used (liquid chromatographic column, gradient program) shall be optimized in order to minimize uncertainty due to (unnoticed) co-elution of potential interferents.

The resolution R of the liquid chromatographic system used – given by Formula (14) – shall be better than 1. In that case, the maximum uncertainty due to co-elution is 2,5 %. The typical uncertainty contribution is then $\pm 0,7$ %.

$$R = \frac{\Delta t_r}{0,85(b_B + b_I)} \quad (14)$$

where

Δt_r is the difference in retention time, in seconds, of the analyte peaks and interferent;

b is the peak width at half height, in seconds, of the peak, with subscript "B" referring to the analyte peaks and subscript "I" to the interferent.

13.3.3.11 Combined uncertainty in the analytical mass of TDI

The above contributions are combined to give the uncertainty of the analytical mass of TDI excluding the uncertainty due to imprecision as

$$\frac{u^2(m_{\text{anal}})}{m_{\text{anal}}^2} = \frac{u_{\text{std}}^2}{\text{std}^2} + u_{\text{lof}}^2 + u_{\text{drift}}^2 + u_{\text{sel}}^2 \quad (15)$$

13.3.3.12 Combined uncertainty in the sampled mass of TDI

The contributions given in 13.3.3.3 to 13.3.3.8, 13.3.3.10 and 13.3.3.11 are combined to give the uncertainty of the mass TDI in the air sample as

$$\frac{u^2(m_{\text{sam}})}{m_{\text{sam}}^2} = \frac{u^2(m_{\text{anal}})}{m_{\text{anal}}^2} + \frac{u_{\eta_{\text{RE}}}^2}{\eta_{\text{RE}}^2} + \frac{u_{f_{\text{RF}}}^2}{f_{\text{RF}}^2} \quad (16)$$

13.3.4 Mass of compound in sample blank

The mass of TDI in a sample blank is determined by analysis under repeatability conditions of a series of sample blanks; a minimum of six replicate analyses shall be performed. The uncertainty is then calculated using the slope of the calibration function extrapolated to the blank response level as

$$u^2(m_{\text{BL}}) = \frac{s_{\text{BL}}^2}{na_{\text{BL}}} \quad (17)$$

where

s_{BL} is the standard deviation of the replicate analytical results;

n is the number of replicate analyses;

a_{BL} is the slope of the calibration function at the blank response level.

In case the blank response is below three times the noise level of the detector at the retention time of TDI, then the blank level and its uncertainty shall be calculated from the detector noise level using the slope of the calibration function extrapolated to zero response assuming a uniform distribution as

$$m_{\text{BL}} = \frac{3r_0}{2a_0} \quad (18)$$

$$u^2(m_{\text{BL}}) = \frac{9r_0^2}{12} \quad (19)$$

where

r_0 is the noise level;

a_0 is the slope of calibration function at zero response.

13.3.5 Between-laboratory uncertainty contributions

The procedures described above are not restrictive but allow for possible variations in approaches between laboratories. The resulting additional uncertainty contributions can be quantified by performing interlaboratory comparisons involving:

- the complete measurement procedure inclusive of sampling;
- the analytical part of the measurement procedure.

Interlaboratory comparisons shall be organized in accordance with ISO 5725-2 using samples of sufficient homogeneity to ensure that the contribution to the between-laboratory uncertainty due to inhomogeneity is negligible. In practice, an uncertainty due to inhomogeneity of <2 % is usually sufficient.

13.3.6 Combined uncertainty

The combined uncertainty of the TDI level in the air sampled is obtained by combination of contributions given in Formulae (6), (16), and (19), adding the between-laboratory uncertainty (if considered appropriate) as

$$u_c^2(\gamma) = u^2(m_{\text{sam}}) + u^2(m_{\text{BL}}) + u^2(V_{\text{sam,STP}}) + u_{\text{bL}}^2 \quad (20)$$

where u_{bL} is the between-laboratory uncertainty contribution.

13.3.7 Expanded uncertainty

The expanded uncertainty in the TDI concentration in the air samples at the 95 % confidence level is obtained by multiplying $u_c(\gamma)$ with a coverage factor of 2.

13.3.8 Uncertainty from performance criteria

When combining the uncertainties specified for the performance characteristics (13.3) a worst-case situation results. The resulting combined relative uncertainty, calculated as described in 13.3.6 is ± 10 %. The expanded uncertainty is ± 20 %.

Annex A (informative)

Performance characteristics

A.1 Uncertainty estimates

Uncertainty contribution	Uncertainty (%)	Comments
Sample volume	4	For a 15 min air sample at a flow rate of 1 l/min
Sample flow – calibration	2	Calibration instrument specification
Sample flow – variation	3	Estimation
Sampling time	0,2	
Knowledge of temperature during sampling	1	Estimation
Knowledge of pressure during sampling	1	Estimation
Analyte mass	4	
Analyte instability during storage	negligible	Storage stability test in Reference [9]
Reaction/extraction efficiency	2	Reaction/extraction efficiency test in Reference [9]
Response factor	negligible	Calibration verification standards are analyzed periodically throughout each analysis sequence.
Mass of TDI in calibration standards (weighing + dilution)	1	Estimation
Calibration lack-of-fit	2	Calculated over calibrated range in Reference [9]
Response drift between calibrations	negligible	Instrumental drift is inherently small and corrected by intermixing samples and calibration verification standards in each analysis sequence.
Analytical precision	1	Reference [9]
Selectivity	3	Estimation: the recommended HPLC conditions provide good resolution and comparison of UV and fluorescence results supports peak identification.
Blank level	1	Estimation: blanks are analysed along with related samples in each analysis sequence.
Between-laboratory variations	8	In an interlaboratory evaluation of ASTM D5836 ^[8] (the basis for this International Standard) with 13 participating laboratories, the average recovery from spiked media for 2,4-TDI was (106 ± 5,6) % and (104 ± 5,7) % for 2,6-TDI. The precision within a laboratory measured as repeatability coefficient of variation was 6,2 % for 2,4-TDI and 5,7 % for 2,6-TDI.

A.2 Combined uncertainty

Based on Formula (20) and the values given in A.1, the combined uncertainty is estimated as 10 %.

A.3 Expanded uncertainty

By using a coverage factor of 2, the expanded uncertainty is 20 %.

Bibliography

- [1] ISO 1042, *Laboratory glassware — One-mark volumetric flasks*
- [2] ISO 17735, *Workplace atmospheres-Determination of total isocyanate groups in air using 1-(9-anthracenylmethyl)piperazine (MAP) reagent and liquid chromatography*
- [3] ISO 17736, *Workplace air quality-Determination of isocyanate in air using a double filter sampling device and analysed by liquid chromatography*
- [4] ISO/IEC Guide 98-3:2008, *Uncertainty of measurement — Part 3: Guide to the expression of uncertainty in measurement*
- [5] EN 1232, *Workplace atmospheres — Pumps for personal sampling of chemical agents — Requirements and test methods [Equivalent to ISO/NP 13137]*
- [6] EN 482:2006, *Workplace atmospheres – General Requirements for the performance of procedures for the measurement of chemical agents*
- [7] EN 13005, *ISO Guide to the expression of uncertainty in measurement*
- [8] ASTM D5836, *Standard test method for determination of 2,4-toluene diisocyanate (2,4-TDI) and 2,6-toluene diisocyanate (2,6-TDI) in workplace atmospheres (1-2 PP method)*
- [9] OSHA Method 42, *1,6-Hexamethylene diisocyanate (HDI), toluene-2,6-diisocyanate (2,6-TDI), toluene-2,4-diisocyanate (2,4-TDI)*. Available (viewed 2012-08-17) at: <http://www.osha.gov/dts/sltc/methods/organic/org042/org042.html>
- [10] Bayer Material Science Environmental Analytics Laboratory. BMSEAL Method 1.7.6. Determination of Airborne Isocyanates, Unpublished work, 1992. Revised, Pittsburgh, PA, 2009
- [11] Goldberg P.A., Walker R.F., Ellwood P.A., Hardy H.L. Determination of trace atmospheric isocyanate concentrations by reversed-phase high performance chromatography using 1-(2-pyridyl) piperazine reagent. *J. Chromatogr. A*. 1981, **212** pp. 93–104

British Standards Institution (BSI)

BSI is the national body responsible for preparing British Standards and other standards-related publications, information and services.

BSI is incorporated by Royal Charter. British Standards and other standardization products are published by BSI Standards Limited.

About us

We bring together business, industry, government, consumers, innovators and others to shape their combined experience and expertise into standards-based solutions.

The knowledge embodied in our standards has been carefully assembled in a dependable format and refined through our open consultation process. Organizations of all sizes and across all sectors choose standards to help them achieve their goals.

Information on standards

We can provide you with the knowledge that your organization needs to succeed. Find out more about British Standards by visiting our website at bsigroup.com/standards or contacting our Customer Services team or Knowledge Centre.

Buying standards

You can buy and download PDF versions of BSI publications, including British and adopted European and international standards, through our website at bsigroup.com/shop, where hard copies can also be purchased.

If you need international and foreign standards from other Standards Development Organizations, hard copies can be ordered from our Customer Services team.

Subscriptions

Our range of subscription services are designed to make using standards easier for you. For further information on our subscription products go to bsigroup.com/subscriptions.

With **British Standards Online (BSOL)** you'll have instant access to over 55,000 British and adopted European and international standards from your desktop. It's available 24/7 and is refreshed daily so you'll always be up to date.

You can keep in touch with standards developments and receive substantial discounts on the purchase price of standards, both in single copy and subscription format, by becoming a **BSI Subscribing Member**.

PLUS is an updating service exclusive to BSI Subscribing Members. You will automatically receive the latest hard copy of your standards when they're revised or replaced.

To find out more about becoming a BSI Subscribing Member and the benefits of membership, please visit bsigroup.com/shop.

With a **Multi-User Network Licence (MUNL)** you are able to host standards publications on your intranet. Licences can cover as few or as many users as you wish. With updates supplied as soon as they're available, you can be sure your documentation is current. For further information, email bsmusales@bsigroup.com.

BSI Group Headquarters

389 Chiswick High Road London W4 4AL UK

Revisions

Our British Standards and other publications are updated by amendment or revision.

We continually improve the quality of our products and services to benefit your business. If you find an inaccuracy or ambiguity within a British Standard or other BSI publication please inform the Knowledge Centre.

Copyright

All the data, software and documentation set out in all British Standards and other BSI publications are the property of and copyrighted by BSI, or some person or entity that owns copyright in the information used (such as the international standardization bodies) and has formally licensed such information to BSI for commercial publication and use. Except as permitted under the Copyright, Designs and Patents Act 1988 no extract may be reproduced, stored in a retrieval system or transmitted in any form or by any means – electronic, photocopying, recording or otherwise – without prior written permission from BSI. Details and advice can be obtained from the Copyright & Licensing Department.

Useful Contacts:

Customer Services

Tel: +44 845 086 9001

Email (orders): orders@bsigroup.com

Email (enquiries): cservices@bsigroup.com

Subscriptions

Tel: +44 845 086 9001

Email: subscriptions@bsigroup.com

Knowledge Centre

Tel: +44 20 8996 7004

Email: knowledgecentre@bsigroup.com

Copyright & Licensing

Tel: +44 20 8996 7070

Email: copyright@bsigroup.com



...making excellence a habit.™