



BSI Standards Publication

Implants for surgery — Wear of total knee-joint prostheses

Part 3: Loading and displacement parameters for wear-testing machines with displacement control and corresponding environmental conditions for test

National foreword

This British Standard is the UK implementation of ISO 14243-3:2014. It supersedes BS ISO 14243-3:2004 which is withdrawn.

The UK participation in its preparation was entrusted to Technical Committee CH/150/4, Surgical Implants - Bone and Joint Replacements.

A list of organizations represented on this committee can be obtained on request to its secretary.

This publication does not purport to include all the necessary provisions of a contract. Users are responsible for its correct application.

© The British Standards Institution 2014. Published by BSI Standards Limited 2014

ISBN 978 0 580 73554 7

ICS 11.040.40

Compliance with a British Standard cannot confer immunity from legal obligations.

This British Standard was published under the authority of the Standards Policy and Strategy Committee on 31 October 2014.

Amendments issued since publication

Date	Text affected
------	---------------

**Implants for surgery — Wear of total
knee-joint prostheses —**

**Part 3:
Loading and displacement
parameters for wear-testing
machines with displacement control
and corresponding environmental
conditions for test**

*Implants chirurgicaux — Usure des prothèses totales de l'articulation
du genou —*

*Partie 3: Paramètres de charge et de déplacement pour machines
d'essai d'usure avec contrôle de déplacement et conditions
environnementales correspondantes d'essai*





COPYRIGHT PROTECTED DOCUMENT

© ISO 2014

All rights reserved. Unless otherwise specified, no part of this publication may be reproduced or utilized otherwise in any form or by any means, electronic or mechanical, including photocopying, or posting on the internet or an intranet, without prior written permission. Permission can be requested from either ISO at the address below or ISO's member body in the country of the requester.

ISO copyright office
Case postale 56 • CH-1211 Geneva 20
Tel. + 41 22 749 01 11
Fax + 41 22 749 09 47
E-mail copyright@iso.org
Web www.iso.org

Published in Switzerland

Contents

	Page
Foreword	iv
1 Scope	1
2 Normative references	1
3 Terms and definitions	1
4 Principle	4
5 Specimens, lubricants, and sample size	5
5.1 Fluid test medium	5
5.2 Test specimen	5
5.3 Control specimen	5
5.4 Number of test specimens	5
6 Apparatus	6
7 Procedure	7
7.1 Initial Measurements	7
8 Test report	12
9 Disposal of test specimen	13
Annex A (informative) Details of load and displacement parameters for the test cycle described in Figures 2 to 5	14

Foreword

ISO (the International Organization for Standardization) is a worldwide federation of national standards bodies (ISO member bodies). The work of preparing International Standards is normally carried out through ISO technical committees. Each member body interested in a subject for which a technical committee has been established has the right to be represented on that committee. International organizations, governmental and non-governmental, in liaison with ISO, also take part in the work. ISO collaborates closely with the International Electrotechnical Commission (IEC) on all matters of electrotechnical standardization.

The procedures used to develop this document and those intended for its further maintenance are described in the ISO/IEC Directives, Part 1. In particular the different approval criteria needed for the different types of ISO documents should be noted. This document was drafted in accordance with the editorial rules of the ISO/IEC Directives, Part 2 (www.iso.org/directives).

Attention is drawn to the possibility that some of the elements of this document may be the subject of patent rights. ISO shall not be held responsible for identifying any or all such patent rights. Details of any patent rights identified during the development of the document will be in the Introduction and/or on the ISO list of patent declarations received (www.iso.org/patents).

Any trade name used in this document is information given for the convenience of users and does not constitute an endorsement.

For an explanation on the meaning of ISO specific terms and expressions related to conformity assessment, as well as information about ISO's adherence to the WTO principles in the Technical Barriers to Trade (TBT) see the following URL: Foreword – Supplementary information.

The committee responsible for this document is ISO/TC 150, *Implants for surgery*, Subcommittee SC 4, *Bone and joint replacement*.

This second edition cancels and replaces the first edition (ISO 14243-3:2004) which has been technically revised. It incorporates also the Technical corrigendum ISO 14243-3:2004/Cor 1: 2006.

ISO 14243 consists of the following parts, under the general title *Implants for surgery — Wear of total knee-joint prostheses*:

- *Part 1: Loading and displacement parameters for wear-testing machines with load control and corresponding environmental conditions for test*
- *Part 2: Methods of measurement*
- *Part 3: Loading and displacement parameters for wear-testing machines with displacement control and corresponding environmental conditions for test*

Implants for surgery — Wear of total knee-joint prostheses —

Part 3:

Loading and displacement parameters for wear-testing machines with displacement control and corresponding environmental conditions for test

1 Scope

This part of ISO 14243 describes a test method that specifies flexion/extension relative angular movement between articulating components, the pattern of the applied force, speed and duration of testing, sample configuration and test environment to be used for the wear testing of total knee-joint prostheses in wear-testing machines having axial load control, flexion/extension angular motion control, AP displacement control and tibial rotation control.

The kinematics of this part of ISO 14243 may not be applicable to knee designs with a high degree of constraint, which could result in damage to the articulating components in the early stages of the test that would not be representative of clinical service.

2 Normative references

The following documents, in whole or in part, are normatively referenced in this document and are indispensable for its application. For dated references, only the edition cited applies. For undated references, the latest edition of the referenced document (including any amendments) applies.

ISO 7207-1, *Implants for surgery — Components for partial and total knee joint prostheses — Part 1: Classification, definitions and designation of dimensions*

ISO 14243-2:2009, *Implants for surgery — Wear of total knee-joint prostheses — Part 2: Methods of measurement*

3 Terms and definitions

For the purposes of this document, the terms and definitions given in ISO 14243-1 and the following apply.

3.1

Anterior/Posterior (AP) displacement

offset between the femoral component and the tibial component, measured in a direction which is perpendicular to both the force and flexion/extension axes

Note 1 to entry: The AP displacement is considered to be zero when the total knee-joint prosthesis is in the *reference position* (3.7) and is considered to be positive when the tibial component is anterior to its position with the total knee-joint prosthesis in the reference position.

3.2

AP force

shear force applied by the tibial on the femoral component along a line of action which is perpendicular to both the tibial axis and the flexion/extension axis and which passes through the axial force axis.

Note 1 to entry: The AP force is considered to be positive when it acts in a posterior-to-anterior direction.

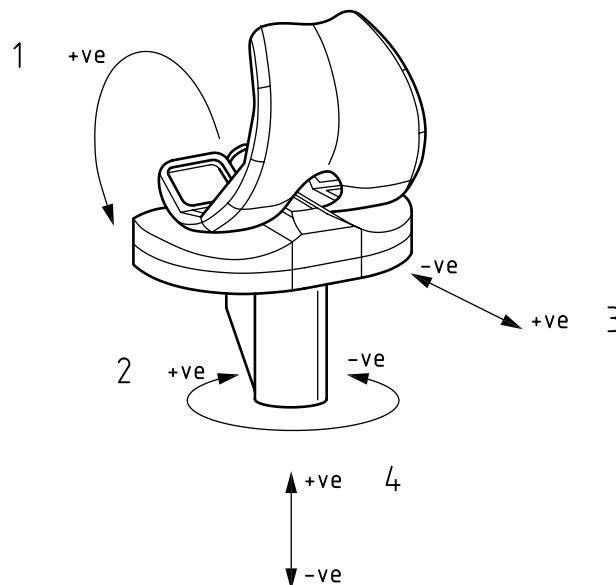

Key

- 1 flexion (of femoral component)
- 2 tibial rotation
- 3 AP displacement by the tibial component
- 4 axial force

Figure 1 — Sign convention for the forces and motions, shown for a left total knee replacement system

3.3 axial force

force applied by the tibial component of the knee-joint prosthesis on the femoral component in a direction parallel to the tibial axis

Note 1 to entry: It is considered to be positive when it acts in an inferior-to-superior direction. (See [Figures 1 and 2](#)).

3.4 axial force axis

line of action of the axial force taken to pass through a point on the tibial component of the knee-joint prosthesis which is offset by $0,07 w \pm 0,01 w$ in the medial direction from the tibial axis, where w is the overall width of the tibial component, measured in accordance with ISO 7207-1

Note 1 to entry: The value of $0,07 w$ offset equals 5 mm offset for a tibial component of average width, i.e. 74 mm. See [Figure 2](#).

3.5 flexion/extension axis

nominal axis of rotation of the femoral component relative to the tibial component

Note 1 to entry: For condylar and meniscal knees, the flexion/extension axis can be estimated by considering the condyles of the femoral component in contact with an imaginary plane perpendicular to the tibial axis when the femoral component is at 30° and 60° of flexion, and then visualizing four lines (contact normals) perpendicular to the imaginary plane running through the points where the two femoral condyles would contact the imaginary plane at each of these flexion angles. The flexion/extension axis is then the line that would intersect all four of the contact normals.

Note 2 to entry: The axis of rotation of the femoral component in the test will not exactly match the theoretical flexion/extension axis. The coincidence of the flexion/extension axis and the axis of rotation of the test machine should be as close as possible within reasonable laboratory practice.

3.6 load and displacement control wear-testing machine

wear-testing machine having axial load control, flexion/extension angular motion control, AP displacement control and tibial rotation control as its control parameters

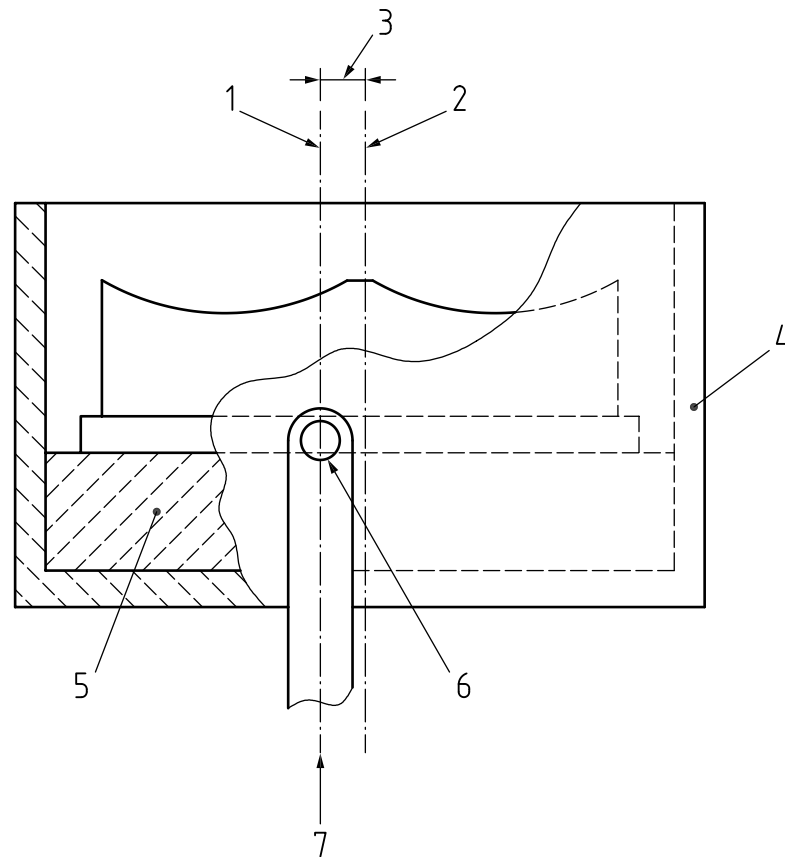

Key

- 1 axial force axis
- 2 tibial axis
- 3 0,07w offset
- 4 holder of tibial component
- 5 cement mounting for tibial component
- 6 axial force applied through free-turning pivot(s)
- 7 force

Figure 2 — Test specimen configuration

3.7 reference position

angular and linear alignment of the tibial component relative to the femoral component which gives static equilibrium of the tibial component when it is loaded against the femoral component by a positive axial force applied along the axial force axis, with the most distal points on the femoral bearing surface resting on the lowest points on the tibial bearing surface

Note 1 to entry: The reference position is equivalent to the position of 0° flexion (i.e. full extension) *in vivo*.

Note 2 to entry: For the purpose of determining the reference position, the effect of friction between the tibial and femoral components is ignored.

Note 3 to entry: The reference position can be determined by geometrical calculations based on the three-dimensional form of the tibial and femoral surfaces. For the purpose of these calculations, the form of the tibial and femoral surfaces can be taken either from design data or from coordinate measurements of an unworn total knee-joint prosthesis.

Note 4 to entry: In a moderately constrained or flat design of tibial component, and/or installation of the tibial component with a large posterior slope (see 7.4), the lowest points on the tibial bearing surface may span a large (flat) range of anterior-posterior positions, or be the most posterior edge of the tibial component (no dish effect). In such a situation, the above definition of reference position cannot apply. In such situations, the prosthesis manufacturer is consulted to decide what neutral position should be forced/set, and this should be noted in detail in the test report.

3.8 tibial axis

nominal longitudinal axis of the tibia, corresponding to the central axis of the medullary cavity of the proximal tibia

3.9 tibial rotation

rotation of the tibial component of the knee-joint prosthesis about an axis parallel to the tibial axis

Note 1 to entry: The rotation is considered to be zero when the total knee-joint prosthesis is in the *reference position* (3.7). For a right-sided total knee-joint prosthesis, the tibial rotation is positive when a view from a superior position onto the tibial component shows the tibial component rotated anti-clockwise from its position with the total knee-joint prosthesis in the *reference position* (3.7).

3.10 tibial rotation torque

torque applied by the tibial component on the femoral component of the total knee-joint prosthesis about an axis parallel to the tibial axis

Note 1 to entry: When seen from a position superior to the tibial component, the axial torque is positive when it acts clockwise on a left-sided total knee-joint prosthesis and positive when it acts anti-clockwise on a right-sided total knee-joint prosthesis.

3.11 passive soak control specimen

samples of the same polymer articulating components used in wear test will be immersed in the same fluid test medium at the same temperature for the same time as the wear test duration

3.12 loaded control specimen

sample(s) of the same polymer articulating components used in wear test will be immersed in the same fluid test medium at the same temperature for the same time with the same time varying axial force as the wear test, but without any articulating motions

3.13 tibial base plate

component of a modular tibial knee in contact with the tibia that supports the tibial polyethylene bearing component

4 Principle

The total knee-joint prosthesis is mounted in an apparatus that applies cyclic variations of flexion/extension angle, tibial rotation angle, AP displacement and axial force to the interface between tibial and femoral components, simulating normal human walking. The tibial component moves relative to the femoral component under the influence of the applied flexion/extension rotation, tibial rotation, AP displacement, and axial forces. The applied contact force/displacement actions are axial force, flexion/extension rotation, AP displacement and tibial rotation. All the applied force/displacement actions follow a specified cyclic variation, with a fixed relationship between the phases of the actions.

The contacting surfaces of the femoral and tibial components are immersed in a fluid test medium simulating human synovial fluid. A control specimen is subjected to the fluid medium and optionally to the same time-varying axial force to determine the creep of the test specimen and/or the amount of mass change due to fluid transfer. The test takes place in a controlled environment simulating physiological conditions.

5 Specimens, lubricants, and sample size

5.1 Fluid test medium

The fluid test medium shall be constituted by:

- Bovine serum diluted with deionized water to have a protein mass concentration of 20 g/l;
- Normally the fluid test medium is filtered through a 2 µm filter;
- To minimize microbial contamination, the fluid test medium should be stored frozen until required for test. An anti-microbial reagent (such as sodium azide) may be added. Such reagents can be potentially hazardous;
- Routine monitoring of the pH of the fluid test medium may be undertaken. If it is, the measured values should be included in the test report (see [Clause 8](#)).

5.2 Test specimen

Femoral and tibial components should be chosen so that their size combination and design detail represent the worst expected case for wear of the Total Knee Replacement system being tested. The tibial component should have the articulating surface attached by its normal immediate backing (for example bone cement or a machined replica of the inner surface of the tibial base plate) unless this is impractical due to physical features of the implant system. If the component forming the articulating surface is fixed to the tibial base plate by a rim/snap-fit system the machined replica shall provide the same fixation conditions.

If it is not practical to use the normal backing or cement fixation due to physical features of the implant system, the support system for the tibial component should represent normal design features and conditions of use but should allow removal of the component for measurement of wear (if required) without destruction.

The components shall be sterilized in the same way as for clinical use because this might affect the wear properties of the materials. Sterilization of all test and control components within a specific test group should be done simultaneously (in a single container) when possible, to minimize variation.

5.3 Control specimen

These components should be chosen so that their size combination and design are identical to the test specimen.

5.4 Number of test specimens

A minimum of three test specimens and a minimum of two control shall be tested to represent the wear of each type of prosthesis.

The control specimens may be used both for passive soak control or one as a passive soak control and the other for load control.

6 Apparatus

6.1 Testing machine, capable of applying the forces specified ([Figure 3](#)) in association with corresponding displacements, and operating at a frequency of $1 \text{ Hz} \pm 0,1 \text{ Hz}$.

6.2 Means of mounting and enclosing the test specimen, using a corrosion-resistant material, capable of holding femoral and tibial components using attachment methods comparable to the intended anatomical fixation.

An enclosure shall be provided that is capable of isolating the test specimen to prevent third-body contamination from the test machine and the atmosphere.

6.3 Means of aligning and positioning the femoral component of the test specimen in the reference position, so that the same position and orientation can be reproduced following the removal of the tibial component for measurement.

6.4 Means of aligning and positioning the tibial component of the test specimen in the inferior position, so that the same position and orientation can be reproduced after its removal for measurement.

6.5 Axial force control system, capable of generating an axial force following the cycle given in [Figure 3](#) and maintaining the magnitude of this force to a tolerance of $\pm 5 \%$ of the maximum value and $\pm 3 \%$ of the full cycle time for phasing.

The axial force is applied along the axial-force axis to the tibial component of the total knee-joint prosthesis through freely turning pivots which are offset from the tibial axis (see [Figure 3](#) and [Table 1](#)).

6.6 Flexion/extension rotation control system, capable of generating the flexion/extension motion as shown in [Table 2](#) and [Figure 4](#) and maintaining the magnitude of this motion to a tolerance of $\pm 5 \%$ of the maximum value and $\pm 3 \%$ of the full cycle time for phasing.

The flexion/extension motion is measured about the flexion/extension axis as a relative angular motion between the femoral and tibial components.

Provision shall be included for the adjustment of the reference position of the motion control system to coincide with the reference position so that when the applied flexion/extension motion reaches zero flexion angle, as shown in [Figure 4](#), the total knee-joint prosthesis is at the designed reference position.

For total knee-joint prostheses which include a positive extension stop, a device may be included to limit the extension moment which can be applied by over-extension.

6.7 AP displacement control system, capable of generating an AP motion following the cycle given in [Table 3](#) and [Figure 5](#) and maintaining the magnitude of this motion to a tolerance of $\pm 5 \%$ of the maximum value and $\pm 3 \%$ of the full cycle time for phasing.

The AP displacement is applied along the line of action which is perpendicular to both the tibial axis and the flexion/extension axis, and which passes through the axial-force axis.

6.8 Tibial-rotation control system, capable of generating a tibial rotation following the cycle given in [Table 4](#) and [Figure 6](#) and maintaining the magnitude of this rotation to a tolerance of $\pm 5 \%$ of the maximum value and $\pm 3 \%$ of the full cycle time for phasing.

The signs of the tibial rotation extremes are disregarded in determining the tolerance. The tibial rotation is applied about an axis parallel to the tibial axis and the positive direction is defined in [3.9](#).

6.9 AP force measurement system, capable of measuring the force along the line of action of the AP motion (see [6.7](#)).

This system is required only for component mounting, and is optional during testing.

6.10 Tibial-torque measurement system, capable of measuring the tibial rotational torque about the same axis as that of the applied tibial rotation (see [6.8](#)).

The recommended accuracy for the tibial-torque measuring system is at least $\pm 0,3$ Nm, and it should be possible to measure each specimen individually.

This system is required only for component mounting, and is optional during testing.

6.11 Lubrication system, capable of maintaining the contact surfaces immersed in fluid test medium.

NOTE The use of sealed enclosures inhibit evaporation.

6.12 Temperature control system, capable of maintaining the temperature of the fluid test medium at $37\text{ °C} \pm 2\text{ °C}$.

6.13 Control station(s), capable of applying the loading cycle shown in [Figure 3](#), without motions shown in [Figures 4](#), [5](#), and [6](#).

The control station shall incorporate the provisions of [6.2](#), [6.3](#), [6.4](#), [6.11](#) and [6.12](#).

Application of the load often causes only a small increase in fluid uptake, relative to the amount that is caused by lubrication and temperature control. It may not be necessary to use the applied load in the control samples if it has been demonstrated that this contribution is less than 5 % of the fluid uptake, for the materials being tested.

7 Procedure

7.1 Initial Measurements

Calibrate each test station using a load cell. This calibration must be performed while the load is being applied at all the other test stations, if any, in the test rig.

Make any initial measurements required to determine the subsequent amount of wear.

NOTE Methods of measurement are given in ISO 14243-2.

7.2 Following the initial measurements, clean the test specimen as specified in ISO 14243-2:2009, 4.5.2 to 4.5.5.

7.3 Mount the femoral component of the test specimen in the test machine, aligning it so that the AP force measurement system and the tibial torque measurement system show zero force and torque.

Depending on the design of the testing machine, this may require the mounting of the femoral component to be adjusted so that the flexion/extension axis coincides with the actual rotation axis of the flexion/extension motion applied by the test machine.

Table 1 — Variation of axial force with cycle time

Percentage of cycle time %	Axial force N
0	168
3	1 887
7	1 175
13	2 600
25	838
45	2 434
60	168
100	168

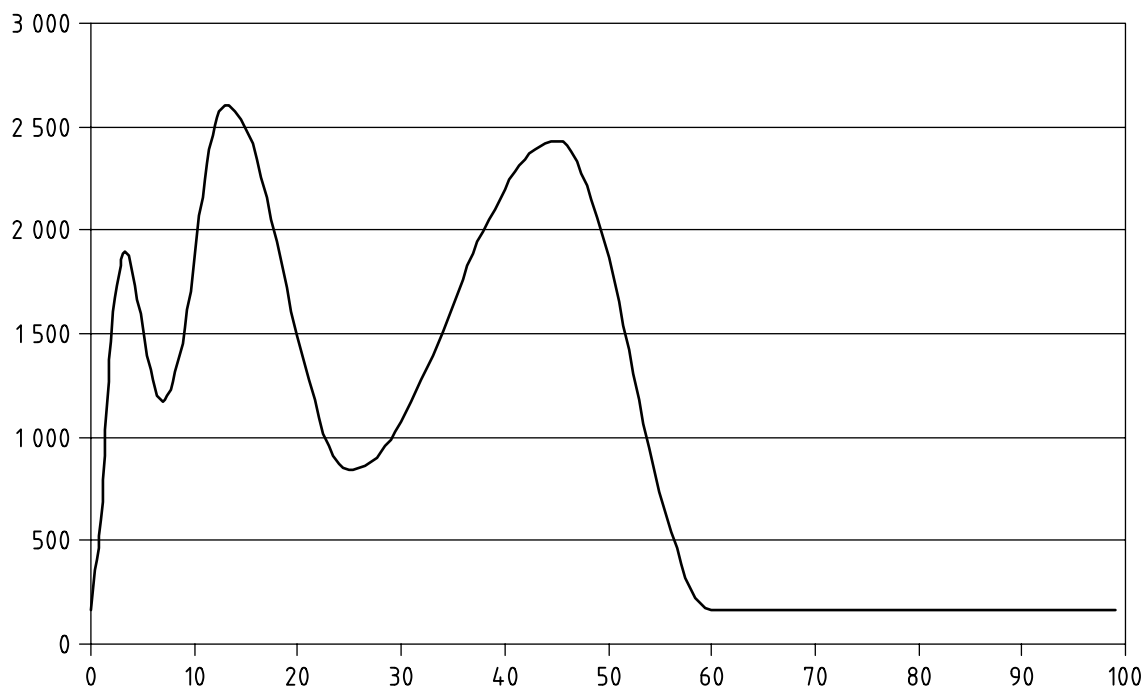

Key
 X percentage of time cycle, %
 Y axial force, N

Figure 3 — Control parameters — Variation of axial force with cycle time

Table 2 — Variation of flexion angle with cycle time

Percentage of time cycle %	Flexion angle degrees
0	0
16	16
41	5
73	58
100	0

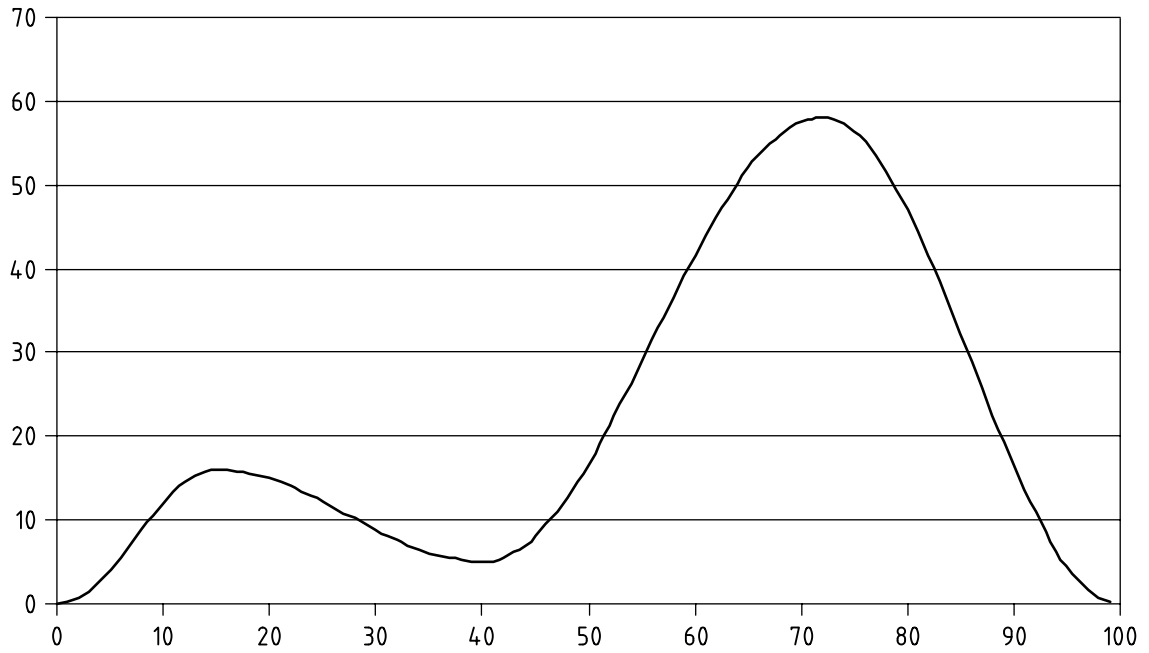

Key

X percentage of time cycle, %

Y flexion angle, degrees

Figure 4 — Control parameters — Variation of flexion angle with cycle time

Table 3 — Variation of AP motion with cycle time

Percentage of time cycle %	AP motion mm
0	0
17	+4,5
38	+0,3
56	+5,2
100	0

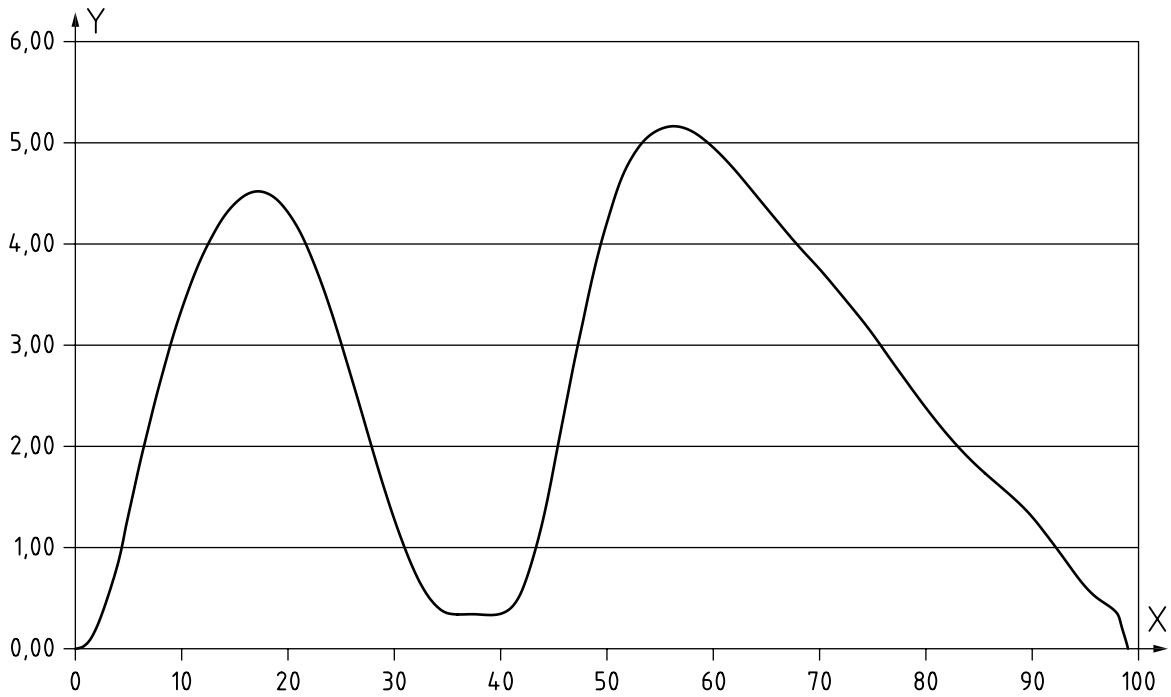

Key
 X percentage of time cycle, %
 Y AP motion, mm

Figure 5 — Control parameters — Variation of AP motion with cycle time

Table 4 — Variation of tibial rotation with cycle time

Percentage of time cycle %	Tibial rotation degrees
0	+1,6
2	+1,9
16	-1,2
40	+1,6
88	-5,7
100	+1,6

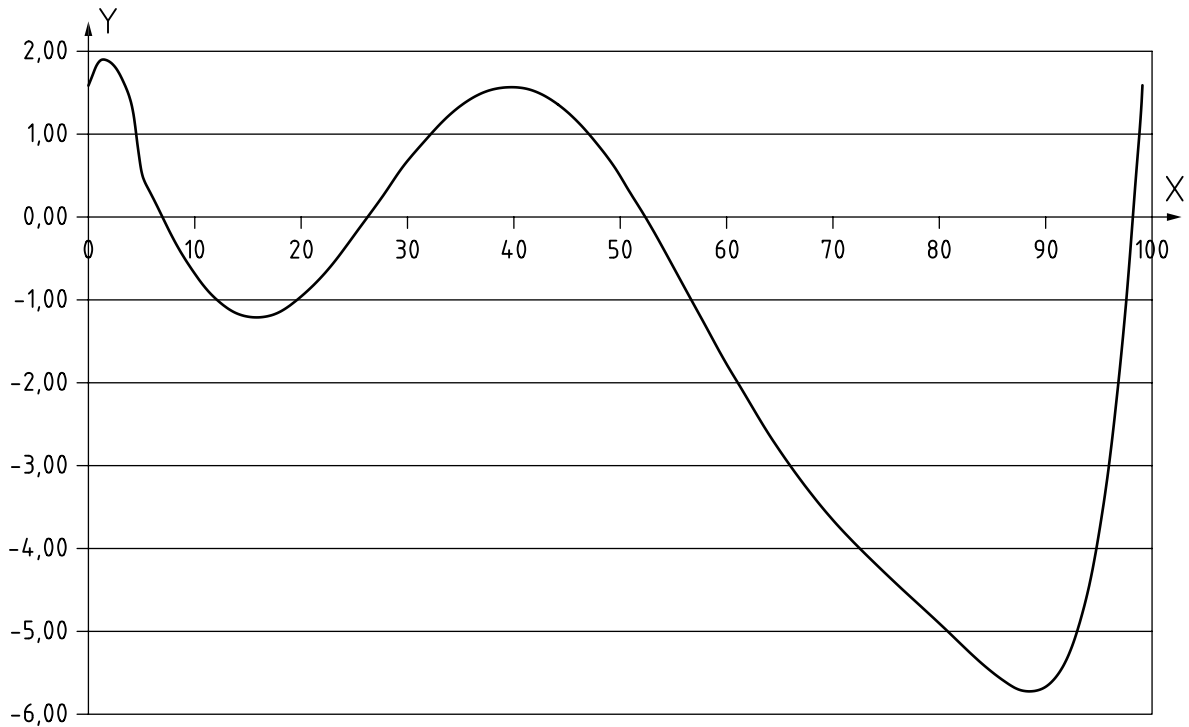

Key

X percentage of time cycle, %

Y tibial rotation, degrees

Figure 6 — Control parameters — Variation of tibial rotation with cycle time

7.4 Mount the tibial component of the test specimen in the test machine, aligning it so that the direction of the axial force applied by the machine is parallel to the tibial axis to within $\pm 1^\circ$. Incline the tibial component to the tibial axis at the angle recommended by the manufacturer for clinical use.

If the tibial component comprises an insert with a metal or other tibial base plate, the test should be conducted with the tibial base plate in place.

NOTE When the tibial component is mounted in a bed of cement, the alignment can be achieved by holding the tibial component with an adjustable temporary support with the cement in place and allowed to set.

7.5 Place the passive soak control specimens in a container and place the latter in a location with similar temperature as the test specimens. In the case of an active soak control specimen, repeat the steps in [7.1](#), [7.2](#), [7.3](#), and [7.4](#). For implants of a specific design with the same material, shape and dimensions, the control data from previous tests may be used.

7.6 Introduce the fluid test medium ([5.1](#)) to completely immerse the contact surfaces of the test specimen and the control specimen. Maintain the temperature of the fluid test medium at $37^\circ\text{C} \pm 2^\circ\text{C}$, taking the measurement at a location representative of the temperature of the bulk fluid.

7.7 Start the testing machine and adjust it so that the loads and displacements specified in [Figures 3 to 6](#) are applied to the test specimen and the loads specified in [Figure 3](#) are applied to the control specimen, with tolerances $\pm 3\%$ of the maximum force value and $\pm 5\%$ of the maximum angular and linear displacement values.

[Annex A](#) gives details of a typical set of test parameters equivalent to those described in [Figures 3 to 6](#). For knee designs with a high level of constraint, it may be possible to determine the appropriate

displacement values for the AP motion and tibial rotation using those displacement values that create the peak AP force values and rotational torque values given in ISO 14243-1:2009, Tables 3 and 4.

7.8 Operate the testing machine at a frequency of $1 \text{ Hz} \pm 0,1 \text{ Hz}$. The times of occurrence for the maxima and minima specified in [Figures 3 to 6](#) shall be controlled within $\pm 3 \%$ of the full cycle time.

7.9 Replace fluid lost by evaporation during the test at least daily, by adding deionized water. Replace the fluid test medium completely every 5×10^5 cycles.

7.10 The minimum cyclic stop test for measurements are 5×10^5 cycles, 1×10^6 cycles and at least every 1×10^6 cycles thereafter until one of the specified events occur (see [7.14](#)).

7.11 Remove the test specimen and control specimen and take wear measurements.

7.12 Following wear measurements, clean the test specimen and control specimen as appropriate for the material of construction and re-install in the test machine.

7.13 Repeat the steps given in [7.6](#) to [7.12](#), until the test is terminated (see [7.14](#)).

7.14 Continue the test until one of the following events occurs:

- a) completion of 5×10^6 load cycles. At the request of the party submitting the specimen for test, the test may be continued beyond this point;
- b) breaking up or delamination of the articulating surfaces that disrupt normal function of the implants;
- c) failure of the test machine to maintain the test conditions within the given tolerances (see [7.6](#), [7.7](#), [7.8](#) and [7.9](#)).

8 Test report

The test report shall include the following information:

- a) a reference to this part of ISO 14243 (i.e. ISO 14243-3);
- b) the identity of the test specimens as stated by the party submitting the specimen for test, including size, material, type and manufacture;
- c) description of the test machine, including number of stations, type of system used for generating motions and forces, range of motions and forces, type of system used for measuring motions and forces, arrangement for mounting specimen, arrangement for lubrication of articulating surfaces, arrangement for temperature control, and arrangement for the exclusion of contaminant particles;
- d) a statement of results, including:
 - the number of cycles applied;
 - the reason for terminating the test if less than 5×10^6 cycles were applied;
 - a description of all the surfaces of both components at which relative movement has occurred;
 - a description of the condition of the interfaces between subcomponents, if the components are of modular construction.

The test report shall be combined with the report of wear measurement compiled in accordance with ISO 14243-2, Clause 5.

9 Disposal of test specimen

No part of the test specimen or control test specimen shall be used for clinical purposes after testing.

Annex A (informative)

Details of load and displacement parameters for the test cycle described in [Figures 2 to 5](#)

Table A.1

Percentage of time cycle %	Flexion/extension angle degrees	Axial force N	AP motion mm	Tibial int./ext. rotation degrees
0	0	167,6	0	1,57
1	0,17	597,5	0,04	1,87
2	0,69	1 457,4	0,21	1,87
3	1,53	1 887,3	0,49	1,7
4	2,65	1 782,9	0,84	1,36
5	4	1 530,9	1,32	0,54
6	5,53	1 278,8	1,79	0,26
7	7,16	1 174,6	2,24	-0,01
8	8,84	1 270,1	2,65	-0,26
9	10,47	1 530,9	3,03	-0,49
10	12	1 887,3	3,36	-0,68
11	13,35	2 243,6	3,65	-0,85
12	14,47	2 504,5	3,90	-0,99
13	15,31	2 600	4,11	-1,09
14	15,83	2 570	4,28	-1,16
15	16	2 482	4,41	-1,19
16	15,96	2 342	4,49	-1,20
17	15,83	2 159,5	4,53	-1,18
18	15,61	1 947,1	4,51	-1,13
19	15,32	1 719,1	4,44	-1,05
20	14,95	1 491,1	4,32	-0,95
21	14,51	1 278,6	4,15	-0,83
22	14,01	1 096,2	3,93	-0,69
23	13,45	956,2	3,66	-0,54
24	12,84	868,2	3,36	-0,37
25	12,20	838,2	3,02	-0,20
26	11,53	848	2,67	-0,03
27	10,85	877,2	2,31	0,15

Table A.1 — (continued)

Percentage of time cycle %	Flexion/extension angle degrees	Axial force N	AP motion mm	Tibial int./ext. rotation degrees
28	10,16	925,1	1,94	0,33
29	9,47	990,5	1,60	0,51
30	8,80	1 071,8	1,28	0,67
31	8,16	1167	0,99	0,83
32	7,55	1 273,7	0,74	0,98
33	6,99	1 389,3	0,55	1,12
34	6,49	1 511,1	0,42	1,24
35	6,05	1 635,8	0,35	1,34
36	5,68	1 760,6	0,35	1,43
37	5,39	1 882,3	0,35	1,49
38	5,17	1 998	0,35	1,54
39	5,04	2 104,7	0,35	1,56
40	5	2 199,9	0,35	1,57
41	5,13	2 281,2	0,41	1,55
42	5,50	2 346,6	0,58	1,51
43	6,14	2 394,5	0,89	1,45
44	7,02	2 423,7	1,29	1,36
45	8,13	2 433,5	1,81	1,26
46	9,47	2 408,8	2,34	1,14
47	11,02	2 335,6	2,87	1,00
48	12,76	2 217,1	3,37	0,84
49	14,69	2 058,7	3,83	0,66
50	16,78	1 867	4,22	0,48
51	19,01	1 650,7	4,54	0,28
52	21,36	1419	4,80	0,07
53	23,80	1 182,2	4,97	-0,15
54	26,33	950,5	5,08	-0,38
55	28,90	734,1	5,14	-0,61
56	31,5	542,5	5,17	-0,85
57	34,10	384	5,16	-1,08
58	36,67	265,6	5,12	-1,32
59	39,19	192,4	5,05	-1,55
60	41,64	167,6	4,96	-1,78
61	44,00	167,6	4,86	-2,00
62	46,22	167,6	4,74	-2,22
63	48,31	167,6	4,62	-2,43

Table A.1 — (continued)

Percentage of time cycle %	Flexion/extension angle degrees	Axial force N	AP motion mm	Tibial int./ext. rotation degrees
64	50,24	167,6	4,49	-2,64
65	51,98	167,6	4,36	-2,83
66	53,53	167,6	4,24	-3,02
67	54,87	167,6	4,11	-3,19
68	55,98	167,6	3,99	-3,36
69	56,86	167,6	3,87	-3,52
70	57,49	167,6	3,75	-3,67
71	57,87	167,6	3,63	-3,81
72	58	167,6	3,51	-3,94
73	57,82	167,6	3,38	-4,07
74	57,27	167,6	3,25	-4,20
75	56,37	167,6	3,11	-4,32
76	55,13	167,6	2,96	-4,44
77	53,56	167,6	2,82	-4,56
78	51,67	167,6	2,67	-4,68
79	49,51	167,6	2,53	-4,80
80	47,08	167,6	2,38	-4,92
81	44,42	167,6	2,25	-5,04
82	41,58	167,6	2,12	-5,16
83	38,58	167,6	2,00	-5,29
84	35,45	167,6	1,89	-5,40
85	32,25	167,6	1,79	-5,51
86	29	167,6	1,70	-5,60
87	25,75	167,6	1,61	-5,68
88	22,55	167,6	1,51	-5,72
89	19,42	167,6	1,41	-5,72
90	16,42	167,6	1,30	-5,66
91	13,57	167,6	1,17	-5,53
92	10,92	167,6	1,03	-5,30
93	8,49	167,6	0,89	-4,94
94	6,33	167,6	0,74	-4,44
95	4,44	167,6	0,62	-3,75
96	2,87	167,6	0,51	-2,83
97	1,63	167,6	0,43	-1,64
98	0,73	167,6	0,34	-0,13
99	0,18	167,6	0	1,57

British Standards Institution (BSI)

BSI is the national body responsible for preparing British Standards and other standards-related publications, information and services.

BSI is incorporated by Royal Charter. British Standards and other standardization products are published by BSI Standards Limited.

About us

We bring together business, industry, government, consumers, innovators and others to shape their combined experience and expertise into standards-based solutions.

The knowledge embodied in our standards has been carefully assembled in a dependable format and refined through our open consultation process. Organizations of all sizes and across all sectors choose standards to help them achieve their goals.

Information on standards

We can provide you with the knowledge that your organization needs to succeed. Find out more about British Standards by visiting our website at bsigroup.com/standards or contacting our Customer Services team or Knowledge Centre.

Buying standards

You can buy and download PDF versions of BSI publications, including British and adopted European and international standards, through our website at bsigroup.com/shop, where hard copies can also be purchased.

If you need international and foreign standards from other Standards Development Organizations, hard copies can be ordered from our Customer Services team.

Subscriptions

Our range of subscription services are designed to make using standards easier for you. For further information on our subscription products go to bsigroup.com/subscriptions.

With **British Standards Online (BSOL)** you'll have instant access to over 55,000 British and adopted European and international standards from your desktop. It's available 24/7 and is refreshed daily so you'll always be up to date.

You can keep in touch with standards developments and receive substantial discounts on the purchase price of standards, both in single copy and subscription format, by becoming a **BSI Subscribing Member**.

PLUS is an updating service exclusive to BSI Subscribing Members. You will automatically receive the latest hard copy of your standards when they're revised or replaced.

To find out more about becoming a BSI Subscribing Member and the benefits of membership, please visit bsigroup.com/shop.

With a **Multi-User Network Licence (MUNL)** you are able to host standards publications on your intranet. Licences can cover as few or as many users as you wish. With updates supplied as soon as they're available, you can be sure your documentation is current. For further information, email bsmusales@bsigroup.com.

BSI Group Headquarters

389 Chiswick High Road London W4 4AL UK

Revisions

Our British Standards and other publications are updated by amendment or revision.

We continually improve the quality of our products and services to benefit your business. If you find an inaccuracy or ambiguity within a British Standard or other BSI publication please inform the Knowledge Centre.

Copyright

All the data, software and documentation set out in all British Standards and other BSI publications are the property of and copyrighted by BSI, or some person or entity that owns copyright in the information used (such as the international standardization bodies) and has formally licensed such information to BSI for commercial publication and use. Except as permitted under the Copyright, Designs and Patents Act 1988 no extract may be reproduced, stored in a retrieval system or transmitted in any form or by any means – electronic, photocopying, recording or otherwise – without prior written permission from BSI. Details and advice can be obtained from the Copyright & Licensing Department.

Useful Contacts:

Customer Services

Tel: +44 845 086 9001

Email (orders): orders@bsigroup.com

Email (enquiries): cservices@bsigroup.com

Subscriptions

Tel: +44 845 086 9001

Email: subscriptions@bsigroup.com

Knowledge Centre

Tel: +44 20 8996 7004

Email: knowledgecentre@bsigroup.com

Copyright & Licensing

Tel: +44 20 8996 7070

Email: copyright@bsigroup.com



...making excellence a habit.™