

BS ISO 14188:2012



BSI Standards Publication

Metallic and other inorganic coatings — Test methods for measuring thermal cycle resistance and thermal shock resistance for thermal barrier coatings

bsi.

...making excellence a habit.™

National foreword

This British Standard is the UK implementation of ISO 14188:2012.

The UK participation in its preparation was entrusted to Technical Committee STI/40, Thermally sprayed inorganic finishes.

A list of organizations represented on this committee can be obtained on request to its secretary.

This publication does not purport to include all the necessary provisions of a contract. Users are responsible for its correct application.

© The British Standards Institution 2012.
Published by BSI Standards Limited 2012

ISBN 978 0 580 69103 4

ICS 25.220.20

Compliance with a British Standard cannot confer immunity from legal obligations.

This British Standard was published under the authority of the Standards Policy and Strategy Committee on 31 October 2012.

Amendments issued since publication

Date	Text affected
------	---------------

**Metallic and other inorganic coatings —
Test methods for measuring thermal
cycle resistance and thermal shock
resistance for thermal barrier coatings**

*Revêtements métalliques et autres revêtements inorganiques —
Méthodes d'essai pour mesurer la résistance au cyclage thermique et la
résistance au choc thermique des revêtements barrières thermiques*





COPYRIGHT PROTECTED DOCUMENT

© ISO 2012

All rights reserved. Unless otherwise specified, no part of this publication may be reproduced or utilized in any form or by any means, electronic or mechanical, including photocopying and microfilm, without permission in writing from either ISO at the address below or ISO's member body in the country of the requester.

ISO copyright office
Case postale 56 • CH-1211 Geneva 20
Tel. + 41 22 749 01 11
Fax + 41 22 749 09 47
E-mail copyright@iso.org
Web www.iso.org

Published in Switzerland

Contents		Page
Foreword		iv
Introduction		v
1	Scope	1
2	Normative references	1
3	Terms and definitions	1
4	Principle	3
5	Test methods	3
5.1	General	3
5.2	Thermal cycle resistance method	3
5.3	Thermal shock resistance method	10
6	Test reports	13
6.1	General	13
6.2	Test report of thermal cycle resistance method	14
6.3	Test report of thermal shock resistance method	14
Bibliography		15

Foreword

ISO (the International Organization for Standardization) is a worldwide federation of national standards bodies (ISO member bodies). The work of preparing International Standards is normally carried out through ISO technical committees. Each member body interested in a subject for which a technical committee has been established has the right to be represented on that committee. International organizations, governmental and non-governmental, in liaison with ISO, also take part in the work. ISO collaborates closely with the International Electrotechnical Commission (IEC) on all matters of electrotechnical standardization.

International Standards are drafted in accordance with the rules given in the ISO/IEC Directives, Part 2.

The main task of technical committees is to prepare International Standards. Draft International Standards adopted by the technical committees are circulated to the member bodies for voting. Publication as an International Standard requires approval by at least 75 % of the member bodies casting a vote.

Attention is drawn to the possibility that some of the elements of this document may be the subject of patent rights. ISO shall not be held responsible for identifying any or all such patent rights.

ISO 14188 was prepared by Technical Committee ISO/TC 107, *Metallic and other inorganic coatings*.

Introduction

Thermal barrier coatings are highly advanced material systems, generally applied to surfaces of hot-section parts made of nickel or cobalt based superalloys, such as blades, vanes and combustors in gas turbines and aero-engines, operated at elevated temperatures.

The purpose of these coatings is to insulate metallic components for an extended period at elevated temperatures by employing thermally insulating materials which can sustain an appreciable temperature difference between load bearing alloys and coating surfaces. By shielding these parts, these coatings permit the use of high operating temperatures by restricting exposure of structural parts to these temperatures, thereby extending their lives.

This International Standard specifies test methods, applicable to these thermal barrier coatings, for measuring thermal cycle resistance and thermal shock resistance using appropriate heating and cooling procedures.

Metallic and other inorganic coatings — Test methods for measuring thermal cycle resistance and thermal shock resistance for thermal barrier coatings

1 Scope

This International Standard specifies test methods applicable to thermal barrier coatings for measuring thermal cycle resistance by using steady cyclical heating and cooling procedures, and for measuring thermal shock resistance using a heating and quenching technique.

These measurements are used for the evaluation of durability of thermal barrier coatings to thermal strain.

This International Standard is applicable for screening thermal barrier coating systems including materials and processing, and not for controlling the thermal spraying processes.

2 Normative references

The following referenced documents are indispensable for the application of this document. For dated references, only the edition cited applies. For undated references, the latest edition of the referenced document (including any amendments) applies.

ISO 14232, *Thermal spraying — Powders — Composition and technical supply conditions*

ISO 14916, *Thermal spraying — Determination of tensile adhesive strength*

3 Terms and definitions

For the purposes of this document, the following terms and definitions apply.

3.1

thermal barrier coating

TBC

two-layer coating consisting of a metallic bond coat and an oxide top coat, in order to reduce heat transfer from outside the top coat through the coating to the base material

NOTE When a TBC is exposed to operating at a high temperature, thermally grown oxide (TGO) develops on the top of the bond coat. The substrate is a typically heat-resistant high nickel based alloy class, UNS N 06002 type of material. The coatings, illustrated in Figure 1, are applied by using physical or chemical vapour deposition or by thermal spray processes, such as plasma spray and high velocity oxy-fuel (HVOF) spray conforming to ISO 14232.

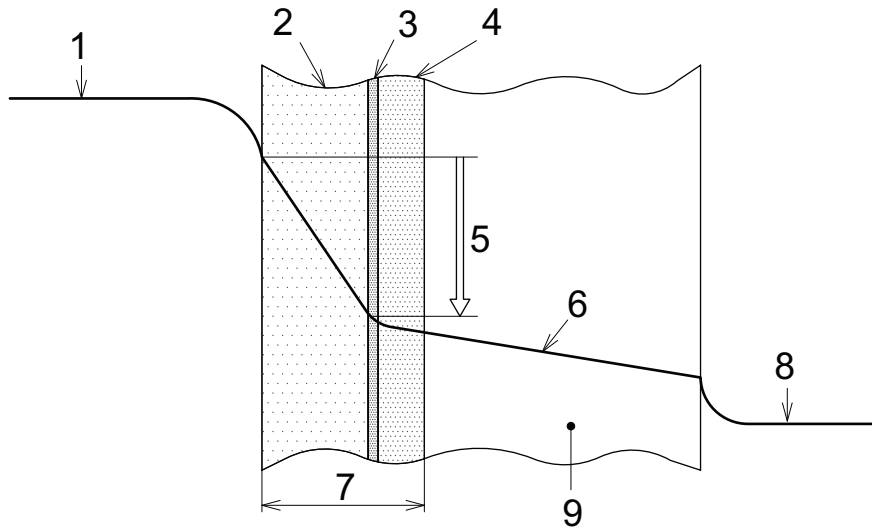

Key

- 1 combustion gas temperature
- 2 top coat
- 3 TGO
- 4 bond coat
- 5 thermal barrier effect
- 6 temperature
- 7 TBC
- 8 cooling air temperature
- 9 substrate

Figure 1 — Diagrammatic view of the section and effects of TBC

3.2
thermally grown oxide
TGO

oxide grown between top and bond coat when the coating system is heated

3.3
ratio of spalling areas
proportion of the total spalling area relative to the effective area of the TBC

3.4
critical number of cycles to spalling
number of thermal cycles immediately prior to achieving 30 % in ratio of spalling area

NOTE In the assessment of spalling area, areas of delamination or cracking are excluded.

3.5
thermal shock temperature difference
difference in temperatures between heating and cooling water treatments of the test pieces in thermal shock tests

3.6
thermal shock resistance
thermal shock temperature difference that causes a reduction of tensile adhesive strength immediately prior to a decrease of 30 % relative to the tensile adhesive strength in the absence of thermal shock

4 Principle

The test methods include the thermal cycle resistance test by using steady cyclical heating and cooling procedures and consist of measuring ratio of spalling areas, and the thermal shock resistance test by measuring tensile adhesive strength following application of thermal shock. Thermal shock is applied by heating the test pieces in a furnace to the appropriate temperature and quenching in water. The coatings are applied by physical, chemical vapour deposition or by thermal spray processes such as plasma spray and high velocity oxy-fuel (HVOF) spray by using feedstock powders (ISO 14232).

5 Test methods

5.1 General

- a) All measurements related to physical quantities, dimensions and quantities and unit systems shall be carried out in accordance with appropriate International Standards (see Bibliography).
- b) When ordering testing in accordance with this International Standard, agreement between the contracting parties are needed in writing in contract or purchase order, concerning the following:
 - 1) handling and sectioning procedures, method of application of coatings, whether the coating surface is to be used as coated;
 - 2) for the thermal cycle test, selection of test pieces, position and size of piercing on test pieces, number of and any interruption of thermal cycles, and upper limit of high temperature, heating time, holding time at high temperature, cooling time and holding time at low temperature of a thermal cycle.

5.2 Thermal cycle resistance method

5.2.1 General

The test method covers a thermal cycle resistance test by using steady cyclical heating and cooling procedures and consists of measuring ratio of spalling areas. This method is useful in the selection of materials, coating processes and process conditions in the TBC system used in gas turbines operating at elevated temperatures.

5.2.2 Apparatus

The apparatus consists of a heating and cooling device and temperature control system, and is shown in Figure 2.

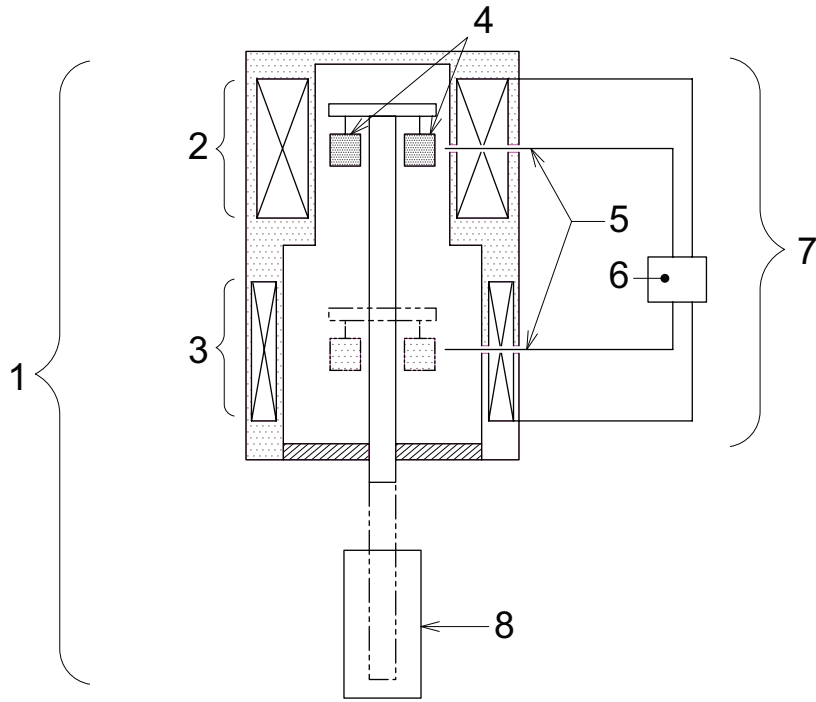

a) Vertical type

Key

- 1 heating and cooling device
- 2 high-temperature bath
- 3 low-temperature bath
- 4 test piece
- 5 thermocouple
- 6 temperature controller
- 7 temperature control system
- 8 test-piece-moving device

Figure 2 — Typical device for thermal cycle resistance method (continued)

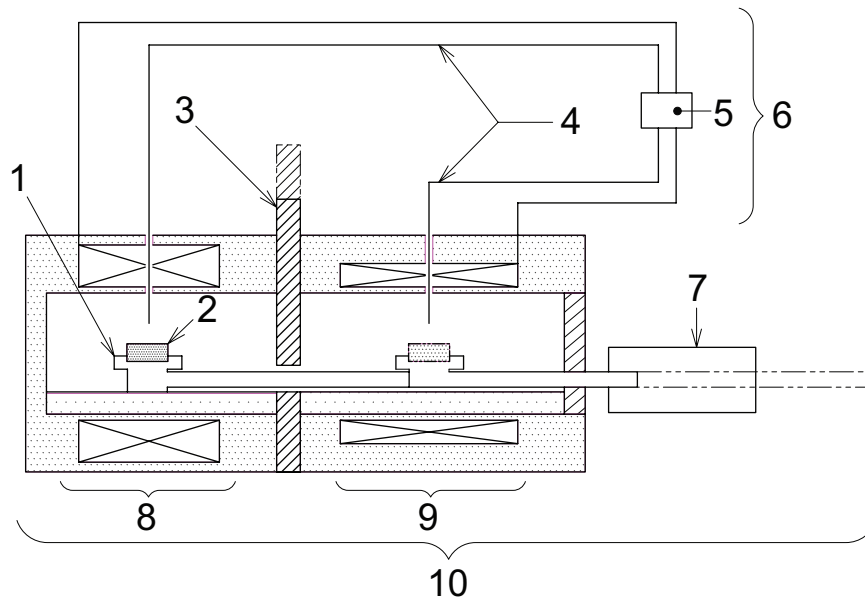

b) Horizontal type

Key

- 1 test piece support
- 2 test piece
- 3 shield plate (up/down possible)
- 4 thermocouple
- 5 temperature controller
- 6 temperature control system
- 7 test-piece-moving device
- 8 high-temperature bath
- 9 low-temperature bath
- 10 heating and cooling device

Figure 2 — Typical device for thermal cycle resistance method

5.2.2.1 Heating and cooling device

- a) The heating and cooling device consists of high- and low-temperature baths respectively. The atmosphere in both baths is air.
- b) The test piece is placed alternately in the two baths which are fixed; or alternatively, the test piece is fixed and the baths are alternated.
- c) The test pieces may be directly exposed to ambient air instead of using the low-temperature bath.
- d) The temperature control system consists of the temperature controller and thermocouples (see Figure 2). The temperature is regulated to ensure that the temperature of the test pieces is within the range given in Table 1.

Table 1 — Permissible temperature deviation from the target test temperature of test pieces

Test temperature °C	Permissible deviation °C
Room temperature to ≤ 600	±3
> 600 to ≤ 800	±4
> 800 to ≤ 1 000	±5
> 1 000	±7

5.2.3 Test pieces

5.2.3.1 Test pieces

The test pieces shall be of the flat plate type (Figure 3) or the disk type (Figure 4). To facilitate handling, the test pieces may be pierced.

Chamfering or rounding of the substrate edges shall appropriately be applied in order to avoid stress concentration at these locations.

5.2.3.2 Measurement of dimensions

Measure the dimensions of the parts to the nearest 0,1 mm using appropriate instruments [see 5.1.a)].

5.2.3.3 Measurement of mass of test pieces

Weigh the test pieces to the nearest 1 mg using appropriate instruments [see 5.1.a)].

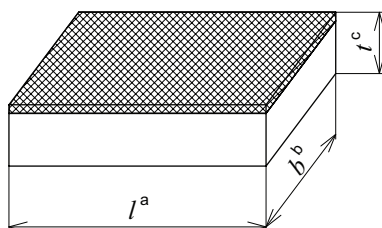

Key

l length

b width

t total thickness

^a 20 mm to 100 mm

^b 20 mm to 50 mm

^c 1,5 mm to 12,7 mm

The shaded area is covered with the TBC.

Figure 3 — Shape and dimensions of flat-plate-type test piece

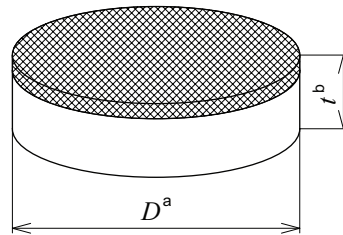

Key

D outside diameter

t total thickness

^a 20 mm to 40 mm

^b 1,5 mm to 5,0 mm

The shaded area is covered with the TBC.

Figure 4 — Shape and dimensions of disk-type test piece

5.2.4 Test procedures

5.2.4.1 Heating and cooling methods

Test pieces are held in the low-temperature bath before transferring them to the high-temperature bath and are held there for a specified duration. Once the test pieces have achieved stability, they are then relocated to the low-temperature bath and held there for a specified duration. A thermal cycle, shown in Figure 5, therefore, consists of a period of stability in the low-temperature bath and subsequently a period of stability in the high-temperature bath at the specified temperature.

The temperatures at the high and low temperature are calibrated by attaching thermocouples to dummy test pieces for adjustment to the specified temperature prior to the actual test runs.

The number of thermal cycles is referred to in 5.1 b) 2).

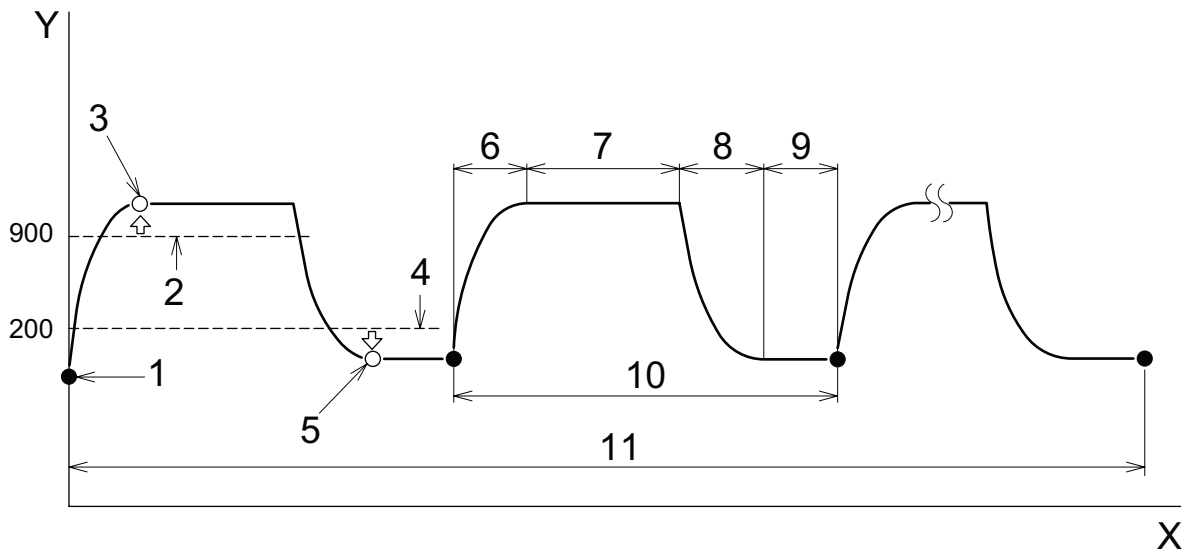

Key

- 1 start
- 2 lower limit
- 3 temperature at high temperature
- 4 upper limit
- 5 temperature at low temperature
- 6 heating time
- 7 holding time at high temperature
- 8 cooling time
- 9 holding time at low temperature
- 10 1 cycle
- 11 N cycles (N : 1, 2, 3, ...)
- X time
- Y temperature, T (°C)

Figure 5 — A typical thermal cycle

5.2.4.2 Heating and cooling conditions

- a) Table 1 shows the permissible temperature deviation from the target test temperature. For the high test temperature, the lower limit shall be 900 °C; and for the low test temperature, the upper limit shall be 200 °C. For the upper limit of the high-temperature range, see 5.1.b) 2).
- b) An example of a temperature pattern for a thermal cycle, shown in Figure 5, consists of 10 min for a temperature rise from 200 °C to 900 °C, 30 min for maintaining the test piece at the high temperature, 15 min for the temperature to drop from 900 °C to 200 °C, and 5 min for maintaining the test piece at the low temperature. Time conditions in a thermal cycle may be varied [see 5.1 b) 2)].
- c) Multiple test pieces may be treated simultaneously to enhance the efficiency of the test procedures.

5.2.4.3 Examination for spalling during thermal cycle resistance test

- a) The test may be interrupted after completion of an agreed number of cycles and the test piece is allowed to cool down to 200 °C and examined for any spalling. Once the number of cycles up to the stage when spalling occurs has been calculated or estimated, tests may be continued until close to the completion of the expected number of cycles.
- b) Inspect the test piece for cracks in the TBC or spalling visually with normal or corrected vision.

c) If cracks or spalling are detected, record them photographically.

5.2.4.4 Measurement of ratio of spalling areas

- a) Assess the spalling area in the TBC using, for example, image analysis from the record [see 5.2.4.3 c)]. For multiple spalling sites, the spalling area shall be the total of all spalling locations. Figure 6 illustrates typical spalling sites and total spalling area.
- b) For the occurrence of severe oxidation of the test pieces, weigh them and assess the mass loss (see 5.2.3.3).

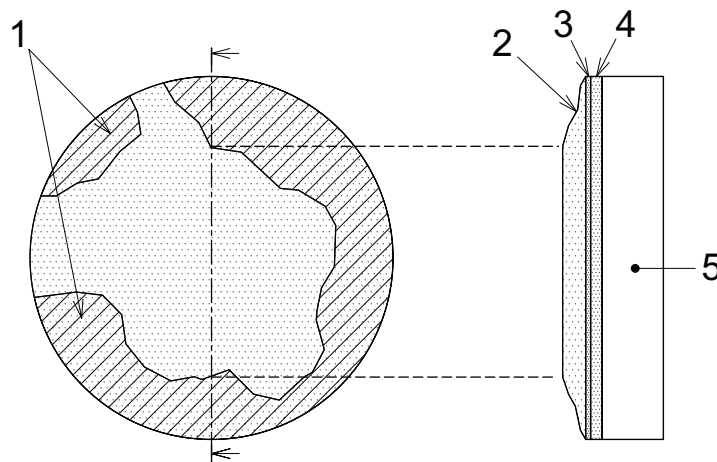

Key

- 1 spalling area
- 2 top coat
- 3 TGO
- 4 bond coat
- 5 substrate

The view of the test piece surface is shown on the right and the sectional view of the middle portion is shown on the left.

Figure 6 — Typical spalling sites and cross-sectional view of middle part

5.2.4.5 Determination of critical number of cycles to spalling

The critical number of cycles to spalling is the number of thermal cycles immediately prior to achieving an increase in the ratio of spalling area by 30 %.

Use three or more test pieces for the same test conditions to determine the critical number of cycles to spalling. The test is to be considered as completed when the ratio of spalling areas exceeds 30 % of the TBC or the number of thermal cycles reaches the number specified in 5.1 b) 2).

If the TBC has spalled more than 30 % in area during one thermal cycle, the critical number of cycles is to be considered as one.

The relationship between the number of thermal cycles and the ratio of spalling areas (see 3.3) is shown in Figure 7.

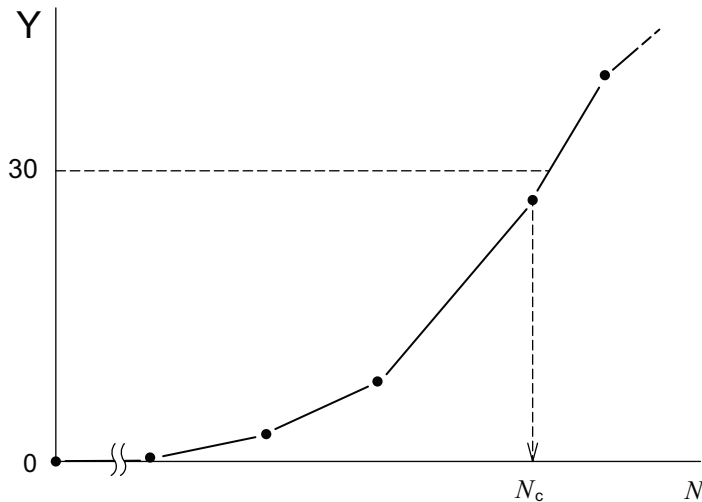

Key

- N_c critical number of cycles to spalling
- N number of thermal cycles (time)
- Y ratio of spalling area (%)

Figure 7 — An example of the relationship between the number of thermal cycles and ratio of spalling areas

5.2.4.6 Examination of the test piece after completion of the thermal cycle resistance test

- a) Examine the test pieces in accordance with 5.2.4.3.
- b) Examine the microstructure of the cross-section of the test pieces at an appropriate magnification and record it photographically.

5.3 Thermal shock resistance method

5.3.1 General

Thermal shock is used to evaluate the effectiveness of resistance to spalling of the TBC and to measure the tensile adhesive strength of test pieces under special environmental conditions, such as emergency shutdown in gas turbines, etc.

5.3.2 Apparatus

The apparatus consists of a heating device, temperature control system and a cooling water bath, and is shown in Figure 8.

5.3.2.1 Heating device and cooling water bath

- a) The heating device consists of the temperature control system (see 5.2.2.1 d)] with a furnace capable of heating in the temperature range shown in Table 1 and having a test chamber allowing a flow of ambient air.
A muffle electric resistance furnace may also be used.
- b) The cooling water bath consists of a water bath with a thermometer to measure the water temperature and a stirrer, and is of an adequate capacity to cool the entire test piece rapidly.

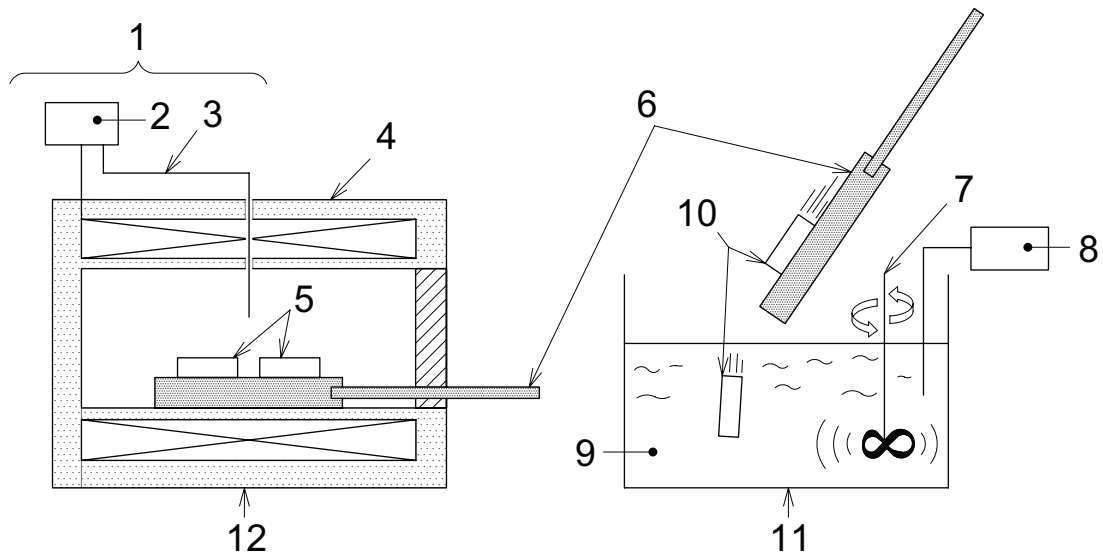

Key

- 1 temperature control system
- 2 temperature controller
- 3 thermocouple
- 4 heating furnace
- 5 test piece
- 6 test piece support
- 7 stirrer
- 8 thermometer
- 9 water
- 10 test piece
- 11 cooling water bath
- 12 heating device

Figure 8 — Typical device for thermal shock resistance test

5.3.3 Test pieces

- a) The test pieces shall be of the disk type (Figure 9). The substrates are to be coated with the TBC on both sides. If application of coating on both sides is not possible, only one side may be coated.

Chamfering or rounding of the substrate edges shall be applied appropriately in order to avoid stress concentration at these locations.

- b) For all other conditions, see 5.1.

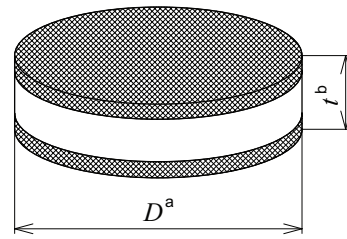

a) TBC covering both sides

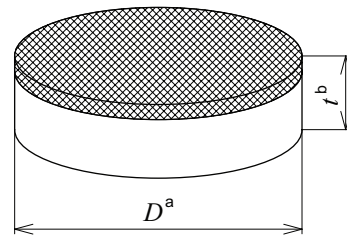

b) TBC covering only one side

Key

D outside diameter

t total thickness

^a 20 mm to 40 mm

^b 1,5 mm to 5,0 mm

Figure 9 — Shape and dimensions of disc-type test pieces

5.3.4 Test procedures

5.3.4.1 Thermal shock procedure

Place the test piece in the heating device operated at the specified temperature for 10 min and then place it immediately in the cooling water bath operated at $20\text{ °C} \pm 3\text{ °C}$ for rapid cooling until the test piece is fully cooled. The number of thermal shocks applied to the test piece is only one.

5.3.4.2 Examination for cracking and spalling following thermal shock process

Inspect the test piece for cracking or spalling in the TBC visually. If cracking or spalling is detected in the TBC, record this fact. Measurement of the tensile adhesive strength is not needed in this instance. Use three or more test pieces for the same test conditions.

5.3.4.3 Measurement of tensile adhesive strength

Following thermal shock tests, measure the tensile adhesive strength in accordance with ISO 14916.

The tensile adhesive strength is evaluated as

$$F = \frac{P}{A}$$

where

F is the tensile adhesive strength, in MPa;

P is the tensile load, in N, exhibiting a complete failure inside the TBC;

A is the area of the TBC, in mm^2 .

5.3.4.4 Measurement of thermal shock resistance

Figure 10 shows a relationship between the measured tensile adhesive strength and the thermal shock temperature difference.

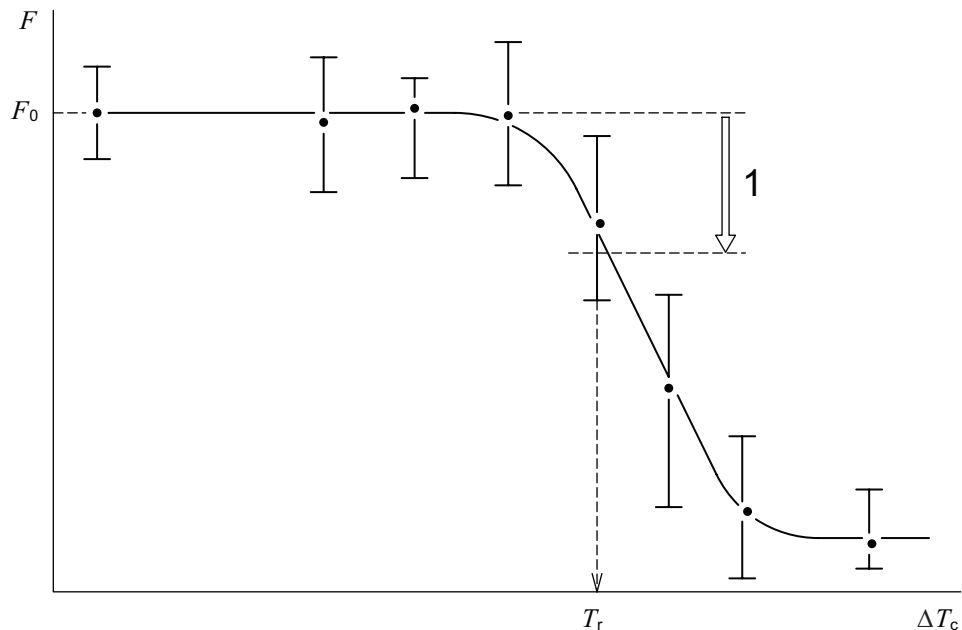

Key

1 30 % down

T_r thermal shock resistance

F_0 tensile adhesive strength in absence of thermal shock

ΔT_c thermal shock temperature difference

F tensile adhesive strength

Figure 10 — Typical correlation between tensile adhesive strength and thermal shock temperature difference

Establish the tensile adhesive strength immediately prior to a decrease in the strength by 30 % relative to the adhesive strength in the absence of thermal shock. T_r represents the thermal shock resistance of the TBC. Additional tests are to be carried out if the data do not fall in the range of 20 % to 30 %.

6 Test reports

6.1 General

The test reports shall contain:

- a) a reference to this International Standard, ISO 14188:2012;
- b) detailed information concerning the substrates and that of the coating materials;
- c) methods of application of coatings;
- d) number of test pieces, their shapes and dimensions;
- e) test temperatures at high and low temperature;
- f) detailed information of test methods;
- g) procedures employed and any deviations from the procedures specified.

6.2 Test report of thermal cycle resistance method

- 1) number of thermal cycles;
- 2) duration period at high and low temperature;
- 3) critical number of cycles to spalling;
- 4) mass loss of test pieces;
- 5) correlation between the number of thermal cycles and ratio of spalling area;
- 6) photographic record of cross-section of the microstructure of the test piece following completion of tests.

6.3 Test report of thermal shock resistance method

- 1) Type of adhesives used for the measurement of tensile adhesive strength;
- 2) thermal shock temperature difference;
- 3) correlation between tensile adhesive strength and thermal shock temperature difference;
- 4) thermal shock resistance.

Bibliography

- [1] ISO 3611, *Geometrical product specifications (GPS) — Dimensional measuring equipment: Micrometers for external measurements — Design and metrological characteristics*
- [2] ISO 13385 (all parts), *Geometrical product specifications (GPS) — Dimensional measuring equipment*
- [3] ISO 80000-1, *Quantities and units — Part 1: General*
- [4] ASTM E527–07, *Standard Practice for Numbering Metals and Alloys in the Unified Numbering System (UNS)*

British Standards Institution (BSI)

BSI is the national body responsible for preparing British Standards and other standards-related publications, information and services.

BSI is incorporated by Royal Charter. British Standards and other standardization products are published by BSI Standards Limited.

About us

We bring together business, industry, government, consumers, innovators and others to shape their combined experience and expertise into standards-based solutions.

The knowledge embodied in our standards has been carefully assembled in a dependable format and refined through our open consultation process. Organizations of all sizes and across all sectors choose standards to help them achieve their goals.

Information on standards

We can provide you with the knowledge that your organization needs to succeed. Find out more about British Standards by visiting our website at bsigroup.com/standards or contacting our Customer Services team or Knowledge Centre.

Buying standards

You can buy and download PDF versions of BSI publications, including British and adopted European and international standards, through our website at bsigroup.com/shop, where hard copies can also be purchased.

If you need international and foreign standards from other Standards Development Organizations, hard copies can be ordered from our Customer Services team.

Subscriptions

Our range of subscription services are designed to make using standards easier for you. For further information on our subscription products go to bsigroup.com/subscriptions.

With **British Standards Online (BSOL)** you'll have instant access to over 55,000 British and adopted European and international standards from your desktop. It's available 24/7 and is refreshed daily so you'll always be up to date.

You can keep in touch with standards developments and receive substantial discounts on the purchase price of standards, both in single copy and subscription format, by becoming a **BSI Subscribing Member**.

PLUS is an updating service exclusive to BSI Subscribing Members. You will automatically receive the latest hard copy of your standards when they're revised or replaced.

To find out more about becoming a BSI Subscribing Member and the benefits of membership, please visit bsigroup.com/shop.

With a **Multi-User Network Licence (MUNL)** you are able to host standards publications on your intranet. Licences can cover as few or as many users as you wish. With updates supplied as soon as they're available, you can be sure your documentation is current. For further information, email bsmusales@bsigroup.com.

BSI Group Headquarters

389 Chiswick High Road London W4 4AL UK

Revisions

Our British Standards and other publications are updated by amendment or revision.

We continually improve the quality of our products and services to benefit your business. If you find an inaccuracy or ambiguity within a British Standard or other BSI publication please inform the Knowledge Centre.

Copyright

All the data, software and documentation set out in all British Standards and other BSI publications are the property of and copyrighted by BSI, or some person or entity that owns copyright in the information used (such as the international standardization bodies) and has formally licensed such information to BSI for commercial publication and use. Except as permitted under the Copyright, Designs and Patents Act 1988 no extract may be reproduced, stored in a retrieval system or transmitted in any form or by any means – electronic, photocopying, recording or otherwise – without prior written permission from BSI. Details and advice can be obtained from the Copyright & Licensing Department.

Useful Contacts:

Customer Services

Tel: +44 845 086 9001

Email (orders): orders@bsigroup.com

Email (enquiries): cservices@bsigroup.com

Subscriptions

Tel: +44 845 086 9001

Email: subscriptions@bsigroup.com

Knowledge Centre

Tel: +44 20 8996 7004

Email: knowledgecentre@bsigroup.com

Copyright & Licensing

Tel: +44 20 8996 7070

Email: copyright@bsigroup.com



...making excellence a habit.™