



BSI Standards Publication

Solid mineral fuels — Guidance on the sampling of coal seams

National foreword

This British Standard is the UK implementation of ISO 14180:2017. It supersedes BS ISO 14180:1998, which is withdrawn.

The UK participation in its preparation was entrusted to Technical Committee PTI/16, Solid mineral fuels.

A list of organizations represented on this committee can be obtained on request to its secretary.

This publication does not purport to include all the necessary provisions of a contract. Users are responsible for its correct application.

ISBN 978 0 580 94120 7

ICS 73.040

Compliance with a British Standard cannot confer immunity from legal obligations.

This British Standard was published under the authority of the Standards Policy and Strategy Committee on 31 May 2017.

Amendments/corrigenda issued since publication

Date	Text affected
------	---------------

INTERNATIONAL
STANDARD

ISO
14180

Second edition
2017-04-01

**Solid mineral fuels — Guidance on the
sampling of coal seams**

*Combustibles minéraux solides — Principes directeurs pour
l'échantillonnage des veines de charbon*



Reference number
ISO 14180:2017(E)



COPYRIGHT PROTECTED DOCUMENT

© ISO 2017, Published in Switzerland

All rights reserved. Unless otherwise specified, no part of this publication may be reproduced or utilized otherwise in any form or by any means, electronic or mechanical, including photocopying, or posting on the internet or an intranet, without prior written permission. Permission can be requested from either ISO at the address below or ISO's member body in the country of the requester.

ISO copyright office
Ch. de Blandonnet 8 • CP 401
CH-1214 Vernier, Geneva, Switzerland
Tel. +41 22 749 01 11
Fax +41 22 749 09 47
copyright@iso.org
www.iso.org

Contents

Page

Foreword	iv
Introduction	v
1 Scope	1
2 Normative reference	1
3 Terms and definitions	1
4 Selection of sampling site	3
4.1 Initial considerations.....	3
4.2 Sampling procedures.....	3
4.3 Core sampling.....	4
4.3.1 Purpose of coal sampling.....	4
4.3.2 Core drilling and sampling procedures.....	4
4.3.3 Core recovery.....	5
4.3.4 Core handling and identification.....	6
4.3.5 Procedure for placing samples in bags.....	6
4.3.6 Procedure for storing and despatching samples.....	6
4.3.7 Boxing of core.....	7
4.3.8 Transporting core.....	8
4.4 Cuttings or “chip” sampling.....	8
4.4.1 Purpose of cuttings sampling.....	8
4.4.2 Method of cuttings sampling.....	8
4.4.3 Cuttings samples identification and labelling.....	9
4.5 Open-cut slot sampling.....	9
4.5.1 Purpose of open-cut slot sampling.....	9
4.5.2 Method of open-cut slot sampling.....	10
4.6 Adit, drift or shaft sampling.....	12
4.7 Pillar sampling.....	13
4.7.1 Purpose of pillar sampling.....	13
4.7.2 Marking of sampling site.....	13
4.7.3 Method of pillar sampling.....	13
4.8 Channel sampling.....	15
4.8.1 Purpose of channel sampling.....	15
4.8.2 Manual sampling in underground situations.....	15
4.8.3 Continuous miner sampling.....	17
4.9 Strip sampling.....	17
4.9.1 Purpose of strip sampling.....	17
4.9.2 Method of strip sampling.....	18
4.10 Total moisture samples.....	18
4.11 Labelling.....	18
5 Recording of sampling location and geological data	18
5.1 Sampling location.....	18
5.2 Geological and sampling data.....	19
6 Transportation of samples	19
6.1 Pillar samples.....	19
6.2 Channel and strip including sub-sectional (ply) samples.....	20
Annex A (informative) Example of a standard form for recording channel sampling data	21
Bibliography	23

Foreword

ISO (the International Organization for Standardization) is a worldwide federation of national standards bodies (ISO member bodies). The work of preparing International Standards is normally carried out through ISO technical committees. Each member body interested in a subject for which a technical committee has been established has the right to be represented on that committee. International organizations, governmental and non-governmental, in liaison with ISO, also take part in the work. ISO collaborates closely with the International Electrotechnical Commission (IEC) on all matters of electrotechnical standardization.

The procedures used to develop this document and those intended for its further maintenance are described in the ISO/IEC Directives, Part 1. In particular the different approval criteria needed for the different types of ISO documents should be noted. This document was drafted in accordance with the editorial rules of the ISO/IEC Directives, Part 2. www.iso.org/directives

Attention is drawn to the possibility that some of the elements of this document may be the subject of patent rights. ISO shall not be held responsible for identifying any or all such patent rights. Details of any patent rights identified during the development of the document will be in the Introduction and/or on the ISO list of patent declarations received. www.iso.org/patents

Any trade name used in this document is information given for the convenience of users and does not constitute an endorsement.

For an explanation on the voluntary nature of standards, the meaning of ISO specific terms and expressions related to conformity assessment, as well as information about ISO's adherence to the World Trade Organization (WTO) principles in the Technical Barriers to Trade (TBT), see the following URL: <http://www.iso.org/iso/foreword.html>

This document was prepared by Technical Committee ISO/TC 27, *Solid mineral fuels*, Subcommittee SC 4, *Sampling*.

This second edition cancels and replaces the first edition (ISO 14180:1998), which has been technically revised

Introduction

Coal is one of the most challenging materials to sample due to its characteristic heterogeneity. A coal seam can consist of a single stratum of one lithotype of relatively uniform maceral constitution, or more commonly, consist of a number of layers of different coal lithotypes varying in thickness and lateral extent. The seam can also contain discrete layers of inorganic sediments or carbonaceous shales of varying thickness. Veins of concordant or discordant secondary mineral rock could also be present. The lithotype layers can vary considerably in hardness, texture and structure according to the nature of the coal and inorganic sediments. The inorganic layers can also thicken laterally, splitting the seam into two or more separate units which could require multiple samples.

It is strongly recommended that a collaborative team including geologists, mining engineers, safety, land and laboratory professionals review each proposed sampling program to help ensure optimal effectiveness and efficiency are obtained.

The purpose of sampling coal for any resource evaluation is to predict the expected quality of the produced coal from a given locale. Therefore, the fundamental goal of each sampling effort is the collection of representative samples of the seam(s) at each sampling location. A properly executed sampling program needs to accurately define both the lateral variation in coal quality and the average quality for a specified area.

After inspection of any seam, the sampler designs a sampling program with sufficient representative samples to define the range of expected coal quality. In variable seams it is necessary to take a number of samples to improve the representativity of sampling.

In operating mines, the manager needs to be consulted and approval needs to be obtained before sampling sites are selected and sampling proceeds. Where there is no operating mine the area or tenement owner and or operator is consulted.

In all sampling situations, experienced and qualified personnel will be required for supervision and to ensure that accurate records are made of location, thickness and lithotype descriptions and that all safety precautions have been addressed.

Methods of sampling for physical, chemical, petrographic or utilization properties are described for the following:

- a) sampling from small and large diameter drill cores;
- b) sampling from exposed seam faces;
- c) sampling from trial open-cut excavations;
- d) sampling from underground workings.

Solid mineral fuels — Guidance on the sampling of coal seams

SAFETY PRECAUTIONS — It is strongly recommended that a risk analysis of the sampling exercise be undertaken by an experienced safety officer before work begins.

1 Scope

This document provides guidance on methods for taking samples from coal seams in the ground, whether from exploration areas or tenements, or from operating underground or open-cut mines. The following methods are described:

- a) sampling of small or large diameter holes;
- b) drill cuttings sampling;
- c) open-cut slot sampling;
- d) adit, drift or shaft sampling;
- e) pillar sampling;
- f) channel sampling;
- g) strip sampling.

This document does not apply to sampling from moving streams in production or any other source of coal that is not *in situ*.

Recommendations are made for selection and preparation of the sampling site, and methods are described for taking both small and bulk samples, and for preparing the samples for transport.

NOTE [Annex A](#) gives an example of a channel sample record form that can be used to record sampling and other relevant data, and ISO 13909 or ISO 18283 describes how to determine the mass of a representative sample at various nominal top sizes.

2 Normative reference

The following documents are referred to in the text in such a way that some or all of their content constitutes requirements of this document. For dated references, only the edition cited applies. For undated references, the latest edition of the referenced document (including any amendments) applies.

ISO 1213-2, *Solid mineral fuels — Vocabulary — Part 2: Terms relating to sampling, testing and analysis*

3 Terms and definitions

For the purposes of this document, the terms and definitions given in ISO 1213-2 and the following apply.

ISO and IEC maintain terminological databases for use in standardization at the following addresses:

- ISO Online browsing platform: available at <http://www.iso.org/obp>
- IEC Electropedia: available at <http://www.electropedia.org/>

3.1
bulk sample

sample of large mass, taken in a particular operation for a specific reason, such as for pilot washing, coal preparation or combustion tests

Note 1 to entry: It is not possible to define the minimum size of a bulk sample.

3.2
channel sample

sample of the coal and associated inorganic material taken by removing a vertical channel of even cross-section from the seam

Note 1 to entry: Where the full section of the seam is not accessible or not required, this term can refer to a sample taken either from a specifically defined portion of the seam, or from the floor to roof as mined or exposed.

3.3
coal seam

stratum or sequence of strata composed of coal as a significant component and significantly different in lithology to the strata above and below it

Note 1 to entry: It is laterally persistent over a significant area and it will be of sufficient thickness and persistence to warrant mapping or description as an individual unit.

3.4
core sample

cylindrical sample of the whole or part of a coal seam obtained by drilling using a coring barrel

Note 1 to entry: The diameter of the core can vary from 50 mm to 2 000 mm depending on the reason for which the sample is required. However, 50 mm to 200 mm is the most common core diameter range.

3.5
cuttings sample

sample of coal chips produced from the rotary drilling of a coal seam using a non-coring bit such as a blade bit or roller bit

3.6
pillar sample

section of a seam taken in the form of a block, or series of blocks, of coal with associated inorganic rock which, when arranged in correct vertical sequence, represent a true section of the seam

Note 1 to entry: Where the full section of the seam is not accessible or not required, this term can refer to a sample taken either from a specifically defined portion of the seam, or from the floor to roof as mined or exposed.

3.7
ply

layer of coal seam normally differing in properties from adjacent layers. Any distinctive layer maybe regarded as a ply

3.8
ply sample

sample taken from an individual ply or leaf or from a series of plies or leaves of a coal seam

3.9
strip sample

sample similar to a channel sample but smaller in cross-section

Note 1 to entry: A single strip sample can often be regarded as being too small to guarantee that all horizons of the seam are adequately represented. However, a number of such samples can be taken to achieve better representativity in a variable seam.

4 Selection of sampling site

4.1 Initial considerations

Sampling sites where possible are chosen at random when no other information regarding the tenement or exploration site is available. The site for sampling apart from drill holes should be chosen, as far as possible, to avoid cracks and breaks, random lenses of rock or mineral matter, or other abnormalities or irregularities in the face to be sampled. However, on occasion, the purpose may be to sample a particular mode of development of the seam section, in which case the sample should be taken at the best available site exhibiting this feature. The location of the sampling point should be recorded accurately (see [Clause 6](#)).

Core sampling is usually employed for sampling coal seams that are not exposed in outcrop or by mining. It is especially useful in areas which are not readily accessible as drill rigs are small enough to be located by helicopter. Sometimes, however, this method is used even though exposed faces are available. This is because it is often faster, less labour-intensive, safer and more representative than pillar or strip sampling, especially if a suitable drilling rig is readily available. For example, many open-cut mines take cores of the seam to be uncovered in the next mining strip to obtain coal quality data for mine planning purposes. Coring of the uncovered coal seam by a drilling rig sitting directly on top of the coal is also common practice where detailed coal quality parameters need to be known for blending purposes or for specific cargoes where the customer may be particularly sensitive to certain coal properties or inorganic impurities.

Cores can be obtained routinely in diameters ranging from 50 mm to 200 mm depending on the amount of material required for testing. It is generally advisable that, for routine sampling operations, 100 mm cores be taken as this size provides a good compromise between representativity and cost.

NOTE There are risks in comparing data from different core sizes of the same coal. The determined yield values and analysis for washing coals can vary significantly. When this occurs it is recommended that the results be confirmed by very large cores as described above or by practices outlined in 5.4.

4.2 Sampling procedures

No two projects are exactly the same and may have different requirements regarding sampling, such as when and what should be sampled, how the sampling should be done, and the details of how the samples should be numbered or identified, wrapped, recorded, stored and treated.

There are a number of rules related to sampling that should be noted:

- a) **Prepare well.** Even if there is little expectation of finding anything of commercial significance, the sampler should always be prepared and in a position to take samples if the opportunity presents. Always have a selection of sample bags, bottles or other containers on hand, in case they are needed.
- b) **Ask questions.** Before embarking on a new project, the sampler should discuss the sampling requirements with the Exploration Geologist and or Manager, so it is clear exactly what is required.
- c) If in doubt, **take samples rather than not.** Samples that are excess or surplus to requirement can always be disposed of later, but if samples are not taken when the opportunity is available, then the chance to do so may be lost completely. Take more samples than you may think are needed, and divide if uncertain about coal ply boundaries. These can always be recombined in the laboratory following geophysical reconciliation.
- d) **Do not put off until tomorrow what you can do today.** For example, if it is late in the day but the project requires that 1m increment soil samples should be collected from the first 10m of the cuttings of an exploration chip borehole, do not leave the cuttings overnight with the intention of collecting the samples the next morning. Do not take the risk that samples could be lost, contaminated or have their integrity compromised.
- e) Care should also be taken to prevent contamination by out-of-seam materials, or other sources such as drilling fluid. In all cases, but particularly for lower rank coals, it is imperative that the

sample be promptly packed in its container to minimize loss of moisture and be transported to the laboratory as soon as practicable.

- f) Before sampling an exposed face, the section to be sampled should, as far as practicable, be uniformly dressed and squared up, and any loose, overhanging or protruding pieces of coal or rock should be removed. Where a face is weathered, the immediate surface material should be removed to a depth sufficient to eliminate weathering effects. In the case of underground face sampling, contamination by stone dust is to be avoided, as this will influence the analysis.
- g) The coal sample after logging and identification should be kept in a sealed bag or container.
- h) If the laboratory cannot begin analysis immediately, arrangements should be made to keep the sample in cold or cool storage to prevent oxidation of the coal. Any coal not being analysed should be returned to cold or cool storage until it is required.
- i) It is critical that sample information is recorded carefully, thoroughly and accurately. There is no value in having a sample that cannot be identified or being able to determine where it came from, or why it was sampled.
- j) It is essential that all samples are analysed using rigid quality assurance and quality control procedures. Examples such as duplicate samples, round robins between laboratories, standard samples, laboratory certification to ISO 17025 are recommended in this document.

4.3 Core sampling

4.3.1 Purpose of coal sampling

Core drilling is used to obtain representative samples for geotechnical, coal quality and gas content and other testing to provide as much information from a borehole as possible. A well drilled and recovered core enables precise detail to be recorded on the thickness and brightness of coal bands and the presence of any inter-bedded rock types such as mudstone, siltstone, or tuffaceous material within a coal seam. It also enables the weathered state of the coal to be identified. The combination of detailed lithology logs with coal quality determinations and other test results, supports the determination of working sections and mining methods, coal handling procedures and products.

4.3.2 Core drilling and sampling procedures

The drilling and sampling of core is an expensive and time consuming process. The information available from logging and testing of core contributes significantly to critical decisions about the quantity and quality of the resource and the potential mining conditions. Cores should be highly valued and treated with appropriate care. Tasks when coring include:

- a) communicate with the driller about the length of the core run, the depth of the borehole, and the condition of the core;
- b) carefully transfer core from driller's splits to PVC splits for logging;
- c) clean drilling mud and cuttings from core surface with as little water and disturbance as possible;
- d) photograph and log all cores as soon as possible after extraction to minimize disturbance to core;
- e) sample coal and partings separately before transferring any material to core boxes, unless significantly different to expected interval or core required for other purpose. In some countries the term used when handling partings and high ash zones is "When in doubt break it out" meaning these zones can be separately sub-sampled, analysed and combined mathematically later. Alternatively the core may be boxed first, logged, and sampled later with the aid of the geophysical logs;
- f) any coal core retained should be stored in core sock (plastic tubing) or similar protective covering to minimize moisture loss and further disturbance;

- g) minimize evaporation of moisture from coal samples by not leaving exposed for an extended period, sealing samples into plastic bags, and keeping sample bags out of direct sunlight.

4.3.3 Core recovery

There are a number of aspects for good core recovery that should be considered as follows:

- a) The mechanical state of the rock, the driller and the drilling methods utilized, and the condition and operation of the coring equipment. It is possible to obtain 100 % core recovery if these factors are all favourable but this is not usual in many situations.
- b) **The difference between what is cored and what is recovered needs to be reconciled.** The first step in the core logging process is to measure the length of core recovered.
- c) **The rig geologist should accurately determine the borehole depth** before the core is pumped out of the barrel, and be responsible for the measurement of the drilled core run intervals. The rig geologist should ask the driller for the length of the drilled run before the core run is extracted from the core barrel. Once the core is pumped out of the barrel, **the length drilled can then be compared with the recovered length**; Significant differences between the drilled length and the recovered length may be due to measurement or calculation error of the amount drilled, or due to core loss. Therefore all measurements should be rechecked and frequent checks of the driller's depth should be made.
- d) Once the core is on the logging table, the rig geologist should make the best attempt possible to close up any gaps, crushed zones and irregularities (e.g. rotate the defect/break for a best fit), or zones of apparent core expansion due to swelling clays or bulking due to discing or mechanical disturbance. The rig geologist should also try to identify the top of the run. **The core should not be manipulated to fit the drilling interval.**
- e) The core should then be measured by both the driller and the rig geologist to obtain the measured **recovered length** of core which should then be recorded on the **Drilling Sheet** with the driller to depth and the geologist to depth. The difference between the length drilled and the **recovered length** is the 'core loss' or 'core gain'.
- f) The apparent expansion of core can of course occur in combination with real core loss. It then becomes difficult to know how much real core loss to assign to versus reducing core length for the cumulative effects of core expansion. Also, although core lost from one core run may be recovered later, each subsequent core run can also be subject to discrete core loss and this should be allocated accordingly.
- g) **The core run information is best recorded as a comment on the *Lithology Sheet* or separate recovery sheet** and should contain the run number, the start of run depth (SOR), end of run depth (EOR), drilled core length and recovered core length. For example: "Run 1: 18.00m to 22.50m, drilled 4.50m, rec 4.32m". A record could also be calculated and recorded of the loss or gain for each core run and the cumulative loss or gain (from values collected on the **Drilling Sheet**).
- h) Where it is difficult to identify where the loss or gain has occurred, a continuous record of the core depths or thicknesses could be made. Any indications of where core loss has occurred should be recorded and depths adjusted later.
- i) Some countries for their geotechnical use also calculate rock quality determinations (RQD) at the same time as core recovery.
- j) Some countries also carry out **full scale geophysical logging** of cores to provide an accurate seam thickness to confirm core recovery and provide information regarding variation in ash in the seam. The data obtained can also assist in the final sampling of the core.

4.3.4 Core handling and identification

Before samples are sent to the laboratory, the following procedures should be followed to ensure the highest possible standard and reliability of sample collection and analysis:

- a) Ensure all samples are taken as soon as possible to minimize moisture loss, otherwise store coal in core sock or with plastic cover.
- b) Minimize inclusion of excess free moisture minimize damage to core when separating samples.
- c) Recover all possible core with minimal contamination.
- d) Use a brush to ensure all possible fines are retained.
- e) It is recommended that each sample should also be given a unique number within a sequential numbering system, preferably commencing with the first sample of the uppermost seam in the hole. Record project name, borehole name, and sample number with a water proof pen on the outside of each bag – sample depths may also be included.
- f) Record bag number (as bag x of xx) if multiple bags used for sample interval.

4.3.5 Procedure for placing samples in bags

This procedure should include:

- a) double bag all samples (in tough {i.e. >60um} plastic bags);
- b) include a sample tag with sample number in outer bag;
- c) seal bag as air tight as possible with tape or cable ties;
- d) weigh and record all bagged samples;
- e) keep samples in shady or cool area if possible;
- f) transfer all samples to cold or cool storage at end of day if possible;
- g) consider using a bar code system for identifying all samples.

4.3.6 Procedure for storing and despatching samples

This procedure should include:

- a) pack sample bags into larger poly sacks (<25kg) or 200 l drums (see [Figure 1](#));
- b) seal securely (cable ties, staples, tape or secured lid);
- c) label outside with project name, borehole name, sample numbers and bag/drum number with a water proof pen or paint;
- d) keep physical or digital record of all sample bags/drums with contents;
- e) transfer all samples to cold or cool storage awaiting despatch if possible;
- f) samples should be dispatched to the laboratory as soon as reasonably possible (recommend at least once per week);
- g) prior to despatch, the laboratory should be informed in writing of the number, identification and dispatch weight of all samples and numbers of drums and or bags that is to be delivered; a copy of the sample record sheets shall be provided to the laboratory;
- h) record date of despatch; and

- i) when the laboratory staff receives the samples in the laboratory they shall ensure they reconcile them against the sample record sheets and weigh each sample received; this ensures that all samples are received and if any bag is ripped the sample loss can be determined.



Figure 1 — Typical polypropylene sacks

4.3.7 Boxing of core

If core is to be stored for later inspection and sampling it should be placed in appropriate core boxes or trays. All core boxes should be labelled on the front and one end from left-to-right so they can be read in racks, with the following:

- a) project name;
- b) borehole number;
- c) box number;
- d) and from and to depths (of the core in the box);

Suitable markers (e.g. wood or polystyrene block) should be placed inside the box as follows:

- at the top left with the borehole number, box number, and core start depth;
- at the end of each run with letters 'EOR' (end of run), run number, and depth;
- at the start of a new run where not continuous from previous run with letters 'SOR' (start of run), run number, and depth;
- where a sample has been taken with sample number and to and from depths (marker does not need to match size of sample);
- where core loss has been recorded;
- and at the bottom right with the end of core (EOC) or total depth (TD) of the borehole.

Position the core in a box in a way that minimises manual handling and core damage. It is recommended that additional blocks are placed into gaps in the core trays to stop the core moving during transport. Broken or fragmented core may be rolled into an appropriate length of PVC split tubing to ensure integrity in transfer to the core box, and during transport and storage. If the core has been sampled the residual core should be stored and clearly identified as being sampled. [Figure 2](#) shows an example of the correct layout of core in a core box. This shows that details such as project name (removed from this figure), borehole name (removed from this figure), box number and depths can also be written on the edges of the box. Note that breaks have occurred in the core during boxing or transportation as they are not marked.

4.3.8 Transporting core

While on site, core boxes should be located so they are easily accessed and securely stored where they will not be affected by weather or other disturbance. Position the box in a manner that prevents any chance of the core box falling or the core being uncovered.

Core boxes should be secured and transported to a core shed and stored appropriately as soon as possible. Strap core boxes into a vehicle to avoid movement and reduce the safety hazard during transit.

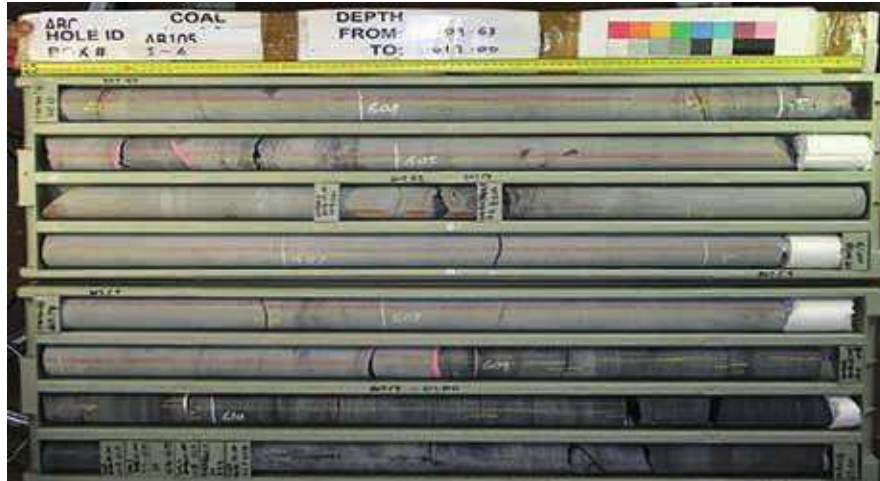

Figure 2 — Typical core box

4.4 Cuttings or “chip” sampling

4.4.1 Purpose of cuttings sampling

Cuttings or chip sampling is used where core sampling is not possible or not justified in terms of cost. Cuttings samples shall not be considered as representative compared to core samples although technological advances have made both core and cuttings samples more reliable. They require a great deal of experience on the part of the driller and sampler to obtain reasonable samples but should never be accepted as being truly representative of the coal seam. An instance in which cuttings samples might be adequate would be in the early stages of an exploration area or tenement evaluation where an indication of coal quality is required as a precursor to more detailed core sampling.

4.4.2 Method of cuttings sampling

Open hole drilling can be accomplished utilizing two non-coring techniques, Rotary Air Blast Drilling (RAB) and Reverse Circulation Drilling (RC). RAB drilling utilizes a single wall drill pipe, with a variety of cutting bits at the downhole end, and acts by injecting either air or drilling fluid down through the drill pipe, and recovering drill cuttings as they are flushed out at the top of the hole, having travelled up hole in the annulus between the drill pipe and the wall of the hole. RC drilling utilizes double walled drill pipe, creating a “pipe within a pipe”, and acts by injecting either air or drilling fluid down the outside pipe, and returning the drill cuttings to the surface through the inner pipe. RC drilling is preferable to RAB drilling as the drill cuttings are not mixed and contaminated by the wall rock as they travel up the hole as is the case with RAB, with RC samples therefore being more representative of the strata the drill bit has penetrated.

The size of the cuttings can be very variable but generally ranges from a few millimetres to a few centimetres. As the drill bit advances through the seam, the circulating medium (air, water or drilling mud) transports the cuttings from the bit to the surface and they are collected in a purpose-made container or cyclone or on a shovel held near the hole. Generally, the driller alerts the sampler when a coal seam is intersected, and stops drilling while still circulating the drilling fluid to clear the hole as much as practical of out-of-seam contamination. When satisfied that the hole is clear, the driller then

drills a previously agreed distance, usually one metre, while the sample is collected, and then cleans out the hole again. This procedure is continued through the seam until the seam floor is encountered.

A qualified and well trained sampler or geologist should log all chip samples after washing by sieving in a bucket of water to remove dust or drilling fluid, except for some intervals of weathered or clayey material, as they may not remain in the sieve after being immersed in water. Washing will help to reveal colour variations, grain size, the presence of minerals, and possibly defects such as joint surfaces. This also assists with determining percentages of multiple rock types. Log all chips in the same state to provide consistency of colour descriptions which will appear different if wet or dry. This is likely to be a wet condition if they are logged immediately after washing them, however if some dry out then they should be made wet again. This should also be recorded.

NOTE Be observant and record any contaminant present within the chip samples. Rubber for instance is an indication that the interior of the high pressure bull hose has started to disintegrate. Drilling is to be terminated immediately and the bull hose replaced before drilling can recommence.

NOTE Small cutting samples are less representative compared to full core samples.

The sampler is responsible for labelling each bag of material collected with a drill hole number and depth at which the material was extracted. A variation on conventional cuttings retrieval is the technique of reverse-circulation drilling. In this drilling method, the normal circulation of the drilling medium (down the centre of the drilling rods and back up the annulus between the rods and wall of the hole) is reversed and the drilling fluid is pumped down the annulus, entrains the cuttings, and returns up the centre of the rods, from which the cuttings are recovered and sampled.

Foundation drilling rigs can be used to collect very large cuttings samples, generally on a whole-seam basis, where a large quantity of coal is required for utilization testing or any other purpose. Again, the sample is placed directly in a truck, or on a prepared surface for loading later onto a truck with a front-end loader or similar machine. Sizing of coal obtained in this way can be finer than the anticipated run-of-mine coal sizing, but techniques such as reaming may be used to increase the average size if this is important.

Another type of cuttings sampling is known as “keyhole sampling”. This method involves the fracturing of the coal by blasting in the hole, or reaming followed by the recovery of the broken coal by circulating the drilling medium using hydraulic mobilization and lifting. This method is best suited to sampling deep coal seams that are targeted for underground mining, as an alternative to taking a number of conventional large-diameter cores.

4.4.3 Cuttings samples identification and labelling

Identification and labelling for cuttings samples is similar to the method described for core samples in 5.2.3. If the samples are of small mass then a number of cuttings samples held in small plastic bags and suitably tagged can be placed in larger plastic bags or drums for ease of transport.

4.5 Open-cut slot sampling

4.5.1 Purpose of open-cut slot sampling

Slot sampling is a form of bulk sampling used to acquire a large quantity of coal that would be representative of run-of-mine coal from undeveloped deposits amenable to open-cut mining, or undeveloped areas or seams of an existing open-cut mine. Normally before this form of sampling is undertaken core or cores would be taken to determine coal quality and the depth of coal oxidation.

Often the purpose is to confirm coal quality, sizing, washability and utilization behaviour, on a pilot or full scale coal preparation plant, or in a commercial trial to predict quality for investment purposes. Results from these tests are more reliable than those obtained from core or channel samples and contribute substantially to a development decision and planning.

It is imperative to realize that this type of sampling is subject to relevant legislated acts and regulations and normally can be carried out only with all appropriate authorizations in place and under the direction of suitably qualified mining personnel.

It is necessary that all safety issues and environmental concerns shall have been adequately considered and resolved before sampling is commenced.

4.5.2 Method of open-cut slot sampling

Slot sampling requires a full mine design produced by qualified and experienced civil or mining engineers and geologists. Detailed slot design is outside the scope of this document and only general concepts will be discussed.

Factors to be considered in the overall design of the slot include shape, seam dip and depth, ramp grade and width, side-wall and end-wall angles, water management, and topsoil and spoil pile management.

The size of the slot and therefore the complexity of design will depend on the depth to fresh coal, the thickness of the coal seam to be sampled and the size of the sample required. Thus, the first decision to be made is the quantity of coal required for the purposes for which the sample is being taken. This is influenced by mining and preparation factors such as mining loss, dilution from mining, expected yield of clean coal after washing and whether subsequent samples are required. The quantity of finished coal product is the basis upon which the whole mine plan is based. The depth to coal and the strength of the overburden are particularly important factors in design because they dictate the type of slot that can be used and hence the cost involved.

Where the coal is relatively shallow and the overburden can be removed by scrapers, the preferred slot design is a double-ramp design as shown in [Figure 3](#). In this design, the scrapers remove the overburden down to the top of the coal seam and uncover sufficient coal to produce the amount of finished product that was determined before excavation commenced. This type of slot has the advantage of being easily enlarged later, if more material is required. One common strategy is to uncover twice the width of coal required and mine only half the width using an excavator sitting on the half that is not to be mined. This allows recovery of a similar quantity later for further testing.

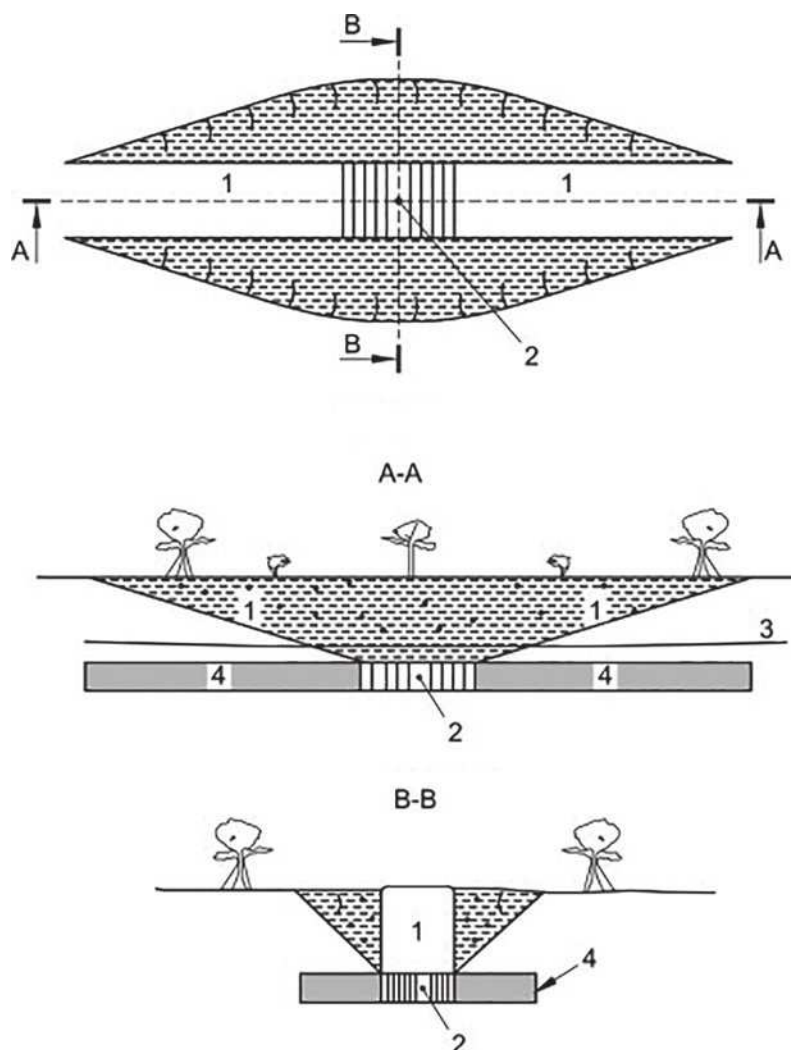

Key

- 1 ramp
- 2 sampled coal
- 3 base of weathering
- 4 coal seam

Figure 3 — Slot bulk sample excavation

Where the strength of overburden or the depth to fresh coal prohibits the use of the double-ramp method, a single ramp is excavated down to the floor of the seam in such a way that sufficient coal is exposed as a block ahead of the ramp, as shown in [Figure 4](#).

In both types of slot, the coal block to be mined is carefully squared up so that a full seam section is available for mining and it is then drilled and lightly blasted, if required, or ripped with a bulldozer. The coal can then be mined with an excavator sitting on the unblasted block and either placed on a clean pad on that block or loaded directly into trucks for transport to the surface for stockpiling and blending, again on a specially prepared pad to minimize contamination.

It is recommended that several channel samples, as described in 5.7 be also taken. The results can then be averaged and compared to the analysis of the bulk sample.

SAFETY PRECAUTIONS — — Note that excavations of this type represent a potential safety hazard and, if they are to remain open, should be securely fenced to prevent entry to humans and wildlife. Adequate use of warning signs is also necessary.

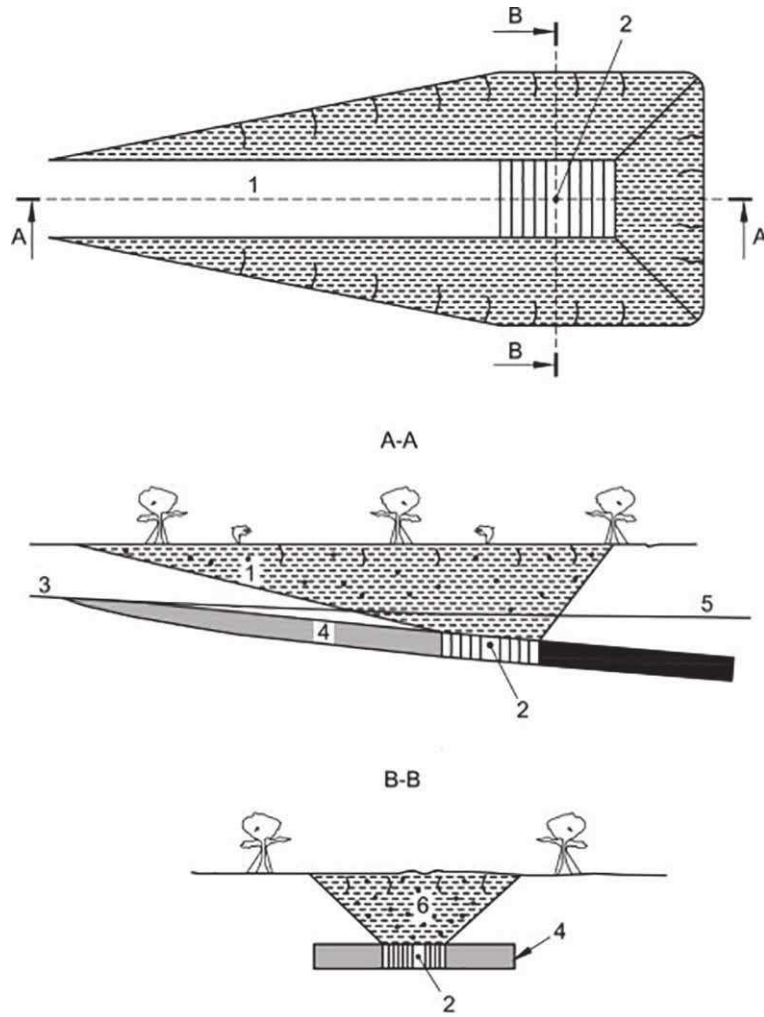

- Key**
- 1 amp
 - 2 sampled coal
 - 3 sub-crop
 - 4 coal seam
 - 5 base of weathering
 - 6 end wall

Figure 4 — Boxcut bulk sample excavation

4.6 Adit, drift or shaft sampling

An adit, drift or shaft may be more appropriate than an open-cut slot for obtaining large samples from coal seams having greater overburden cover or for seams outcropping in cliff faces or exposed in an open-cut mine. Normally before this form of sampling is undertaken core or cores would be taken to determine coal quality and the depth of coal oxidation

An adit is driven into the coal seam outcrop, either by mining machinery or by hand excavation, to reach unweathered/unoxidized coal. The affected coal is discarded. The required coal sample is obtained by continuing mining. Smaller channel or strip samples may be taken at intervals along the adit to determine coal quality before the larger bulk sample is mined. This form of excavation and sampling may cause significant safety issues during sampling so a full mandatory risk assessment is recommended prior to any sampling.

A cross-measures drift may be driven or a vertical shaft may be sunk to intersect deeper coal seams.

As for open-cut slot sampling, these methods are likely to require permits before commencing, and should be supervised by suitably qualified mining personnel.

When sampling in mine sites and or underground situations the sampler shall be aware of and follow all mine regulations. Meetings to discuss sampling exercises should be held with mine managers and or appropriate supervisors prior to any sampling being undertaken so that all local regulations are complied with.

4.7 Pillar sampling

4.7.1 Purpose of pillar sampling

The main purpose of pillar sampling is to provide large, generally intact samples for detailed observations in the laboratory or field office, and for conducting laboratory strength and shear box testing for definition of geomechanical properties.

Pillar sampling of complete, continuous sections of a coal seam can be limited by soft, friable coal, hard, fractured coal, or coal containing hard, non-coal bands. If permitted by mine regulations, in underground situations it can be facilitated by the availability of compressed air tools and a chain saw to obtain relatively smooth pillar surfaces.

Before pillar sampling is attempted, it is essential that:

- a) a suitable location is available;
- b) the sample can be extracted efficiently and safely; and
- c) no safety environmental hazards are created.

4.7.2 Marking of sampling site

Two parallel vertical chalk lines or other suitable markings should be made on the dressed face of the seam from floor to roof, at least 400 mm apart and as far apart as necessary to obtain the required volume of sample. The coal and other material between these lines should form the pillar sample, which should be of sufficient depth to give an area in the bedding plane that will yield the required volume or mass of sample.

4.7.3 Method of pillar sampling

The sample may be obtained by one of the following methods, as shown in [Figure 5](#).

- a) The sample is taken by cutting into the face at an angle on each side of the chosen and marked sampling position, thus isolating a triangular pillar from the face. This may be freed by cutting into the roof and undercutting the floor, and the sample is then removed either en bloc or in sections as described in c) below.
- b) Channels are cut on the outside of the markings, leaving a standing pillar of sufficient cross-section to obtain the required sample size. Working in the channels will enable the back of the pillar to be cut free from the seam. The pillar may then be freed from the roof and, if sufficiently stable and of suitable size and mass, removed en bloc after undercutting from the floor; Should the pillar show signs of instability or tend to collapse, it may be suitably supported so that it can be removed. Should the pillar be too high or fragile to remove in one piece, it may be removed in plies or subsections as described in c) following.
- c) Channels are cut on the outside of the marking as in b) and the pillar material removed in plies or subsections. Where this occurs it should be freed from the roof and the plies or subsections wedged off, wherever possible along the bedding planes, in sequence, from the roof to the floor. As each piece is removed, a mark should be placed on its upper surface and a label prepared giving

its position in relation to the rest of the sample. The label should be enclosed with the piece as it is wrapped. Immediately after each piece is obtained, it should be placed in the sample box (see 6.1) for safe transport.

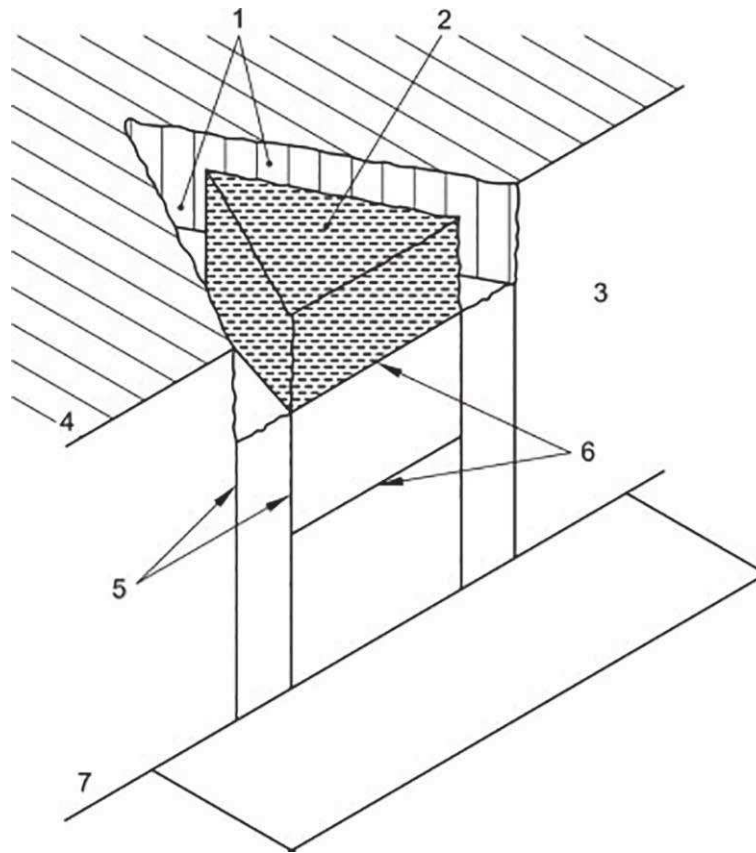

Key

- 1 channel cuts to expose triangular pillar
- 2 pillar of upper ply ready for extraction
- 3 base of upper ply to be cleaned smooth after pillar section is removed
- 4 seam roof
- 5 vertical marks
- 6 subsection sample markers
- 7 seam floor

Figure 5 — Pillar sampling

It may be necessary to obtain overlap of some of the blocks to overcome problems such as fragility or difficulty of separation at certain horizons. Careful measurement at all stages in the removal of blocks from the seam permits a true pillar section to be reconstructed in the laboratory from the overlapping pieces. Where possible photographs of the seam before, during and after sampling should be taken for records. A pillar sample enables a division into plies or subsections to be made after careful examination in good light. This is an advantage where a seam shows marked changes from ply to ply, or contains carbonaceous shale and shaly coal bands, which may not be readily distinguishable where the lighting is not satisfactory for accurate observation.

4.8 Channel sampling

4.8.1 Purpose of channel sampling

Channel samples enable relatively large samples, representative of a full seam at the location or an individual sub-section at the location, to be taken. Channel samples can be taken manually or using mining equipment. With the latter method, representation of the various layers in the seam may not be as certain as with a properly taken hand-mined sample. However, the preparation of the sample to coal preparation plant size is much easier and more certain. Channel sampling is shown in [Figure 6](#).

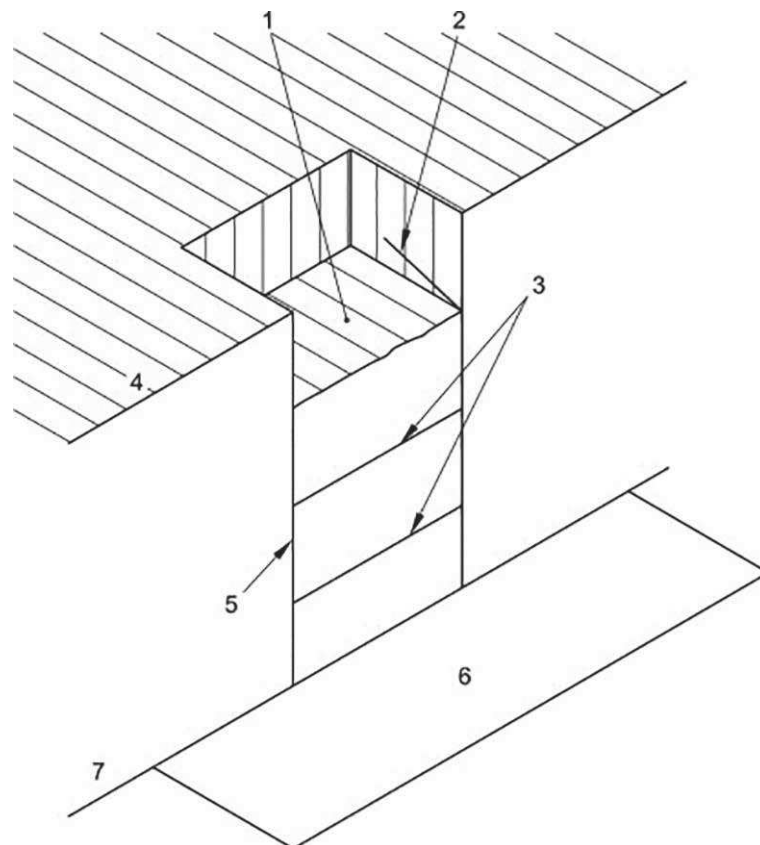

Key

- 1 cleaned-up bedding plane marking the base of ply sample
- 2 seam dipping into face
- 3 marks along bedding to indicate sub-sectional sample intervals
- 4 seam roof
- 5 vertical marks to outline channel
- 6 plastics sheet or brattice cloth
- 7 seam floor

Figure 6 — Channel sampling

4.8.2 Manual sampling in underground situations

The following points needed to be noted for underground situations:

- a) Typically in many underground situations the walls have been “chalked” or “stone dusted” and this needs to be removed before sampling commences.
- b) Ensure that there is water available nearby the sampling location.

- c) The sampler should ensure they have a length of hose approximately 20 m in length with the correct fittings.
- d) The sampler, before any sampling takes place, should then hose down roof to floor and a couple of meters either side of the sampling location. Hose fittings vary so it is important that the sampler confirms what fittings are required before they attend the site,
- e) It is recommended that the sampler keeps a range of the most commonly used air and water fittings along with a tool kit including pneumatic oil for minor repairs and refills.
- f) It is recommended that the sampling location is chosen adjacent to a cut through, as these are identifiable and generally have survey marks in the roof which that can then be used to measure in-by or out-by distances to the sampling location.
- g) The seam thickness at the sampling point should be measured before and after sampling the channel.
- h) Two parallel vertical yellow crayon lines or other suitable markings that do not wipe or wash off should be made on the dressed face of the seam from roof to floor, as far apart as necessary to obtain, in relation to the proposed depth of cut, a sample of the required mass and particle size.
- i) If sub-sectional or ply samples are required, the vertical intervals should be marked at previously agreed points along the bedding plane between the two vertical marks, to facilitate their successive removal as the channel is excavated in sections down to the floor or the base of the selected section, as appropriate.
- j) A channel sample may be taken as follows:
 - 1) by removing a vertical channel of even cross-section down the full height of the seam from roof to floor or from a specifically defined portion of the seam. A large sheet of brattice cloth or plastics material (e.g. PVC) should be placed on the floor against the face and below the channel to collect the sample(s) as excavated;
 - 2) excavated progressively from the roof down to the required depth from the face, forming relatively smooth, even sides over sufficient cross-sectional area to yield the required sample volume, using a miner's pick, or preferably, a mattock having a presharpended blade and point. Where sub-sectional plies are to be taken, the excavation is continued to the bedding plane at the base of the sample interval and the channel sides and basal plane are excavated smoothly, taking care not to cut below the selected plane. The sub-sectional sample is then transferred from the floor sheet into the sample container;
 - 3) In an adaptation of the methods described for taking pillar samples (see 4.6.3). In this way, a more coarsely graded sample can be obtained. The material chipped from the two cuts on either side of the pillar should be discarded, and only the material removed from the central pillar used in the sample. In this method of cutting, care is required to maintain a uniform lateral section of sample as the excavation progresses downward. This method usually provides the best means of securing relatively thin ply samples.
- k) The dimensions of the lateral section through which the channel is cut will depend, for a given height of sample, on the sample mass required and the bulk density of the coal, which may be taken as the apparent relative density of the raw, *in situ* coal.
- l) The channel sampling method should also be used for obtaining intermediate-sized bulk samples from trial open-cut excavations, to ensure that the sample is fully representative of the seam or a particular seam section. Samples should not be taken from the spoil piles of the trench, because they will yield a disproportionate amount of coal from the upper part of the seam by virtue of the shape of the excavation.
- m) Channel sampling is facilitated by having a large selection of tools available to enable cutting of the channel to yield smooth faces, together with a sample having a large nominal top size with the minimum of fines. To greatly assist this sampling, mechanical equipment, such as air pressure

operated chain saws with tungsten carbide chains (no oil) may be used. A typical example of this is outlined in [Figure 7](#).



Figure 7 — Typical air pressure operated chainsaw
Courtesy of SGS Australia Pty Ltd

4.8.3 Continuous miner sampling

Ranging drum-type continuous miners can be operated so that they will cut a channel of uniform depth over the normal working height in a coal seam, and thus provide a channel sample. An experienced driver can usually judge the depth of cut required so that the sample can be accommodated in a single shuttle car. The coal may then be discharged through the breaker feeder, if used, and spread on the panel belt for sub-sampling.

The face should be squared up to remove the possibility of contamination of the sample by protruding top coal or other coal. The floor should be cleaned up and examined so that it can be confirmed that mining is to the true floor. The shuttle car and feeder breaker should be examined and any loose coal that could fall into the sample removed.

The continuous miner is then driven to the appropriate depth and a uniform vertical cut made. The floor should be cleaned of all cut coal, and the shuttle car and feeder breaker examined when emptied. It is preferable to aim for a 75 % full shuttle car so that any error in judgement of the channel depth will not result in spilling part of the sample.

In this method with a shuttle car, a primary sample of approximately 5 t can be taken. The effect of accidental contamination on a sample of this size should be small. However, in a seam with dirt banding of variable thickness, the site of the cut should be carefully examined and any local peculiarities in dirt-band thickness should be noted.

4.9 Strip sampling

4.9.1 Purpose of strip sampling

Strip samples can be described as small pillar or channel samples in which equal representation of all horizons in a seam is attempted, but may not be achieved as successfully as in the larger 400 mm pillar or channel samples. In a variable seam. It does allow the taking of a number of samples for the same effort as one large sample. The coal obtained will still allow the preparation of a product containing 40 % to 60 % of particle size $-22,4$ mm $+16$ mm, at which sizing the ash release will be similar to that obtained in normal coal preparation. Results from a number of such samples will give a better idea of average production from this variable seam, and its potential variability, than a single large pillar or channel sample.

4.9.2 Method of strip sampling

Strip samples should be taken on a ply, or part-ply, basis with the thickness recorded. Wherever possible, a sampling site is selected where cleat development allows breaking up each ply or part thereof to obtain a small pillar of 200 cm² to 300 cm² cross-section. These are not necessarily in the same across-seam line, but can be offset if cleat development makes this preferable. Sites having abnormally high or low concentrations of mineralization on the cleat, however, should be avoided.

Where the coal is badly fractured, a similar cross-section should be broken up into pieces as large as possible. The pieces should be collected on plastic sheeting laid on the floor or held immediately below the sampling horizon. These "ply samples" are placed in bags separately and labelled.

When received in the laboratory, the apparent relative density of each separately sampled layer is normally determined. This procedure allows the representation of each ply in any whole-seam or part-seam composite to be adjusted on a thickness times relative density basis, by trimming, or by sampling after the first crushing. Where dirt bands show major variation in thickness, their representation can be adjusted to average thickness if so desired.

Combination of these adjusted quantities provides a reasonably representative section of the seam at the point of sampling.

4.10 Total moisture samples

Where samples are required for the determination of total moisture, increments should be placed in bags immediately after sampling and sealed progressively to ensure that the sample does not lose any moisture during handling.

4.11 Labelling

All individual samples should be labelled in duplicate with the following data:

- a) job description;
- b) type of sample, e.g. pillar, strip;
- c) sample number;
- d) seam designation details;
- e) sample depth interval and sample thickness;
- f) date of sampling;
- g) weight of sample.

One label should be placed inside the sample container in a plastic bag and one should be securely fastened outside for ready identification. Labels should be enclosed in waterproof, dustproof envelopes unless metal tags are used. Aluminium should not be used underground.

5 Recording of sampling location and geological data

5.1 Sampling location

The location of the sampling should be noted. The following details may be recorded:

- a) mining tenement number and name;
- b) drill hole number(s), if relevant, or distance and bearing to the nearest drill hole;

- c) cadastral details (county, parish, portion or lot), if relevant location coordinates, preferably on the statutory mine grid, or on a specific map grid;
- d) location elevation, preferably related to the height datum, with respect to the floor or roof at the sample point;
- e) for underground coal seam samples, reference may be made to the nearest heading/cut-through intersection in a given panel within a given district of the mine.

NOTE Where no surveyed location is available, the sampling point is referred by bearing, distance and level to a fixed and recognizable feature likely to be shown on maps or plans.

5.2 Geological and sampling data

An accurate geological description (and sampling data log) should be made of the seam section at the sample location, and may include the following:

- a) details of the nature and thickness of individual coal lithotypes, in terms of proportions of dull and bright coal, and interbanded inorganic sediments and secondary minerals;
- b) a geological description of the roof and floor strata;
- c) details of the sample intervals and estimated masses of samples (depths at top and base, thicknesses related to sample number), seam thickness; where sub-sectional (ply) samples are taken, it is necessary to check that the sum of individual ply thicknesses equals the total thickness of the seam section sampled, before leaving the site;
- d) name of sampling organization;
- e) name of sampler;
- f) date sampled;
- g) date and mode of transport;
- h) destination; and
- i) purpose of sample.

The data in [6.1](#) and [6.2](#) should be recorded systematically at the sampling point.

NOTE [Annex A](#) gives an example of a suitable record sheet for channel sampling.

6 Transportation of samples

6.1 Pillar samples

Strong wooden or metal boxes should be provided for the packing and transportation of pillar samples. Wooden boxes should be made of strong (25 mm) timber with reinforced corners, and battens on the bottom. The boxes should be of a size that can be handled without undue effort and accommodated in an ordinary mine skip or shuttle car.

The lid should be arranged for fastening by means of screws or at least four wing nuts and bolts, the latter being screwed to the inside of the box and the lid having holes drilled in the correct position. The lid should be clearly marked with the words "THIS SIDE UP WITH CARE".

Rope or batten handles should be fastened to the end to assist in handling.

Pillar samples should be packed before despatch from the sampling site in a manner that will minimize breakage while the sample is being transported out of the mine and to the laboratory.

6.2 Channel and strip including sub-sectional (ply) samples

Channel and strip samples should be packed in clean robust sample bags and, especially for transport via railways or road, should in turn be packed in airtight metal 20 l, 50 l or 200 l drums having removable clamp lids with rubber seals. Bags and drums should be packed as tightly as possible to reduce air to a minimum. Where more than one bag or drum is used per sample, the sample labels should include the bag number and total number of bags, e.g. bag 1 of 3. The outside of the container should be clearly marked in a similar manner.

Annex A (informative)

Example of a standard form for recording channel sampling data

The form illustrated in this annex is presented as an example of a format for recording channel sampling data. It is intended for use at the sampling site.

Bibliography

- [1] ISO 13909, *Hard coal and coke — Mechanical sampling*
- [2] ISO 17025, *General requirements for the competence of testing and calibration laboratories*
- [3] ISO 18283, *Hard coal and coke — Manual sampling*
- [4] AS 2519: 1993, *Guide to the technical evaluation of higher rank coal deposits; Standards Australia*
- [5] AS 2617:1996, *Sampling from coal seams Standards Australia*

Some text and Photographs extracted from ACARP Project Number C22017 with permission CoalLog Geology and Geotechnical Training Manual edited Mr David Green Australia.

- [6] ASTM MANUAL ON DRILLING. In: Sampling and Analysis of Coal ASTM MNL11 PCN28-011092.13. (LUPPENS J.A. ed.). S.E Wilson and R.W Stanton USA
- [7] COALLOG GEOLOGY AND GEOTECHNICAL TRAINING MANUAL. In: ACARP Project C22017. (GREEN D. ed.). Australia, January 2015
- [8] Sampling of Coal Seams GB 482 Peoples Republic of China
- [9] Guide to Borehole Core in the Karoo Basin Coalfields South Africa reference. Coaltech 20 20 by B.Cairncross
- [10] Standards of Disclosure for Mineral Projects Canada N143-101 has sections on geology, sampling, recovery, quality control, and transportation

About us

We bring together business, industry, government, consumers, innovators and others to shape their combined experience and expertise into standards-based solutions.

The knowledge embodied in our standards has been carefully assembled in a dependable format and refined through our open consultation process. Organizations of all sizes and across all sectors choose standards to help them achieve their goals.

Information on standards

We can provide you with the knowledge that your organization needs to succeed. Find out more about British Standards by visiting our website at bsigroup.com/standards or contacting our Customer Services team or Knowledge Centre.

Buying standards

You can buy and download PDF versions of BSI publications, including British and adopted European and international standards, through our website at bsigroup.com/shop, where hard copies can also be purchased.

If you need international and foreign standards from other Standards Development Organizations, hard copies can be ordered from our Customer Services team.

Copyright in BSI publications

All the content in BSI publications, including British Standards, is the property of and copyrighted by BSI or some person or entity that owns copyright in the information used (such as the international standardization bodies) and has formally licensed such information to BSI for commercial publication and use.

Save for the provisions below, you may not transfer, share or disseminate any portion of the standard to any other person. You may not adapt, distribute, commercially exploit, or publicly display the standard or any portion thereof in any manner whatsoever without BSI's prior written consent.

Storing and using standards

Standards purchased in soft copy format:

- A British Standard purchased in soft copy format is licensed to a sole named user for personal or internal company use only.
- The standard may be stored on more than 1 device provided that it is accessible by the sole named user only and that only 1 copy is accessed at any one time.
- A single paper copy may be printed for personal or internal company use only.

Standards purchased in hard copy format:

- A British Standard purchased in hard copy format is for personal or internal company use only.
- It may not be further reproduced – in any format – to create an additional copy. This includes scanning of the document.

If you need more than 1 copy of the document, or if you wish to share the document on an internal network, you can save money by choosing a subscription product (see 'Subscriptions').

Reproducing extracts

For permission to reproduce content from BSI publications contact the BSI Copyright & Licensing team.

Subscriptions

Our range of subscription services are designed to make using standards easier for you. For further information on our subscription products go to bsigroup.com/subscriptions.

With **British Standards Online (BSOL)** you'll have instant access to over 55,000 British and adopted European and international standards from your desktop. It's available 24/7 and is refreshed daily so you'll always be up to date.

You can keep in touch with standards developments and receive substantial discounts on the purchase price of standards, both in single copy and subscription format, by becoming a **BSI Subscribing Member**.

PLUS is an updating service exclusive to BSI Subscribing Members. You will automatically receive the latest hard copy of your standards when they're revised or replaced.

To find out more about becoming a BSI Subscribing Member and the benefits of membership, please visit bsigroup.com/shop.

With a **Multi-User Network Licence (MUNL)** you are able to host standards publications on your intranet. Licences can cover as few or as many users as you wish. With updates supplied as soon as they're available, you can be sure your documentation is current. For further information, email subscriptions@bsigroup.com.

Revisions

Our British Standards and other publications are updated by amendment or revision.

We continually improve the quality of our products and services to benefit your business. If you find an inaccuracy or ambiguity within a British Standard or other BSI publication please inform the Knowledge Centre.

Useful Contacts

Customer Services

Tel: +44 345 086 9001

Email (orders): orders@bsigroup.com

Email (enquiries): cservices@bsigroup.com

Subscriptions

Tel: +44 345 086 9001

Email: subscriptions@bsigroup.com

Knowledge Centre

Tel: +44 20 8996 7004

Email: knowledgecentre@bsigroup.com

Copyright & Licensing

Tel: +44 20 8996 7070

Email: copyright@bsigroup.com

BSI Group Headquarters

389 Chiswick High Road London W4 4AL UK