

BS ISO 14085-5:2015



BSI Standards Publication

# Aerospace series — Hydraulic filter elements — Test methods

Part 5: Resistance to flow fatigue

**bsi.**

...making excellence a habit.™

**National foreword**

This British Standard is the UK implementation of ISO 14085-5:2015.

The UK participation in its preparation was entrusted to Technical Committee ACE/69, Aerospace hydraulic systems, fluids and components.

A list of organizations represented on this committee can be obtained on request to its secretary.

This publication does not purport to include all the necessary provisions of a contract. Users are responsible for its correct application.

© The British Standards Institution 2015.

Published by BSI Standards Limited 2015

ISBN 978 0 580 80581 3

ICS 49.080

**Compliance with a British Standard cannot confer immunity from legal obligations.**

This British Standard was published under the authority of the Standards Policy and Strategy Committee on 31 March 2015.

**Amendments issued since publication**

Date	Text affected
------	---------------

---

---

---

**Aerospace series — Hydraulic filter  
elements — Test methods —**

**Part 5:  
Resistance to flow fatigue**

*Série aérospatiale — Éléments filtrants hydrauliques — Méthode  
d'essais —*

*Partie 5: Résistance aux variations cycliques de débit*





**COPYRIGHT PROTECTED DOCUMENT**

© ISO 2015

All rights reserved. Unless otherwise specified, no part of this publication may be reproduced or utilized otherwise in any form or by any means, electronic or mechanical, including photocopying, or posting on the internet or an intranet, without prior written permission. Permission can be requested from either ISO at the address below or ISO's member body in the country of the requester.

ISO copyright office  
Case postale 56 • CH-1211 Geneva 20  
Tel. + 41 22 749 01 11  
Fax + 41 22 749 09 47  
E-mail [copyright@iso.org](mailto:copyright@iso.org)  
Web [www.iso.org](http://www.iso.org)

Published in Switzerland

# Contents

	Page
Foreword .....	iv
Introduction .....	v
<b>1 Scope .....</b>	<b>1</b>
<b>2 Normative references .....</b>	<b>1</b>
<b>3 Terms and definitions .....</b>	<b>1</b>
<b>4 Graphic symbols and circuit diagrams .....</b>	<b>2</b>
<b>5 Test equipment and supplies .....</b>	<b>2</b>
<b>6 Accuracy of measurements and test conditions .....</b>	<b>4</b>
<b>7 Test procedure .....</b>	<b>4</b>
<b>8 Acceptance criteria .....</b>	<b>6</b>
<b>9 Data presentation .....</b>	<b>6</b>
<b>10 Identification statement .....</b>	<b>6</b>
<b>Annex A (informative) Flow fatigue test data report form .....</b>	<b>7</b>

## Foreword

ISO (the International Organization for Standardization) is a worldwide federation of national standards bodies (ISO member bodies). The work of preparing International Standards is normally carried out through ISO technical committees. Each member body interested in a subject for which a technical committee has been established has the right to be represented on that committee. International organizations, governmental and non-governmental, in liaison with ISO, also take part in the work. ISO collaborates closely with the International Electrotechnical Commission (IEC) on all matters of electrotechnical standardization.

The procedures used to develop this document and those intended for its further maintenance are described in the ISO/IEC Directives, Part 1. In particular the different approval criteria needed for the different types of ISO documents should be noted. This document was drafted in accordance with the editorial rules of the ISO/IEC Directives, Part 2 (see [www.iso.org/directives](http://www.iso.org/directives)).

Attention is drawn to the possibility that some of the elements of this document may be the subject of patent rights. ISO shall not be held responsible for identifying any or all such patent rights. Details of any patent rights identified during the development of the document will be in the Introduction and/or on the ISO list of patent declarations received (see [www.iso.org/patents](http://www.iso.org/patents)).

Any trade name used in this document is information given for the convenience of users and does not constitute an endorsement.

For an explanation on the meaning of ISO specific terms and expressions related to conformity assessment, as well as information about ISO's adherence to the WTO principles in the Technical Barriers to Trade (TBT) see the following URL: [Foreword - Supplementary information](#)

The committee responsible for this document is ISO/TC 20, *Aircraft and space vehicles*, Subcommittee SC 10, *Aerospace fluid systems and components*.

ISO 14085 consists of the following parts, under the general title *Aerospace series — Hydraulic Filter elements — Test methods*:

- *Part 1: Test sequence*
- *Part 2: Conditioning*
- *Part 3: Filtration efficiency and retention capacity*
- *Part 4: Verification of collapse/burst pressure rating*
- *Part 5: Resistance to flow fatigue*
- *Part 6: Cleanliness Level*

## Introduction

In aerospace hydraulic fluid power systems, power is transmitted and controlled through a liquid under pressure. The liquid is both a lubricant and power-transmitting medium. The presence of solid contaminant particles in the liquid interferes with the ability of the hydraulic fluid to lubricate and causes wear and malfunction of the components. The extent of contamination in the fluid has a direct bearing in the performance, reliability, and safety of the system, and needs to be controlled to levels that are considered appropriate for the system concerned.

Different principles are used to control the contamination level of the fluid by removing solid contaminant particles; one of them uses a filter element enclosed in a filter housing. The filter element is the porous device that performs the actual process of filtration. The complete assembly is designated as a filter.

The effectiveness of the filter element in controlling contaminants is dependent on its design and its sensitivity to any dynamic operating conditions that may stress the filter element and cause damage to it, especially as it becomes clogged and the differential pressure rises.

This part of ISO 14085 provides a procedure to determine the ability of a filter element, under increasing differential pressures, to withstand dynamic operating conditions by evaluating its remaining integrity and performance after being subjected to cyclic flow variations.





# Aerospace series — Hydraulic filter elements — Test methods —

## Part 5: Resistance to flow fatigue

### 1 Scope

This part of ISO 14085 specifies a method for determining the resistance of a filter element to flow fatigue caused by varying flow through the filter in various stages of the filter contaminant loading process. The filter is subjected to a uniform varying flow rate for a specified number of cycles, at a number of predetermined differential pressures.

Although the number of cycles and differential pressure conditions used in this part of ISO 14085 is meant to simulate possible service conditions, this part of ISO 14085 is not intended to qualify a filter element under replicate conditions of service; this can only be done by a specific test protocol developed for the purpose, including actual conditions of use, for example the operating fluid, contamination, and exact cyclic flow conditions.

This part of ISO 14085 establishes a method for verifying the ability of a filter element to withstand the stress caused by cyclic differential pressures induced by a variable flow rate.

The test data resulting from application of this part of ISO 14085 can be used to compare the performance of aerospace hydraulic filter elements.

### 2 Normative references

The following documents, in whole or in part, are normatively referenced in this document and are indispensable for its application. For dated references, only the edition cited applies. For undated references, the latest edition of the referenced document (including any amendments) applies

ISO 1219-1, *Fluid power systems and components — Graphic symbols and circuit diagrams — Part 1: Graphic symbols for conventional use and data-processing applications*

ISO 2942, *Hydraulic fluid power — Filter elements — Verification of fabrication integrity and determination of the first bubble point*

ISO 2943, *Hydraulic fluid power — Filter elements — Verification of material compatibility with fluids*

ISO 5598, *Fluid power systems and components — Vocabulary*

ISO 12103-1, *Road vehicles — Test dust for filter evaluation — Part 1: Arizona test dust*

ISO 14085-3, *Aerospace series — Hydraulic filter elements - Test methods — Part 3: Filtration efficiency and retention capacity*

### 3 Terms and definitions

For the purposes of this document, the terms and definitions given in ISO 5598 and the following apply.

**3.1 clean assembly differential pressure**  
difference between the tested component inlet and outlet pressure as measured with a clean filter housing containing a clean filter element

**3.2 clean element differential pressure**  
differential pressure of the clean element at rated flow, calculated as the difference between the *clean assembly differential pressure* (3.1) and the housing differential pressure

**3.3 differential pressure**  
 $\Delta p$   
difference between the inlet and outlet pressures of the component under test, as measured under specified conditions

**3.4 filter element resistance to flow fatigue**  
ability of a filter element to resist structural failure or performance degradation due to flexing caused by cyclic system flow rate conditions

**3.5 housing differential pressure**  
*differential pressure* (3.3) of the filter housing without an element

**3.6 rated flow rate**  
maximum design flow rate for the filter element as specified by the manufacturer

**3.7 terminal element differential pressure**  
maximum *differential pressure* (3.3) across the filter element as designated by the manufacturer to limit useful performance

## 4 Graphic symbols and circuit diagrams

Graphic symbols are used in accordance with ISO 1219-1.

## 5 Test equipment and supplies

**5.1 Pressure-sensing and recording instruments**, shall have a frequency response sufficient to measure the full pressure-versus-time curve (see [Figure 1](#)).

**5.2 Flow fatigue cycle test stand**, shall be capable of varying the test flow rate between 0 l/min up to the rated or maximum test flow rate, within the requirements of [Figure 1](#). Use a test stand similar to that depicted in [Figure 2](#).

**5.3 Test filter housing**, shall be used as recommended by the filter manufacturer and modified as needed to ensure that fluid cannot by-pass the filter element.

**5.4 Test fluid**, shall be compatible with the filter element materials of construction. If necessary, the compatibility of the fluid and filter element materials of construction can be verified in accordance with ISO 2943.

NOTE A fluid viscosity between 14 mm<sup>2</sup>/s and 32 mm<sup>2</sup>/s at the test temperature is recommended; unless otherwise agreed between the parties involved.

5.5 **Cycle counting device**, capable of recording the number of flow fatigue cycles.

5.6 **Test contaminant**: Use ISO Fine Test Dust (ISO FTD), grade A2 in accordance with ISO 12103-1.

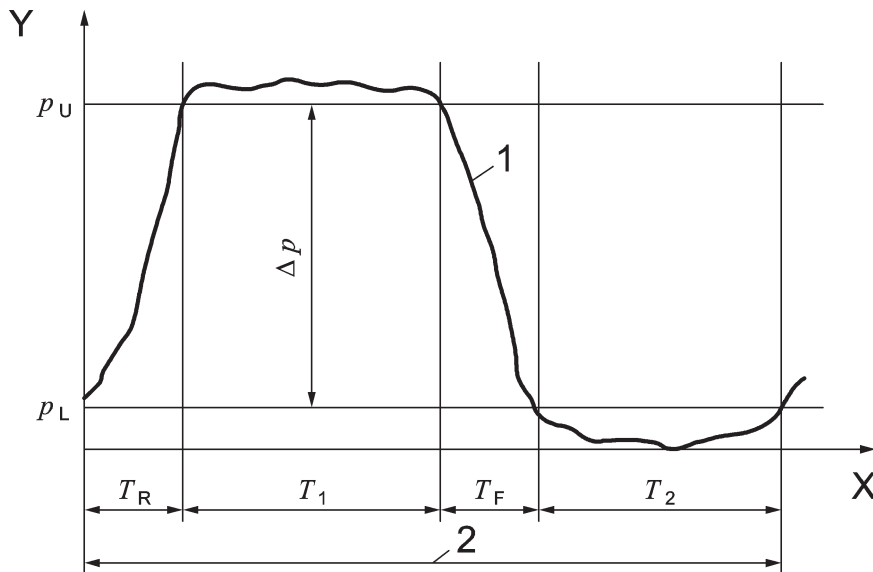

**Key**

- 1 actual test pressure (kPa)
- 2 one cycle test time (s):  $T$
- X time (s)
- Y pressure (kPa)
- $p_L$  lower test pressure:  $p_L \leq 10 \% p_u$
- $p_u$  upper test pressure: tolerance on  $p_u$  is  $-0 \%/+10 \%$
- $T_R$  rise time:  $T_R = (15 \% \pm 5 \%)T$
- $T_1$  time at pressure:  $T_1 = (35 \% \pm 5 \%)T$
- $T_F$  fall time:  $T_F = (15 \% \pm 5 \%)T$
- $T_2$  time at lowest test pressure:  $T_2 = (35 \% \pm 5 \%)T$

**Figure 1 — Flow fatigue cycle waveform**

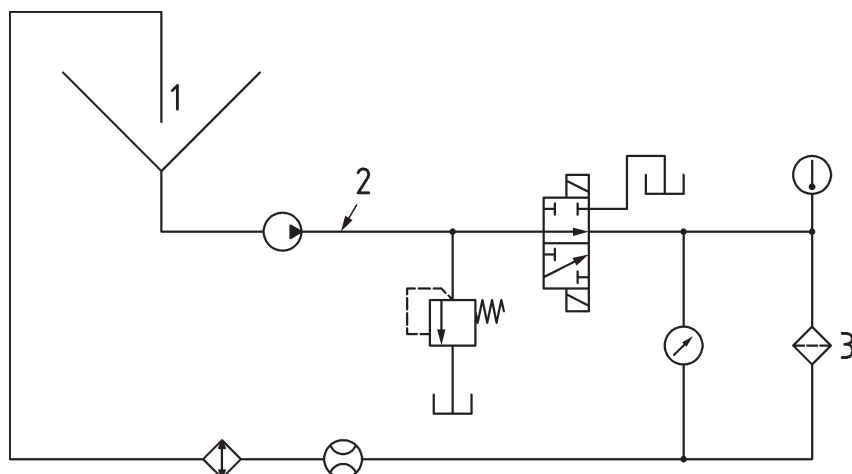

**Key**

- 1 contaminant injection in reservoir
- 2 alternate point for contaminant injection
- 3 test filter

**Figure 2 — Typical filter element flow fatigue cycle test stand circuit**

NOTE The circuit in this figure is simplified and includes only the basic components for conducting the test specified in this part of ISO 14085. Other components or additional circuitry (e.g. a clean-up filter loop) might be necessary. In all cases, connection lines to test filter should be as short as possible, and piping should be rigid to limit initial pressure peak and prevent pressure overshoot

**6 Accuracy of measurements and test conditions**

Instruments used to measure test parameters shall provide the reading accuracy specified in [Table 1](#). Test conditions shall be maintained within the tolerances specified in [Table 1](#).

**Table 1 — Instrument accuracy and test condition variation**

Test parameter	Unit	Measurement accuracy	Allowable test condition variations
Flow rate	l/min	±2 %	±10 %
Differential pressure	kPa	±2 %	-0 %/+10 %
Temperature	°C	±1 °C	±3 °C
Cycle rate	Hz	—	±10 %

**7 Test procedure**

- 7.1 Subject the filter element under test to a fabrication integrity test in accordance with ISO 2942.
- 7.2 Disqualify from further testing any element that fails to pass the criteria specified in ISO 2942.
- 7.3 Install the test filter housing in the flow fatigue cycle test stand (see [5.2](#) and [Figure 2](#)).
- 7.4 Plot the housing differential pressure versus flow rate. Determine the test filter housing differential pressure from at least 25 % up to 100 % of the maximum test flow rate at the test temperature selected. Record the results into column 3 of [Table 3](#).

7.5 Install the filter element in the test filter housing.

7.6 Calculate and plot the final assembly differential pressure curve corresponding to the predetermined terminal element differential pressure plus the housing differential pressure at the same flow rates as used in 7.4. Record the results on the report sheet into Column 4 of Table 3.

7.7 Calculate the clean element differential pressure at maximum flow, then determine the element differential pressures and number of cycles required for testing. Use the conditions given in Table 2, unless otherwise specified. Enter the values into columns 2 and 5 of Table 3.

**Table 2 — Specified flow fatigue duty cycle**

Test condition	Element differential pressure	Number of flow fatigue cycles
1	2 × clean element $\Delta p$ at max flow	90 000
2	4 × clean element $\Delta p$ at max flow	8 000
3	Terminal element $\Delta p$	2 000
4	System pressure (for non-by-pass type filters) or maximum full-flow by-pass $\Delta p$ (for by-pass type filters)	500

7.8 Complete columns 2, 3, and 5 in Table 3 using the information from 7.4, 7.6, and 7.7. Calculate the assembly differential pressures required for the flow cycling by completing column 4 in Table 3.

**Table 3 — Test flow fatigue duty cycle**

Test condition	Element $\Delta p$ calculated from Table 2, column 2	Housing $\Delta p$ at maximum test flow	Assembly $\Delta p$ for fatigue testing (column 2 plus column 3)	Number of flow fatigue cycles from Table 2, column 3
1				
2				
3				
4				

7.9 Set the system flow rate to the maximum test flow rate, then add test contaminant until the assembly differential pressure for test condition 1 (from Table 3) is reached.

NOTE If it is advantageous to start flow cycling while loading the filter element to the designated assembly differential pressure, ensure that the cycle counting device is reset to zero before proceeding to 7.10.

7.10 Carry out the flow fatigue cycle test for test condition 1. Each flow fatigue cycle shall consist of varying the flow rate through the filter element from 0 l/min to a flow rate between 25 % and 100 % of the maximum test flow rate and then back to 0 l/min, while maintaining the required assembly differential pressure and differential-pressure-versus-time trace specified in Figure 1. The frequency of the test cycle rate shall be selected from the range between 0,2 Hz to 1 Hz (inclusive) and shall remain constant within the tolerance given in Table 1 throughout the test.

NOTE 1 The filter element might need more contaminant to maintain the designated assembly differential pressure at lower flow rates such as 25 % of the rated flow rate. However, because the filter element can experience particle desorption due to the variation in flow rate, it is suggested that initial contaminant be injected at the minimum or intermediate flow rate (i.e. 25 % or other percentage of rated flow rate) until the designated assembly differential pressure is reached. This approach can minimize the total amount of contaminant used during the duration of the test, as the differential pressure can be maintained by increasing the flow rate instead of adding more contaminant.

Initially, contaminant should be added in a uniform manner. For incremental injections, a mass of 5 % of the estimated filter element contaminant capacity per addition is recommended. Adjustments to the quantities of contaminant added and time intervals between injections can be required.

NOTE 2 The test can be interrupted and restarted as necessary. If the test is interrupted, additions of contaminant are typically required to regain the designated assembly differential pressure.

**7.11** Monitor and control the assembly differential pressure by reducing or increasing the flow rate as needed between 25 % and 100 % of the maximum test flow rate.

NOTE A relief valve can be used (see [Figure 2](#)) and adjusted as necessary to limit peak differential pressure to the final assembly differential pressure within a tolerance of  $\pm 10$  %, as specified in the waveform in [Figure 1](#). Contaminant can also be added periodically during the test to maintain differential pressure.

**7.12** Subject the filter element to the required number of flow fatigue cycles.

**7.13** Obtain and present a typical differential-pressure-versus-time trace for at least one cycle (see [Figure 1](#)) during the first and last 100 cycles. Record on the report sheet in [Annex A](#) the differential pressures, contaminant additions, and number of cycles completed.

**7.14** Repeat [7.9](#) through [7.13](#) for test conditions 2, 3, and 4 or until all required test conditions have been completed.

**7.15** Rinse element carefully with a solvent to remove as much captured contaminant as possible. Include a gentle rinse from the downstream side towards the upstream side.

**7.16** Conduct a visual examination of the element and report observations on the report sheet in [Annex A](#).

**7.17** If no visual damage is seen, subject the filter element to an abbreviated steady flow multi-pass test in accordance with ISO 14085-3. Use a test flow equal to 20 % of the maximum flow fatigue flow rate and conduct the efficiency test for a total of 10 min or until terminal element differential pressure is attained.

The element can remain significantly clogged although rinsed, and this can limit the duration for which the multi-pass test is conducted. At least one data set should be recorded from the multi-pass test to achieve one set of filtration rating data.

## 8 Acceptance criteria

The filter element shall be considered accepted if after completion of the required number of flow fatigue cycles it passes the visual examination, and the results of the abbreviated multi-pass test meet the required criteria.

## 9 Data presentation

As a minimum, all of the test data and calculation results called for in [Annex A](#) shall be presented. An example of the report sheet is given in [Annex A](#).

## 10 Identification statement

Use the following statement in test reports, catalogues, and sales literature when electing to comply with this part of ISO 14085.

“Method for testing filter elements in accordance with ISO 14085-5, *Aerospace series — Hydraulic Filter elements - Test methods — Part 5: Resistance to flow fatigue.*”

## Annex A (informative)

### Flow fatigue test data report form

Test laboratory: ..... Test date: ..... Operator: .....

**Filter and element identification**

Element identification number: ..... Housing identification number: .....

Spin-on: Yes: ..... No: ..... Minimum element bubble point: ..... Pa

**Operating conditions**

Test fluid: Type: ..... Ref.: ..... Batch no.: .....

Viscosity at the test temperature: ..... mm<sup>2</sup>/s Temperature: ..... °C

Test contaminant: Type: ..... Batch no.: .....

Test parameters: Maximum test flow rate: ..... l/min Terminal element  $\Delta p$ : ..... kPa

**Test results:**

Element integrity: Bubble point per ISO 2942: ..... Pa Pass..... Fail ..... BP test fluid:.....

Differential pressures, measured at maximum test flow rate:

Housing  $\Delta p$ : ..... kPa Clean assembly  $\Delta p$ : ..... kPa Clean element  $\Delta p$ : ..... kPa

Test condition	Element $\Delta p$ , kPa used for fatigue testing	Assembly $\Delta p$ , kPa, used for fatigue testing	Number of flow fatigue cycles completed	Flow rate used for testing, L/min
1				
2				
3				
4				
other				

Test waveforms: (include a recorded differential-pressure-versus-time trace for each test condition, conforming to [Figure 1](#))

Total number of cycles completed: ..... Cycle rate: .....

Results of visual examination: .....

.....

Results of abbreviated efficiency test: .....

.....

.....







# British Standards Institution (BSI)

BSI is the national body responsible for preparing British Standards and other standards-related publications, information and services.

BSI is incorporated by Royal Charter. British Standards and other standardization products are published by BSI Standards Limited.

## About us

We bring together business, industry, government, consumers, innovators and others to shape their combined experience and expertise into standards-based solutions.

The knowledge embodied in our standards has been carefully assembled in a dependable format and refined through our open consultation process. Organizations of all sizes and across all sectors choose standards to help them achieve their goals.

## Information on standards

We can provide you with the knowledge that your organization needs to succeed. Find out more about British Standards by visiting our website at [bsigroup.com/standards](http://bsigroup.com/standards) or contacting our Customer Services team or Knowledge Centre.

## Buying standards

You can buy and download PDF versions of BSI publications, including British and adopted European and international standards, through our website at [bsigroup.com/shop](http://bsigroup.com/shop), where hard copies can also be purchased.

If you need international and foreign standards from other Standards Development Organizations, hard copies can be ordered from our Customer Services team.

## Subscriptions

Our range of subscription services are designed to make using standards easier for you. For further information on our subscription products go to [bsigroup.com/subscriptions](http://bsigroup.com/subscriptions).

With **British Standards Online (BSOL)** you'll have instant access to over 55,000 British and adopted European and international standards from your desktop. It's available 24/7 and is refreshed daily so you'll always be up to date.

You can keep in touch with standards developments and receive substantial discounts on the purchase price of standards, both in single copy and subscription format, by becoming a **BSI Subscribing Member**.

**PLUS** is an updating service exclusive to BSI Subscribing Members. You will automatically receive the latest hard copy of your standards when they're revised or replaced.

To find out more about becoming a BSI Subscribing Member and the benefits of membership, please visit [bsigroup.com/shop](http://bsigroup.com/shop).

With a **Multi-User Network Licence (MUNL)** you are able to host standards publications on your intranet. Licences can cover as few or as many users as you wish. With updates supplied as soon as they're available, you can be sure your documentation is current. For further information, email [bsmusales@bsigroup.com](mailto:bsmusales@bsigroup.com).

## BSI Group Headquarters

389 Chiswick High Road London W4 4AL UK

## Revisions

Our British Standards and other publications are updated by amendment or revision.

We continually improve the quality of our products and services to benefit your business. If you find an inaccuracy or ambiguity within a British Standard or other BSI publication please inform the Knowledge Centre.

## Copyright

All the data, software and documentation set out in all British Standards and other BSI publications are the property of and copyrighted by BSI, or some person or entity that owns copyright in the information used (such as the international standardization bodies) and has formally licensed such information to BSI for commercial publication and use. Except as permitted under the Copyright, Designs and Patents Act 1988 no extract may be reproduced, stored in a retrieval system or transmitted in any form or by any means – electronic, photocopying, recording or otherwise – without prior written permission from BSI. Details and advice can be obtained from the Copyright & Licensing Department.

## Useful Contacts:

### Customer Services

**Tel:** +44 845 086 9001

**Email (orders):** [orders@bsigroup.com](mailto:orders@bsigroup.com)

**Email (enquiries):** [cservices@bsigroup.com](mailto:cservices@bsigroup.com)

### Subscriptions

**Tel:** +44 845 086 9001

**Email:** [subscriptions@bsigroup.com](mailto:subscriptions@bsigroup.com)

### Knowledge Centre

**Tel:** +44 20 8996 7004

**Email:** [knowledgecentre@bsigroup.com](mailto:knowledgecentre@bsigroup.com)

### Copyright & Licensing

**Tel:** +44 20 8996 7070

**Email:** [copyright@bsigroup.com](mailto:copyright@bsigroup.com)



...making excellence a habit.™